

ISOLATED DC/DC CONVERTERS

24 Vdc Input 12 Vdc /20 A Output



Sep. 11, 2010

Bel Power Inc., a subsidiary of Bel Fuse Inc.

0RQB-T0R12x

RoHS Compliant

Rev.D

Features

- Isolated
- Fixed Frequency (307 kHz)
- High Efficiency
- High Power Density
- Input Under Voltage Lockout
- Input Over Voltage Lockout
- Low Cost
- Class 1, Category 2, Isolated DC/DC Converter (refer to IPC-9592)
- UL60950-1 Recognized (UL/cUL) (Pending)
- Output Over Voltage Shutdown
- Over Temperature Protection
- SCP/OCP
- Remote On/Off
- Basic Isolation
- Baseplate



Applications

- Networking
- Computers and peripherals
- Telecommunications

Description

The 0RQB-T0R12x is isolated dc/dc converter that operates from a nominal 24 Vdc source. This unit will provide up to 240 W output power from a nominal 24 Vdc input. These units are designed to be highly efficient and low cost. Features include remote on/off, over current protection and under-voltage lockout. This converter is provided in an industry standard quarter brick package.

Part Selection

Output Voltage	Input Voltage	Max. Output Current	Max. Output Power	Typical Efficiency	Model Number Active High	Model Number Active Low
12 Vdc	18 Vdc - 36 Vdc	20 A	240 W	94.5%	0RQB-T0R120	0RQB-T0R12L

Notes: Add "G" suffix at the end of the model number to indicate Tray Packaging.

Part Number Explanation

0 R QB - T0 R 12 x
1 2 3 4 5 6 7

- 1---Through hole
- 2---RoHS 6, change "R" to "7" means RoHS 5
- 3---Series name, 1/4 Brick
- 4---Series code
- 5---Input range 24V wide (18-36V)
- 6---Output voltage (12V)
- 7---Suffix

ISOLATED DC/DC CONVERTERS

24 Vdc Input 12 Vdc /20 A Output



Sep. 11, 2010

Bel Power Inc., a subsidiary of Bel Fuse Inc.

Absolute Maximum Ratings

Parameter	Min	Typ	Max	Unit	Notes
Continuous Input Voltage	-0.3	-	40	V	non-operating
Input Transient Voltage	-	-	50	V	100 mS maximum
Remote On/Off	-0.3	-	18	V	
I/O Isolation Voltage	-	-	1500	V	
Ambient Temperature	-40	-	85	°C	
Storage Temperature	-55	-	125	°C	

Note: Ratings used beyond the maximum ratings may cause a reliability degradation of the converter or may permanently damage the device.

Input Specifications

Parameter	Min	Typ	Max	Unit	Notes
Operating Input Voltage	18	24	36	V	
Input Current (full load)	-	-	15.0	A	
Input Current (no load)	-	180	200	mA	
Remote Off Input Current	-	5	10	mA	
Input Reflected Ripple Current (rms)	-	5	8	mA	Tested with simulated source impedance of 10 uH, 5 Hz to 20 MHz; use a 100 uF/100 V electrolytic capacitor with ESR = 1 ohm max. at 200 kHz at 25 °C.
Input Reflected Ripple Current (pk-pk)	-	15	25	mA	
I ² t Inrush Current Transient	-	0.05	0.1	A ² s	
Turn-on Voltage Threshold	16.0	16.8	17.5	V	
Turn-off Voltage Threshold	15.5	16.5	17.0	V	

CAUTION: This converter is not internally fused. An input line fuse must be used in application.

Recommend a fast-acting fuse with maximum rating of 25A on system board. Refer to the fuse manufacture's datasheet for further information.

- Notes:**
1. This converter has internal C-L-C (23.5uF) filter.
 2. All specifications are typical at 25 °C unless otherwise stated.

Output Specifications

Parameter	Min	Typ	Max	Unit	Notes
Output Voltage Set Point	11.76	12	12.24	V	Vin=24V, Io=50% load
Load Regulation	-	±20	±30	mV	
Line Regulation	-	±10	±15	mV	
Regulation Over Temperature (-40deg.C-85deg.C)	-	±100	±200	mV	
Ripple and Noise (pk-pk)	-	100	120	mV	Vin=24V, full load, 0-20MHz BW, with a 1µF ceramic capacitor and a 10uF Tantalum cap at output.
Ripple and Noise (rms)	-	25	40	mV	
Ripple and Noise (pk-pk) under worst case	-	-	150	mV	over all operating input voltage, load and temperature conditions.

ISOLATED DC/DC CONVERTERS

24 Vdc Input 12 Vdc /20 A Output



Sep. 11, 2010

Bel Power Inc., a subsidiary of Bel Fuse Inc.

Output Specifications (continued)

Parameter	Min	Typ	Max	Unit	Notes	
Output Current Range	0	-	20	A		
Output DC Current Limit	22	26	30	A		
Short Circuit Surge Transient	-	-	5	A ² s		
Rise time	8	-	12	ms		
Turn on Time		25	35	mS	Enable form Vin	
	-	25	35	mS	Enable form ON/OFF	
Overshoot at Turn on	-	0	3	%		
Output Capacitance	0	-	5000	uF		
Transient Response						
ΔV50%~75% of Max Load	Overshoot	-	300	400	mV	di/dt=0.1A/us, Vin=24Vdc, Ta=25°C, with a 1μF ceramic capacitor and a 10uF Tantalum cap at the output.
	Settling Time	-	120	200	uS	
ΔV75%~50% of Max Load	Overshoot	-	300	400	mV	
	Settling Time	-	120	200	uS	

Note: All specifications are typical at nominal input, full load at 25°C unless otherwise stated.

General Specifications

Parameter	Min	Typ	Max	Unit	Notes
Efficiency	94	94.5	-	%	Vin=24V, full load
Switching Frequency	-	307	-	kHz	
Over Temperature Protection	-	125	130	°C	
Over Voltage Protection(Static)	-	14.15	14.5	V	This voltage is achieved by trimming up output slowly
Weight	-	75	-	g	
FIT		362.8		-	Calculated Per Bell Core SR-332 (Vin=24 V, Vo=12 V, Io=7 A, Ta = 25° C, FIT=109/MTBF)
Dimensions					
Inches (L x W x H)		2.30 x 1.45 x 0.50		-	
Millimeters (L x W x H)		58.42 x 36.83 x 12.70			
Isolation characteristics					
Input to Output	-	-	1500	V	
Input to Case	-	-	1500	V	
Output to Case	-	-	500	V	
Isolation Resistance	10M	-		ohm	
Isolation Capacitance	-	3900	-	pF	

Note: All specifications are typical at 25 °C unless otherwise stated.

ISOLATED DC/DC CONVERTERS

24 Vdc Input 12 Vdc /20 A Output



Sep. 11, 2010

Bel Power Inc., a subsidiary of Bel Fuse Inc.

Thermal Derating Curve

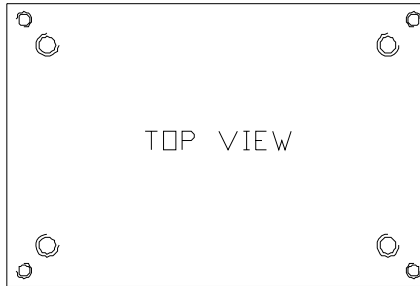

Forced Airflow Direction

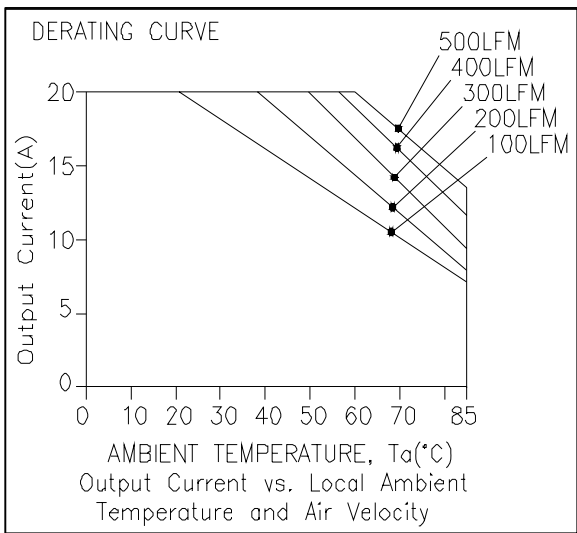

Derating curve under normal input

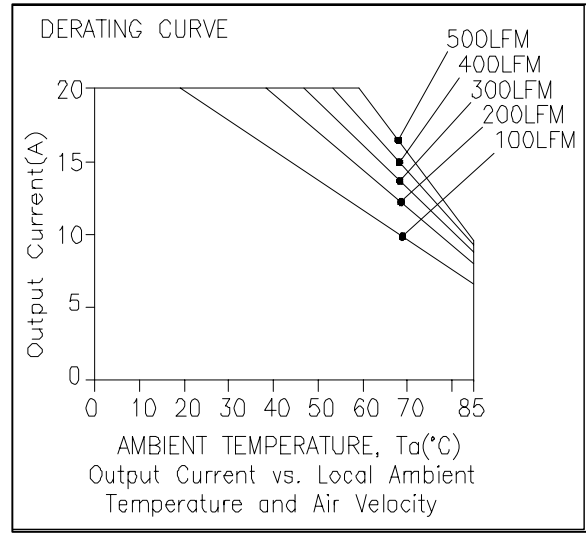

Derating curve under worst case input

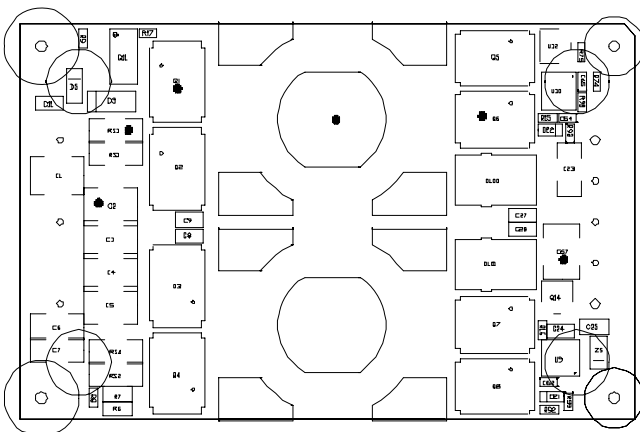

TOP VIEW

Temperature reference points on top side

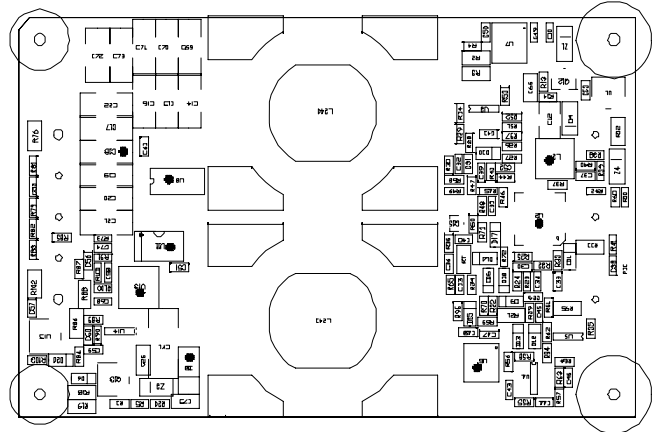

BOTTOM VIEW

Temperature reference points on bottom side

ISOLATED DC/DC CONVERTERS

24 Vdc Input 12 Vdc /20 A Output



Sep. 11, 2010

Bel Power Inc., a subsidiary of Bel Fuse Inc.

Ripple and Noise Waveform

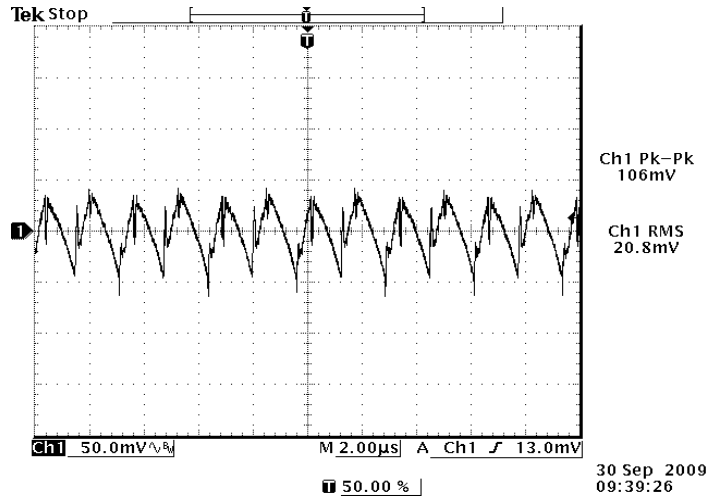

24Vdc input, 12Vdc/20A

Note: Ripple and noise at full load, and with a 1uF ceramic cap and a 10 uF Tantalum cap at output and Ta=25 deg C.

Transient Response Waveforms

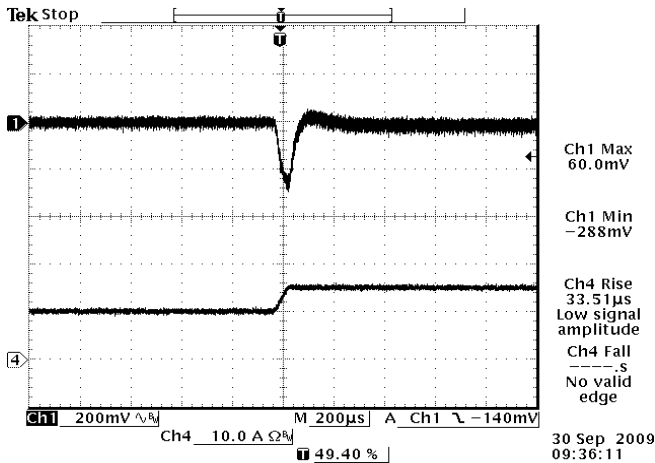

Vout= 12V 50%-75% Load Transients

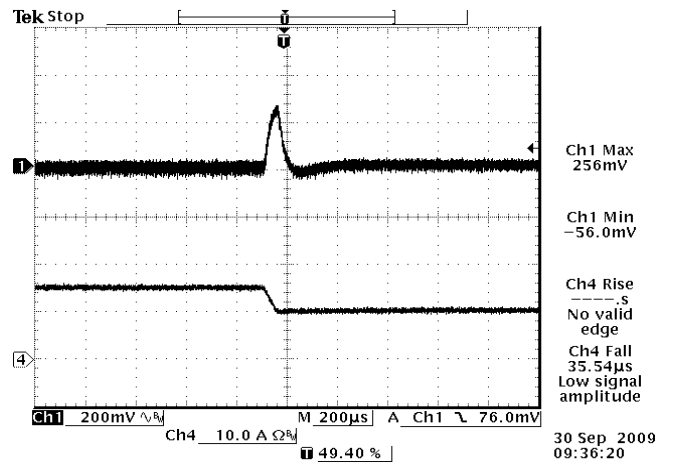

Vout= 12V 75%-50% Load Transients

Note: Transient Response at di/dt=0.1A/uS, Vin=24V, with 1uF ceramic cap and 10uF aluminum cap at output and Ta=25 deg C.

ISOLATED DC/DC CONVERTERS

24 Vdc Input 12 Vdc /20 A Output



Sep. 11, 2010

Bel Power Inc., a subsidiary of Bel Fuse Inc.

Startup & Shutdown

Rise time

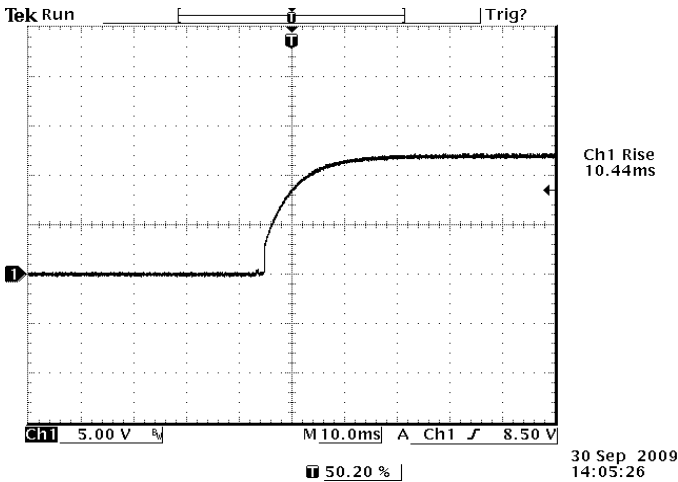

Vin = 24 V, Full Load

Startup time

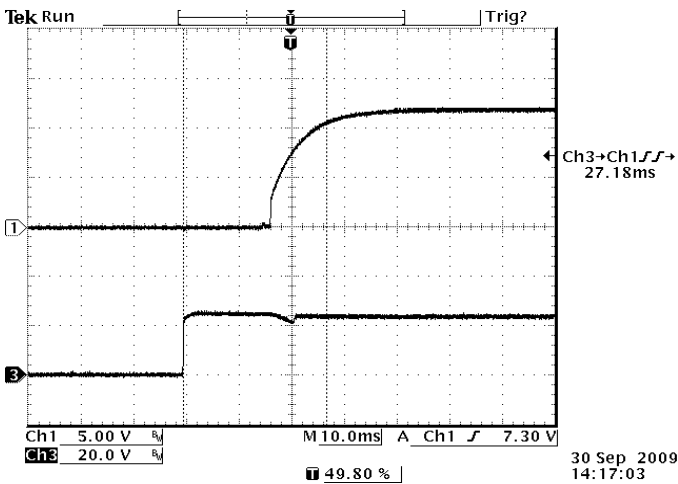

Startup from Vin
Ch1: Vo
Ch3: Vin
Vin = 24 V, Full Load

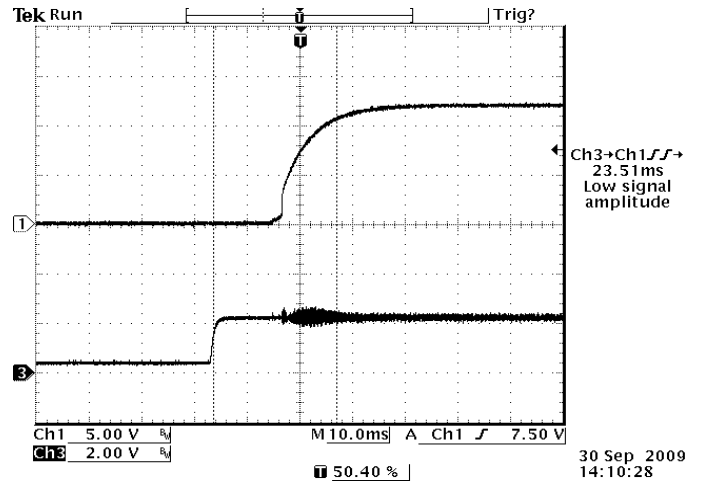

Startup from on/off
Ch1: Vo
Ch3: on/off
Vin = 24 V, Full Load

ISOLATED DC/DC CONVERTERS

24 Vdc Input 12 Vdc /20 A Output



Sep. 11, 2010

Bel Power Inc., a subsidiary of Bel Fuse Inc.

Startup & Shutdown (continued)

Shutdown

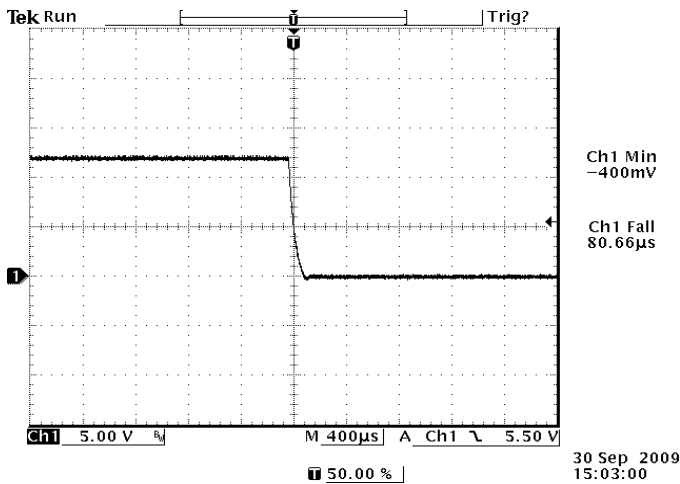

Vin = 24 V, Full Load

Efficiency Data

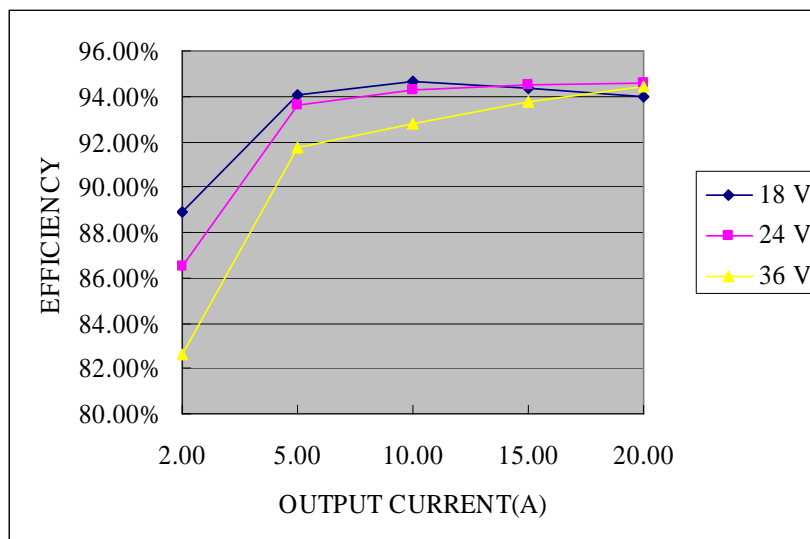

ISOLATED DC/DC CONVERTERS

24 Vdc Input 12 Vdc /20 A Output



Sep. 11, 2010

Bel Power Inc., a subsidiary of Bel Fuse Inc.

Remote On/Off

Parameter		Min	Typ	Max	Unit	Notes
Signal Low (Unit On)	Active Low	-0.3	-	0.8	V	0RQB-T0R12L. The remote on/off pin open, Unit off.
Signal High (Unit Off)		2.4	-	18	V	
Signal Low (Unit Off)	Active High	-0.3	-	0.8	V	0RQB-T0R120. The remote on/off pin open, Unit on.
Signal High (Unit On)		2.4	-	18	V	
Current Sink		0	-	1	mA	

Recommended remote on/off circuit for active low

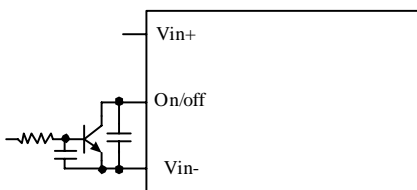

Control with open collector/drain circuit

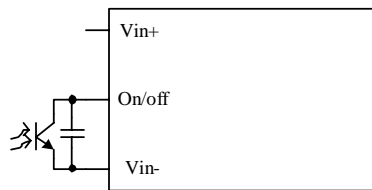

Control with photocoupler circuit

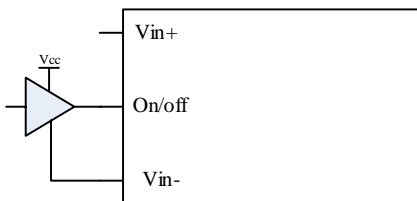

Control with logic circuit

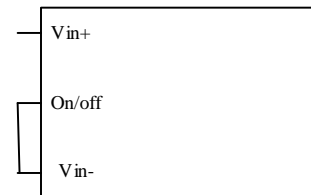

Permanently on

Recommended remote on/off circuit for active high

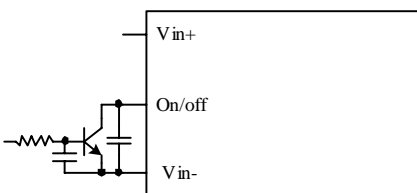

Control with open collector/drain circuit

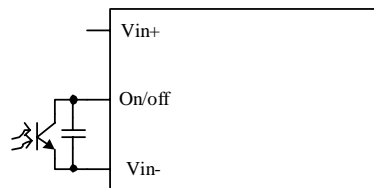

Control with photocoupler circuit

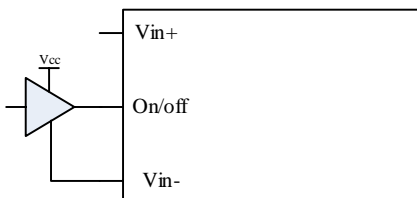

Control with logic circuit

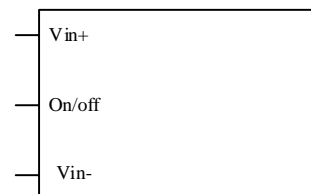

Permanently on

ISOLATED DC/DC CONVERTERS

24 Vdc Input 12 Vdc /20 A Output



Sep. 11, 2010

Bel Power Inc., a subsidiary of Bel Fuse Inc.

Output Trim Equations

Equations for calculating the trim resistor are shown below. The Trim Down resistor should be connected between the Trim pin and Sense (-) pin. The Trim Up resistor should be connected between the Trim pin and the Sense (+). Only one of the resistors should be used for any given application.

Minimum trim down voltage is 10.8V

Maximum trim up voltage is 13.2V.

The total voltage increased by trim and remote sense should not exceed 10% of the nominal output voltage.

$$R_{trimdown} = \frac{511}{|\delta|} - 10.22 [k\Omega]$$

$$R_{trimup} = \frac{(100 + \delta) \cdot V_o \cdot 5.11 - 626}{1.225 \cdot \delta} - 10.22 [k\Omega]$$

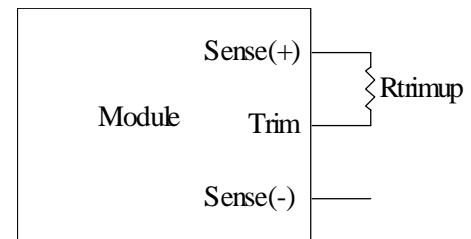
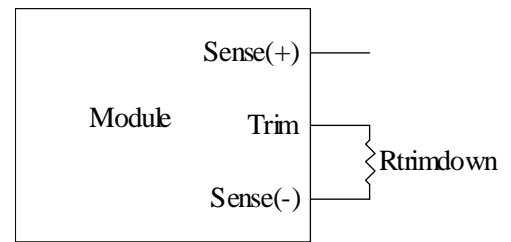

Note:

$$\delta = \frac{(V_o_{req} - V_o)}{V_o} \times 100 [\%]$$

V_o_{req} = Desired (trimmed) output voltage [V]

Output voltage V_o = 12.036V

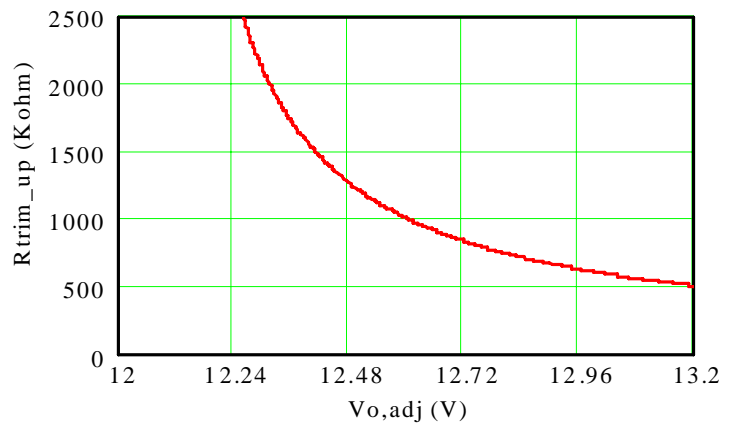
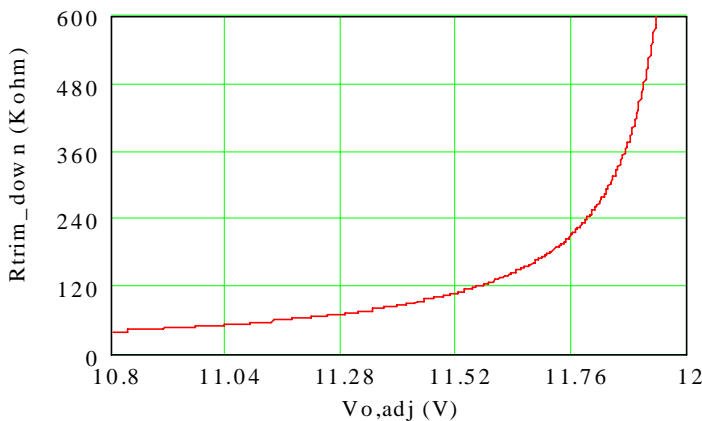

ISOLATED DC/DC CONVERTERS

24 Vdc Input 12 Vdc /20 A Output



Sep. 11, 2010

Bel Power Inc., a subsidiary of Bel Fuse Inc.

Remote Sense

This module has remote sense compensation feature. It can minimize the effects of resistance between module's output and load in system layout and facilitates accurate voltage regulation at load terminals or other selected point.

1. The remote sense lines carries very little current and hence do not require a large cross-sectional area.
2. This module compensates for a maximum drop of 10% of the nominal output voltage.
3. If the unit is already trimmed up, the available remote sense compensation range should be correspondingly reduced. The total voltage increased by trim and remote sense should not exceed 10% of the nominal output voltage.
4. When using remote sense compensation, all the resistance, parasitic inductance and capacitance of the system are incorporated within the feedback loop of this module. This can make an effect on the module's compensation, affecting the stability and dynamic response. A 0.1uF ceramic capacitor can be connected at the point of load to de-couple noise on the sense wires.
5. Recommend the connection of remote sense compensation as below figure. There are a resistor RS+ (100 ohm) from Vo+ to Sense+ and a resistor RS- (51 ohm) from Vo- to Sense- inside of this module.

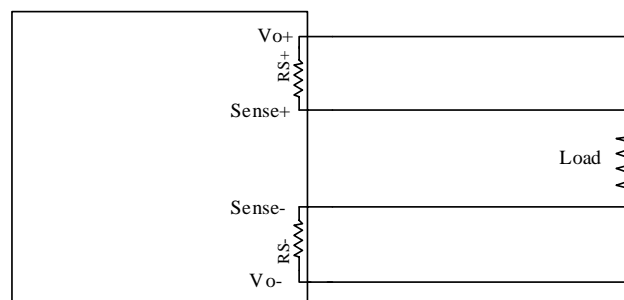

6. If not using remote sense compensation, please connect sense directly to output at module's pin, that is, connect sense+ to Vo+ and sense- to Vo- at module's pin, the shorter the better. See below figure.

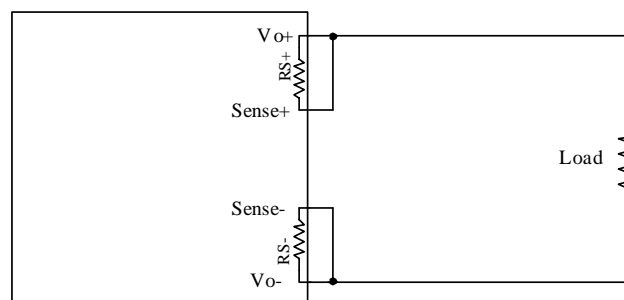

ISOLATED DC/DC CONVERTERS

24 Vdc Input 12 Vdc /20 A Output



Sep. 11, 2010

Bel Power Inc., a subsidiary of Bel Fuse Inc.

Over Current Protection

To provide protection in a fault output overload condition, the module is equipped with internal current-limiting circuitry and can endure current limiting for a few milli-seconds. If the over current condition persists beyond a few milliseconds, the module will shut down into hiccup mode and restart once every 800mS. The module operates normally when the output current goes into specified range. The typical average output current is 0.02A during hiccup.

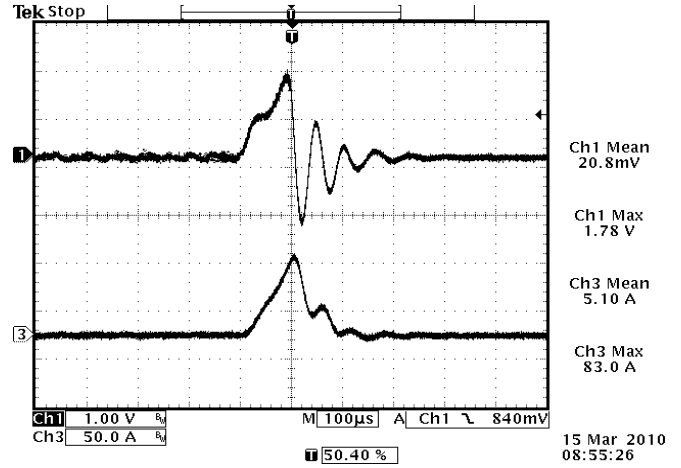
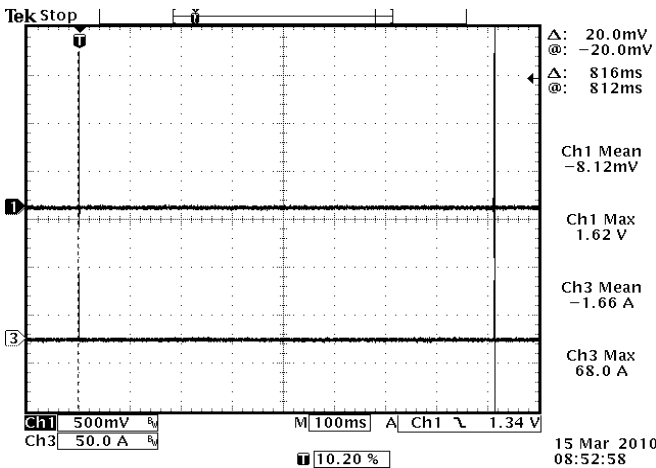

V_{in} = 24 V, Load in CC Mode
 CH1: Output Voltage
 CH3: Output Current

Expansion of on time portion

Over Voltage Protection

The output overvoltage protection consists of circuitry that monitors the voltage on the output terminals. If the voltage on the output terminals exceeds the over voltage protection threshold the module will shutdown into latch off mode. The overvoltage latch can be reset by either cycling the input power or toggling the on/off signal for one second at least.

Test setup:

R=249K

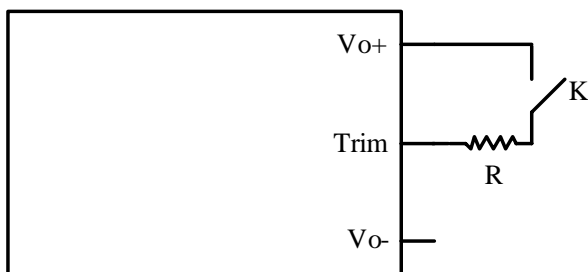

Waveform:
 CH1: Output voltage waveform
 CH2: Input voltage waveform
 CH3: Output Current waveform

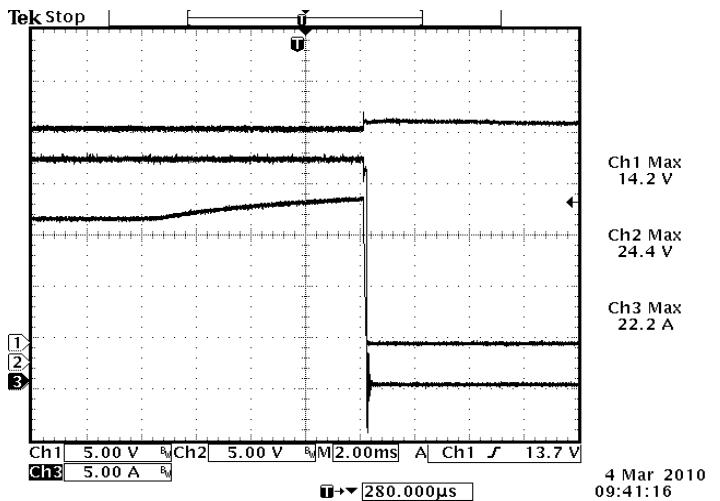

ISOLATED DC/DC CONVERTERS

24 Vdc Input 12 Vdc /20 A Output



Sep. 11, 2010

Bel Power Inc., a subsidiary of Bel Fuse Inc.

Over Temperature Protection

The OTP is achieved by thermistor RT and the threshold is set at 120C in non-latch mode; the hottest component Q5 reaches 120C with 200LFM air flow correspondingly. It will restart automatically when the temperature falls down to 100C. The protecting point will be varied a little under different conditions (air flow, ambient temperature, input voltage, load...).

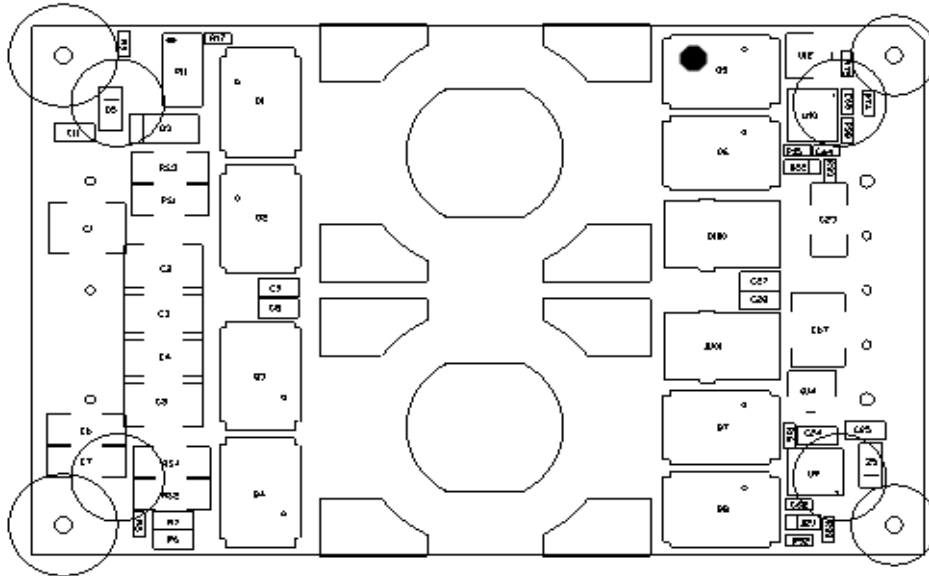

The hottest component on the top side: Q5

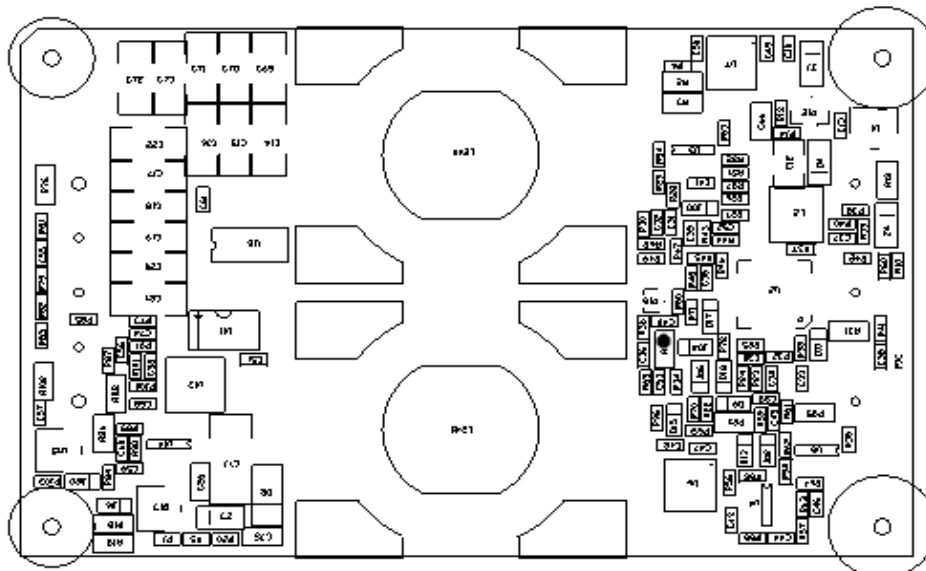

The thermistor on the bottom side: RT

ISOLATED DC/DC CONVERTERS

24 Vdc Input 12 Vdc /20 A Output



Sep. 11, 2010

Bel Power Inc., a subsidiary of Bel Fuse Inc.

Input Under-voltage Lockout

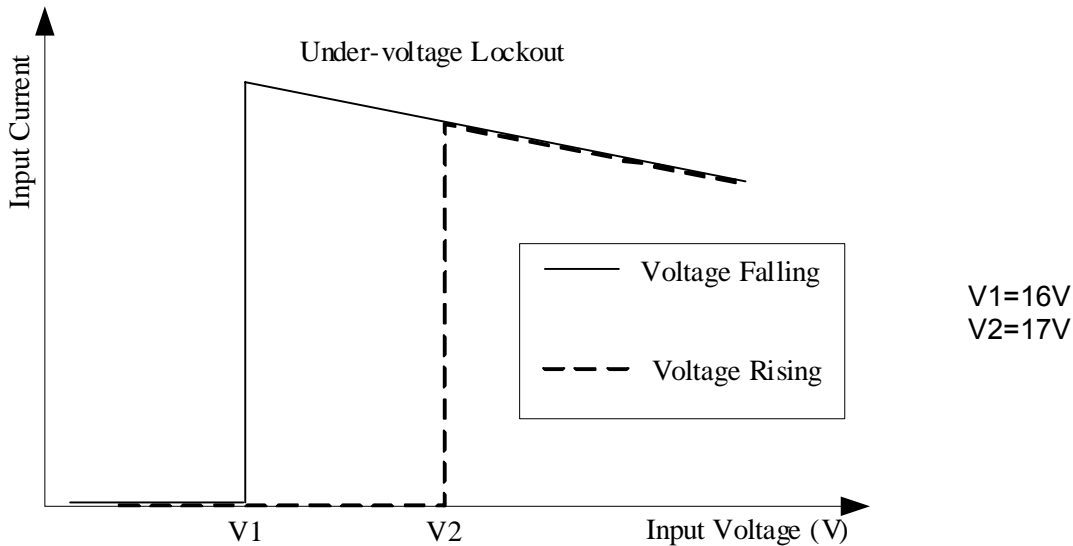

Fundamental Circuit Diagram

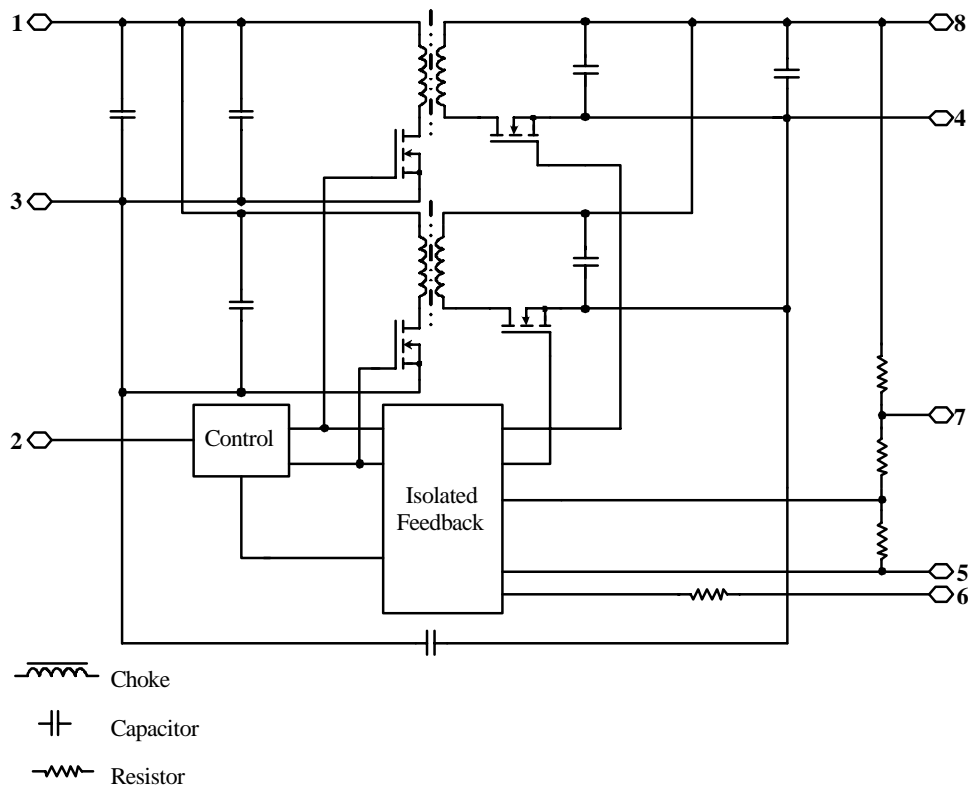

ISOLATED DC/DC CONVERTERS

24 Vdc Input 12 Vdc /20 A Output



Sep. 11, 2010

Bel Power Inc., a subsidiary of Bel Fuse Inc.

Safety & EMC

Safety

1. Material flammability UL94V-0
2. TUV Certification EN60950-1
3. UL Certification UL60950-1

EMC

1. Surge IEC61000-4-5
2. DC-DIP IEC61000-4-29
3. Conductive EMI EN55022 class A

Compliance to EN55022 class A (both q.peak and average) with the following inductive and capacitive filter

Setup:

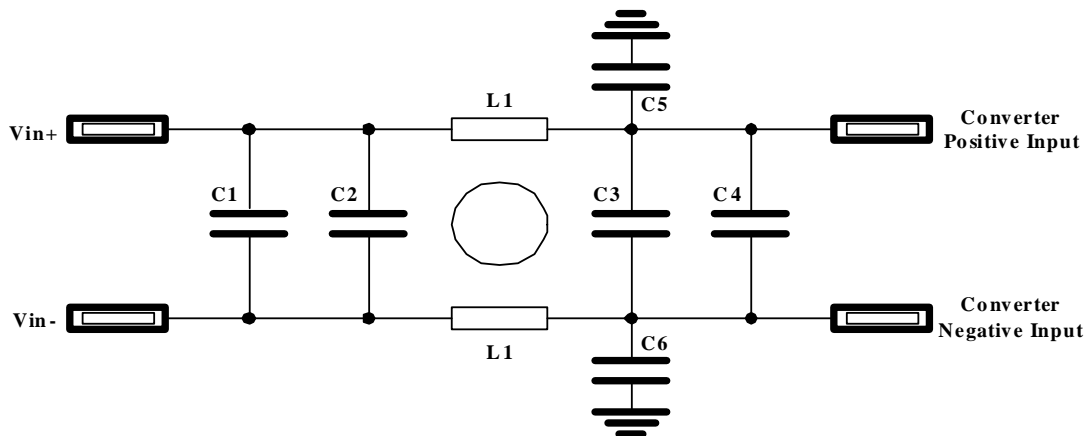

Item	Designator	Parameter	Vendor	Vendor P/N
1	C1	1uF/100V/1210	Murata	GRM32ER72A105KA01L
2	C2	1uF/100V/1210	Murata	GRM32ER72A105KA01L
3	C3	0.1uF/100V/1206	TDK	C3216X7R2A104K
4	C4	220µF/2000V, AL CAP	Nichicon	UHE2A221MHD6
5	C5	0.1uF/1000V/2220	Murata	GRM55DR73A104KW01L
6	C6	0.1uF/1000V/2220	Murata	GRM55DR73A104KW01L
7	T1	0.809mH	Pulse	P0429

ISOLATED DC/DC CONVERTERS

24 Vdc Input 12 Vdc /20 A Output



Sep. 11, 2010

Bel Power Inc., a subsidiary of Bel Fuse Inc.

Safety & EMC (continued)

Positive: Agilent 11:21:51 Dec 21, 2009 R T

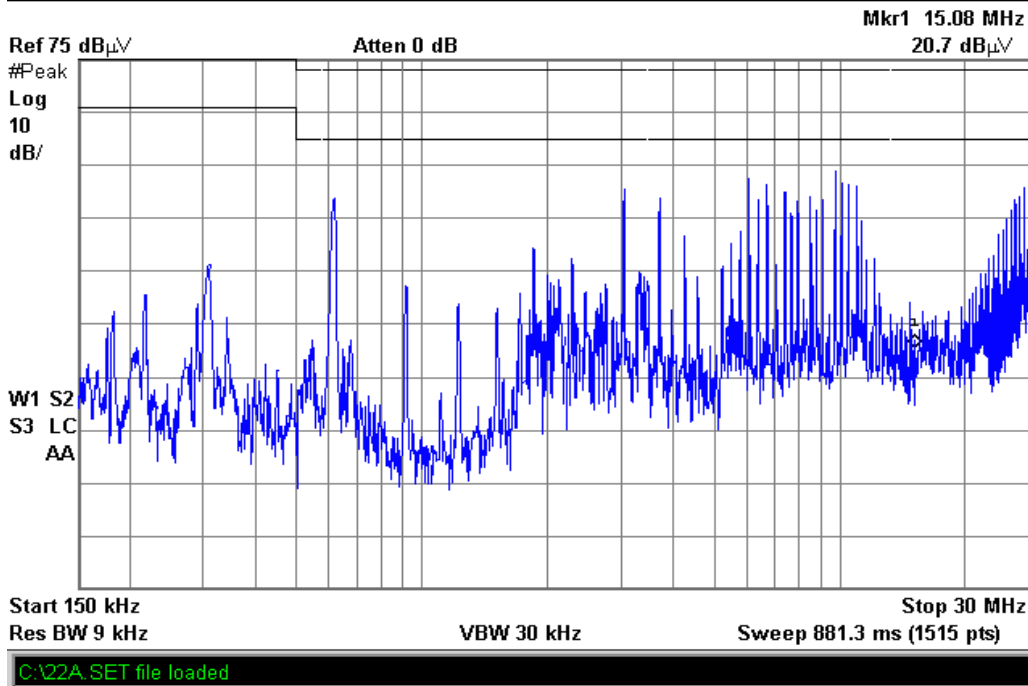

Negative: Agilent 11:21:39 Dec 21, 2009 R T

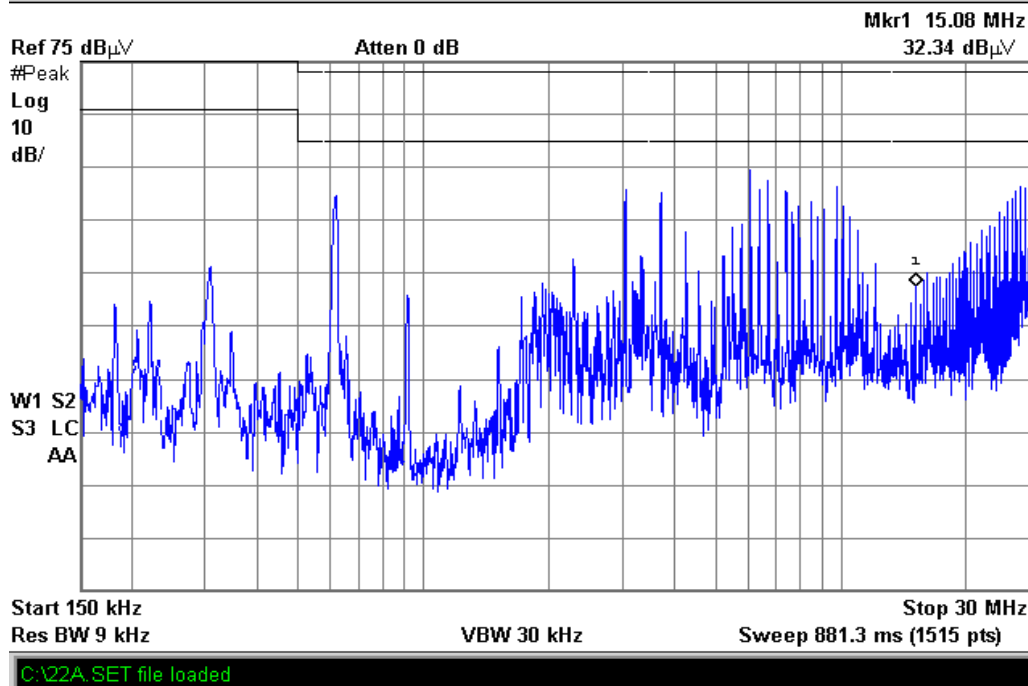

ISOLATED DC/DC CONVERTERS

24 Vdc Input 12 Vdc /20 A Output



Sep. 11, 2010

Bel Power Inc., a subsidiary of Bel Fuse Inc.

Layout

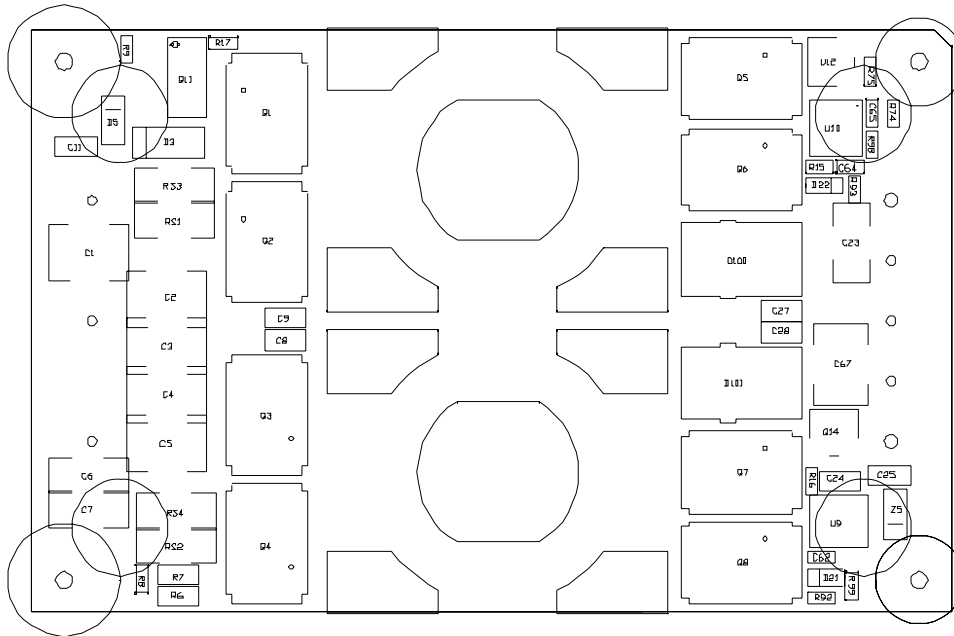

Layout of components on top side

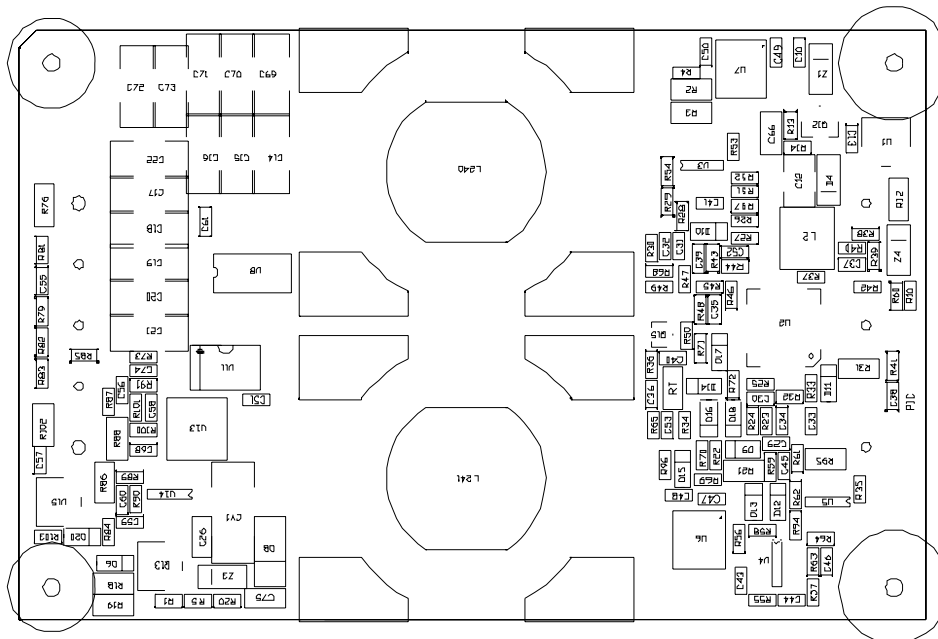

Layout of components on bottom side

ISOLATED DC/DC CONVERTERS

24 Vdc Input 12 Vdc /20 A Output



Sep. 11, 2010

Bel Power Inc., a subsidiary of Bel Fuse Inc.

Mechanical Outline

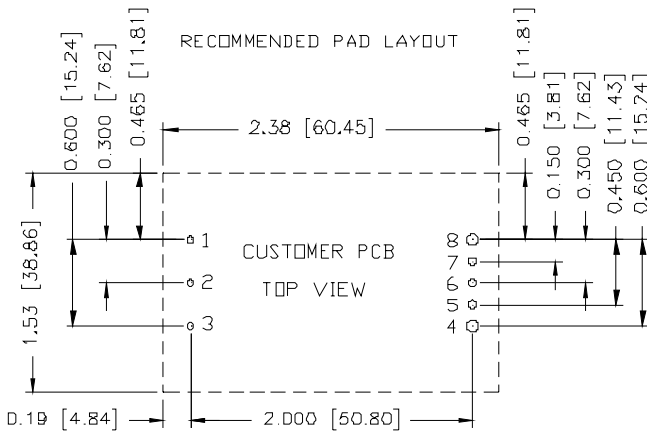
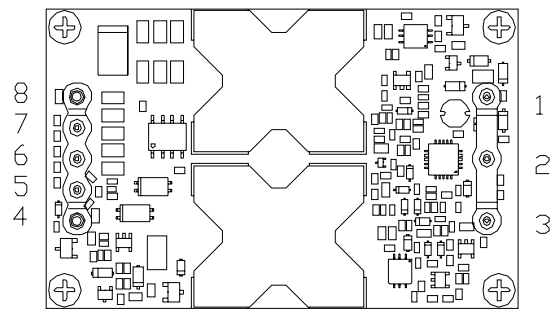
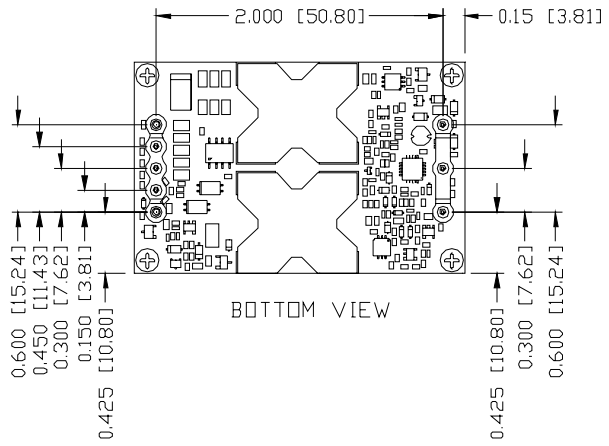
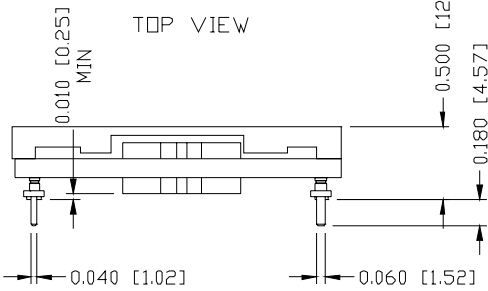
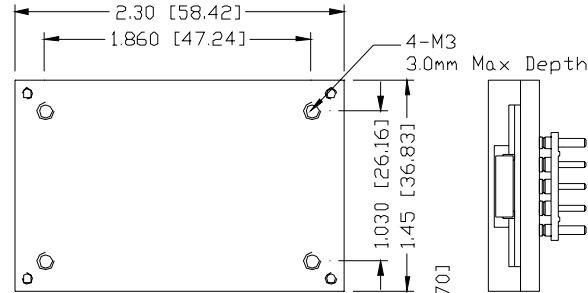

1,2,3,5,6,7 \varnothing 0.047 HOLE SIZE, \varnothing 0.08 min PAD SIZE
4,8 \varnothing 0.07 HOLE SIZE, \varnothing 0.10 min PAD SIZE

Pin Connections

pin#	function	pin size
1	Vin (+)	0.04"
2	On/Off	0.04"
3	Vin (-)	0.04"
4	Vout (-)	0.06"
5	RS-	0.04"
6	TRIM	0.04"
7	RS+	0.04"
8	Vout (+)	0.06"

Note: This module is recommended and compatible with Pb-Free Wave Soldering and must be soldered using a peak solder temperature of no more than 260 °C for less than 5 seconds.

Note:

- 1) All Pins: Material - Copper Alloy;
Finish – 3 micro inches minimum Gold over 50 micro inches minimum Nickel plate.
- 2) Undimensioned components are shown for visual reference only.
- 3) All dimensions in inches (mm); Tolerances: x.xx +/-0.02 in. (x.x +/-0.5mm) x.xxx +/-0.010 in. (x.xx +/-0.25mm).

ISOLATED DC/DC CONVERTERS

24 Vdc Input 12 Vdc /20 A Output



Sep. 11, 2010

Bel Power Inc., a subsidiary of Bel Fuse Inc.

Revision History

Date	Revision	Changes Detail	Approval
2008-07-22	PA	First release	XQ Han
2009-04-03	PB	Update mechanical drawing	XQ Han
2009-10-29	PC	Update input current, no load input current, remoted off input current, Input reflected ripple current, turn on voltage threshold, turn off voltage threshold, line regulation, output ripple and noise, output DC current limit, turn on time, transient response, efficiency, efficiency curve, switching frequency, over voltage protection and weight	XF Jiang
2010-09-11	D	<ol style="list-style-type: none">1. Change fixed frequency from 500kHz to 307kHz.2. Change max value of remote on/off from 12V to 18V; Add input transient voltage in absolute maximum ratings.3. Update no load input current, remote off input current, input reflected ripple current in input specifications.4. Change typical value of ripple and noise(pk-pk) from 80mV to 100mV; Update load regulation, line regulation, regulation over ambient temperature, turn on time, short circuit surge transient and transient response; Add rise time, output DC current limit, ripple and noise(pk-pk) under worse case in output specifications.5. Change min value of efficiency from 93% to 94%; Update switching frequency, over temperature protection, over voltage protection, isolation capacitance and FIT; Add input to case isolation voltage, output to case isolation voltage and isolation resistance in general specifications.6. Update TD, NR, TR, efficiency data and output trim equations; Add startup&shutdown, remote on/off, remote sense, OCP, OVP, OTP, UVLO, fundamental circuit diagram, safety&EMC and layout.	XF Jiang

RoHS Compliance

Complies with the European Directive 2002/95/EC, calling for the elimination of lead and other hazardous substances from electronic products.



©2010 Bel Fuse Inc. Specifications subject to change without notice. 091110

18

CORPORATE

Bel Fuse Inc.
206 Van Vorst Street
Jersey City, NJ 07302
Tel 201-432-0463
Fax 201-432-9542
www.belfuse.com

FAR EAST

Bel Fuse Ltd.
8F/ 8 Luk Hop Street
San Po Kong
Kowloon, Hong Kong
Tel 852-2328-5515
Fax 852-2352-3706
www.belfuse.com

EUROPE

Bel Fuse Europe Ltd.
Preston Technology Management Centre
Marsh Lane, Suite G7, Preston
Lancashire, PR1 8UD, U.K.
Tel 44-1772-556601
Fax 44-1772-888366
www.belfuse.com