

SPANSION™ Flash Memory

Data Sheet



September 2003

This document specifies SPANSION™ memory products that are now offered by both Advanced Micro Devices and Fujitsu. Although the document is marked with the name of the company that originally developed the specification, these products will be offered to customers of both AMD and Fujitsu.

Continuity of Specifications

There is no change to this datasheet as a result of offering the device as a SPANSION™ product. Future routine revisions will occur when appropriate, and changes will be noted in a revision summary.

Continuity of Ordering Part Numbers

AMD and Fujitsu continue to support existing part numbers beginning with "Am" and "MBM". To order these products, please use only the Ordering Part Numbers listed in this document.

For More Information

Please contact your local AMD or Fujitsu sales office for additional information about SPANSION™ memory solutions.



FLASH MEMORY

CMOS

16M (2M × 8/1M × 16) BIT

MBM29LV160T-80/-90/-12/MBM29LV160B-80/-90/-12

■ GENERAL DESCRIPTION

The MBM29LV160T/B is a 16M-bit, 3.0 V-only Flash memory organized as 2M bytes of 8 bits each or 1M words of 16 bits each. The MBM29LV160T/B is offered in a 48-pin TSOP (1), 48-pin CSOP and 48-ball FBGA packages. The device is designed to be programmed in-system with the standard system 3.0 V V_{CC} supply. 12.0 V V_{PP} and 5.0 V V_{CC} are not required for write or erase operations. The device can also be reprogrammed in standard EPROM programmers.

The standard MBM29LV160T/B offers access times of 80 ns and 120 ns, allowing operation of high-speed microprocessors without wait states. To eliminate bus contention the device has separate chip enable (\overline{CE}), write enable (\overline{WE}), and output enable (\overline{OE}) controls.

The MBM29LV160T/B is pin and command set compatible with JEDEC standard E²PROMs. Commands are written to the command register using standard microprocessor write timings. Register contents serve as input to an internal state-machine which controls the erase and programming circuitry. Write cycles also internally latch addresses and data needed for the programming and erase operations. Reading data out of the device is similar to reading from 5.0 V and 12.0 V Flash or EPROM devices.

The MBM29LV160T/B is programmed by executing the program command sequence. This will invoke the Embedded Program Algorithm which is an internal algorithm that automatically times the program pulse widths and verifies proper cell margins. Typically, each sector can be programmed and verified in about 0.5 seconds. Erase is accomplished by executing the erase command sequence. This will invoke the Embedded Erase Algorithm which is an internal algorithm that automatically preprograms the array if it is not already programmed before executing the erase operation. During erase, the device automatically times the erase pulse widths and verifies proper cell margins.

(Continued)

■ PRODUCT LINE UP

Part No.		MBM29LV160T/160B		
Ordering Part No.	$V_{CC} = 3.3 \text{ V}$ ^{+0.3 V} / _{-0.3 V}	-80	—	—
	$V_{CC} = 3.0 \text{ V}$ ^{+0.6 V} / _{-0.3 V}	—	-90	-12
Max Address Access Time (ns)		80	90	120
Max \overline{CE} Access Time (ns)		80	90	120
Max \overline{OE} Access Time (ns)		30	35	50

MBM29LV160T-80/-90/-12/MBM29LV160B-80/-90/-12

(Continued)

Any individual sector is typically erased and verified in 1.0 second. (If already preprogrammed.)

The device also features a sector erase architecture. The sector mode allows each sector to be erased and reprogrammed without affecting other sectors. The MBM29LV160T/B is erased when shipped from the factory.

The device features single 3.0 V power supply operation for both read and write functions. Internally generated and regulated voltages are provided for the program and erase operations. A low V_{CC} detector automatically inhibits write operations on the loss of power. The end of program or erase is detected by Data Polling of DQ_7 , by the Toggle Bit feature on DQ_6 , or the RY/\overline{BY} output pin. Once the end of a program or erase cycle has been completed, the device internally resets to the read mode.

The MBM29LV160T/B also has a hardware \overline{RESET} pin. When this pin is driven low, execution of any Embedded Program Algorithm or Embedded Erase Algorithm is terminated. The internal state machine is then reset to the read mode. The \overline{RESET} pin may be tied to the system reset circuitry. Therefore, if a system reset occurs during the Embedded Program Algorithm or Embedded Erase Algorithm, the device is automatically reset to the read mode and will have erroneous data stored in the address locations being programmed or erased. These locations need re-writing after the Reset. Resetting the device enables the system's microprocessor to read the boot-up firmware from the Flash memory.

Fujitsu's Flash technology combines years of Flash memory manufacturing experience to produce the highest levels of quality, reliability, and cost effectiveness. The MBM29LV160T/B memory electrically erases all bits within a sector simultaneously via Fowler-Nordhiem tunneling. The bytes/words are programmed one byte/word at a time using the EPROM programming mechanism of hot electron injection.

■ FEATURES

- **Single 3.0 V read, program and erase**
Minimizes system level power requirements
- **Compatible with JEDEC-standard commands**
Uses same software commands as E²PROMs
- **Compatible with JEDEC-standard world-wide pinouts**
48-pin TSOP (1) (Package suffix: PFTN-Normal Bend Type, PFTR-Reversed Bend Type)
48-pin CSOP (Package suffix: PCV)
48-ball FBGA (Package suffix: PBT)
- **Minimum 100,000 program/erase cycles**
- **High performance**
80 ns maximum access time
- **Sector erase architecture**
One 8K word, two 4K words, one 16K word, and thirty-one 32K words sectors in word mode
One 16K byte, two 8K bytes, one 32K byte, and thirty-one 64K bytes sectors in byte mode
Any combination of sectors can be concurrently erased. Also supports full chip erase
- **Boot Code Sector Architecture**
T = Top sector
B = Bottom sector
- **Embedded Erase^{TM*} Algorithms**
Automatically pre-programs and erases the chip or any sector
- **Embedded program^{TM*} Algorithms**
Automatically programs and verifies data at specified address
- **Data Polling and Toggle Bit feature for detection of program or erase cycle completion**
- **Ready/Busy output (RY/\overline{BY})**
Hardware method for detection of program or erase cycle completion

(Continued)

MBM29LV160T-80/-90/-12/MBM29LV160B-80/-90/-12

(Continued)

- **Automatic sleep mode**
When addresses remain stable, automatically switches themselves to low power mode
- **Low V_{CC} write inhibit ≤ 2.5 V**
- **Erase Suspend/Resume**
Suspends the erase operation to allow a read data and/or program in another sector within the same device
- **Sector protection**
Hardware method disables any combination of sectors from program or erase operations
- **Sector Protection set function by Extended sector Protect command**
- **Fast Programming Function by Extended Command**
- **Temporary sector unprotection**
Temporary sector unprotection via the \overline{RESET} pin
- **In accordance with CFI (Common Flash Memory Interface)**

*: Embedded Erase™ and Embedded Program™ are trademarks of Advanced Micro Devices, Inc.

■ PACKAGES

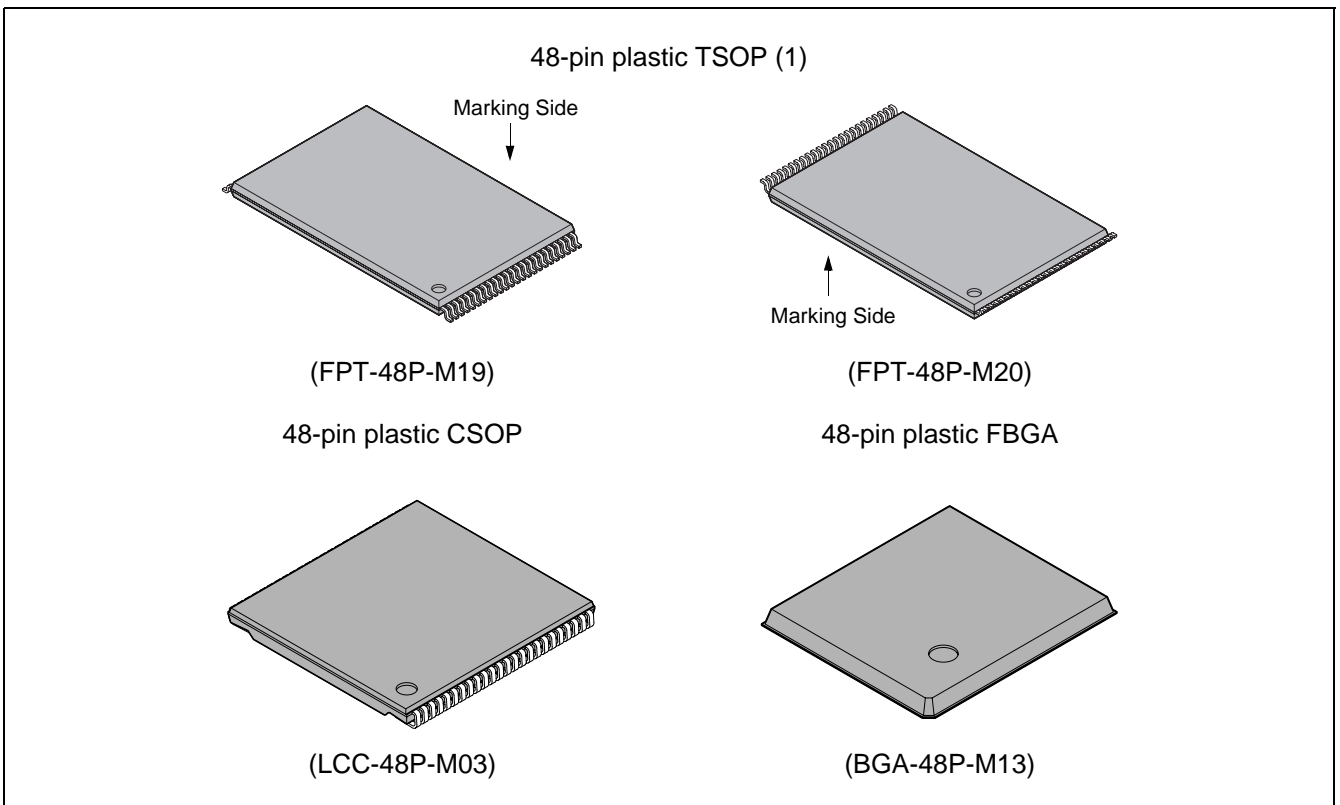

MBM29LV160T-80/-90/-12/MBM29LV160B-80/-90/-12

■ PIN ASSIGNMENTS

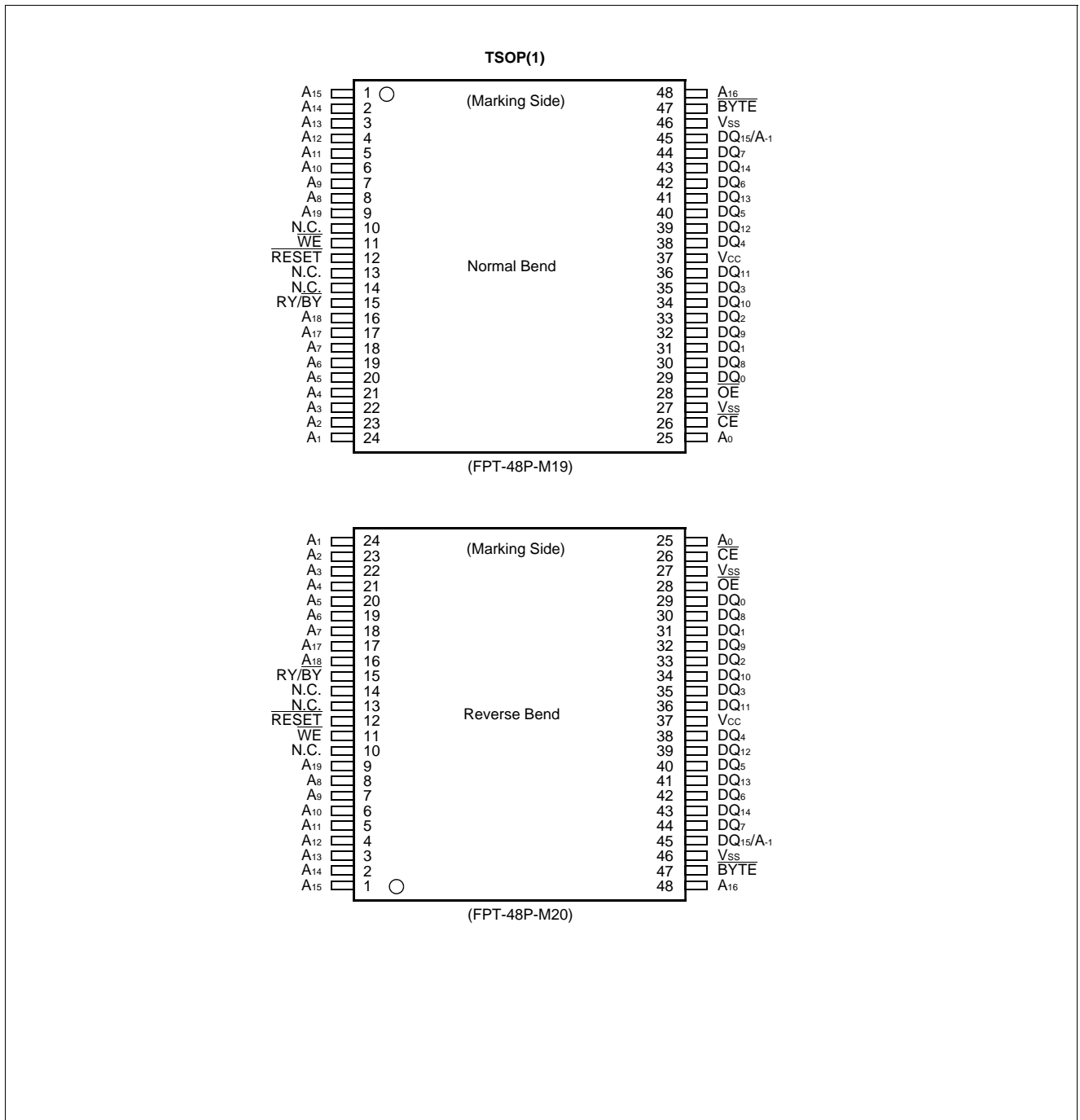

(Continued)

MBM29LV160T-80/-90/-12/MBM29LV160B-80/-90/-12

(Continued)

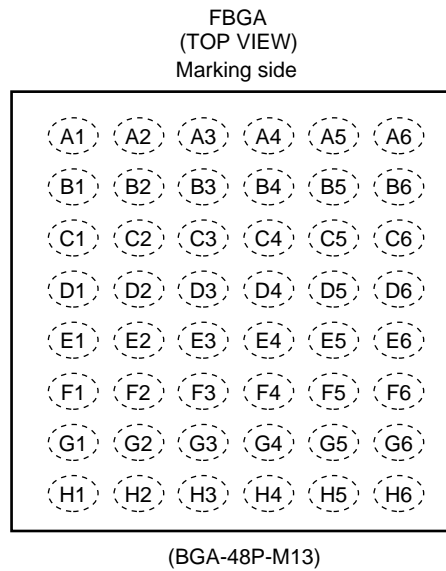
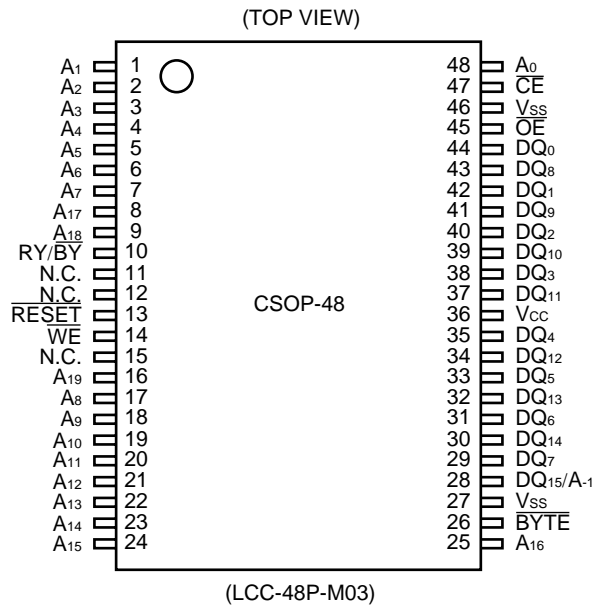

A1	A ₃	A2	A ₇	A3	RY/BY	A4	WE	A5	A ₉	A6	A ₁₃
B1	A ₄	B2	A ₁₇	B3	N.C.	B4	RESET	B5	A ₈	B6	A ₁₂
C1	A ₂	C2	A ₆	C3	A ₁₈	C4	N.C.	C5	A ₁₀	C6	A ₁₄
D1	A ₁	D2	A ₅	D3	N.C.	D4	A ₁₉	D5	A ₁₁	D6	A ₁₅
E1	A ₀	E2	DQ ₀	E3	DQ ₂	E4	DQ ₅	E5	DQ ₇	E6	A ₁₆
F1	CE	F2	DQ ₈	F3	DQ ₁₀	F4	DQ ₁₂	F5	DQ ₁₄	F6	BYTE
G1	OE	G2	DQ ₉	G3	DQ ₁₁	G4	V _{CC}	G5	DQ ₁₃	G6	DQ _{15/A-1}
H1	V _{SS}	H2	DQ ₁	H3	DQ ₃	H4	DQ ₄	H5	DQ ₆	H6	V _{SS}

MBM29LV160T-80/-90/-12/MBM29LV160B-80/-90/-12

■ PIN DESCRIPTIONS

Pin Name	Function
A ₁₉ to A ₀ , A-1	Address Inputs
DQ ₁₅ to DQ ₀	Data Inputs/Outputs
$\overline{\text{CE}}$	Chip Enable
$\overline{\text{OE}}$	Output Enable
$\overline{\text{WE}}$	Write Enable
RY/ $\overline{\text{BY}}$	Ready/Busy Output
$\overline{\text{RESET}}$	Hardware Reset Pin/Temporary Sector Unprotection
$\overline{\text{BYTE}}$	Selects 8-bit or 16-bit mode
N.C.	Pin Not Connected Internally
V _{ss}	Device Ground
V _{cc}	Device Power Supply

MBM29LV160T-80/-90/-12/MBM29LV160B-80/-90/-12

■ BLOCK DIAGRAM

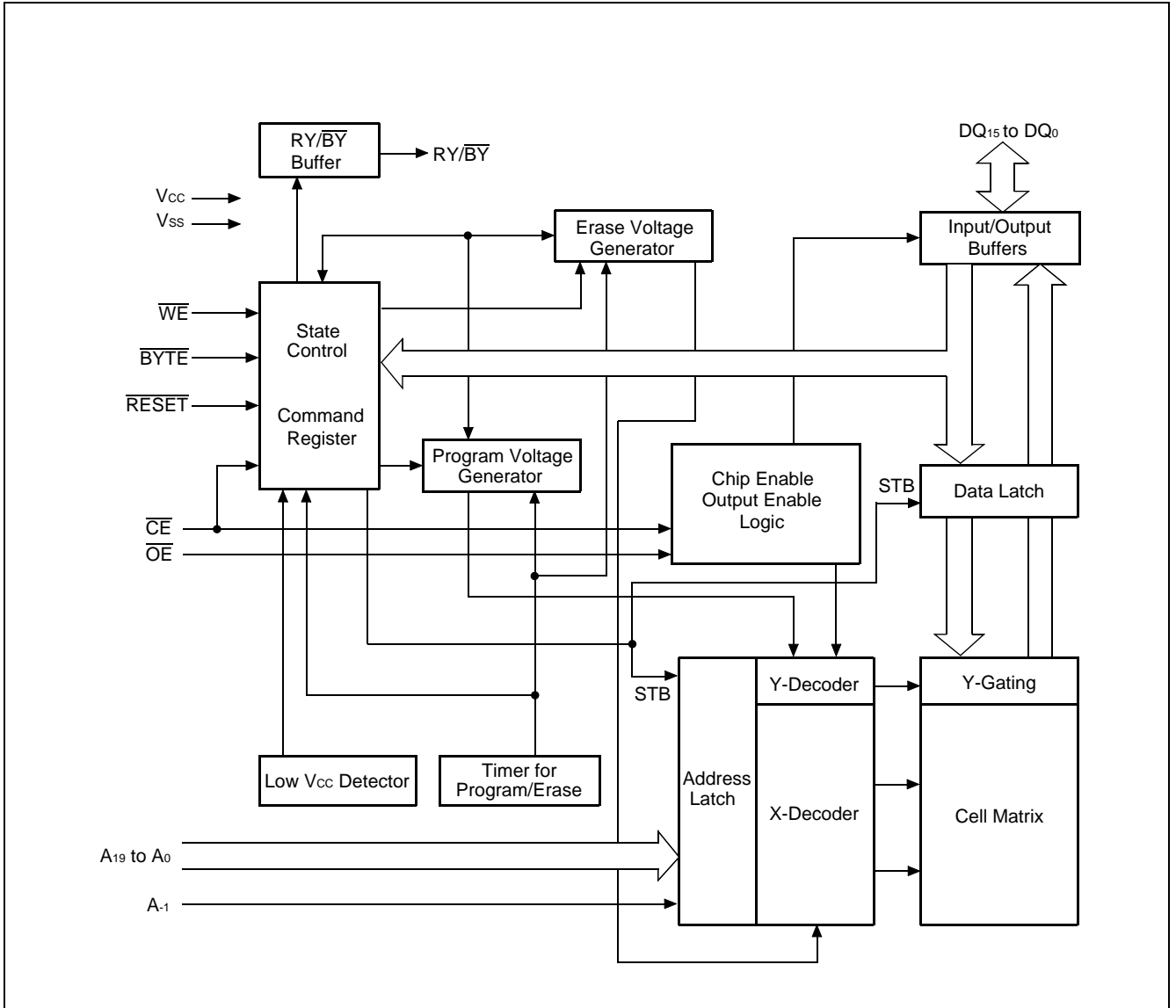

■ LOGIC SYMBOL

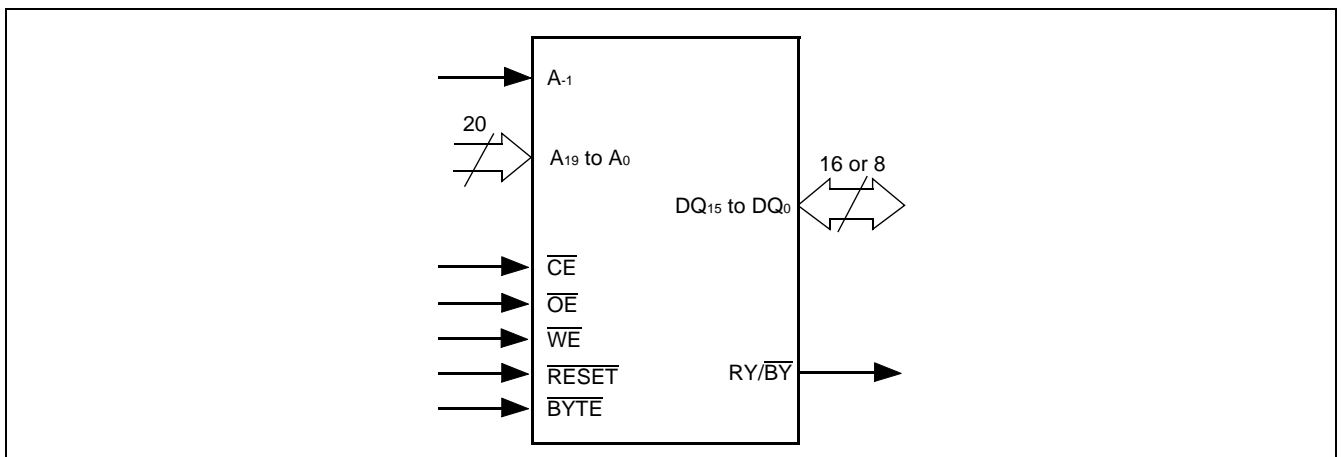

MBM29LV160T-80/-90/-12/MBM29LV160B-80/-90/-12

■ DEVICE BUS OPERATION

MBM29LV160T/B User Bus Operation Table ($\overline{\text{BYTE}} = V_{IH}$)

Operation	$\overline{\text{CE}}$	$\overline{\text{OE}}$	$\overline{\text{WE}}$	A ₀	A ₁	A ₆	A ₉	DQ ₁₅ to DQ ₀	$\overline{\text{RESET}}$
Auto-Select Manufacture Code *1	L	L	H	L	L	L	V _{ID}	Code	H
Auto-Select Device Code *1	L	L	H	H	L	L	V _{ID}	Code	H
Read *3	L	L	H	A ₀	A ₁	A ₆	A ₉	D _{OUT}	H
Standby	H	X	X	X	X	X	X	High-Z	H
Output Disable	L	H	H	X	X	X	X	High-Z	H
Write (Program/Erase)	L	H	L	A ₀	A ₁	A ₆	A ₉	D _{IN}	H
Enable Sector Protection *2, *4	L	V _{ID}	$\overline{\text{p}}$	L	H	L	V _{ID}	X	H
Verify Sector Protection *2, *4	L	L	H	L	H	L	V _{ID}	Code	H
Temporary Sector Unprotection *5	X	X	X	X	X	X	X	X	V _{ID}
Reset (Hardware)/Standby	X	X	X	X	X	X	X	High-Z	L

Legend: L = V_{IL}, H = V_{IH}, X = V_{IL} or V_{IH}. $\overline{\text{p}}$ = pulse input. See “■DC CHARACTERISTICS” for voltage levels.

*1 : Manufacturer and device codes may also be accessed via a command register write sequence. See “MBM29LV160T/B Standard Command Definitions Table”.

*2 : Refer to the section on Sector Protection.

*3 : $\overline{\text{WE}}$ can be V_{IL} if $\overline{\text{OE}}$ is V_{IL}, $\overline{\text{OE}}$ at V_{IH} initiates the write operations.

*4 : V_{CC} = 3.3 V ±10%

*5 : It is also used for the extended sector protection.

MBM29LV160T/B User Bus Operation Table ($\overline{\text{BYTE}} = V_{IL}$)

Operation	$\overline{\text{CE}}$	$\overline{\text{OE}}$	$\overline{\text{WE}}$	DQ ₁₅ /A ₋₁	A ₀	A ₁	A ₆	A ₉	DQ ₁₅ to DQ ₀	$\overline{\text{RESET}}$
Auto-Select Manufacture Code *1	L	L	H	L	L	L	L	V _{ID}	Code	H
Auto-Select Device Code *1	L	L	H	L	H	L	L	V _{ID}	Code	H
Read *3	L	L	H	A ₋₁	A ₀	A ₁	A ₆	A ₉	D _{OUT}	H
Standby	H	X	X	X	X	X	X	X	High-Z	H
Output Disable	L	H	H	X	X	X	X	X	High-Z	H
Write (Program/Erase)	L	H	L	A ₋₁	A ₀	A ₁	A ₆	A ₉	D _{IN}	H
Enable Sector Protection *2, *4	L	V _{ID}	$\overline{\text{p}}$	L	L	H	L	V _{ID}	X	H
Verify Sector Protection *2, *4	L	L	H	L	L	H	L	V _{ID}	Code	H
Temporary Sector Unprotection *5	X	X	X	X	X	X	X	X	X	V _{ID}
Reset (Hardware)/Standby	X	X	X	X	X	X	X	X	High-Z	L

Legend: L = V_{IL}, H = V_{IH}, X = V_{IL} or V_{IH}. $\overline{\text{p}}$ = pulse input. See “■DC CHARACTERISTICS” for voltage levels.

*1 : Manufacturer and device codes may also be accessed via a command register write sequence. See “MBM29LV160T/B Standard Command Definitions Table”.

*2 : Refer to the section on Sector Protection.

*3 : $\overline{\text{WE}}$ can be V_{IL} if $\overline{\text{OE}}$ is V_{IL}, $\overline{\text{OE}}$ at V_{IH} initiates the write operations.

*4 : V_{CC} = 3.3 V ±10%

*5 : It is also used for the extended sector protection.

MBM29LV160T-80/-90/-12/MBM29LV160B-80/-90/-12

MBM29LV160T/B Standard Command Definitions Table

Command Sequence *1, *2, *3, *5		Bus Write Cycles Req'd	First Bus Write Cycle		Second Bus Write Cycle		Third Bus Write Cycle		Fourth Bus Read/Write Cycle		Fifth Bus Write Cycle		Sixth Bus Write Cycle	
			Addr	Data	Addr	Data	Addr	Data	Addr	Data	Addr	Data	Addr	Data
Read/Reset *6	Word /Byte	1	XXh	F0h	—	—	—	—	—	—	—	—	—	—
Read/Reset *6	Word	3	555h	AAh	2AAh	55h	555h	F0h	RA	RD	—	—	—	—
	Byte		AAAh		555h		AAAh							
Autoselect	Word	3	555h	AAh	2AAh	55h	555h	90h	—	—	—	—	—	—
	Byte		AAAh		555h		AAAh							
Byte/Word Program *3, *4	Word	4	555h	AAh	2AAh	55h	555h	A0h	PA	PD	—	—	—	—
	Byte		AAAh		555h		AAAh							
Chip Erase	Word	6	555h	AAh	2AAh	55h	555h	80h	555h	AAh	2AAh	55h	555h	10h
	Byte		AAAh		555h		AAAh		555h					
Sector Erase *3	Word	6	555h	AAh	2AAh	55h	555h	80h	555h	AAh	2AAh	55h	SA	30h
	Byte		AAAh		555h		AAAh		555h					
Sector Erase Suspend	Word /Byte	1	XXh	B0h	—	—	—	—	—	—	—	—	—	—
Sector Erase Resume	Word /Byte	1	XXh	30h	—	—	—	—	—	—	—	—	—	—

*1: Address bits A₁₉ to A₁₁ = X = "H" or "L" for all address commands except or Program Address (PA) and Sector Address (SA).

*2: Bus operations are defined in "MBM29LV160T/B User Bus Operation Tables ($\overline{\text{BYTE}} = V_{IH}$ and $\overline{\text{BYTE}} = V_{IL}$)".

*3: RA= Address of the memory location to be read.

PA = Address of the memory location to be programmed. Addresses are latched on the falling edge of the $\overline{\text{WE}}$ pulse.

SA= Address of the sector to be erased. The combination of A₁₉, A₁₈, A₁₇, A₁₆, A₁₅, A₁₄, A₁₃, and A₁₂ will uniquely select any sector.

*4: RD= Data read from location RA during read operation.

PD= Data to be programmed at location PA. Data is latched on the rising edge of $\overline{\text{WE}}$.

*5: The system should generate the following address patterns:

Word Mode: 555h or 2AAh to addresses A₁₀ to A₀

Byte Mode: AAAh or 555h to addresses A₁₀ to A₋₁

*6: Both Read/Reset commands are functionally equivalent, resetting the device to the read mode.

Note: The command combinations not described in "MBM29LV160T/B Standard Command Definitions" and "MBM29LV160T/B Extended Command Definitions" are illegal.

MBM29LV160T-80/-90/-12/MBM29LV160B-80/-90/-12

MBM29LV160T/B Extended Command Definitions Table

Command Sequence		Bus Write Cycles Req'd	First Bus Write Cycle		Second Bus Write Cycle		Third Bus Write Cycle		Fourth Bus Read Cycle	
			Addr	Data	Addr	Data	Addr	Data	Addr	Data
Set to Fast Mode	Word	3	55h	AAh	2AAh	55h	55h	20h	—	—
	Byte		AAAh		55h		AAAh			
Fast Program *1	Word	2	XXXh	A0h	PA	PD	—	—	—	—
	Byte		XXXh							
Reset from Fast Mode *1	Word	2	XXXh	90h	XXXh	F0h *4	—	—	—	—
	Byte		XXXh							
Query Command *2	Word	2	55h	98h	—	—	—	—	—	—
	Byte		AAh							
Extended Sector Protect *3	Word	4	XXXh	60h	SPA	60h	SPA	40h	SPA	SD
	Byte									

SPA : Sector Address to be protected. Set sector address (SA) and (A₆, A₁, A₀) = (0, 1, 0).

SD : Sector protection verify data. Output 01h at protected sector addresses and output 00h at unprotected sector addresses.

*1 : This command is valid during fast mode.

*2 : The valid addresses are A₆ to A₀. The other addresses are "Don't care".

*3 : This command is valid while V_{ID} = $\overline{\text{RESET}}$.

*4 : The data "00h" is also acceptable.

MBM29LV160T-80/-90/-12/MBM29LV160B-80/-90/-12

MBM29LV160T/B Sector Protection Verify Autoselect Code Table

Type		A ₁₉ to A ₁₂	A ₆	A ₁	A ₀	A ₋₁ *1	Code (HEX)
Manufacture's Code		X	V _{IL}	V _{IL}	V _{IL}	V _{IL}	04h
Device Code	MBM29LV160T	Byte	X	V _{IL}	V _{IL}	V _{IH}	V _{IL}
		Word					X
	MBM29LV160B	Byte	X	V _{IL}	V _{IL}	V _{IH}	V _{IL}
		Word					X
Sector Protection		Sector Addresses	V _{IL}	V _{IH}	V _{IL}	V _{IL}	01h*2

*1: A₋₁ is for Byte mode. At Byte mode, DQ₁₄ to DQ₈ are High-Z and DQ₁₅ is A₋₁, the lowest address.

*2: Outputs 01h at protected sector addresses and outputs 00h at unprotected sector addresses.

Extended Autoselect Code Table

Type		Code	DQ ₁₅	DQ ₁₄	DQ ₁₃	DQ ₁₂	DQ ₁₁	DQ ₁₀	DQ ₉	DQ ₈	DQ ₇	DQ ₆	DQ ₅	DQ ₄	DQ ₃	DQ ₂	DQ ₁	DQ ₀	
Manufacture's Code		04h	A ₋₁ /0	0	0	0	0	0	0	0	0	0	0	0	0	1	0	0	
Device Code	MBM29LV160T	(B)*	C4h	A ₋₁	HI-Z	HI-Z	HI-Z	HI-Z	HI-Z	HI-Z	1	1	0	0	0	1	0	0	
		(W)	22C4h	0	0	1	0	0	0	1	0	1	1	0	0	0	1	0	0
	MBM29LV160B	(B)*	49h	A ₋₁	HI-Z	HI-Z	HI-Z	HI-Z	HI-Z	HI-Z	HI-Z	0	1	0	0	1	0	0	1
		(W)	2249h	0	0	1	0	0	0	1	0	0	1	0	0	1	0	0	1
Sector Protection		01h	A ₋₁ /0	0	0	0	0	0	0	0	0	0	0	0	0	0	0	1	

(B): Byte mode

(W): Word mode

HI-Z : High-Z

* : At Byte mode, DQ₁₄ to DQ₈ are High-Z and DQ₁₅ is A₋₁, the lowest address.

MBM29LV160T-80/-90/-12/MBM29LV160B-80/-90/-12

■ FLEXIBLE SECTOR-ERASE ARCHITECTURE

- One 8K word, two 4K words, one 16K word, and thirty-one 32K words sectors in word mode.
- One 16K byte, two 8K bytes, one 32K byte, and thirty-one 64K bytes sectors in byte mode.
- Individual-sector, multiple-sector, or bulk-erase capability.
- Individual or multiple-sector protection is user definable.

MBM29LV160T Top Boot Sector Architecture

Sector	Sector Size	(× 8) Address Range	(× 16) Address Range
SA0	64 Kbytes or 32 Kwords	00000h to 0FFFFh	00000h to 07FFFh
SA1	64 Kbytes or 32 Kwords	10000h to 1FFFFh	08000h to 0FFFFh
SA2	64 Kbytes or 32 Kwords	20000h to 2FFFFh	10000h to 17FFFh
SA3	64 Kbytes or 32 Kwords	30000h to 3FFFFh	18000h to 1FFFFh
SA4	64 Kbytes or 32 Kwords	40000h to 4FFFFh	20000h to 27FFFh
SA5	64 Kbytes or 32 Kwords	50000h to 5FFFFh	28000h to 2FFFFh
SA6	64 Kbytes or 32 Kwords	60000h to 6FFFFh	30000h to 37FFFh
SA7	64 Kbytes or 32 Kwords	70000h to 7FFFFh	38000h to 3FFFFh
SA8	64 Kbytes or 32 Kwords	80000h to 8FFFFh	40000h to 47FFFh
SA9	64 Kbytes or 32 Kwords	90000h to 9FFFFh	48000h to 4FFFFh
SA10	64 Kbytes or 32 Kwords	A0000h to AFFFFh	50000h to 57FFFh
SA11	64 Kbytes or 32 Kwords	B0000h to BFFFFh	58000h to 5FFFFh
SA12	64 Kbytes or 32 Kwords	C0000h to CFFFFh	60000h to 67FFFh
SA13	64 Kbytes or 32 Kwords	D0000h to DFFFFh	68000h to 6FFFFh
SA14	64 Kbytes or 32 Kwords	E0000h to EFFFFh	70000h to 77FFFh
SA15	64 Kbytes or 32 Kwords	F0000h to FFFFFh	78000h to 7FFFFh
SA16	64 Kbytes or 32 Kwords	100000h to 10FFFFh	80000h to 87FFFh
SA17	64 Kbytes or 32 Kwords	110000h to 11FFFFh	88000h to 8FFFFh
SA18	64 Kbytes or 32 Kwords	120000h to 12FFFFh	90000h to 97FFFh
SA19	64 Kbytes or 32 Kwords	130000h to 13FFFFh	98000h to 9FFFFh
SA20	64 Kbytes or 32 Kwords	140000h to 14FFFFh	A0000h to A7FFFh
SA21	64 Kbytes or 32 Kwords	150000h to 15FFFFh	A8000h to AFFFFh
SA22	64 Kbytes or 32 Kwords	160000h to 16FFFFh	B0000h to B7FFFh
SA23	64 Kbytes or 32 Kwords	170000h to 17FFFFh	B8000h to BFFFFh
SA24	64 Kbytes or 32 Kwords	180000h to 18FFFFh	C0000h to C7FFFh
SA25	64 Kbytes or 32 Kwords	190000h to 19FFFFh	C8000h to CFFFFh
SA26	64 Kbytes or 32 Kwords	1A0000h to 1AFFFFh	D0000h to D7FFFh
SA27	64 Kbytes or 32 Kwords	1B0000h to 1BFFFFh	D8000h to DFFFFh
SA28	64 Kbytes or 32 Kwords	1C0000h to 1CFFFFh	E0000h to E7FFFh
SA29	64 Kbytes or 32 Kwords	1D0000h to 1DFFFFh	E8000h to EFFFFh
SA30	64 Kbytes or 32 Kwords	1E0000h to 1EFFFFh	F0000h to F7FFFh
SA31	32 Kbytes or 16 Kwords	1F0000h to 1F7FFFh	F8000h to FBFFFh
SA32	8 Kbytes or 4 Kwords	1F8000h to 1F9FFFh	FC000h to FCFFFh
SA33	8 Kbytes or 4 Kwords	1FA000h to 1FBFFFh	FD000h to FDFFFh
SA34	16 Kbytes or 8 Kwords	1FC000h to 1FFFFFh	FE000h to FFFFFh

MBM29LV160T-80/-90/-12/MBM29LV160B-80/-90/-12

MBM29LV160B Bottom Boot Sector Architecture

Sector	Sector Size	(× 8) Address Range	(× 16) Address Range
SA0	16 Kbytes or 8 Kwords	00000h to 03FFFh	00000h to 01FFFh
SA1	8 Kbytes or 4 Kwords	04000h to 05FFFh	02000h to 02FFFh
SA2	8 Kbytes or 4 Kwords	06000h to 07FFFh	03000h to 03FFFh
SA3	32 Kbytes or 16 Kwords	08000h to 0FFFFh	04000h to 07FFFh
SA4	64 Kbytes or 32 Kwords	10000h to 1FFFFh	08000h to 0FFFFh
SA5	64 Kbytes or 32 Kwords	20000h to 2FFFFh	10000h to 17FFFh
SA6	64 Kbytes or 32 Kwords	30000h to 3FFFFh	18000h to 1FFFFh
SA7	64 Kbytes or 32 Kwords	40000h to 4FFFFh	20000h to 27FFFh
SA8	64 Kbytes or 32 Kwords	50000h to 5FFFFh	28000h to 2FFFFh
SA9	64 Kbytes or 32 Kwords	60000h to 6FFFFh	30000h to 37FFFh
SA10	64 Kbytes or 32 Kwords	70000h to 7FFFFh	38000h to 3FFFFh
SA11	64 Kbytes or 32 Kwords	80000h to 8FFFFh	40000h to 47FFFh
SA12	64 Kbytes or 32 Kwords	90000h to 9FFFFh	48000h to 4FFFFh
SA13	64 Kbytes or 32 Kwords	A0000h to AFFFFh	50000h to 57FFFh
SA14	64 Kbytes or 32 Kwords	B0000h to BFFFFh	58000h to 5FFFFh
SA15	64 Kbytes or 32 Kwords	C0000h to CFFFFh	60000h to 67FFFh
SA16	64 Kbytes or 32 Kwords	D0000h to DFFFFh	68000h to 6FFFFh
SA17	64 Kbytes or 32 Kwords	E0000h to EFFFFh	70000h to 77FFFh
SA18	64 Kbytes or 32 Kwords	F0000h to FFFFFh	78000h to 7FFFFh
SA19	64 Kbytes or 32 Kwords	100000h to 10FFFFh	80000h to 87FFFh
SA20	64 Kbytes or 32 Kwords	110000h to 11FFFFh	88000h to 8FFFFh
SA21	64 Kbytes or 32 Kwords	120000h to 12FFFFh	90000h to 97FFFh
SA22	64 Kbytes or 32 Kwords	130000h to 13FFFFh	98000h to 9FFFFh
SA23	64 Kbytes or 32 Kwords	140000h to 14FFFFh	A0000h to A7FFFh
SA24	64 Kbytes or 32 Kwords	150000h to 15FFFFh	A8000h to AFFFFh
SA25	64 Kbytes or 32 Kwords	160000h to 16FFFFh	B0000h to B7FFFh
SA26	64 Kbytes or 32 Kwords	170000h to 17FFFFh	B8000h to BFFFFh
SA27	64 Kbytes or 32 Kwords	180000h to 18FFFFh	C0000h to C7FFFh
SA28	64 Kbytes or 32 Kwords	190000h to 19FFFFh	C8000h to CFFFFh
SA29	64 Kbytes or 32 Kwords	1A0000h to 1AFFFFh	D0000h to D7FFFh
SA30	64 Kbytes or 32 Kwords	1B0000h to 1BFFFFh	D8000h to DFFFFh
SA31	64 Kbytes or 32 Kwords	1C0000h to 1CFFFFh	E0000h to E7FFFh
SA32	64 Kbytes or 32 Kwords	1D0000h to 1DFFFFh	E8000h to EFFFFh
SA33	64 Kbytes or 32 Kwords	1E0000h to 1EFFFFh	F0000h to F7FFFh
SA34	64 Kbytes or 32 Kwords	1F0000h to 1FFFFh	F8000h to FFFFFh

MBM29LV160T-80/-90/-12/MBM29LV160B-80/-90/-12

Sector Address Table (MBM29LV160T)

Sector Address	A ₁₉	A ₁₈	A ₁₇	A ₁₆	A ₁₅	A ₁₄	A ₁₃	A ₁₂	(× 8) Address Range	(× 16) Address Range
SA0	0	0	0	0	0	X	X	X	00000h to 0FFFFh	00000h to 07FFFh
SA1	0	0	0	0	1	X	X	X	10000h to 1FFFFh	08000h to 0FFFFh
SA2	0	0	0	1	0	X	X	X	20000h to 2FFFFh	10000h to 17FFFh
SA3	0	0	0	1	1	X	X	X	30000h to 3FFFFh	18000h to 1FFFFh
SA4	0	0	1	0	0	X	X	X	40000h to 4FFFFh	20000h to 27FFFh
SA5	0	0	1	0	1	X	X	X	50000h to 5FFFFh	28000h to 2FFFFh
SA6	0	0	1	1	0	X	X	X	60000h to 6FFFFh	30000h to 37FFFh
SA7	0	0	1	1	1	X	X	X	70000h to 7FFFFh	38000h to 3FFFFh
SA8	0	1	0	0	0	X	X	X	80000h to 8FFFFh	40000h to 47FFFh
SA9	0	1	0	0	1	X	X	X	90000h to 9FFFFh	48000h to 4FFFFh
SA10	0	1	0	1	0	X	X	X	A0000h to AFFFFh	50000h to 57FFFh
SA11	0	1	0	1	1	X	X	X	B0000h to BFFFFh	58000h to 5FFFFh
SA12	0	1	1	0	0	X	X	X	C0000h to CFFFFh	60000h to 67FFFh
SA13	0	1	1	0	1	X	X	X	D0000h to DFFFFh	68000h to 6FFFFh
SA14	0	1	1	1	0	X	X	X	E0000h to EFFFFh	70000h to 77FFFh
SA15	0	1	1	1	1	X	X	X	F0000h to FFFFFh	78000h to 7FFFFh
SA16	1	0	0	0	0	X	X	X	100000h to 10FFFFh	80000h to 87FFFh
SA17	1	0	0	0	1	X	X	X	110000h to 11FFFFh	88000h to 8FFFFh
SA18	1	0	0	1	0	X	X	X	120000h to 12FFFFh	90000h to 97FFFh
SA19	1	0	0	1	1	X	X	X	130000h to 13FFFFh	98000h to 9FFFFh
SA20	1	0	1	0	0	X	X	X	140000h to 14FFFFh	A0000h to A7FFFh
SA21	1	0	1	0	1	X	X	X	150000h to 15FFFFh	A8000h to AFFFFh
SA22	1	0	1	1	0	X	X	X	160000h to 16FFFFh	B0000h to B7FFFh
SA23	1	0	1	1	1	X	X	X	170000h to 17FFFFh	B8000h to BFFFFh
SA24	1	1	0	0	0	X	X	X	180000h to 18FFFFh	C0000h to C7FFFh
SA25	1	1	0	0	1	X	X	X	190000h to 19FFFFh	C8000h to CFFFFh
SA26	1	1	0	1	0	X	X	X	1A0000h to 1AFFFFh	D0000h to D7FFFh
SA27	1	1	0	1	1	X	X	X	1B0000h to 1BFFFFh	D8000h to DFFFFh
SA28	1	1	1	0	0	X	X	X	1C0000h to 1CFFFFh	E0000h to E7FFFh
SA29	1	1	1	0	1	X	X	X	1D0000h to 1DFFFFh	E8000h to EFFFFh
SA30	1	1	1	1	0	X	X	X	1E0000h to 1EFFFFh	F0000h to F7FFFh
SA31	1	1	1	1	1	0	X	X	1F0000h to 1F7FFFh	F8000h to FBFFFh
SA32	1	1	1	1	1	1	0	0	1F8000h to 1F9FFFh	FC000h to FCFFFh
SA33	1	1	1	1	1	1	0	1	1FA000h to 1FBFFFh	FD000h to FDFFFh
SA34	1	1	1	1	1	1	1	X	1FC000h to 1FFFFFh	FE000h to FEFFFh

MBM29LV160T-80/-90/-12/MBM29LV160B-80/-90/-12

Sector Address Table (MBM29LV160B)

Sector Address	A ₁₉	A ₁₈	A ₁₇	A ₁₆	A ₁₅	A ₁₄	A ₁₃	A ₁₂	(× 8) Address Range	(× 16) Address Range
SA0	0	0	0	0	0	0	0	X	00000h to 03FFFh	00000h to 01FFFh
SA1	0	0	0	0	0	0	1	0	04000h to 05FFFh	02000h to 02FFFh
SA2	0	0	0	0	0	0	1	1	06000h to 07FFFh	03000h to 03FFFh
SA3	0	0	0	0	0	1	0	X	08000h to 0FFFFh	04000h to 07FFFh
SA4	0	0	0	0	1	X	X	X	10000h to 1FFFFh	08000h to 0FFFFh
SA5	0	0	0	1	0	X	X	X	20000h to 2FFFFh	10000h to 17FFFh
SA6	0	0	0	1	1	X	X	X	30000h to 3FFFFh	18000h to 1FFFFh
SA7	0	0	1	0	0	X	X	X	40000h to 4FFFFh	20000h to 27FFFh
SA8	0	0	1	0	1	X	X	X	50000h to 5FFFFh	28000h to 2FFFFh
SA9	0	0	1	1	0	X	X	X	60000h to 6FFFFh	30000h to 37FFFh
SA10	0	0	1	1	1	X	X	X	70000h to 7FFFFh	38000h to 3FFFFh
SA11	0	1	0	0	0	X	X	X	80000h to 8FFFFh	40000h to 47FFFh
SA12	0	1	0	0	1	X	X	X	90000h to 9FFFFh	48000h to 4FFFFh
SA13	0	1	0	1	0	X	X	X	A0000h to AFFFFh	50000h to 57FFFh
SA14	0	1	0	1	1	X	X	X	B0000h to BFFFFh	58000h to 5FFFFh
SA15	0	1	1	0	0	X	X	X	C0000h to CFFFFh	60000h to 67FFFh
SA16	0	1	1	0	1	X	X	X	D0000h to DFFFFh	68000h to 6FFFFh
SA17	0	1	1	1	0	X	X	X	E0000h to EFFFFh	70000h to 77FFFh
SA18	0	1	1	1	1	X	X	X	F0000h to FFFFFh	78000h to 7FFFFh
SA19	1	0	0	0	0	X	X	X	100000h to 1FFFFFFh	80000h to 87FFFh
SA20	1	0	0	0	1	X	X	X	110000h to 11FFFFh	88000h to 8FFFFh
SA21	1	0	0	1	0	X	X	X	120000h to 12FFFFh	90000h to 97FFFh
SA22	1	0	0	1	1	X	X	X	130000h to 13FFFFh	98000h to 9FFFFh
SA23	1	0	1	0	0	X	X	X	140000h to 14FFFFh	A0000h to A7FFFh
SA24	1	0	1	0	1	X	X	X	150000h to 15FFFFh	A8000h to 8FFFFh
SA25	1	0	1	1	0	X	X	X	160000h to 16FFFFh	B0000h to B7FFFh
SA26	1	0	1	1	1	X	X	X	170000h to 17FFFFh	B8000h to BFFFFh
SA27	1	1	0	0	0	X	X	X	180000h to 18FFFFh	C0000h to C7FFFh
SA28	1	1	0	0	1	X	X	X	190000h to 19FFFFh	C8000h to CFFFFh
SA29	1	1	0	1	0	X	X	X	1A0000h to 1AFFFFh	D0000h to D7FFFh
SA30	1	1	0	1	1	X	X	X	1B0000h to 1BFFFFh	D8000h to DFFFFh
SA31	1	1	1	0	0	X	X	X	1C0000h to 1CFFFFh	E0000h to E7FFFh
SA32	1	1	1	0	1	X	X	X	1D0000h to 1DFFFFh	E8000h to EFFFFh
SA33	1	1	1	1	0	X	X	X	1E0000h to 1EFFFFh	F0000h to F7FFFh
SA34	1	1	1	1	1	X	X	X	1F0000h to 1FFFFFFh	F8000h to FFFFFh

MBM29LV160T-80/-90/-12/MBM29LV160B-80/-90/-12

Common Flash Memory Interface Code Table

Description	A ₆ to A ₀	DQ ₁₅ to DQ ₀	Description	A ₆ to A ₀	DQ ₁₅ to DQ ₀
Query-unique ASCII string "QRY"	10h 11h 12h	0051h 0052h 0059h	Erase Block Region 1 Information bit 15 to bit 0 : y = number of sectors bit 31 to bit 16 : z = size (z×256 bytes)	2Dh 2Eh 2Fh 30h	0000h 0000h 0040h 0000h
Primary OEM Command Set 02h: AMD/FJ standard type	13h 14h	0002h 0000h	Erase Block Region 2 Information bit 15 to bit 0 : y = number of sectors bit 31 to bit 16 : z = size (z×256 bytes)	31h 32h 33h 34h	0001h 0000h 0020h 0000h
Address for Primary Extended Table	15h 16h	0040h 0000h	Erase Block Region 3 Information bit 15 to bit 0 : y = number of sectors bit 31 to bit 16 : z = size (z×256 bytes)	35h 36h 37h 38h	0000h 0000h 0080h 0000h
Alternate OEM Command Set (00h = not applicable)	17h 18h	0000h 0000h	Erase Block Region 4 Information bit 15 to bit 0 : y = number of sectors bit 31 to bit 16 : z = size (z×256 bytes)	39h 3Ah 3Bh 3Ch	001Eh 0000h 0000h 0001h
Address for Alternate OEM Extended Table	19h 1Ah	0000h 0000h	Query-unique ASCII string "PRI"	40h 41h 42h	0050h 0052h 0049h
V _{CC} Min (write/erase) DQ ₇ to DQ ₄ : 1 V DQ ₃ to DQ ₀ : 100 mV	1Bh	0027h	Major version number, ASCII	43h	0031h
V _{CC} Max (write/erase) DQ ₇ to DQ ₄ : 1 V DQ ₃ to DQ ₀ : 100 mV	1Ch	0036h	Minor version number, ASCII	44h	0030h
V _{PP} Min voltage	1Dh	0000h	Address Sensitive Unlock 00h = Required	45h	0000h
V _{PP} Max voltage	1Eh	0000h	Erase Suspend 02h = To Read & Write	46h	0002h
Typical timeout per single byte/word write 2 ^N μs	1Fh	0004h	Sector Protect 00h = Not Supported X = Number of sectors in per group	47h	0001h
Typical timeout for Min size buffer write 2 ^N μs	20h	0000h	Sector Temporary Unprotect 01h = Supported	48h	0001h
Typical timeout per individual sector erase 2 ^N ms	21h	000Ah	Sector Protection Algorithm	49h	0004h
Typical timeout for full chip erase 2 ^N ms	22h	0000h			
Max timeout for byte/word write 2 ^N times typical	23h	0005h			
Max timeout for buffer write 2 ^N times typical	24h	0000h			
Max timeout per individual sector erase 2 ^N times typical	25h	0004h			
Max timeout for full chip erase 2 ^N times typical	26h	0000h			
Device Size = 2 ^N byte	27h	0015h			
Flash Device Interface description 02h : ×8/×16	28h 29h	0002h 0000h			
Max number of bytes in multi-byte write = 2 ^N	2Ah 2Bh	0000h 0000h			
Number of Erase Block Regions within device	2Ch	0004h			

MBM29LV160T-80/-90/-12/MBM29LV160B-80/-90/-12

■ FUNCTIONAL DESCRIPTION

Read Mode

The MBM29LV160T/B has two control functions which must be satisfied in order to obtain data at the outputs. \overline{CE} is the power control and should be used for a device selection. \overline{OE} is the output control and should be used to gate data to the output pins if a device is selected.

Address access time (t_{ACC}) is equal to the delay from stable addresses to valid output data. The chip enable access time (t_{CE}) is the delay from stable addresses and stable \overline{CE} to valid data at the output pins. The output enable access time is the delay from the falling edge of \overline{OE} to valid data at the output pins. (Assuming the addresses have been stable for at least $t_{ACC} - t_{OE}$ time.) See “(1) AC Waveforms for Read Operations” in ■TIMING DIAGRAM for timing specifications.

Standby Mode

There are two ways to implement the standby mode on the MBM29LV160T/B devices. One is by using both the \overline{CE} and \overline{RESET} pins; the other via the \overline{RESET} pin only.

When using both pins, a CMOS standby mode is achieved with \overline{CE} and \overline{RESET} inputs both held at $V_{CC} \pm 0.3$ V. Under this condition the current consumed is less than 5 μ A Max. During Embedded Algorithm operation, V_{CC} Active current (I_{CC2}) is required even $\overline{CE} = "H"$. The device can be read with standard access time (t_{CE}) from either of these standby modes.

When using the \overline{RESET} pin only, a CMOS standby mode is achieved with the \overline{RESET} input held at $V_{SS} \pm 0.3$ V ($\overline{CE} = "H"$ or $"L"$). Under this condition the current consumed is less than 5 μ A Max. Once the \overline{RESET} pin is taken high, the device requires t_{RH} of wake up time before outputs are valid for read access.

In the standby mode, the outputs are in the high-impedance state, independent of the \overline{OE} input.

Automatic Sleep Mode

There is a function called automatic sleep mode to restrain power consumption during read-out of MBM29LV160T/B data. This mode can be used effectively with an application requesting low power consumption such as handy terminals.

To activate this mode, MBM29LV160T/B automatically switches itself to low power mode when addresses remain stable for 150 ns. It is not necessary to control \overline{CE} , \overline{WE} , and \overline{OE} in this mode. During such mode, the current consumed is typically 1 μ A (CMOS Level).

Standard address access timings provide new data when addresses are changed. While in sleep mode, output data is latched and always available to the system.

Output Disable

If the \overline{OE} input is at a logic high level (V_{IH}), output from the device is disabled. This will cause the output pins to be in a high-impedance state.

Autoselect

The Autoselect mode allows the reading out of a binary code from the device and will identify its manufacturer and type. The intent is to allow programming equipment to automatically match the device to be programmed with its corresponding programming algorithm. The Autoselect command may also be used to check the status of write-protected sectors. (See “MBM29LV160T/B Sector Protection Verify Autoselect Code Table” and “Extended Autoselect Code Table” in ■DEVICE BUS OPERATION.) This mode is functional over the entire temperature range of the device.

To activate this mode, the programming equipment must force V_{ID} (11.5 V to 12.5 V) on address pin A_9 . Two identifier bytes may then be sequenced from the devices outputs by toggling address A_0 from V_{IL} to V_{IH} . All addresses are DON'T CARES except A_0 , A_1 , and A_6 (A_{-1}). (See “MBM29LV160T/B User Bus Operation Tables ($\overline{BYTE} = V_{IH}$ or $\overline{BYTE} = V_{IL}$)” in ■DEVICE BUS OPERATION.)

The manufacturer and device codes may also be read via the command register, for instances when the MBM29LV160T/B is erased or programmed in a system without access to high voltage on the A_9 pin. The command sequence is illustrated in “MBM29LV160T/B Standard Command Definitions Table” in ■DEVICE BUS OPERATION.

MBM29LV160T-80/-90/-12/MBM29LV160B-80/-90/-12

Byte 0 ($A_0 = V_{IL}$) represents the manufacture's code and byte 1 ($A_0 = V_{IH}$) represents the device identifier code. For the MBM29LV160T/B these two bytes are given in "Extended Autoselect Code Table" (in ■DEVICE BUS OPERATION). All identifiers for manufactures and device will exhibit odd parity with DQ_7 defined as the parity bit. In order to read the proper device codes when executing the Autoselect, A_1 must be V_{IL} . (See "MBM29LV160T/B User Bus Operation Tables ($\overline{BYTE} = V_{IH}$ and $\overline{BYTE} = V_{IL}$)" in ■DEVICE BUS OPERATION.) For device identification in word mode ($\overline{BYTE} = V_{IH}$), DQ_9 and DQ_{13} are equal to '1' and DQ_{15} , DQ_{14} , DQ_{12} to DQ_{10} and DQ_8 are equal to '0'.

If $\overline{BYTE} = V_{IL}$ (for byte mode), the device code is C4h (for top boot block) or 49h (for bottom boot block).

If $\overline{BYTE} = V_{IH}$ (for word mode), the device code is 22C4h (for top boot block) or 2249h (for bottom boot block).

In order to determine which sectors are write protected, A_1 must be at V_{IH} while running through the sector addresses; if the selected sector is protected, a logical '1' will be output on DQ_0 ($DQ_0 = 1$).

Write

Device erasure and programming are accomplished via the command register. The command register is written by bringing \overline{WE} to V_{IL} , while \overline{CE} is at V_{IL} and \overline{OE} is at V_{IH} . Addresses are latched on the falling edge of \overline{CE} or \overline{WE} , whichever occurs later, while data is latched on the rising edge of \overline{CE} or \overline{WE} pulse, whichever occurs first. Standard microprocessor write timings are used. See "(3) AC Waveforms for Alternate \overline{WE} Controlled Program Operations" and "(4) AC Waveforms for Alternate \overline{CE} Controlled Program Operations" and "(5) AC Waveforms for Chip/Sector Erase Operations" in ■TIMING DIAGRAM.

Refer to AC Write Characteristics and the Erase/Programming Waveforms for specific timing parameters.

Sector Protection

The MBM29LV160T/B features hardware sector protection. This feature will disable both program and erase operations in any number of sectors (0 through 34). The sector protection feature is enabled using programming equipment at the user's site. The device is shipped with all sectors unprotected.

To activate this mode, the programming equipment must force V_{ID} on address pin A_9 and control pin \overline{OE} , $\overline{CE} = V_{IL}$, $A_0 = A_6 = V_{IL}$, $A_1 = V_{IH}$. The sector addresses pins (A_{19} , A_{18} , A_{17} , A_{16} , A_{15} , A_{14} , A_{13} , and A_{12}) should be set to the sector to be protected. "Sector Address Tables (MBM29LV160T/B)" in ■FLEXIBLE SECTOR-ERASE ARCHITECTURE define the sector address for each of the thirty five (35) individual sectors. Programming of the protection circuitry begins on the falling edge of the \overline{WE} pulse and is terminated with the rising edge of the same. Sector addresses must be held constant during the \overline{WE} pulse. See "(13) AC Waveforms for Sector Protection Timing Diagram" in ■TIMING DIAGRAM and "(5) Sector Protection Algorithm" in ■FLOW CHART for sector protection waveforms and algorithm.

To verify programming of the protection circuitry, the programming equipment must force V_{ID} on address pin A_9 with \overline{CE} and \overline{OE} at V_{IL} and \overline{WE} at V_{IH} . Scanning the sector addresses (A_{19} , A_{18} , A_{17} , A_{16} , A_{15} , A_{14} , A_{13} , and A_{12}) while (A_6, A_1, A_0) = (0, 1, 0) will produce a logical "1" at device output DQ_0 for a protected sector. Otherwise the device will read 00h for an unprotected sector. In this mode, the lower order addresses, except for A_0 , A_1 , and A_6 are DON'T CARES. Address locations with $A_1 = V_{IL}$ are reserved for Autoselect manufacturer and device codes. A_{-1} requires to V_{IL} in byte mode.

It is also possible to determine if a sector is protected in the system by writing an Autoselect command. Performing a read operation at the address location XX02h, where the higher order addresses pins (A_{19} , A_{18} , A_{17} , A_{16} , A_{15} , A_{14} , A_{13} , and A_{12}) represents the sector address will produce a logical "1" at DQ_0 for a protected sector. See "MBM29LV160T/B Sector Protection Verify Autoselect Code Table" and "Extended Autoselect Code Table" in ■DEVICE BUS OPERATION for Autoselect codes.

Temporary Sector Unprotection

This feature allows temporary unprotection of previously protected sectors of the MBM29LV160T/B devices in order to change data. The Sector Unprotection mode is activated by setting the \overline{RESET} pin to high voltage (12 V). During this mode, formerly protected sectors can be programmed or erased by selecting the sector addresses. Once the 12 V is taken away from the \overline{RESET} pin, all the previously protected sectors will be protected again. (See "(15) Temporary Sector Unprotection Timing Diagram" in ■TIMING DIAGRAM and "(6) Temporary Sector Unprotection Algorithm" in ■FLOW CHART.)

MBM29LV160T-80/-90/-12/MBM29LV160B-80/-90/-12

■ COMMAND DEFINITIONS

Device operations are selected by writing specific address and data sequences into the command register. Writing incorrect address and data values or writing them in an improper sequence will reset the device to the read mode. “MBM29LV160T/B Standard Command Definitions” in ■DEVICE BUS OPERATION defines the valid register command sequences. Note that the Erase Suspend (B0h) and Erase Resume (30h) commands are valid only while the Sector Erase operation is in progress. Moreover both Read/Reset commands are functionally equivalent, resetting the device to the read mode. Please note that commands are always written at DQ₇ to DQ₀ and DQ₁₅ to DQ₈ bits are ignored.

Read/Reset Command

In order to return from Autoselect mode or Exceeded Timing Limits (DQ₅ = 1) to read mode, the read/reset operation is initiated by writing the Read/Reset command sequence into the command register. Microprocessor read cycles retrieve array data from the memory. The device remains enabled for reads until the command register contents are altered.

The device will automatically power-up in the Read/Reset state. In this case, a command sequence is not required to read data. Standard microprocessor read cycles will retrieve array data. This default value ensures that no spurious alteration of the memory contents occurs during the power transition. Refer to the AC Read Characteristics and Waveforms for specific timing parameters. (See “(1) AC Waveforms for Read Operations” in ■TIMING DIAGRAM.)

Autoselect Command

Flash memories are intended for use in applications where the local CPU alters memory contents. As such, manufactures and device codes must be accessible while the device resides in the target system. PROM programmers typically access the signature codes by raising A₉ to a high voltage. However, multiplexing high voltage onto the address lines is not generally desired system design practice.

The device contains an Autoselect command operation to supplement traditional PROM programming methodology. The operation is initiated by writing the Autoselect command sequence into the command register. Following the last command write, a read cycle from address XX00h retrieves the manufacture code of 04h. A read cycle from address XX01h for ×16 (XX02h for ×8) retrieves the device code (MBM29LV160T = C4h and MBM29LV160B = 49h for ×8 mode; MBM29LV160T = 22C4h and MBM29LV160B = 2249h for ×16 mode). (See “MBM29LV160T/B Sector Protection Verify Autoselect Code Table” and “Extended Autoselect Code Table” in ■DEVICE BUS OPERATION.)

All manufactures and device codes will exhibit odd parity with DQ₇ defined as the parity bit.

The sector state (protection or unprotection) will be indicated by address XX02h for ×16 (XX04h for ×8).

Scanning the sector addresses (A₁₉, A₁₈, A₁₇, A₁₆, A₁₅, A₁₄, A₁₃, and A₁₂) while (A₆, A₁, A₀) = (0, 1, 0) will produce a logical “1” at device output DQ₀ for a protected sector. The programming verification should be performed margin mode verification on the protected sector. (See “MBM29LV160T/B User Bus Operation Tables (BYT_E = V_{IH} and BYT_E = V_{IL})” in ■DEVICE BUS OPERATION.)

To terminate the operation, it is necessary to write the Read/Reset command sequence into the register and, also to write the Autoselect command during the operation, by executing it after writing the Read/Reset command sequence.

Word/Byte Programming

The device is programmed on a byte-by-byte (or word-by-word) basis. Programming is a four bus cycle operation. There are two “unlock” write cycles. These are followed by the program set-up command and data write cycles. Addresses are latched on the falling edge of CE or WE, whichever happens later and the data is latched on the rising edge of CE or WE, whichever happens first. The rising edge of the last CE or WE (whichever happens first) begins programming. Upon executing the Embedded Program Algorithm command sequence, the system is not required to provide further controls or timings. The device will automatically provide adequate internally generated program pulses and verify the programmed cell margin. (See “(3) AC Waveforms for Alternate WE Controlled Program Operations” and “(4) AC Waveforms for Alternate CE Controlled Program Operations” in ■TIMING DIAGRAM.)

MBM29LV160T-80/-90/-12/MBM29LV160B-80/-90/-12

The automatic programming operation is completed when the data on DQ₇ is equivalent to data written to this bit at which time the device return to the read mode and addresses are no longer latched. (See “Hardware Sequence Flags Table”.) Therefore, the device requires that a valid address be supplied by the system at this time. Hence, Data Polling must be performed at the memory location which is being programmed.

Any commands written to the chip during this period will be ignored. If hardware reset occurs during the programming operation, it is impossible to guarantee whether the data being written is correct or not.

Programming is allowed in any sequence and across sector boundaries. Beware that a data “0” cannot be programmed back to a “1”. Attempting to do so may either hang up the device or result in an apparent success according to the data polling algorithm but a read from read/reset mode will show that the data is still “0”. Only erase operations can convert “0”s to “1”s.

“(1) Embedded Program™ Algorithm” in ■FLOW CHART illustrates the Embedded Program™ Algorithm using typical command strings and bus operations.

Chip Erase

Chip erase is a six-bus cycle operation. There are two “unlock” write cycles. These are followed by writing the “set-up” command. Two more “unlock” write cycles are then followed by the chip erase command.

Chip erase does not require the user to program the device prior to erase. Upon executing the Embedded Erase Algorithm command sequence the device will automatically program and verify the entire memory for an all zero data pattern prior to electrical erase. (Preprogram Function.) The system is not required to provide any controls or timings during these operations.

The automatic erase begins on the rising edge of the last \overline{WE} pulse in the command sequence and terminates when the data on DQ₇ is “1” (See Write Operation Status section.) at which time the device returns to read mode. (See “(5) AC Waveforms for Chip/Sector Erase Operations” in ■TIMING DIAGRAM.)

“(2) Embedded Erase™ Algorithm” in ■FLOW CHART illustrates the Embedded Erase™ Algorithm using typical command strings and bus operations.

Sector Erase

Sector erase is a six-bus cycle operation. There are two “unlock” write cycles, followed by writing the “set-up” command. Two more “unlock” write cycles are then followed by the Sector Erase command. The sector address (any address location within the desired sector) is latched on the falling edge of \overline{WE} , while the command (Data = 30h) is latched on the rising edge of \overline{WE} . After a time-out of 50 μ s from the rising edge of the last sector erase command, the sector erase operation will begin.

Multiple sectors may be erased concurrently by writing six-bus cycle operations on “MBM29LV160T/B Standard Command Definitions” in ■DEVICE BUS OPERATION. This sequence is followed with writes of the Sector Erase command to addresses in other sectors desired to be concurrently erased. The time between writes must be less than 50 μ s otherwise that command will not be accepted and erasure will start. It is recommended that processor interrupts be disabled during this time to guarantee this condition. The interrupts can be re-enabled after the last Sector Erase command is written. A time-out of 50 μ s from the rising edge of the last \overline{WE} will initiate the execution of the Sector Erase command(s). If another falling edge of the \overline{WE} occurs within the 50 μ s time-out window the timer is reset. Monitor DQ₃ to determine if the sector erase timer window is still open. (See section DQ₃, Sector Erase Timer.) Any command other than Sector Erase or Erase Suspend during this time-out period will reset the device to the read mode, ignoring the previous command string. Resetting the device once execution has begun will corrupt the data in the sector. In that case, restart the erase on those sectors and allow them to complete. (Refer to the Write Operation Status section for Sector Erase Timer operation.) Loading the sector erase buffer may be done in any sequence and with any number of sectors (0 to 34).

Sector erase does not require the user to program the device prior to erase. The device automatically programs all memory locations in the sector(s) to be erased prior to electrical erase (Preprogram Function). When erasing a sector or sectors the remaining unselected sectors are not affected. The system is not required to provide any controls or timings during these operations. (See “(5) AC Waveforms for Chip/Sector Erase Operations” in ■TIMING DIAGRAM.)

MBM29LV160T-80/-90/-12/MBM29LV160B-80/-90/-12

The automatic sector erase begins after the 50 μ s time out from the rising edge of the \overline{WE} pulse for the last sector erase command pulse and terminates when the data on DQ₇ is “1” (See Write Operation Status section) at which time the device returns to the read mode. Data polling must be performed at an address within any of the sectors being erased. Multiple Sector Erase Time; [Sector Program Time (Preprogramming) + Sector Erase Time] \times Number of Sector Erase.

“(2) Embedded Erase™ Algorithm” in ■FLOW CHART illustrates the Embedded Erase™ Algorithm using typical command strings and bus operations.

Erase Suspend/Resume

The Erase Suspend command allows the user to interrupt a Sector Erase operation and then perform data reads from or program to a sector not being erased. This command is applicable ONLY during the Sector Erase operation which includes the time-out period for sector erase. The Erase Suspend command will be ignored if written during the Chip Erase operation or Embedded Program Algorithm. Writing the Erase Suspend command during the Sector Erase time-out results in immediate termination of the time-out period and suspension of the erase operation.

Writing the Erase Resume command resumes the erase operation. The addresses are “DON’T CARES” when writing the Erase Suspend or Erase Resume commands.

When the Erase Suspend command is written during the Sector Erase operation, the device will take a maximum of 20 μ s to suspend the erase operation. When the devices have entered the erase-suspended mode, the RY/ \overline{BY} output pin and the DQ₇ bit will be at logic “1”, and DQ₆ will stop toggling. The user must use the address of the erasing sector for reading DQ₆ and DQ₇ to determine if the erase operation has been suspended. Further writes of the Erase Suspend command are ignored.

When the erase operation has been suspended, the device defaults to the erase-suspend-read mode. Reading data in this mode is the same as reading from the standard read mode except that the data must be read from sectors that have not been erase-suspended. Successively reading from the erase-suspended sector while the device is in the erase-suspend-read mode will cause DQ₂ to toggle. (See the section on DQ₂.)

After entering the erase-suspend-read mode, the user can program the device by writing the appropriate command sequence for Program. This Program mode is known as the erase-suspend-program mode. Again, programming in this mode is the same as programming in the regular Program mode except that the data must be programmed to sectors that are not erase-suspended. Successively reading from the erase-suspended sector while the devices are in the erase-suspend-program mode will cause DQ₂ to toggle. The end of the erase-suspended Program operation is detected by the RY/ \overline{BY} output pin, Data polling of DQ₇, or the Toggle Bit (DQ₆) which is the same as the regular Program operation. Note that DQ₇ must be read from the Program address while DQ₆ can be read from any address.

To resume the operation of Sector Erase, the Resume command (30h) should be written. Any further writes of the Resume command at this point will be ignored. Another Erase Suspend command can be written after the chip has resumed erasing.

Extended Command

(1) Fast Mode

MBM29LV160T/B has Fast Mode function. This mode dispenses with the initial two unlock cycles required in the standard program command sequence writing Fast Mode command into the command register. In this mode, the required bus cycle for programming is two cycles instead of four bus cycles in standard program command. The read operation is also executed after exiting this mode. During the Fast mode, do not write any command other than the Fast program/Fast mode reset command. To exit this mode, it is necessary to write Fast Mode Reset command into the command register. (Refer to “(7) Embedded Programming Algorithm for Fast Mode” in ■FLOW CHART.) The V_{CC} active current is required even $\overline{CE} = V_{IH}$ during Fast Mode.

(2) Fast Programming

During Fast Mode, the programming can be executed with two bus cycles operation. The Embedded Program Algorithm is executed by writing program set-up command (A0h) and data write cycles (PA/PD). (Refer to “(7) Embedded Programming Algorithm for Fast Mode” in ■FLOW CHART.)

MBM29LV160T-80/-90/-12/MBM29LV160B-80/-90/-12

(3) CFI (Common Flash Memory Interface)

The CFI (Common Flash Memory Interface) specification outlines device and host system software interrogation handshake which allows specific vendor-specified software algorithms to be used for entire families of devices. This allows device-independent, JEDEC ID-independent, and forward-and backward-compatible software support for the specified flash device families. Refer to CFI specification in detail.

The operation is initiated by writing the query command (98h) into the command register. Following the command write, a read cycle from specific address retrieves device information. Please note that output data of upper byte (DQ₁₅ to DQ₈) is "0" in word mode (16 bit) read. Refer to "Common Flash Memory Interface Code Table" in ■ FLEXIBLE SECTOR-ERASE ARCHITECTURE. To terminate operation, it is necessary to write the read/reset command sequence into the register.

(4) Extended Sector Protect

In addition to normal sector protection, the MBM29LV160T/B has Extended Sector Protection as extended function. This function enable to protect sector by forcing V_{ID} on $\overline{\text{RESET}}$ pin and write a commnad sequence. Unlike conventional procedure, it is not necessary to force V_{ID} and control timing for control pins. The only $\overline{\text{RESET}}$ pin requires V_{ID} for sector protection in this mode. The extended sector protect requires V_{ID} on $\overline{\text{RESET}}$ pin. With this condition, the operation is initiated by writing the set-up command (60h) into the command register. Then, the sector addresses pins (A₁₉, A₁₈, A₁₇, A₁₆, A₁₅, A₁₄, A₁₃ and A₁₂) and (A₆, A₁, A₀) = (0, 1, 0) should be set to the sector to be protected (recommend to set V_{IL} for the other addresses pins), and write extended sector protect command (60h). A sector is typically protected in 150 μs. To verify programming of the protection circuitry, the sector addresses pins (A₁₉, A₁₈, A₁₇, A₁₆, A₁₅, A₁₄, A₁₃ and A₁₂) and (A₆, A₁, A₀) = (0, 1, 0) should be set and write a command (40h). Following the command write, a logical "1" at device output DQ₀ will produce for protected sector in the read operation. If the output data is logical "0", please repeat to write extended sector protect command (60h) again. To terminate the operation, it is necessary to set $\overline{\text{RESET}}$ pin to V_{IH}.

Write Operation Status

Hardware Sequence Flags Table

Status		DQ ₇	DQ ₆	DQ ₅	DQ ₃	DQ ₂	
In Progress	Embedded Program Algorithm	$\overline{\text{DQ}}_7$	Toggle	0	0	1	
	Embedded/Erase Algorithm	0	Toggle	0	1	Toggle	
	Erase Suspend Mode	Erase Suspend Read (Erase Suspended Sector)	1	1	0	0	Toggle
		Erase Suspend Read (Non-Erase Suspended Sector)	Data	Data	Data	Data	Data
	Erase Suspend Program (Non-Erase Suspended Sector)	$\overline{\text{DQ}}_7$	Toggle* ¹	0	0	1* ²	
Exceeded Time Limits	Embedded Program Algorithm	$\overline{\text{DQ}}_7$	Toggle	1	0	1	
	Embedded/Erase Algorithm	0	Toggle	1	1	N/A	
	Erase Suspend Program (Non-Erase Suspended Sector)	$\overline{\text{DQ}}_7$	Toggle	1	0	N/A	

*1 : Performing successive read operations from any address will cause DQ₆ to toggle.

*2 : Reading the byte address being programmed while in the erase-suspend program mode will indicate logic "1" at the DQ₂ bit. However, successive reads from the erase-suspended sector will cause DQ₂ to toggle.

Notes : • DQ₀ and DQ₁ are reserve pins for future use.
• DQ₄ is Fujitsu internal use only.

MBM29LV160T-80/-90/-12/MBM29LV160B-80/-90/-12

DQ₇

Data Polling

The MBM29LV160T/B device features $\overline{\text{Data}}$ Polling as a method to indicate to the host that the Embedded Algorithms are in progress or completed. During the Embedded Program Algorithm, an attempt to read the devices will produce the complement of the data last written to DQ₇. Upon completion of the Embedded Program Algorithm, an attempt to read the device will produce the true data last written to DQ₇. During the Embedded Erase Algorithm, an attempt to read the device will produce a “0” at the DQ₇ output. Upon completion of the Embedded Erase Algorithm an attempt to read the device will produce a “1” at the DQ₇ output. The flowchart for $\overline{\text{Data}}$ Polling (DQ₇) is shown in “(3) $\overline{\text{Data}}$ Polling Algorithm” in ■FLOW CHART.

For chip erase and sector erase, $\overline{\text{Data}}$ Polling is valid after the rising edge of the sixth $\overline{\text{WE}}$ pulse in the six-write pulse sequence. $\overline{\text{Data}}$ Polling must be performed at a sector address within any of the sectors being erased and not at a protected sector. Otherwise, the status may not be valid. Once the Embedded Algorithm operation is close to being completed, the MBM29LV160T/B data pins (DQ₇) may change asynchronously while the output enable ($\overline{\text{OE}}$) is asserted low. This means that the device is driving status information on DQ₇ at one instant of time and then that byte's valid data at the next instant of time. Depending on when the system samples the DQ₇ output, it may read the status or valid data. Even if the device has completed the Embedded Program Algorithm operation and DQ₇ has a valid data, the data outputs on DQ₆ to DQ₀ may be still invalid. The valid data on DQ₇ to DQ₀ will be read on successive read attempts.

The $\overline{\text{Data}}$ Polling feature is only active during the Embedded Programming Algorithm, Embedded Erase Algorithm or sector erase time-out.

See “(6) AC Waveforms for $\overline{\text{Data}}$ Polling during Embedded Algorithm Operations” in ■TIMING DIAGRAM for the $\overline{\text{Data}}$ Polling timing specifications and diagrams.

DQ₆

Toggle Bit I

The MBM29LV160T/B also feature the “Toggle Bit I” as a method to indicate to the host system that the Embedded Algorithms are in progress or completed.

During an Embedded Program or Erase Algorithm cycle, successive attempts to read ($\overline{\text{OE}}$ toggling) data from the device will result in DQ₆ toggling between one and zero. Once the Embedded Program or Erase Algorithm cycle is completed, DQ₆ will stop toggling and valid data can be read on the next successive attempts. During programming, the Toggle Bit I is valid after the rising edge of the fourth $\overline{\text{WE}}$ pulse in the four write pulse sequence. For chip erase and sector erase, the Toggle Bit I is valid after the rising edge of the sixth $\overline{\text{WE}}$ pulse in the six-write pulse sequence. The Toggle Bit I is active during the sector time out.

In programming, if the sector being written to is protected, the toggle bit will toggle for about 2 μs and then stop toggling without the data having changed. In erase, the device will erase all the selected sectors except for the ones that are protected. If all selected sectors are protected, the chip will toggle the Toggle Bit I for about 200 μs and then drop back into read mode, having changed none of the data.

Either $\overline{\text{CE}}$ or $\overline{\text{OE}}$ toggling will cause the DQ₆ to toggle. In addition, an Erase Suspend/Resume command will cause the DQ₆ to toggle.

See “(7) AC Waveforms for Toggle Bit I during Embedded Algorithm Operations” in ■TIMING DIAGRAM and “(4) Toggle Bit Algorithm” in ■FLOW CHART for the Toggle Bit I timing specifications and diagrams.

DQ₅

Exceeded Timing Limits

DQ₅ will indicate if the program or erase time has exceeded the specified limits (internal pulse count). Under these conditions DQ₅ will produce a “1”. This is a failure condition which indicates that the program or erase cycle was not successfully completed. $\overline{\text{Data}}$ Polling is the only operating function of the device under this condition. The $\overline{\text{CE}}$ circuit will partially power down the device under these conditions. The $\overline{\text{OE}}$ and $\overline{\text{WE}}$ pins will control the output disable functions as described in “MBM29LV160T/B User Bus Operation Tables (BYTE = V_{IH} and BYTE = V_{IL})” (in ■DEVICE BUS OPERATION).

MBM29LV160T-80/-90/-12/MBM29LV160B-80/-90/-12

The DQ₅ failure condition may also appear if a user tries to program a non blank location without erasing. In this case the device locks out and never completes the Embedded Algorithm operation. Hence, the system never reads a valid data on DQ₇ and DQ₆ never stops toggling. Once the device has exceeded timing limits, the DQ₅ bit will indicate a “1.” Please note that this is not a device failure condition since the device was incorrectly used. If this occurs, reset the device with command sequence.

DQ₃

Sector Erase Timer

After the completion of the initial sector erase command sequence the sector erase time-out will begin. DQ₃ will remain low until the time-out is complete. $\overline{\text{Data}}$ Polling and Toggle Bit I are valid after the initial sector erase command sequence.

If $\overline{\text{Data}}$ Polling or the Toggle Bit I indicates the device has been written with a valid erase command, DQ₃ may be used to determine if the sector erase timer window is still open. If DQ₃ is high (“1”) the internally controlled erase cycle has begun; attempts to write subsequent commands to the device will be ignored until the erase operation is completed as indicated by $\overline{\text{Data}}$ Polling or Toggle Bit I. If DQ₃ is low (“0”), the device will accept additional sector erase commands. To insure the command has been accepted, the system software should check the status of DQ₃ prior to and following each subsequent sector erase command. If DQ₃ is high on the second status check, the command may not have been accepted.

See “Hardware Sequence Flags Table”.

DQ₂

Toggle Bit II

This Toggle Bit II, along with DQ₆, can be used to determine whether the device is in the Embedded Erase Algorithm or in Erase Suspend.

Successive reads from the erasing sector will cause DQ₂ to toggle during the Embedded Erase Algorithm. If the device is in the erase-suspended-read mode, successive reads from the erase-suspended sector will cause DQ₂ to toggle. When the device is in the erase-suspended-program mode, successive reads from the byte address of the non-erase suspended sector will indicate a logic “1” at DQ₂.

DQ₆ is different from DQ₂ in that DQ₆ toggles only when the standard program or Erase, or Erase Suspend Program operation is in progress.

For example, DQ₂ and DQ₆ can be used together to determine if the erase-suspend-read mode is in progress. (DQ₂ toggles while DQ₆ does not.) See also “Toggle Bit Status Table” and “(16) DQ₂ vs. DQ₆” in ■TIMING DIAGRAM.

Furthermore, DQ₂ can also be used to determine which sector is being erased. When the device is in the erase mode, DQ₂ toggles if this bit is read from an erasing sector.

Toggle Bit Status Table

Mode	DQ ₇	DQ ₆	DQ ₂
Program	$\overline{\text{DQ}}_7$	Toggle	1
Erase	0	Toggle	Toggle
Erase Suspend Read (Erase Suspended Sector)*1	1	1	Toggle
Erase-Suspend Program	$\overline{\text{DQ}}_7$	Toggle*1	1 *2

*1 : Performing successive read operations from any address will cause DQ₆ to toggle.

*2 : Reading the byte address being programmed while in the erase-suspend program mode will indicate logic “1” at the DQ₂ bit. However, successive reads from the erase-suspended sector will cause DQ₂ to toggle.

MBM29LV160T-80/-90/-12/MBM29LV160B-80/-90/-12

RY/ $\overline{\text{BY}}$

Ready/Busy Pin

The MBM29LV160T/B provides a RY/ $\overline{\text{BY}}$ open-drain output pin as a way to indicate to the host system that the Embedded Algorithms are either in progress or has been completed. If the output is low, the device is busy with either a program or erase operation. If the output is high, the device is ready to accept any read/write or erase operation. When the RY/ $\overline{\text{BY}}$ pin is low, the devices will not accept any additional program or erase commands with the exception of the Erase Suspend command. If the MBM29LV160T/B is placed in an Erase Suspend mode, the RY/ $\overline{\text{BY}}$ output will be high, by means of connecting with a pull-up resistor to V_{CC} .

During programming, the RY/ $\overline{\text{BY}}$ pin is driven low after the rising edge of the fourth $\overline{\text{WE}}$ pulse. During an erase operation, the RY/ $\overline{\text{BY}}$ pin is driven low after the rising edge of the sixth $\overline{\text{WE}}$ pulse. The RY/ $\overline{\text{BY}}$ pin will indicate a busy condition during the $\overline{\text{RESET}}$ pulse. See “(8) RY/ $\overline{\text{BY}}$ Timing Diagram during Program/Erase Operations” and “(9) $\overline{\text{RESET}}$, RY/ $\overline{\text{BY}}$ Timing Diagram” in ■TIMING DIAGRAM for a detailed timing diagram. The RY/ $\overline{\text{BY}}$ pin is pulled high in standby mode.

Since this is an open-drain output, the pull-up resistor needs to be connected to V_{CC} ; multiples of devices may be connected to the host system via more than one RY/ $\overline{\text{BY}}$ pin in parallel.

RESET

Hardware Reset Pin

The MBM29LV160T/B device may be reset by driving the $\overline{\text{RESET}}$ pin to V_{IL} . The $\overline{\text{RESET}}$ pin has a pulse requirement and has to be kept low (V_{IL}) for at least 500 ns in order to properly reset the internal state machine. Any operation in the process of being executed will be terminated and the internal state machine will be reset to the read mode t_{READY} after the $\overline{\text{RESET}}$ pin is driven low. Furthermore, once the $\overline{\text{RESET}}$ pin goes high, the device requires an additional t_{RH} before it allows read access. When the $\overline{\text{RESET}}$ pin is low, the device will be in the standby mode for the duration of the pulse and all the data output pins will be tri-stated. If a hardware reset occurs during a program or erase operation, the data at that particular location will be corrupted. Please note that the RY/ $\overline{\text{BY}}$ output signal should be ignored during the $\overline{\text{RESET}}$ pulse. Refer to “(9) $\overline{\text{RESET}}$, RY/ $\overline{\text{BY}}$ Timing Diagram” in ■TIMING DIAGRAM for the timing diagram. Refer to Temporary Sector Unprotection for additional functionality.

If hardware reset occurs during Embedded Erase Algorithm, there is a possibility that the erasing sector(s) will need to be erased again before they can be programmed.

Word/Byte Configuration

The $\overline{\text{BYTE}}$ pin selects the byte (8-bit) mode or word (16-bit) mode for the MBM29LV160T/B device. When this pin is driven high, the device operates in the word (16-bit) mode. The data is read and programmed at DQ_{15} to DQ_0 . When this pin is driven low, the device operates in byte (8-bit) mode. Under this mode, $\text{DQ}_{15}/\text{A}_{-1}$ pin becomes the lowest address bit and DQ_{14} to DQ_8 bits are tri-stated. However, the command bus cycle is always an 8-bit operation and hence commands are written at DQ_7 to DQ_0 and DQ_{15} to DQ_8 bits are ignored. Refer to “(10) Timing Diagram for Word Mode Configuration” and “(11) Timing Diagram for Byte Mode Configuration” in ■TIMING DIAGRAM for the timing diagrams.

Data Protection

The MBM29LV160T/B is designed to offer protection against accidental erasure or programming caused by spurious system level signals that may exist during power transitions. During power up the device automatically resets the internal state machine to the Read mode. Also, with its control register architecture, alteration of the memory contents only occurs after successful completion of specific multi-bus cycle command sequence.

The device also incorporates several features to prevent inadvertent write cycles resulting from V_{CC} power-up and power-down transitions or system noise.

Low V_{CC} Write Inhibit

To avoid initiation of a write cycle during V_{CC} power-up and power-down, a write cycle is locked out for V_{CC} less than 2.3 V (typically 2.4 V). If $V_{CC} < V_{LKO}$, the command register is disabled and all internal program/erase circuits are disabled. Under this condition, the device will reset to the read mode. Subsequent writes will be ignored until

MBM29LV160T-80/-90/-12/MBM29LV160B-80/-90/-12

the V_{CC} level is greater than V_{LKO} . It is the users responsibility to ensure that the control pins are logically correct to prevent unintentional writes when V_{CC} is above 2.3 V.

If the Embedded Erase Algorithm is interrupted, there is possibility that the erasing sector(s) will need to be erased again prior to programming.

Write Pulse “Glitch” Protection

Noise pulses of less than 3 ns (typical) on \overline{OE} , \overline{CE} , or \overline{WE} will not change the command registers.

Logical Inhibit

Writing is inhibited by holding any one of $\overline{OE} = V_{IL}$, $\overline{CE} = V_{IH}$, or $\overline{WE} = V_{IH}$. To initiate a write, \overline{CE} and \overline{WE} must be a logical zero while \overline{OE} is a logical one.

Power-up Write Inhibit

Power-up of the devices with $\overline{WE} = \overline{CE} = V_{IL}$ and $\overline{OE} = V_{IH}$ will not accept commands on the rising edge of \overline{WE} . The internal state machine is automatically reset to read mode on power-up.

Sector Protection

Device user is able to protect each sector individually to store and protect data. Protection circuit voids both program and erase commands that are addressed to protect sectors.

Any command to program or erase addressed to protected sector are ignored (see “Sector Protection” in ■FUNCTIONAL DESCRIPTION).

MBM29LV160T-80/-90/-12/MBM29LV160B-80/-90/-12

■ ABSOLUTE MAXIMUM RATINGS

Parameter	Symbol	Rating		Unit
		Min	Max	
Storage Temperature	T _{stg}	-55	+125	°C
Ambient Temperature with Power Applied	T _A	-40	+85	°C
Voltage with Respect to Ground All pins except A ₉ , \overline{OE} , \overline{RESET} *1, *2	V _{IN} , V _{OUT}	-0.5	V _{CC} +0.5	V
A ₉ , \overline{OE} and \overline{RESET} *1, *3	V _{IN}	-2.0	+13.0	V
Power Supply Voltage*1	V _{CC}	-0.5	+5.5	V

*1: Voltage is defined on the basis of V_{SS} = GND = 0 V.

*2: Minimum DC voltage on input or I/O pins is -0.5 V. During voltage transitions, input or I/O pins may undershoot V_{SS} to -2.0 V for periods of up to 20 ns. Maximum DC voltage on input or I/O pins is V_{CC} +0.5 V. During voltage transitions, input or I/O pins may overshoot to V_{CC} +2.0 V for periods of up to 20 ns.

*3: Minimum DC input voltage on A₉, \overline{OE} , and \overline{RESET} pins is -0.5 V. During voltage transitions, A₉, \overline{OE} , and \overline{RESET} pins may undershoot V_{SS} to -2.0 V for periods of up to 20 ns. Voltage difference between input and supply voltage (V_{IN} - V_{CC}) does not exceed +9.0 V. Maximum DC input voltage on A₉, \overline{OE} , and \overline{RESET} pins are +13.0 V which may overshoot to +14.0 V for periods of up to 20 ns.

WARNING: Semiconductor devices can be permanently damaged by application of stress (voltage, current, temperature, etc.) in excess of absolute maximum ratings. Do not exceed these ratings.

■ RECOMMENDED OPERATING CONDITIONS

Parameter	Symbol	Part number	Value		Unit
			Min	Max	
Ambient Temperature	T _A	MBM29LV160T/B-80	-20	+70	°C
		MBM29LV160T/B-90/-12	-40	+85	°C
Power Supply Voltage*	V _{CC}	MBM29LV160T/B-80	+3.0	+3.6	V
		MBM29LV160T/B-90/-12	+2.7		

* : Voltage is defined on the basis of V_{SS} = GND = 0 V.

Note : Operating ranges define those limits between which the functionality of the devices are guaranteed.

WARNING: The recommended operating conditions are required in order to ensure the normal operation of the semiconductor device. All of the device's electrical characteristics are warranted when the device is operated within these ranges.

Always use semiconductor devices within their recommended operating condition ranges. Operation outside these ranges may adversely affect reliability and could result in device failure.

No warranty is made with respect to uses, operating conditions, or combinations not represented on the data sheet. Users considering application outside the listed conditions are advised to contact their FUJITSU representatives beforehand.

MBM29LV160T-80/-90/-12/MBM29LV160B-80/-90/-12

■ MAXIMUM OVERSHOOT/MAXIMUM UNDERSHOOT

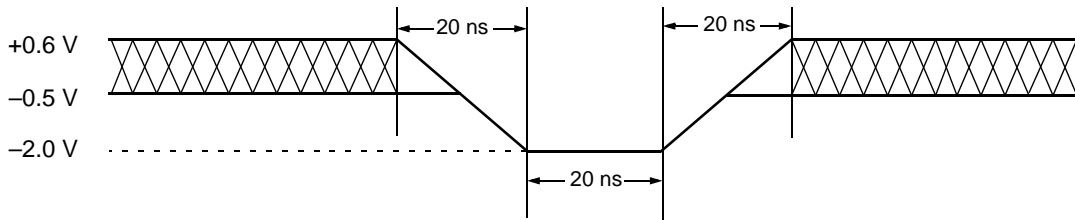

Maximum Undershoot Waveform

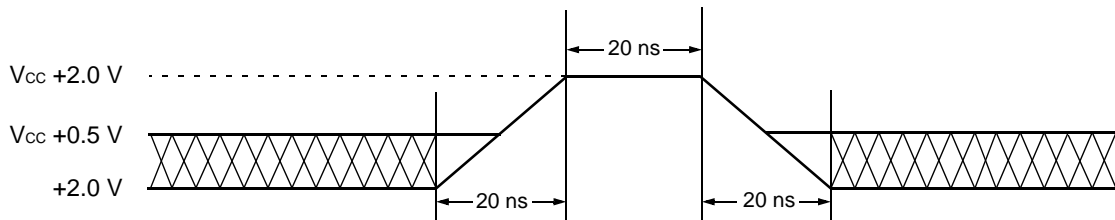

Maximum Overshoot Waveform 1

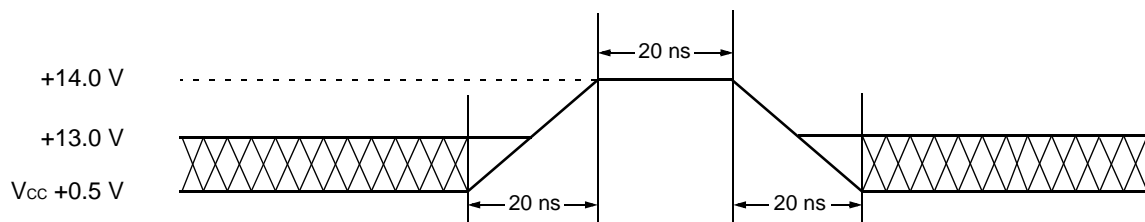

Note : This waveform is applied for A_9 , \overline{OE} , and \overline{RESET} .

Maximum Overshoot Waveform 2

MBM29LV160T-80/-90/-12/MBM29LV160B-80/-90/-12

■ DC CHARACTERISTICS

Parameter	Symbol	Test Conditions	Min	Max	Unit	
Input Leakage Current	I_{LI}	$V_{IN} = V_{SS}$ to V_{CC} , $V_{CC} = V_{CC}$ Max	-1.0	+1.0	μA	
Output Leakage Current	I_{LO}	$V_{OUT} = V_{SS}$ to V_{CC} , $V_{CC} = V_{CC}$ Max	-1.0	+1.0	μA	
A_9 , \overline{OE} , \overline{RESET} Inputs Leakage Current	I_{LIT}	$V_{CC} = V_{CC}$ Max, A_9 , \overline{OE} , $\overline{RESET} = 12.5$ V	—	35	μA	
V _{CC} Active Current *1	I_{CC1}	$\overline{CE} = V_{IL}$, $\overline{OE} = V_{IH}$, f = 10 MHz	Byte	—	30	mA
			Word	—	35	
		$\overline{CE} = V_{IL}$, $\overline{OE} = V_{IH}$, f = 5 MHz	Byte	—	15	mA
			Word	—	17	
V _{CC} Active Current *2	I_{CC2}	$\overline{CE} = V_{IL}$, $\overline{OE} = V_{IH}$	—	35	mA	
V _{CC} Current (Standby)	I_{CC3}	$V_{CC} = V_{CC}$ Max, $\overline{CE} = V_{CC} \pm 0.3$ V, $\overline{RESET} = V_{CC} \pm 0.3$ V	—	5	μA	
V _{CC} Current (Standby, \overline{RESET})	I_{CC4}	$V_{CC} = V_{CC}$ Max, $\overline{RESET} = V_{SS} \pm 0.3$ V	—	5	μA	
V _{CC} Current (Automatic Sleep Mode) *3	I_{CC5}	$V_{CC} = V_{CC}$ Max, $\overline{CE} = V_{SS} \pm 0.3$ V, $\overline{RESET} = V_{CC} \pm 0.3$ V, $V_{IN} = V_{CC} \pm 0.3$ V or $V_{SS} \pm 0.3$ V	—	5	μA	
Input Low Voltage	V_{IL}	—	-0.5	0.6	V	
Input High Voltage	V_{IH}	—	2.0	$V_{CC} + 0.3$	V	
Voltage for Autoselect, Sector Protection, and Temporary Sector Unprotection (A_9 , \overline{OE} , \overline{RESET}) *4, *5	V_{ID}	—	11.5	12.5	V	
Output Low Voltage	V_{OL}	$I_{OL} = 4.0$ mA, $V_{CC} = V_{CC}$ Min	—	0.45	V	
Output High Voltage	V_{OH1}	$I_{OH} = -2.0$ mA, $V_{CC} = V_{CC}$ Min	2.4	—	V	
	V_{OH2}	$I_{OH} = -100$ μA	$V_{CC} - 0.4$	—	V	
Low V _{CC} Lock-Out Voltage	V_{LKO}	—	2.3	2.5	V	

*1 : The I_{CC} current listed includes both the DC operating current and the frequency dependent component.

*2 : I_{CC} active while Embedded Erase or Embedded Program is in progress.

*3 : Automatic sleep mode enables the low power mode when address remain stable for 150 ns.

*4 : The timing is only for Sector Protection operation and Autoselect mode.

*5 : ($V_{ID} - V_{CC}$) do not exceed 9 V.

MBM29LV160T-80/-90/-12/MBM29LV160B-80/-90/-12

■ AC CHARACTERISTICS

• Read Only Operations Characteristics

Parameter	Symbol		Test Setup	-80*		-90*		-12*		Unit
	JEDEC	Standard		Min	Max	Min	Max	Min	Max	
Read Cycle Time	t _{AVAV}	t _{RC}	—	80	—	90	—	120	—	ns
Address to Output Delay	t _{AVQV}	t _{ACC}	$\overline{CE} = V_{IL}$ $\overline{OE} = V_{IL}$	—	80	—	90	—	120	ns
Chip Enable to Output Delay	t _{ELQV}	t _{CE}	$\overline{OE} = V_{IL}$	—	80	—	90	—	120	ns
Output Enable to Output Delay	t _{GLQV}	t _{OE}	—	—	30	—	35	—	50	ns
Chip Enable to Output High-Z	t _{EHQZ}	t _{DF}	—	—	25	—	30	—	30	ns
Output Enable to Output High-Z	t _{GHQZ}	t _{DF}	—	—	25	—	30	—	30	ns
Output Hold Time From Address, \overline{CE} or \overline{OE} , Whichever Occurs First	t _{AXQX}	t _{OH}	—	0	—	0	—	0	—	ns
\overline{RESET} Pin Low to Read Mode	—	t _{READY}	—	—	20	—	20	—	20	μs
\overline{CE} to \overline{BYTE} Switching Low or High	—	t _{ELFL} t _{ELFH}	—	—	5	—	5	—	5	ns

* : Test Conditions: Output Load: 1 TTL gate and 30 pF (MBM29LV160T/B-80/-90)
1 TTL gate and 100 pF (MBM29LV160T/B-12)

Input rise and fall times: 5 ns
Input pulse levels: 0.0 V or 3.0 V
Timing measurement reference level
Input: 1.5 V
Output: 1.5 V

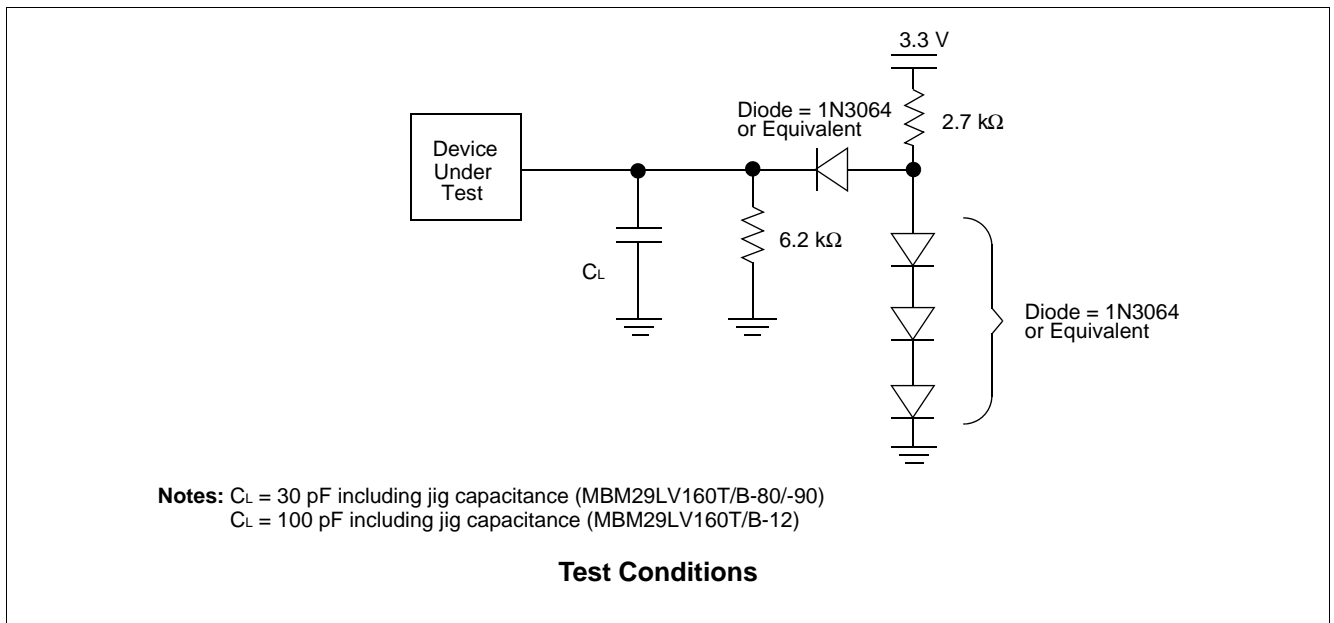

MBM29LV160T-80/-90/-12/MBM29LV160B-80/-90/-12

• Write (Erase/Program) Operations

Parameter	Symbol		-80			-90			-12			Unit	
	JEDEC	Standard	Min	Typ	Max	Min	Typ	Max	Min	Typ	Max		
Write Cycle Time	t _{AVAV}	t _{WC}	80	—	—	90	—	—	120	—	—	ns	
Address Setup Time	t _{AVWL}	t _{AS}	0	—	—	0	—	—	0	—	—	ns	
Address Hold Time	t _{WLAX}	t _{AH}	45	—	—	45	—	—	50	—	—	ns	
Data Setup Time	t _{DVWH}	t _{DS}	35	—	—	45	—	—	50	—	—	ns	
Data Hold Time	t _{WHDX}	t _{DH}	0	—	—	0	—	—	0	—	—	ns	
Output Enable Setup Time	—	t _{OES}	0	—	—	0	—	—	0	—	—	ns	
Output Enable Hold Time	Read	—	t _{OEH}	0	—	—	0	—	—	0	—	—	ns
	Toggle and Data Polling			10	—	—	10	—	—	10	—	—	ns
Read Recover Time Before Write	t _{GHWL}	t _{GHWL}	0	—	—	0	—	—	0	—	—	ns	
Read Recover Time Before Write (OE High to CE Low)	t _{GHEL}	t _{GHEL}	0	—	—	0	—	—	0	—	—	ns	
CE Setup Time	t _{ELWL}	t _{CS}	0	—	—	0	—	—	0	—	—	ns	
WE Setup Time	t _{WLEL}	t _{WS}	0	—	—	0	—	—	0	—	—	ns	
CE Hold Time	t _{WHEH}	t _{CH}	0	—	—	0	—	—	0	—	—	ns	
WE Hold Time	t _{EHWH}	t _{WH}	0	—	—	0	—	—	0	—	—	ns	
Write Pulse Width	t _{WLWH}	t _{WP}	35	—	—	45	—	—	50	—	—	ns	
CE Pulse Width	t _{ELEH}	t _{CP}	35	—	—	45	—	—	50	—	—	ns	
Write Pulse Width High	t _{WHWL}	t _{WPH}	25	—	—	25	—	—	30	—	—	ns	
CE Pulse Width High	t _{EHEL}	t _{CPH}	25	—	—	25	—	—	30	—	—	ns	
Programming Operation	Byte	t _{WHWH1}	t _{WHWH1}	—	8	—	—	8	—	8	—	μs	
	Word			—	16	—	—	16	—	16	—		
Sector Erase Operation *1	t _{WHWH2}	t _{WHWH2}	—	1	—	—	1	—	—	1	—	s	
Delay Time from Embedded Output Enable	—	t _{EOE}	—	—	80	—	—	90	—	—	120	ns	
V _{CC} Setup Time	—	t _{VCS}	50	—	—	50	—	—	50	—	—	μs	
Voltage Transition Time *2	—	t _{VLHT}	4	—	—	4	—	—	4	—	—	μs	
Write Pulse Width *2	—	t _{WPP}	100	—	—	100	—	—	100	—	—	μs	
OE Setup Time to WE Active *2	—	t _{OESP}	4	—	—	4	—	—	4	—	—	μs	
CE Setup Time to WE Active *2	—	t _{CSP}	4	—	—	4	—	—	4	—	—	μs	
Recover Time From RY/BY	—	t _{RB}	0	—	—	0	—	—	0	—	—	ns	
RESET Hold Time Before Read	—	t _{RH}	200	—	—	200	—	—	200	—	—	ns	
Program/Erase Valid to RY/BY Delay	—	t _{BUSY}	—	—	90	—	—	90	—	—	90	ns	
BYTE Switching Low to Output High-Z	—	t _{FLQZ}	—	—	25	—	—	30	—	—	30	ns	
BYTE Switching High to Output Active	—	t _{FHQV}	—	—	80	—	—	90	—	—	120	ns	
Rise Time to V _{ID} *2	—	t _{VIDR}	500	—	—	500	—	—	500	—	—	ns	
RESET Pulse Width	—	t _{RP}	500	—	—	500	—	—	500	—	—	ns	

*1 : This does not include the preprogramming time.

*2 : This timing is for Sector Protection operation.

MBM29LV160T-80/-90/-12/MBM29LV160B-80/-90/-12

■ ERASE AND PROGRAMMING PERFORMANCE

Parameter	Limits			Unit	Comments
	Min	Typ	Max		
Sector Erase Time	—	1	10	s	Excludes programming time prior to erasure
Byte Programming Time	—	8	360	μs	Excludes system-level overhead
Word Programming Time	—	16	300		
Chip Programming Time	—	16.8	50	s	Excludes system-level overhead
Erase/Program Cycle	100,000	—	—	cycle	—

■ TSOP (1) PIN CAPACITANCE

(f = 1.0 MHz, T_A = +25 °C)

Parameter	Symbol	Test Setup	Typ	Max	Unit
Input Capacitance	C _{IN}	V _{IN} = 0	7.5	9.5	pF
Output Capacitance	C _{OUT}	V _{OUT} = 0	8	10	pF
Control Pin Capacitance	C _{IN2}	V _{IN} = 0	10	13	pF

Note : DQ₁₅/A-1 pin capacitance is stipulated by output capacitance.

■ CSOP PIN CAPACITANCE

(f = 1.0 MHz, T_A = +25 °C)

Parameter	Symbol	Test Setup	Typ	Max	Unit
Input Capacitance	C _{IN}	V _{IN} = 0	7.5	9.5	pF
Output Capacitance	C _{OUT}	V _{OUT} = 0	8	10	pF
Control Pin Capacitance	C _{IN2}	V _{IN} = 0	10	13	pF

Note : DQ₁₅/A-1 pin capacitance is stipulated by output capacitance.

■ FBGA PIN CAPACITANCE

(f = 1.0 MHz, T_A = +25 °C)



Parameter	Symbol	Test Setup	Typ	Max	Unit
Input Capacitance	C _{IN}	V _{IN} = 0	7.5	9.5	pF
Output Capacitance	C _{OUT}	V _{OUT} = 0	8	10	pF
Control Pin Capacitance	C _{IN2}	V _{IN} = 0	10	13	pF

Note : DQ₁₅/A-1 pin capacitance is stipulated by output capacitance.

MBM29LV160T-80/-90/-12/MBM29LV160B-80/-90/-12

■ TIMING DIAGRAM

- Key to Switching Waveforms

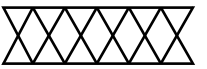
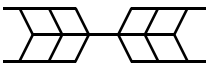
WAVEFORM	INPUTS	OUTPUTS
	Must Be Steady	Will Be Steady
	May Change from H to L	Will Be Change from H to L
	May Change from L to H	Will Be Change from L to H
	"H" or "L": Any Change Permitted	Changing, State Unknown
	Does Not Apply	Center Line is High-Impedance "Off" State

(1) AC Waveforms for Read Operations

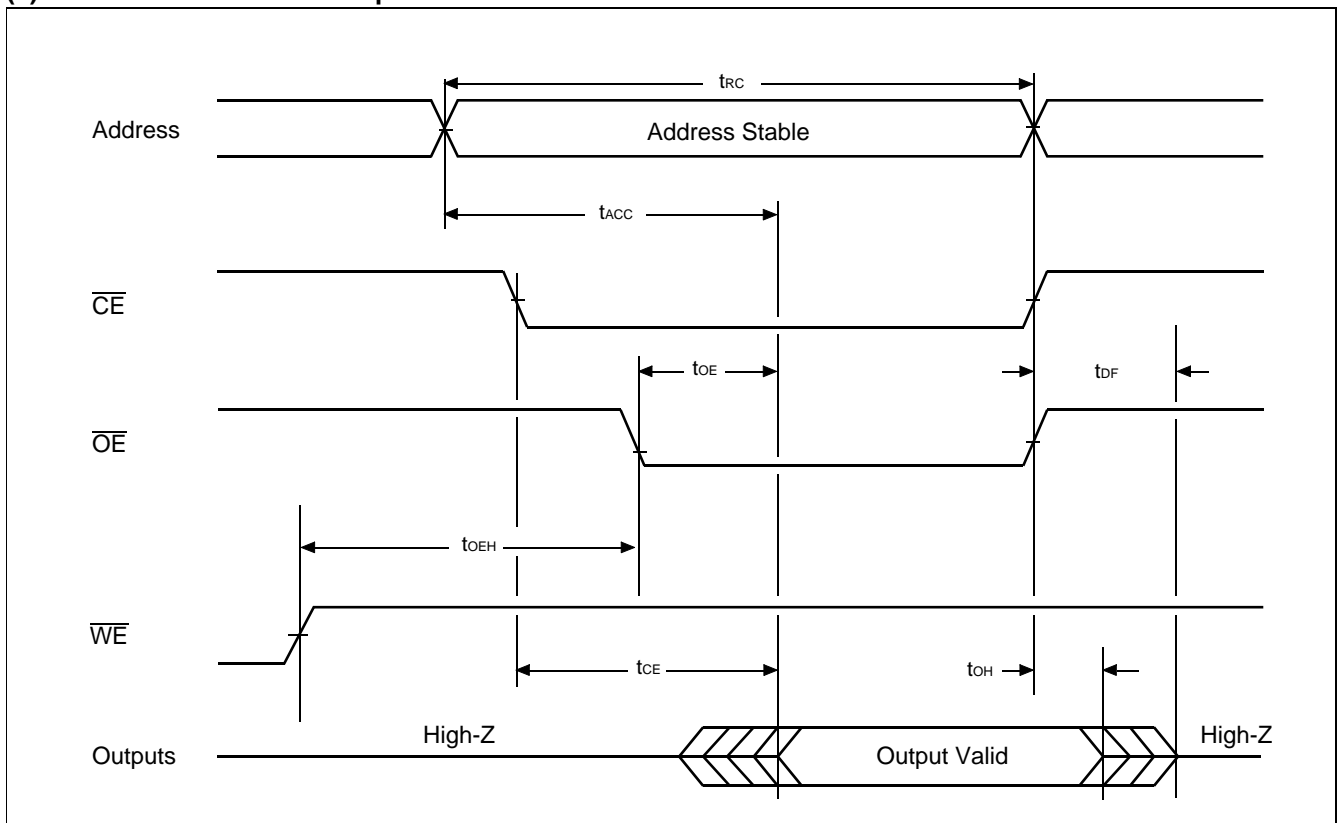

MBM29LV160T-80/-90/-12/MBM29LV160B-80/-90/-12

(2) AC Waveforms for Hardware Reset/Read Operations

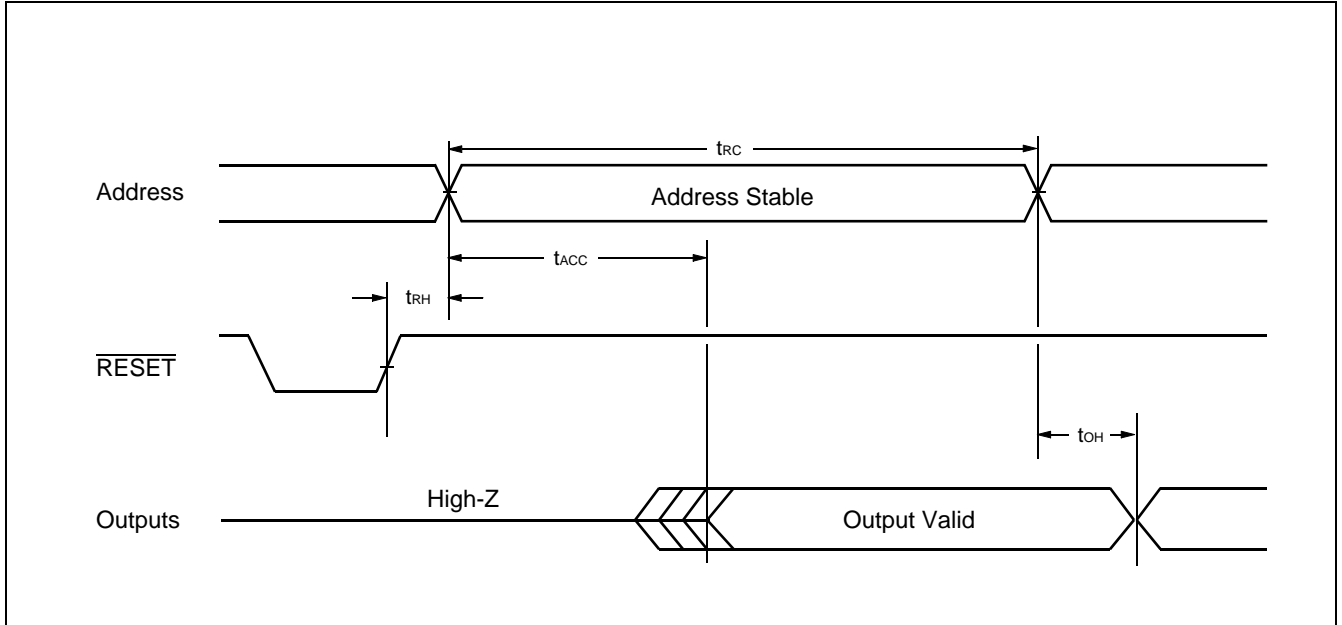

(3) AC Waveforms for Alternate \overline{WE} Controlled Program Operations

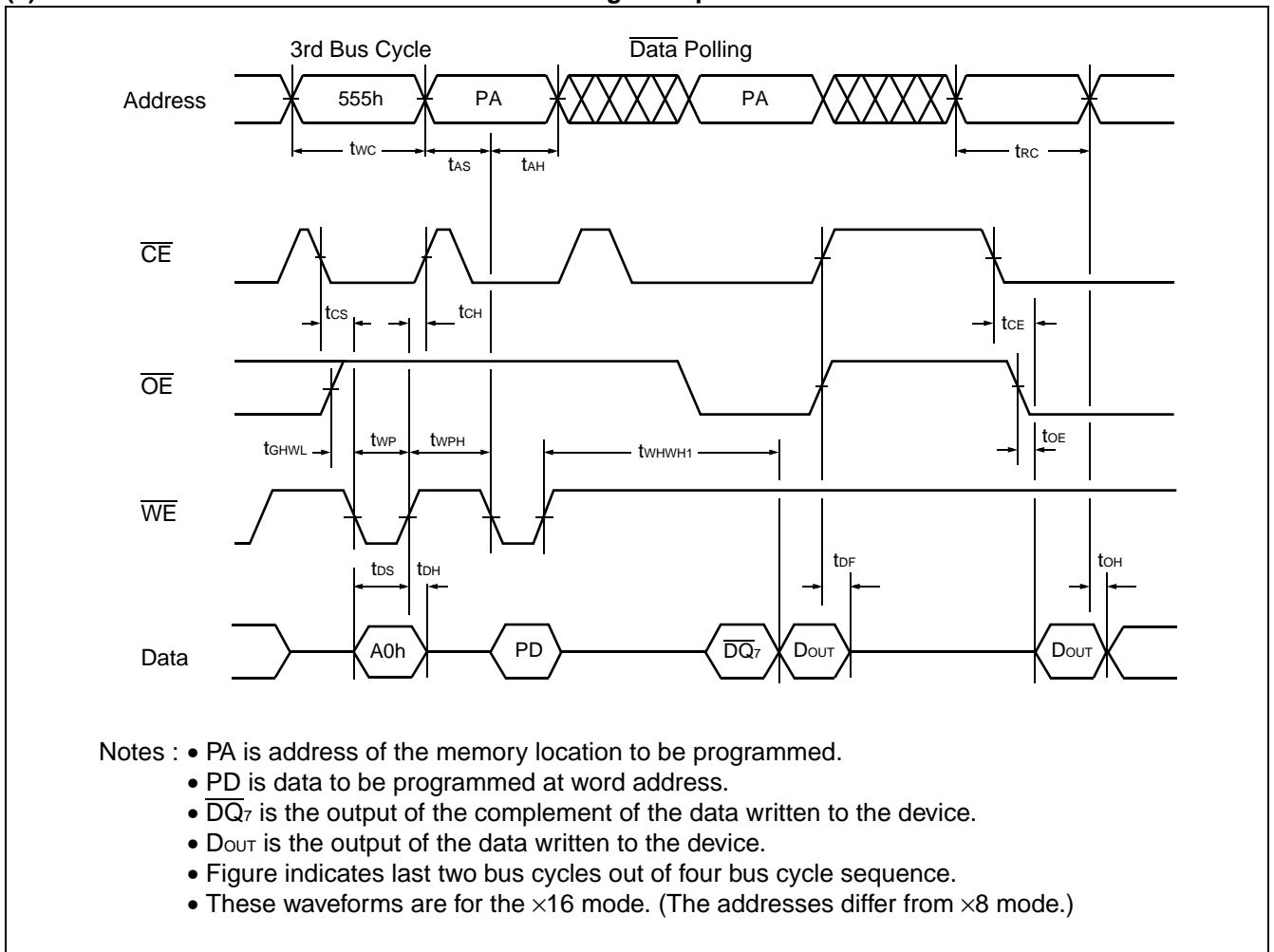

MBM29LV160T-80/-90/-12/MBM29LV160B-80/-90/-12

(4) AC Waveforms for Alternate $\overline{\text{CE}}$ Controlled Program Operations

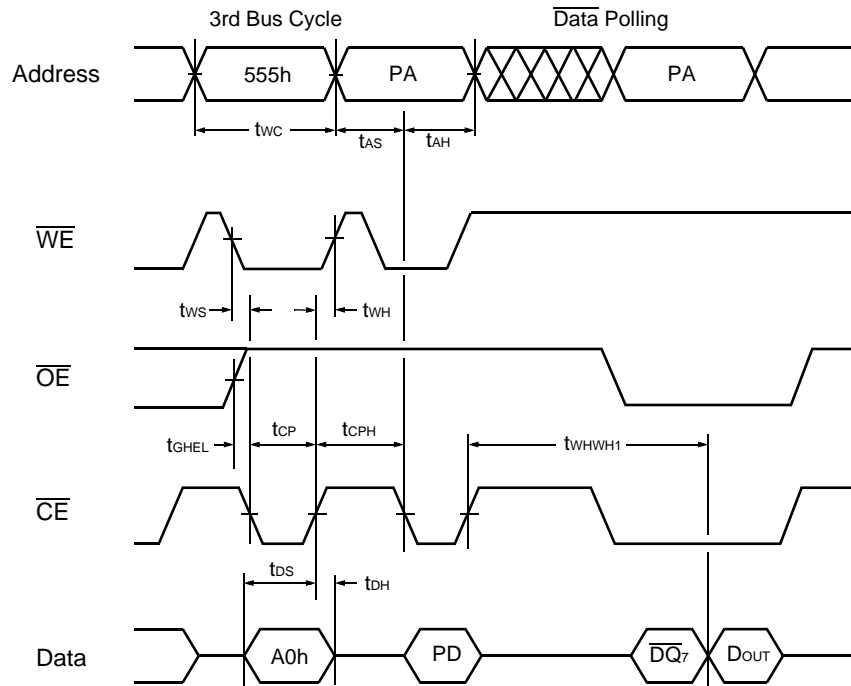

- Notes :
- PA is address of the memory location to be programmed.
 - PD is data to be programmed at word address.
 - $\overline{\text{DQ}}_7$ is the output of the complement of the data written to the device.
 - D_{OUT} is the output of the data written to the device.
 - Figure indicates last two bus cycles out of four bus cycle sequence.
 - These waveforms are for the $\times 16$ mode. (The addresses differ from $\times 8$ mode.)

MBM29LV160T-80/-90/-12/MBM29LV160B-80/-90/-12

(5) AC Waveforms for Chip/Sector Erase Operations

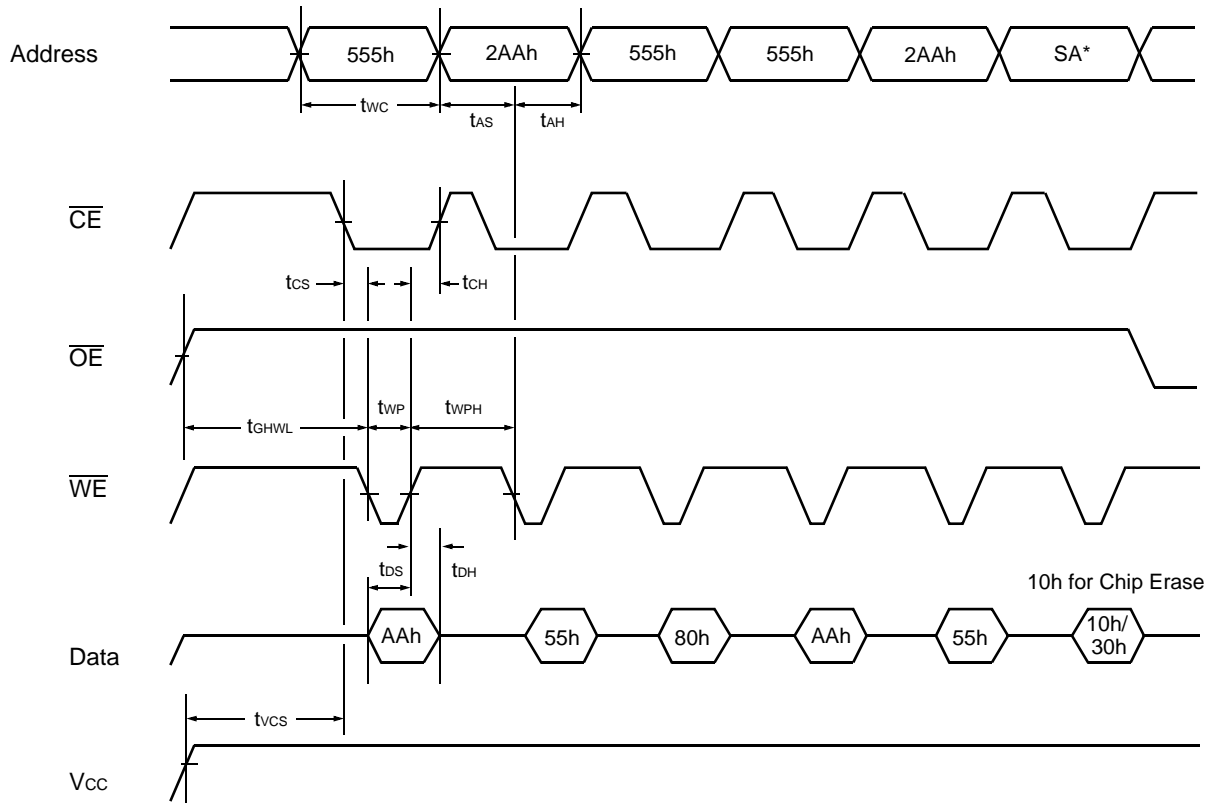

* : SA is the sector address for Sector Erase. Addresses = 555h (Word), AAAAh (Byte) for Chip Erase.

Note: These waveforms are for the $\times 16$ mode. (The addresses differ from $\times 8$ mode.)

MBM29LV160T-80/-90/-12/MBM29LV160B-80/-90/-12

(6) AC Waveforms for Data Polling during Embedded Algorithm Operations

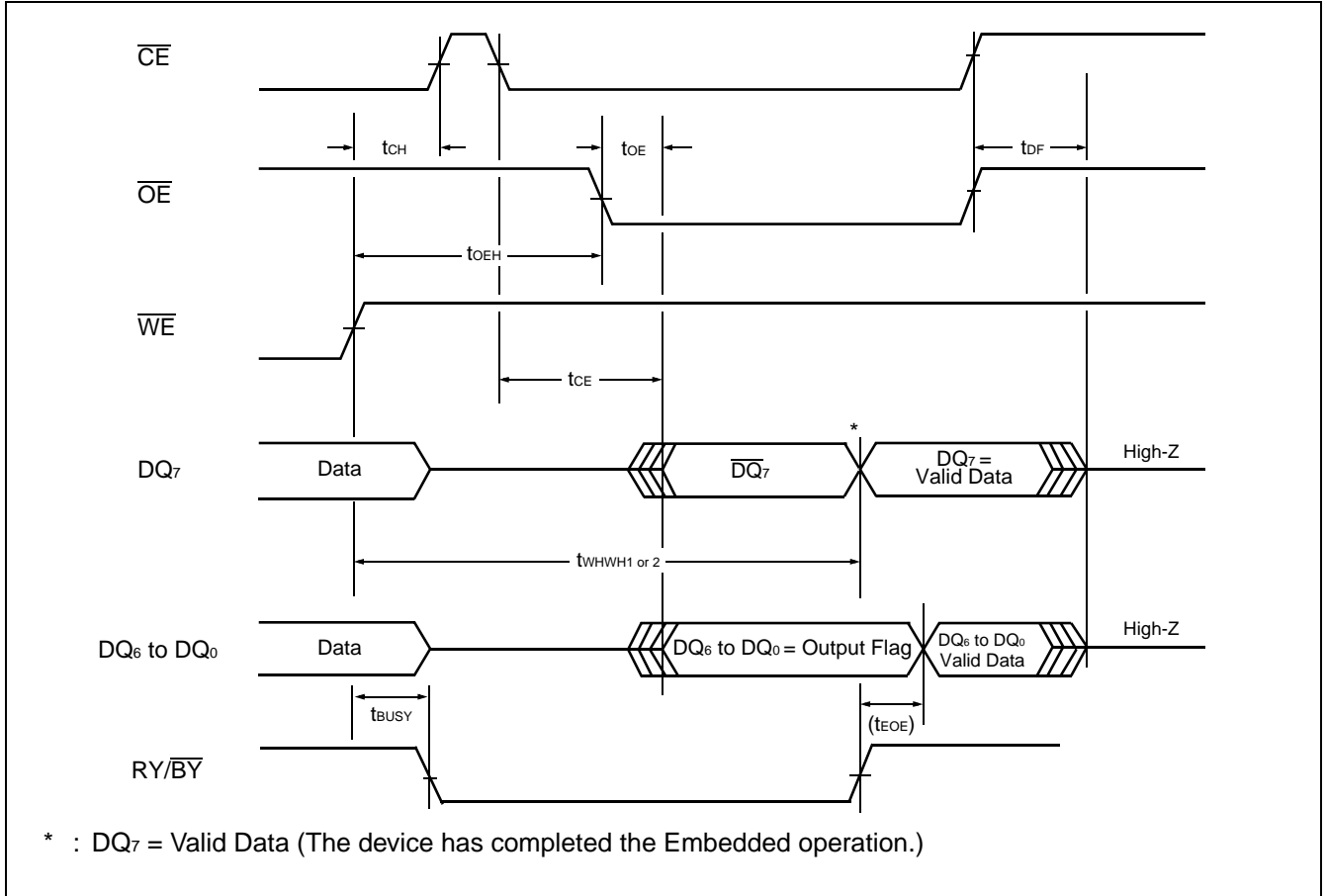

(7) AC Waveforms for Toggle Bit I during Embedded Algorithm Operations

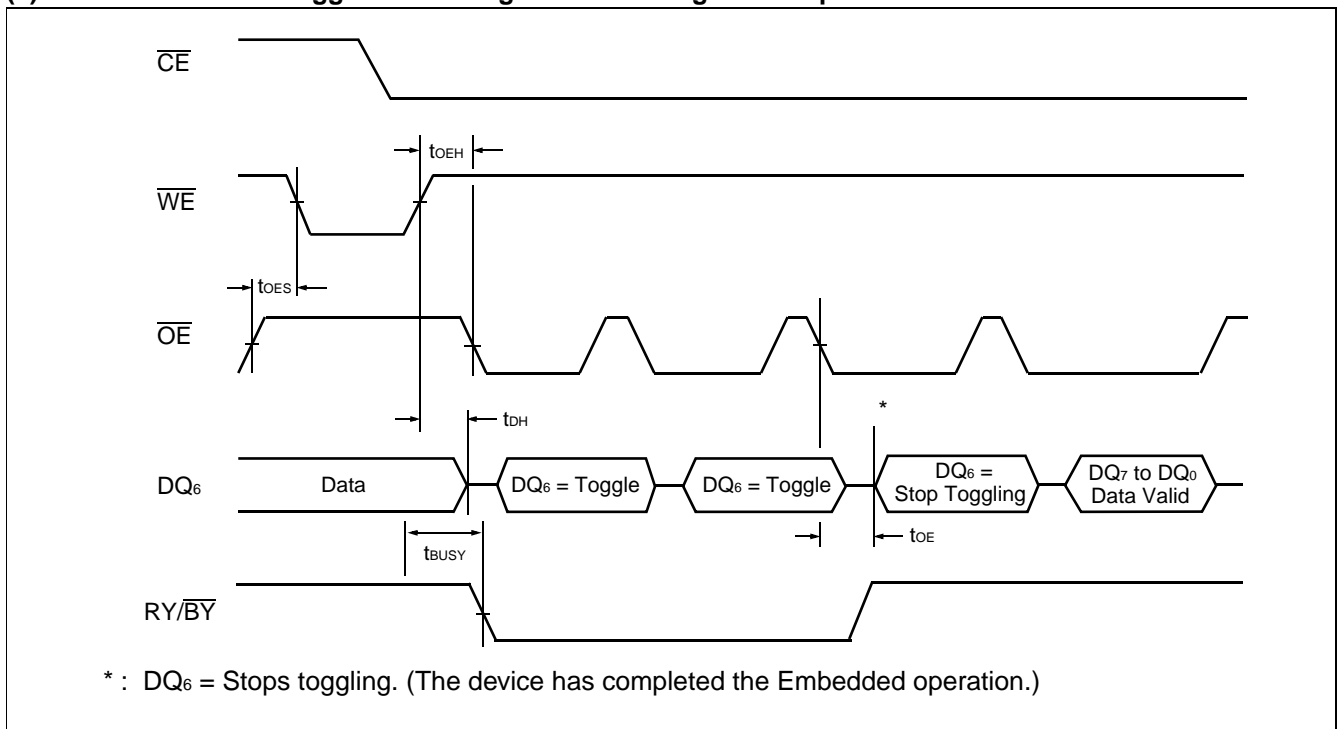

MBM29LV160T-80/-90/-12/MBM29LV160B-80/-90/-12

(8) RY/ $\overline{\text{BY}}$ Timing Diagram during Program/Erase Operations

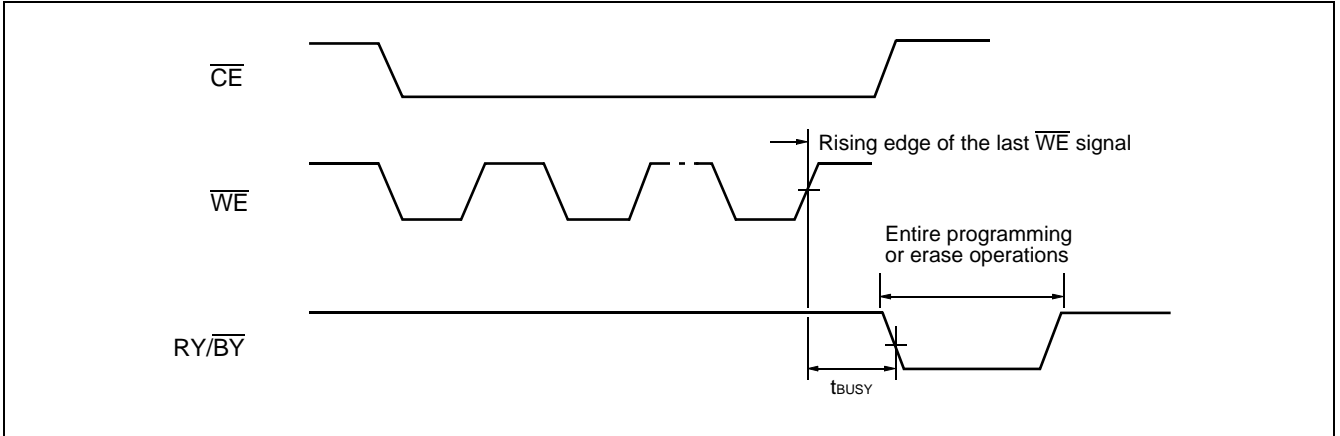

(9) RESET, RY/ $\overline{\text{BY}}$ Timing Diagram

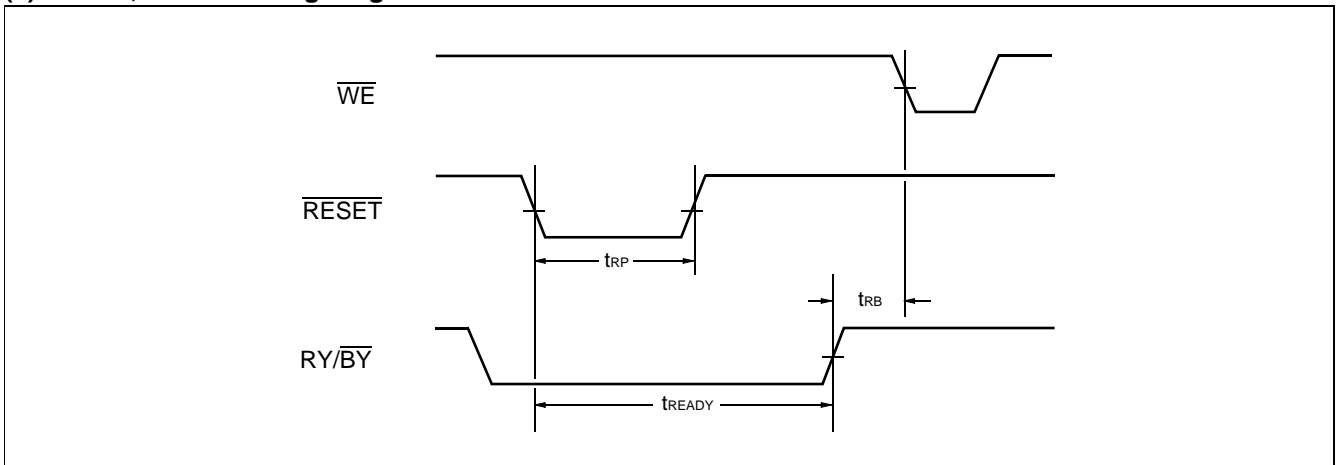

(10) Timing Diagram for Word Mode Configuration

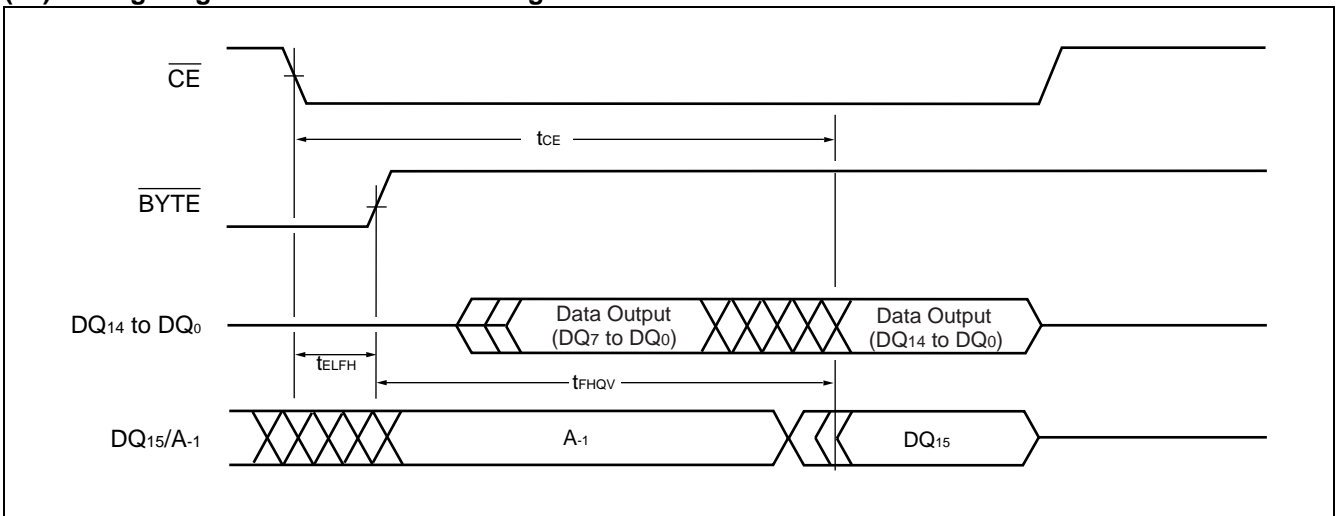

MBM29LV160T-80/-90/-12/MBM29LV160B-80/-90/-12

(11) Timing Diagram for Byte Mode Configuration

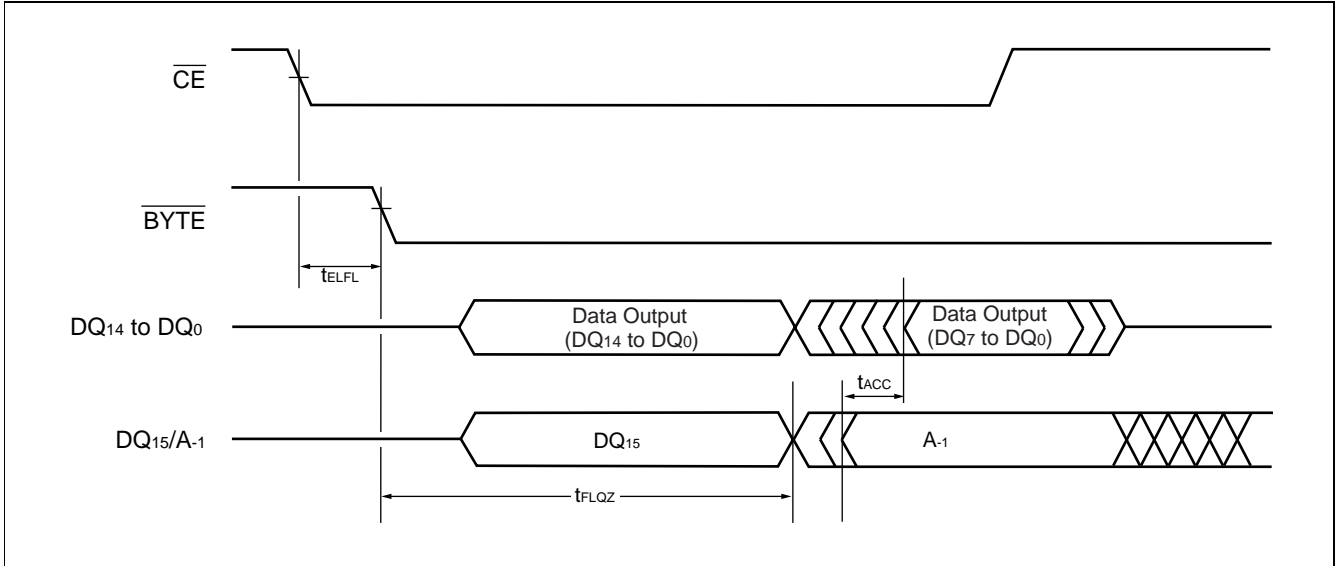

(12) \overline{BYTE} Timing Diagram for Write Operations

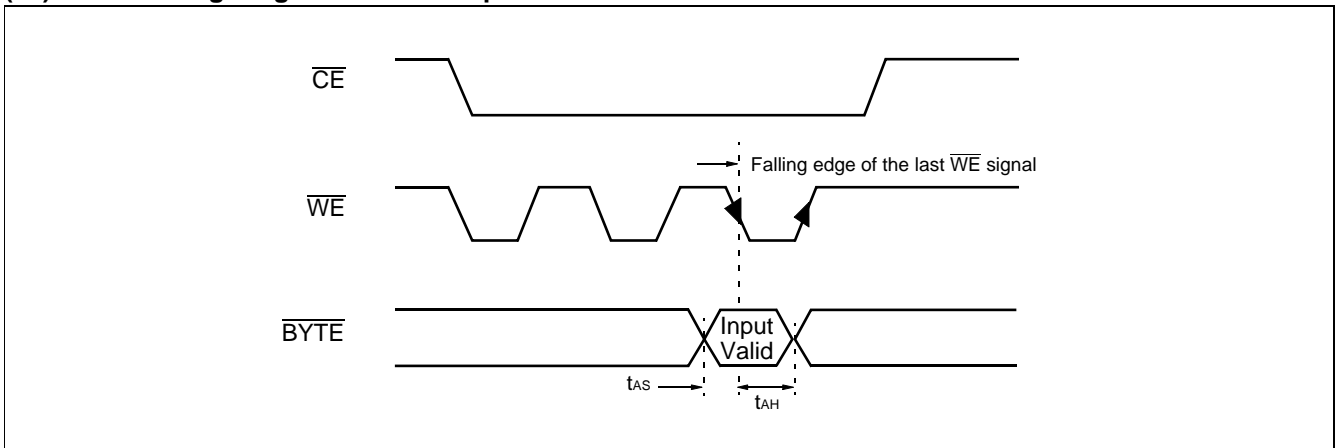

MBM29LV160T-80/-90/-12/MBM29LV160B-80/-90/-12

(13) AC Waveforms for Sector Protection Timing Diagram

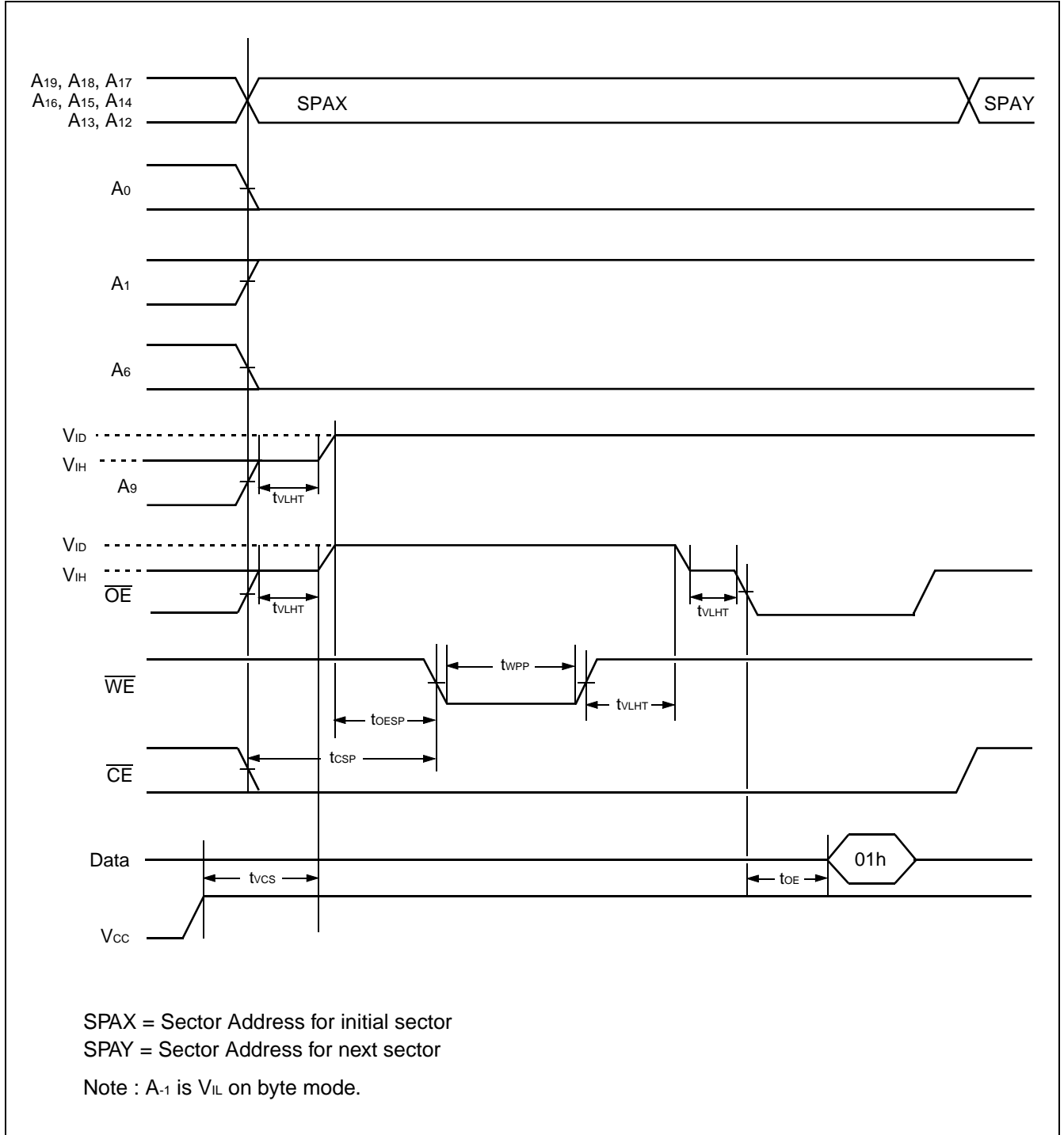

MBM29LV160T-80/-90/-12/MBM29LV160B-80/-90/-12

(14) Extended Sector Protection Timing Diagram

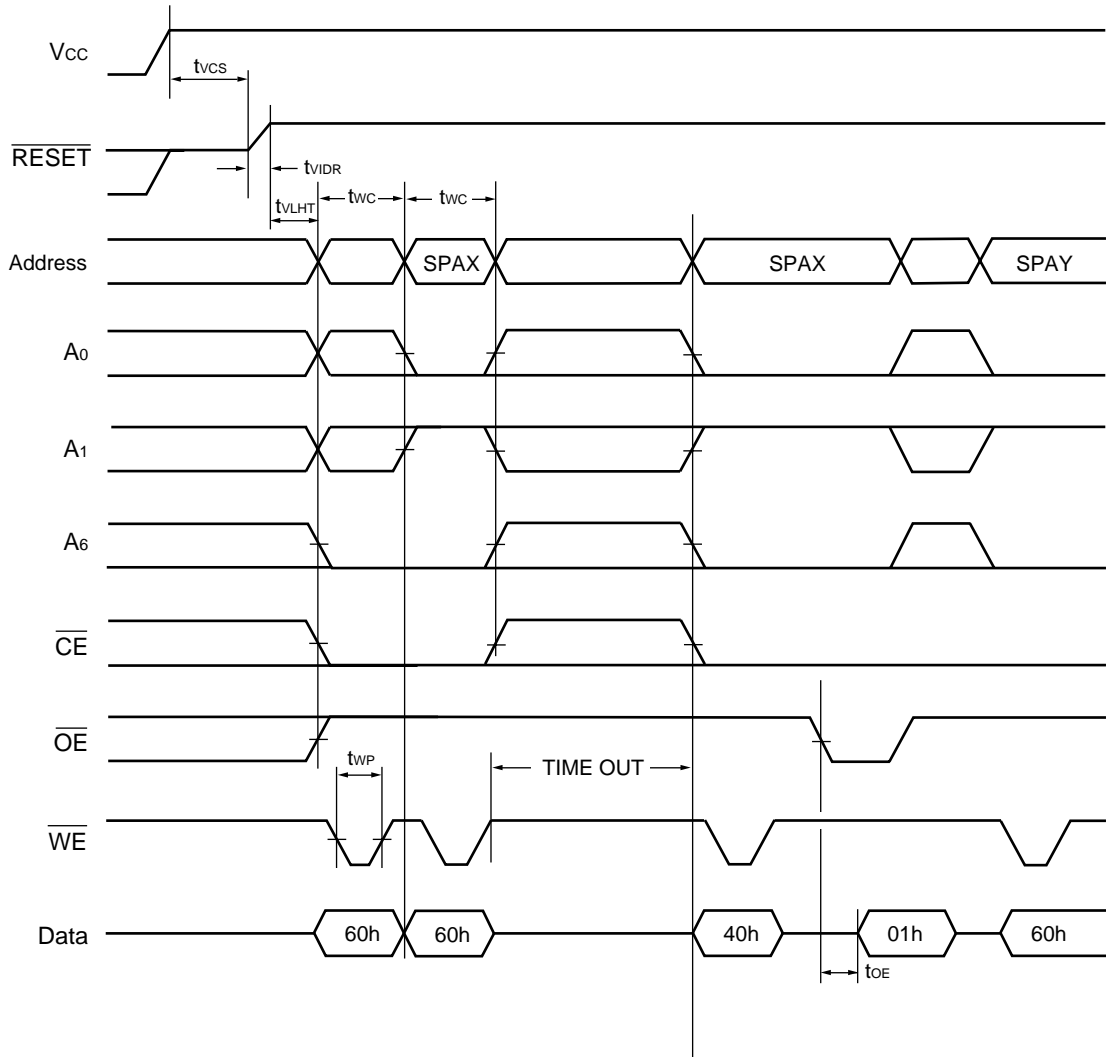

SPAX : Sector Address to be protected
 SPAY : Next Sector Address to be protected
 TIME-OUT : Time-out Window = 150 μs (Min)

MBM29LV160T-80/-90/-12/MBM29LV160B-80/-90/-12

(15) Temporary Sector Unprotection Timing Diagram

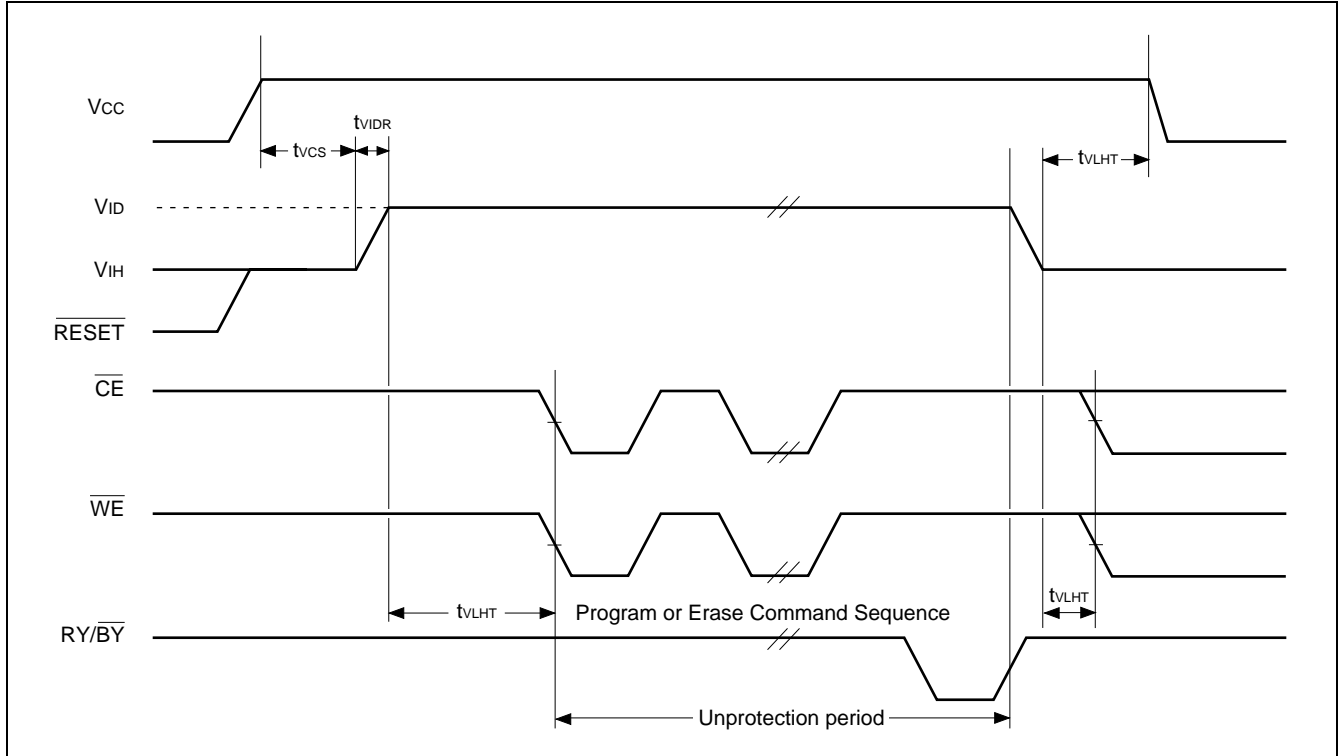

(16) DQ₂ vs. DQ₆

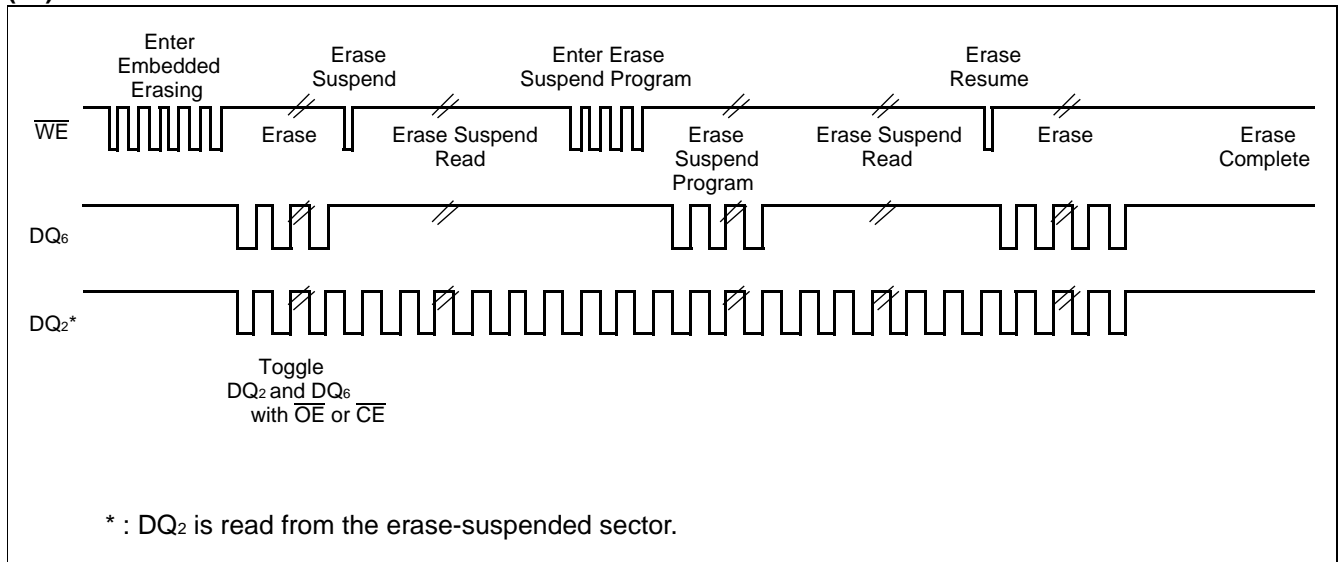

■ FLOW CHART

(1) Embedded Program™ Algorithm

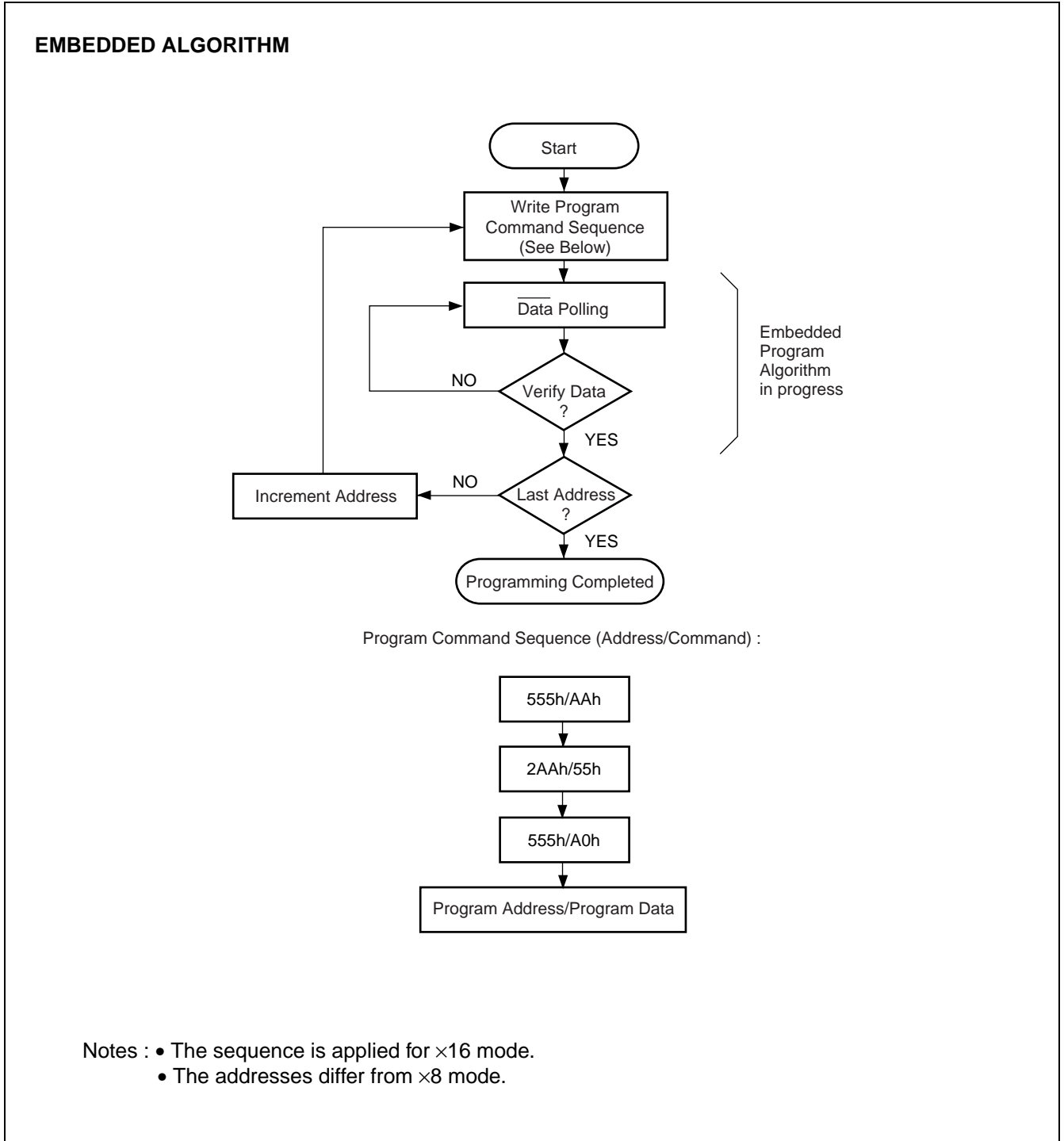

MBM29LV160T-80/-90/-12/MBM29LV160B-80/-90/-12

(2) Embedded Erase™ Algorithm

EMBEDDED ALGORITHM

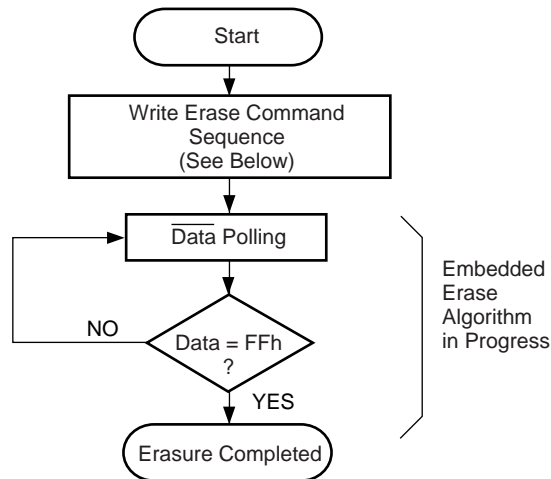

Chip Erase Command Sequence
(Address/Command) :

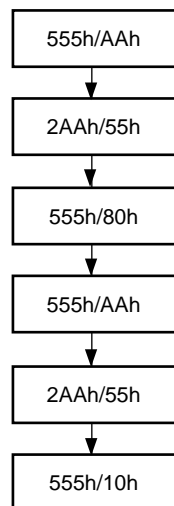

Individual Sector/Multiple Sector
Erase Command Sequence
(Address/Command) :

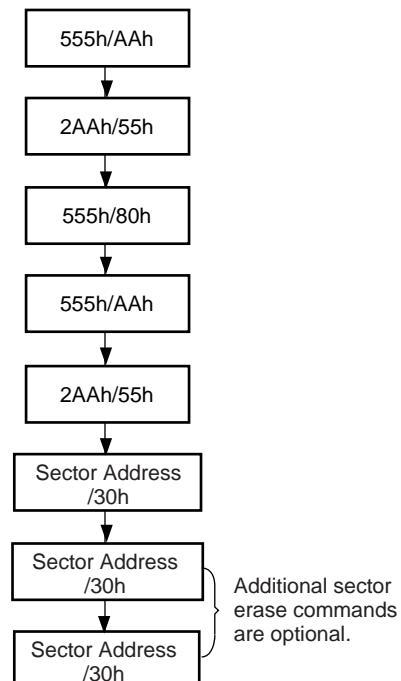

Note : The sequence is applied for ×16 mode.
The addresses differ from ×8 mode.

MBM29LV160T-80/-90/-12/MBM29LV160B-80/-90/-12

(3) Data Polling Algorithm

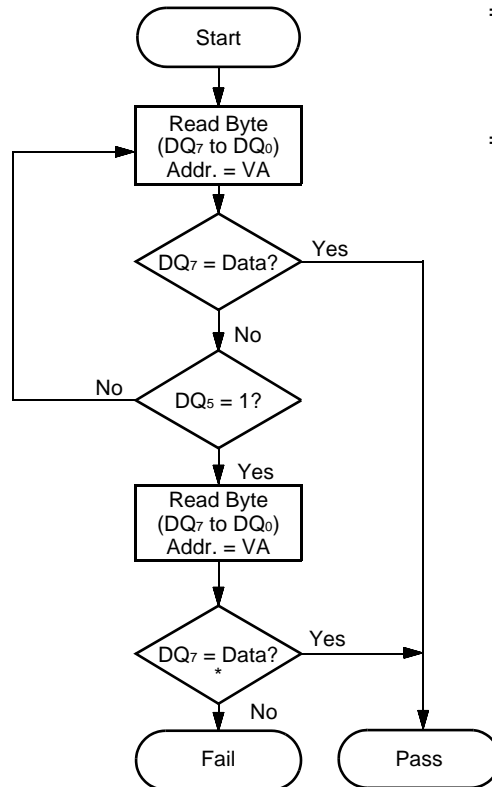

VA =Address for programming
=Any of the sector addresses within the sector being erased during sector erase or multiple sector erases operation.
=Any of the sector addresses within the sector not being protected during chip erases operation.

* : DQ₇ is rechecked even if DQ₅ = "1" because DQ₇ may change simultaneously with DQ₅.

(4) Toggle Bit Algorithm

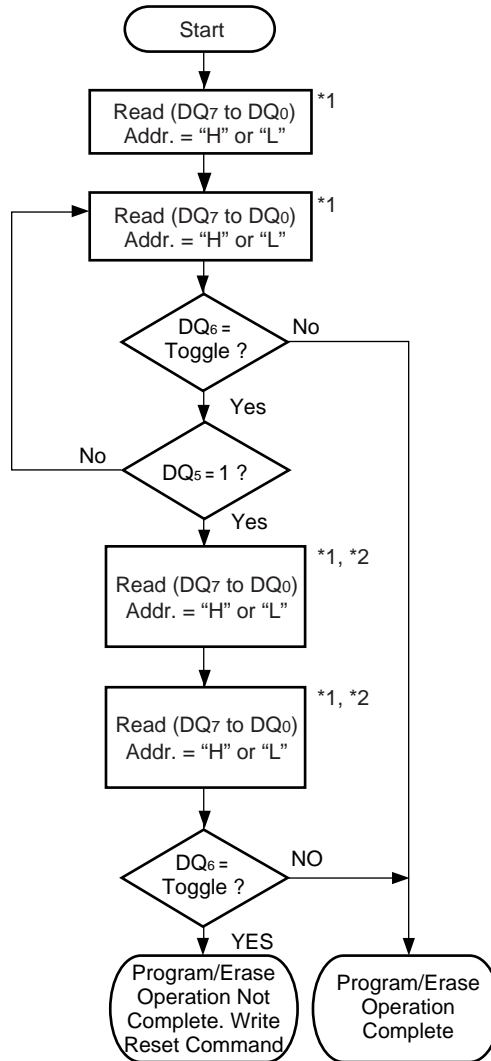

*1 : Read toggle bit twice to determine whether it is toggling.

*2 : Recheck toggle bit because it may stop toggling as DQ₅ changes to "1".

(5) Sector Protection Algorithm

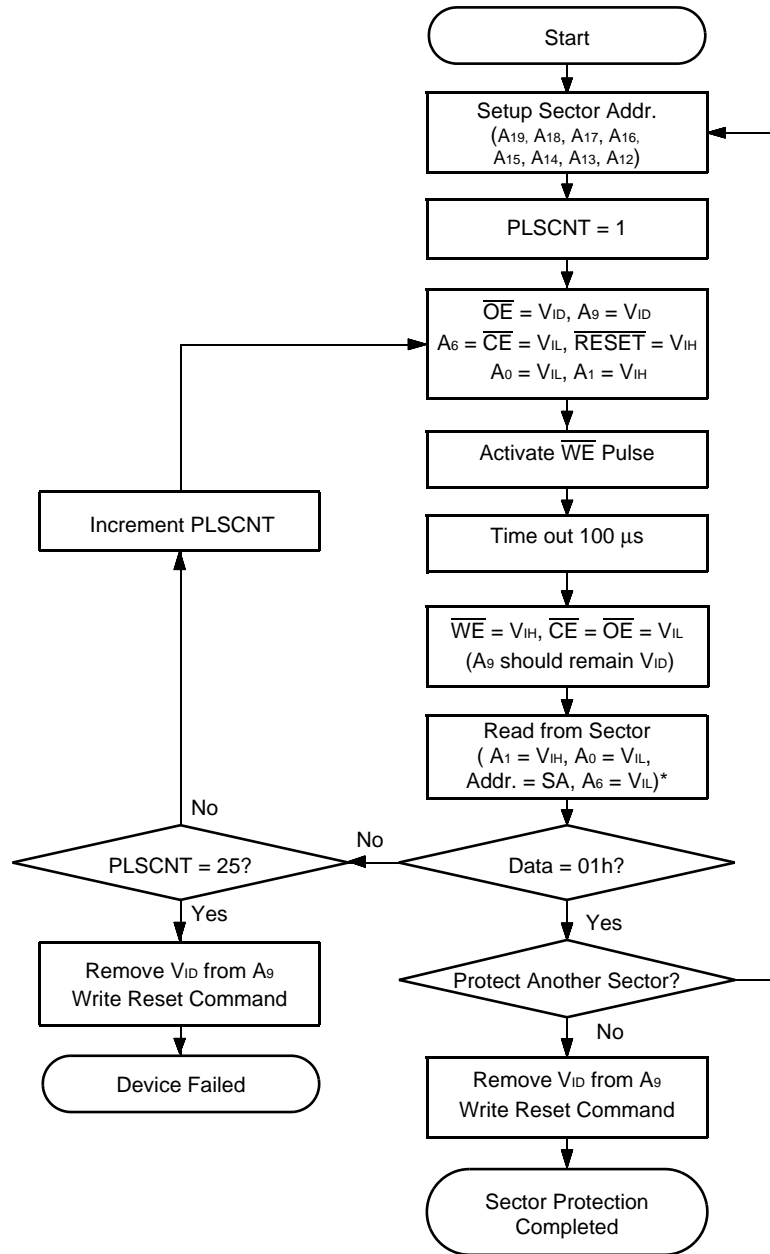

* : A-1 is V_{IL} on byte mode.

(6) Temporary Sector Unprotection Algorithm

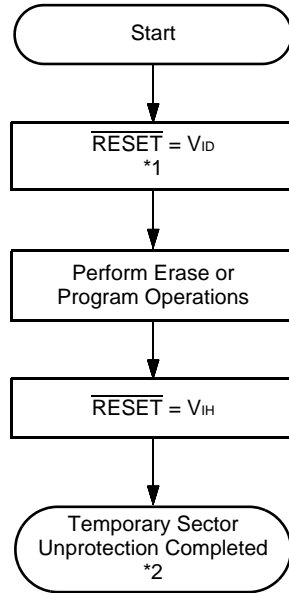

*1 : All protected sectors are unprotected.

*2 : All previously protected sectors are protected once again.

MBM29LV160T-80/-90/-12/MBM29LV160B-80/-90/-12

(7) Embedded Programming Algorithm for Fast Mode

FAST MODE ALGORITHM

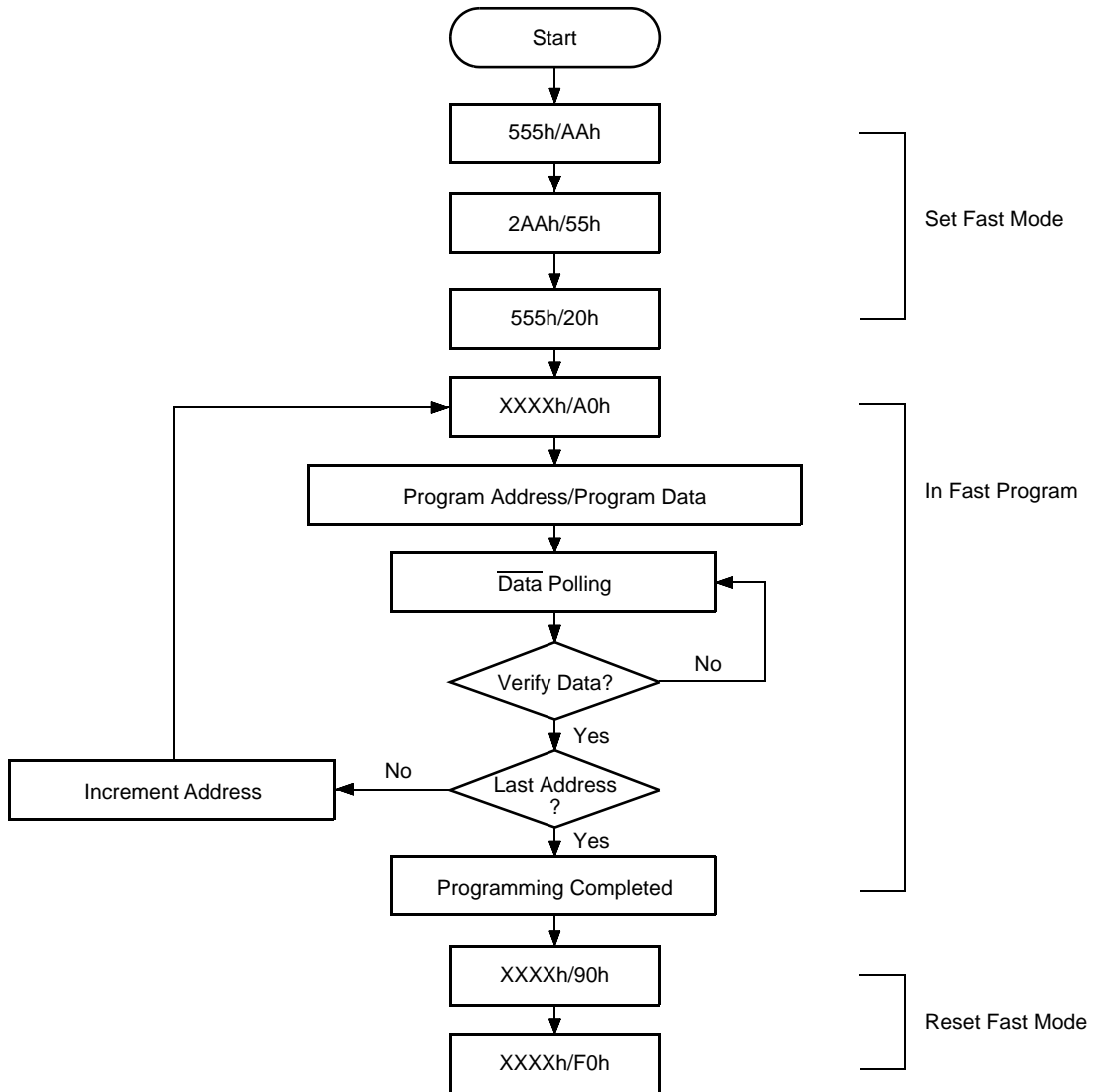

- Notes :
- The sequence is applied for $\times 16$ mode.
 - The addresses differ from $\times 8$ mode.

(8) Extended Sector Protect Algorithm

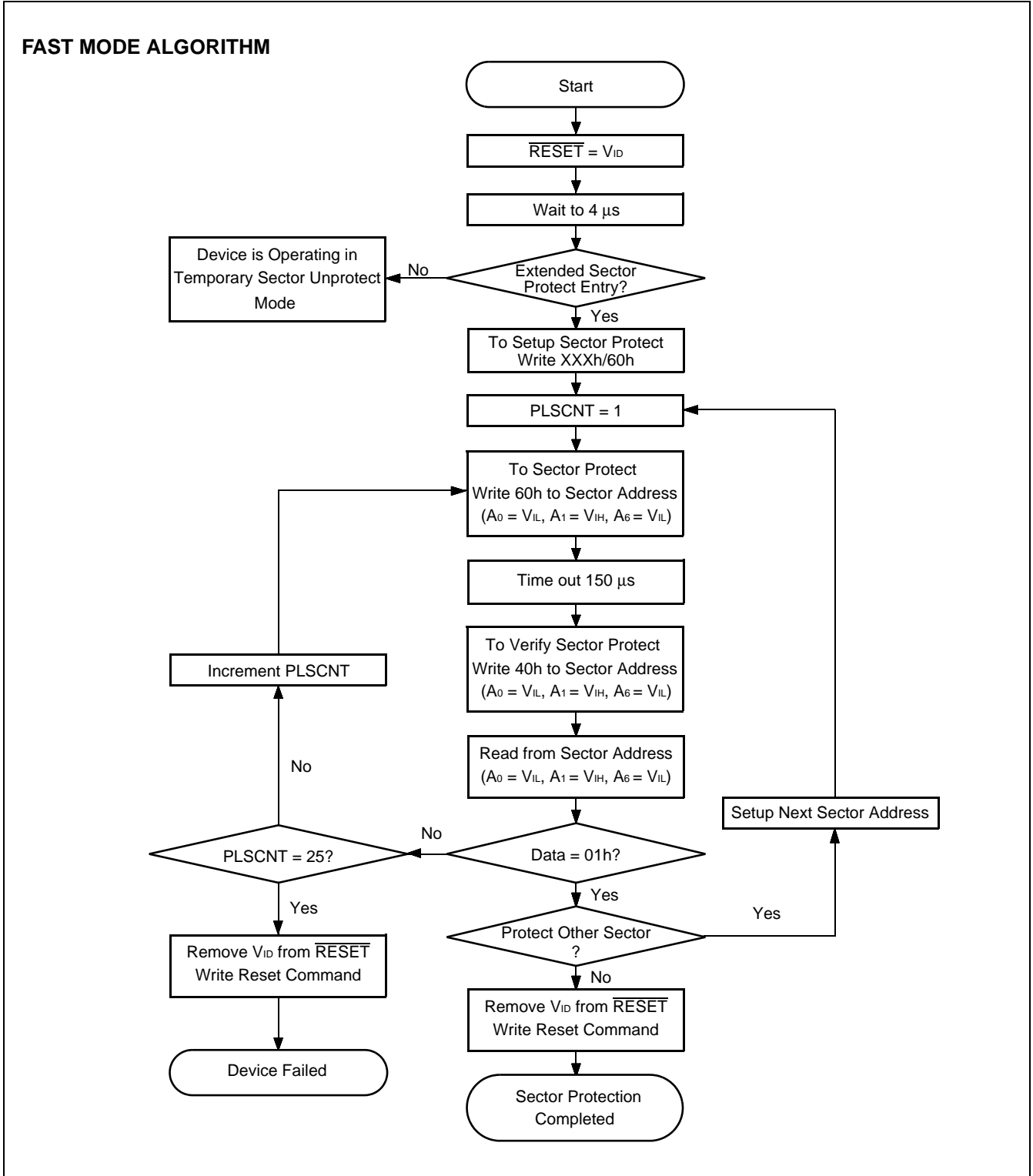

MBM29LV160T-80/-90/-12/MBM29LV160B-80/-90/-12

■ ORDERING INFORMATION

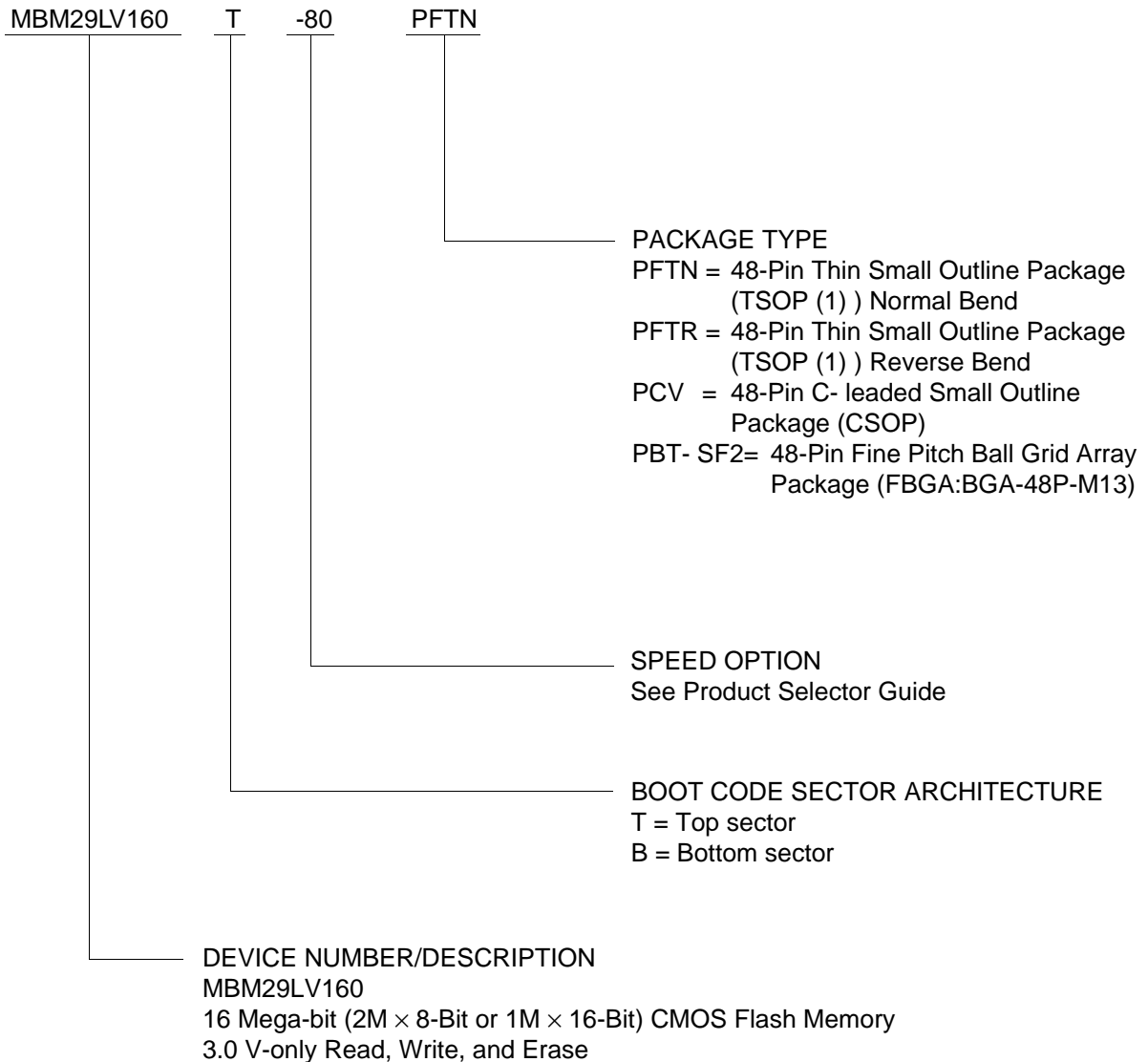

MBM29LV160T-80/-90/-12/MBM29LV160B-80/-90/-12

Part No.	Package	Access Time (ns)	Sector Architecture
MBM29LV160T-80PFTN	48-pin plastic TSOP(1) (FPT-48P-M19) (Normal Bend)	80	Top Sector
MBM29LV160T-90PFTN		90	
MBM29LV160T-12PFTN		120	
MBM29LV160T-80PFTR	48-pin plastic TSOP(1) (FPT-48P-M20) (Reverse Bend)	80	
MBM29LV160T-90PFTR		90	
MBM29LV160T-12PFTR		120	
MBM29LV160T-80PCV	48-pin plastic CSOP (LCC-48P-M03)	80	
MBM29LV160T-90PCV		90	
MBM29LV160T-12PCV		120	
MBM29LV160T-80PBT	48-ball plastic FBGA (BGA-48P-M13)	80	
MBM29LV160T-90PBT		90	
MBM29LV160T-12PBT		120	
MBM29LV160B-80PFTN	48-pin plastic TSOP(1) (FPT-48P-M19) (Normal Bend)	80	Bottom Sector
MBM29LV160B-90PFTN		90	
MBM29LV160B-12PFTN		120	
MBM29LV160B-80PFTR	48-pin plastic TSOP(1) (FPT-48P-M20) (Reverse Bend)	80	
MBM29LV160B-90PFTR		90	
MBM29LV160B-12PFTR		120	
MBM29LV160B-80PCV	48-pin plastic CSOP (LCC-48P-M03)	80	
MBM29LV160B-90PCV		90	
MBM29LV160B-12PCV		120	
MBM29LV160B-80PBT	48-ball plastic FBGA (BGA-48P-M13)	80	
MBM29LV160B-90PBT		90	
MBM29LV160B-12PBT		120	

MBM29LV160T-80/-90/-12/MBM29LV160B-80/-90/-12

■ PACKAGE DIMENSIONS

48-pin plastic TSOP (1)
(FPT-48P-M19)

Note 1) * : Values do not include resin protrusion.

Resin protrusion and gate protrusion are +0.15 (.006) Max (each side) .

Note 2) Pins width and pins thickness include plating thickness.

Note 3) Pins width do not include tie bar cutting remainder.

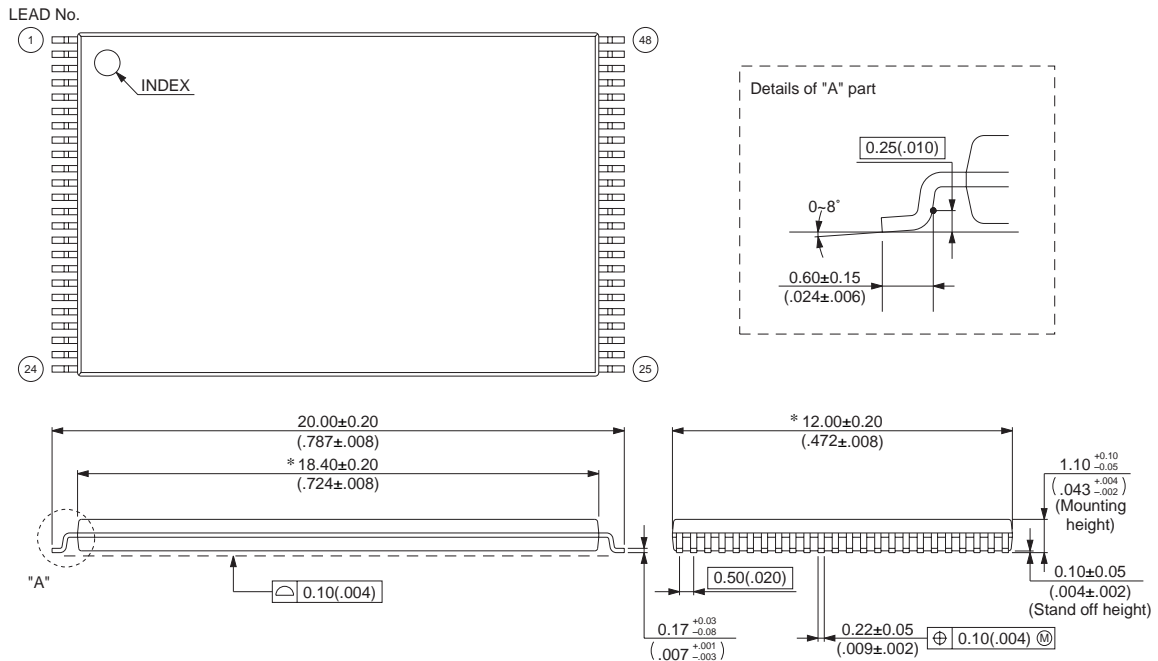

© 2003 FUJITSU LIMITED F48029S-c-6-7

Dimensions in mm (inches)

Note : The values in parentheses are reference values.

(Continued)

MBM29LV160T-80/-90/-12/MBM29LV160B-80/-90/-12

48-pin plastic TSOP (1)
(FPT-48P-M20)

- Note 1) * : Values do not include resin protrusion.
Resin protrusion and gate protrusion are +0.15 (.006) Max (each side) .
Note 2) Pins width and pins thickness include plating thickness.
Note 3) Pins width do not include tie bar cutting remainder.

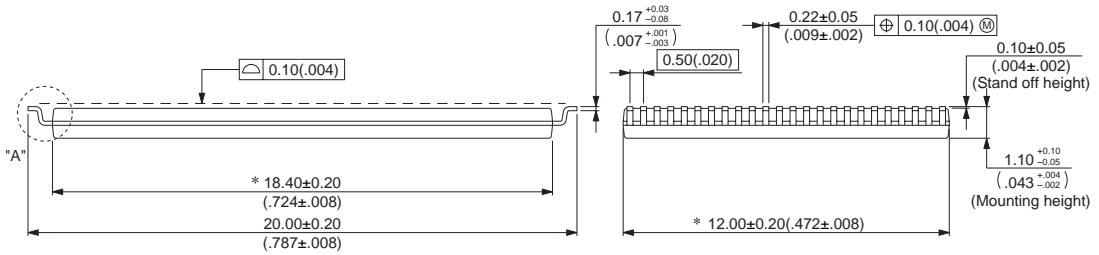
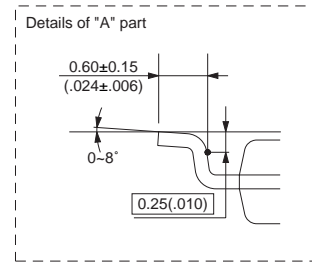
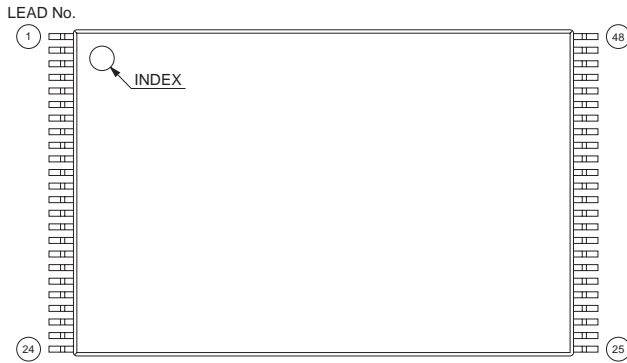

© 2003 FUJITSU LIMITED F48030S-c-6-7

Dimensions in mm (inches)

Note : The values in parentheses are reference values.

(Continued)

MBM29LV160T-80/-90/-12/MBM29LV160B-80/-90/-12

48-pin plastic CSOP
(LCC-48P-M03)

- Note 1) *1 : Resin protrusion. (Each side : +0.15 (.006) Max) .
 Note 2) *2 : These dimensions do not include resin protrusion.
 Note 3) Pins width includes plating thickness.
 Note 4) Pins width do not include tie bar cutting remainder.

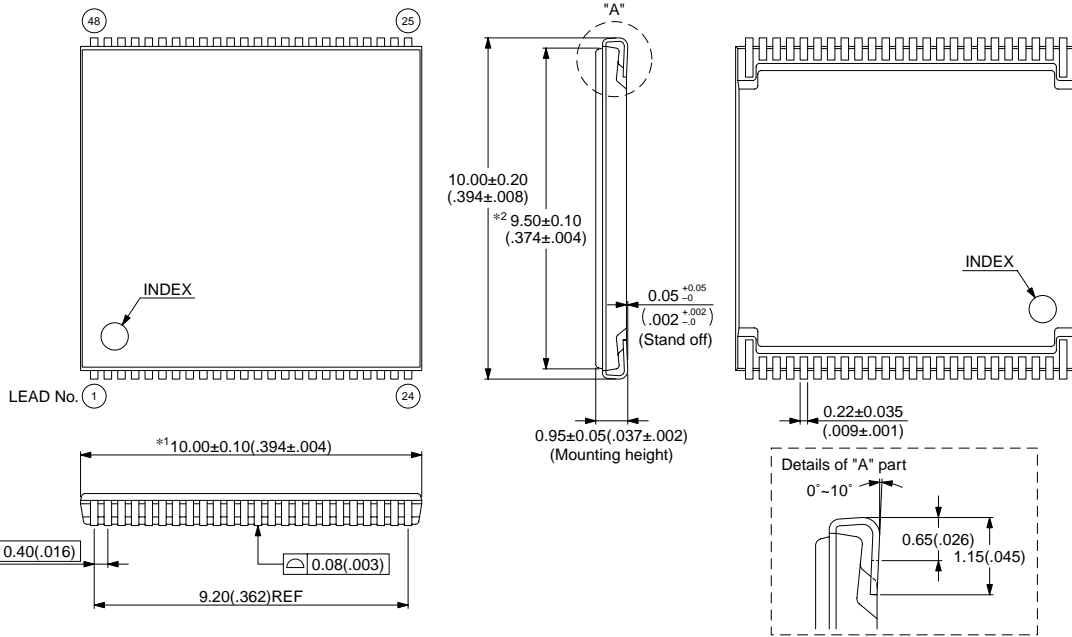

© 2003 FUJITSU LIMITED C48056S-c-2-2

Dimensions in mm (inches)

Note : The values in parentheses are reference values.

(Continued)

MBM29LV160T-80/-90/-12/MBM29LV160B-80/-90/-12

(Continued)

48-ball plastic FBGA
(BGA-48P-M13)

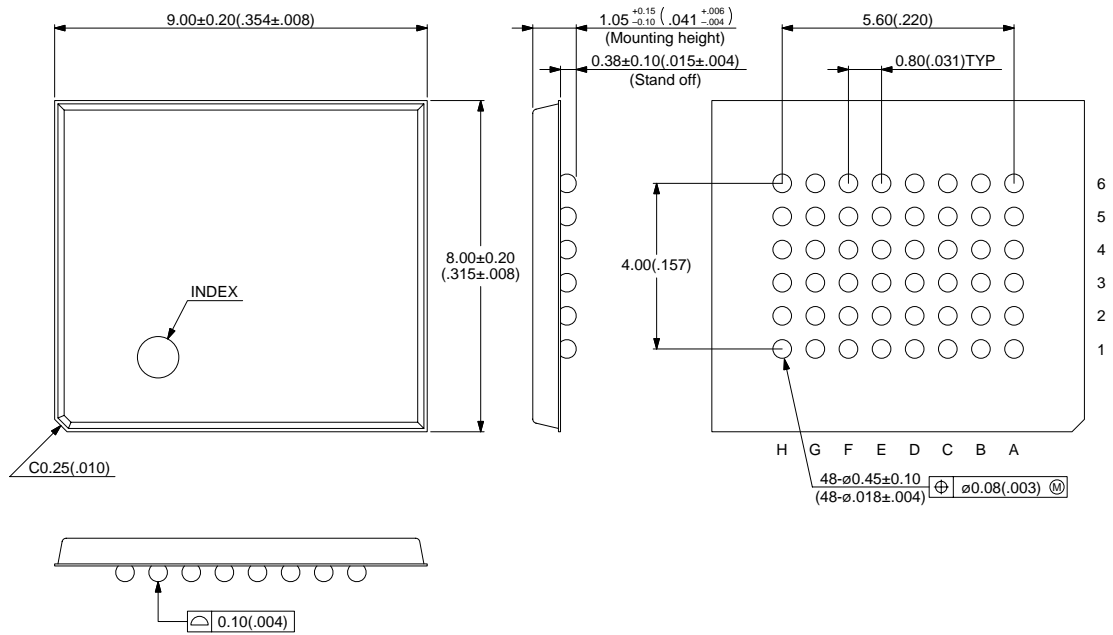

© 2001 FUJITSU LIMITED B48013S-c-3-2

Dimensions in mm (inches)

Note : The values in parentheses are reference values.

FUJITSU LIMITED

All Rights Reserved.

The contents of this document are subject to change without notice. Customers are advised to consult with FUJITSU sales representatives before ordering.

The information, such as descriptions of function and application circuit examples, in this document are presented solely for the purpose of reference to show examples of operations and uses of Fujitsu semiconductor device; Fujitsu does not warrant proper operation of the device with respect to use based on such information. When you develop equipment incorporating the device based on such information, you must assume any responsibility arising out of such use of the information. Fujitsu assumes no liability for any damages whatsoever arising out of the use of the information.

Any information in this document, including descriptions of function and schematic diagrams, shall not be construed as license of the use or exercise of any intellectual property right, such as patent right or copyright, or any other right of Fujitsu or any third party or does Fujitsu warrant non-infringement of any third-party's intellectual property right or other right by using such information. Fujitsu assumes no liability for any infringement of the intellectual property rights or other rights of third parties which would result from the use of information contained herein.

The products described in this document are designed, developed and manufactured as contemplated for general use, including without limitation, ordinary industrial use, general office use, personal use, and household use, but are not designed, developed and manufactured as contemplated (1) for use accompanying fatal risks or dangers that, unless extremely high safety is secured, could have a serious effect to the public, and could lead directly to death, personal injury, severe physical damage or other loss (i.e., nuclear reaction control in nuclear facility, aircraft flight control, air traffic control, mass transport control, medical life support system, missile launch control in weapon system), or (2) for use requiring extremely high reliability (i.e., submersible repeater and artificial satellite).

Please note that Fujitsu will not be liable against you and/or any third party for any claims or damages arising in connection with above-mentioned uses of the products.

Any semiconductor devices have an inherent chance of failure. You must protect against injury, damage or loss from such failures by incorporating safety design measures into your facility and equipment such as redundancy, fire protection, and prevention of over-current levels and other abnormal operating conditions.

If any products described in this document represent goods or technologies subject to certain restrictions on export under the Foreign Exchange and Foreign Trade Law of Japan, the prior authorization by Japanese government will be required for export of those products from Japan.