

### Miniature Relay for Signal Circuits

- Wide switching power of 10  $\mu$ A to 2 A.
- High dielectric strength coil-contacts: 1,000 VAC; open contacts: 750 VAC.
- Conforms to FCC Part 68 requirements.
- Ag + Au clad bifurcated crossbar contacts and fully sealed for high contact reliability.
- New 150-mW relays with high-sensitivity.

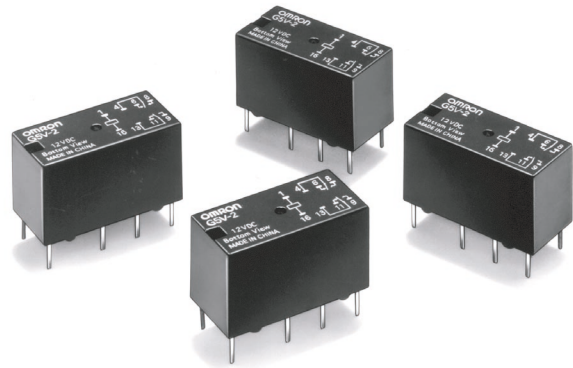

### Ordering Information

Classification	Contact form	Contact type	Contact material	Enclosure ratings	Model
Standard	DPDT	Bifurcated crossbar	Ag + Au-clad	Fully sealed	G5V-2
High-sensitivity					G5V-2-H1

**Note:** When ordering, add the rated coil voltage to the model number.

Example: G5V-2 12 VDC

Rated coil voltage

#### Model Number Legend

G5V -    -       VDC  
           1   2   3

1. **Contact Form**  
 2: DPDT

2. **Classification**  
 H1: High-sensitivity

3. **Rated Coil Voltage**  
 3, 5, 6, 9, 12, 24, 48 VDC

### Specifications

#### ■ Coil Ratings

##### Standard Models

Rated voltage	3 VDC	5 VDC	6 VDC	9 VDC	12 VDC	24 VDC	48 VDC
Rated current	166.7 mA	100 mA	83.3 mA	55.6 mA	41.7 mA	20.8 mA	12 mA
Coil resistance	18 $\Omega$	50 $\Omega$	72 $\Omega$	162 $\Omega$	288 $\Omega$	1,152 $\Omega$	4,000 $\Omega$
Coil inductance (H) (ref. value)	Armature OFF	0.04	0.09	0.16	0.31	0.47	7.23
	Armature ON	0.05	0.11	0.19	0.49	0.74	10.00
Must operate voltage	75% max. of rated voltage						
Must release voltage	5% min. of rated voltage						
Max. voltage	120% of rated voltage at 23°C						
Power consumption	Approx. 500 mW						Approx. 580 mW

## High Sensitivity Models

Rated voltage	3 VDC	5 VDC	6 VDC	9 VDC	12 VDC	24 VDC	48 VDC
Rated current	50 mA	30 mA	25 mA	16.7 mA	12.5 mA	8.33 mA	6.25 mA
Coil resistance	60 $\Omega$	166.7 $\Omega$	240 $\Omega$	540 $\Omega$	960 $\Omega$	2,880 $\Omega$	7,680 $\Omega$
Coil inductance (H) (ref. value)	Armature ON	0.18	0.46	0.70	1.67	2.90	6.72
	Armature OFF	0.57	0.71	0.97	2.33	3.99	9.27
Must operate voltage	75% max. of rated voltage						
Must release voltage	5% min. of rated voltage						
Max. voltage	180% of rated voltage at 23°C						150% of rated voltage at 23°C
Power consumption	Approx. 150 mW				Approx. 200 mW		Approx. 300 mW

- Note: 1. The rated current and coil resistance are measured at a coil temperature of 23°C with a tolerance of  $\pm 10\%$ .  
2. Operating characteristics are measured at a coil temperature of 23°C.

## ■ Contact Ratings

Item	Standard models	High sensitivity models
Load	Resistive load ( $\cos\phi = 1$ )	
Rated load	0.5 A at 125 VAC; 2 A at 30 VDC	0.5 A at 125 VAC; 1 A at 24 VDC
Contact material	Ag + Au-clad	
Rated carry current	2 A	
Max. switching voltage	125 VAC, 125 VDC	
Max. switching current	2 A	1 A
Max. switching power	62.5 VA, 60 W	62.5 VA, 24 W
Failure rate (reference value)	0.01 mA at 10 mVDC	

Note Note:P level:  $\lambda_{60} = 0.1 \times 10^{-6}/\text{operation}$

## ■ Characteristics

Item	Standard models	High sensitivity models
Contact resistance	50 m $\Omega$ max.	100 m $\Omega$ max.
Operate time	7 ms max.	
Release time	3 ms max.	
Bounce time	Operate: approx. 0.3 ms Release: approx. 1.5 ms	
Max. operating frequency	Mechanical: 36,000 operations/hr Electrical: 1,800 operations/hr (under rated load)	
Insulation resistance	1,000 M $\Omega$ min. (at 500 VDC)	
Dielectric strength	1,000 VAC, 50/60 Hz for 1 min between coil and contacts 1,000 VAC, 50/60 Hz for 1 min between contacts of different polarity 750 VAC, 50/60 Hz for 1 min between contacts of same polarity	1,000 VAC, 50/60 Hz for 1 min between coil and contacts 1,000 VAC, 50/60 Hz for 1 min between contacts of different polarity 500 VAC, 50/60 Hz for 1 min between contacts of same polarity
Impulse withstand voltage	1,500 V (10 x 160 $\mu$ s) between coil and contacts (conforms to FCC Part 68)	
Vibration resistance	Destruction: 10 to 55 to 10 Hz, 0.75-mm single amplitude (1.5-mm double amplitude) Malfunction: 10 to 55 to 10 Hz, 0.75-mm single amplitude (1.5-mm double amplitude)	
Shock resistance	Destruction: 1,000 m/s <sup>2</sup> (approx. 100G) Malfunction: 200 m/s <sup>2</sup> (approx. 20G)	Destruction: 1,000 m/s <sup>2</sup> (approx. 100G) Malfunction: 100 m/s <sup>2</sup> (approx. 10G)
Endurance	Mechanical: 15,000,000 operations min. (at 36,000 operations/hr) Electrical: 100,000 operations min. (at 1,800 operations/hr)	
Ambient temperature	Operating: -25°C to 65°C (with no icing)	Operating: -25°C to 70°C (with no icing)
Ambient humidity	Operating: 5% to 85%	
Weight	Approx. 5 g	

■ Approved Standards

UL478, UL1950, UL508 (File No. E41515)/CSA C22.2 No.0, No.14 (File No. LR24825)

Contact form	Coil ratings	Contact ratings	
		G5V-2	G5V-2-H1
DPDT	3 to 48 VDC	0.6 A, 125 VAC (general use) 0.6 A, 110 VDC (resistive load) 2 A, 30 VDC (resistive load)	0.5 A, 125 VAC (general use) 0.2 A, 110 VDC (resistive load) 1 A, 24 VDC (resistive load)

Engineering Data

Maximum Switching Power  
G5V-2

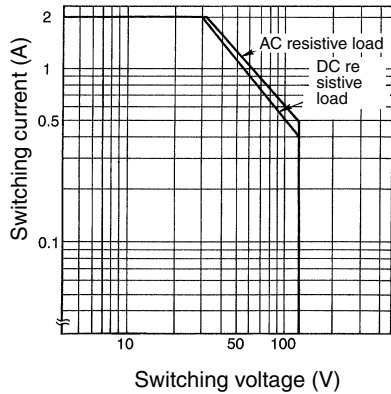

Endurance  
G5V-2

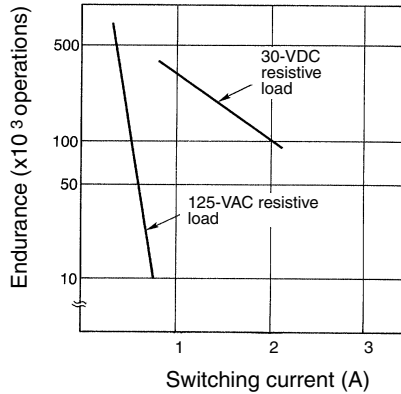

Ambient Temperature vs.  
Maximum Coil Voltage  
G5V-2

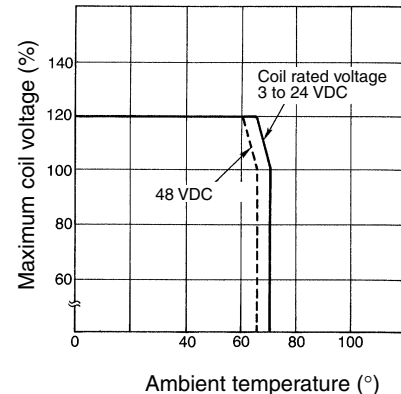

**Note:** The maximum coil voltage refers to the maximum value in a varying range of operating power voltage, not a continuous voltage.

G5V-2-H1

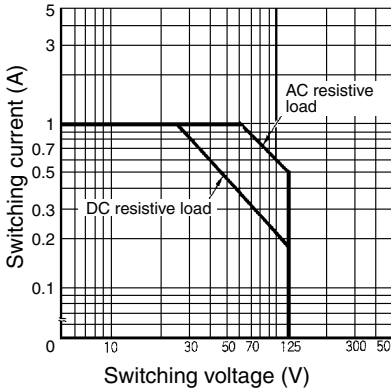

G5V-2-H1

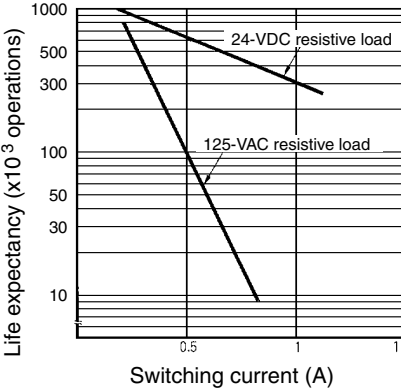

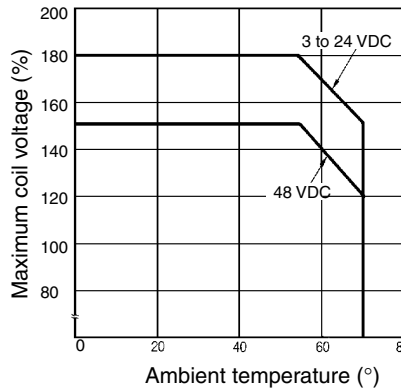

G5V-2-H1



**Note:** The maximum coil voltage refers to the maximum value in a varying range of operating power voltage, not a continuous voltage.

# Dimensions

- Note:** 1. All units are in millimeters unless otherwise indicated.  
 2. Orientation marks are indicated as follows:  

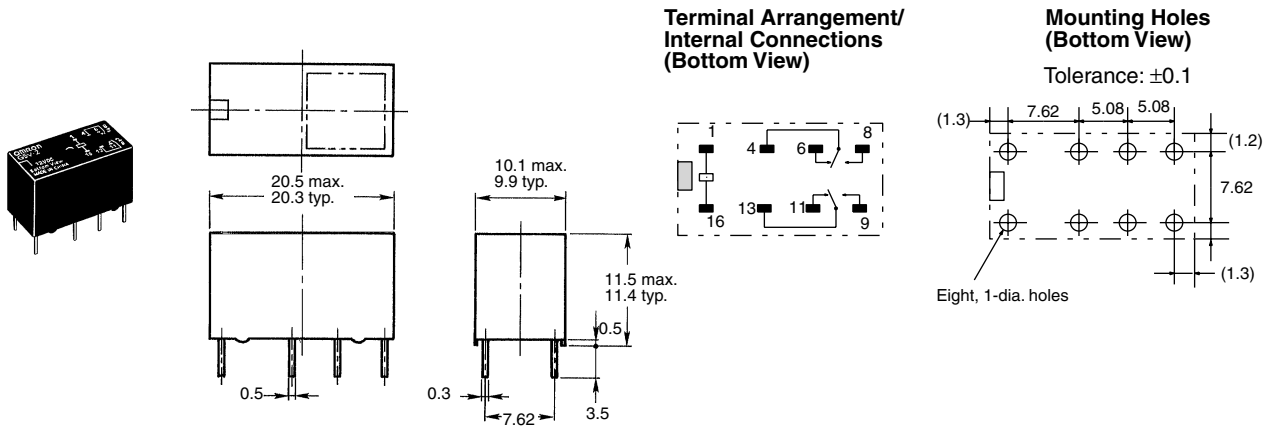

**ALL DIMENSIONS SHOWN ARE IN MILLIMETERS.**

To convert millimeters into inches, multiply by 0.03937. To convert grams into ounces, multiply by 0.03527.