

IS41C16128



128K x 16 (2-MBIT) DYNAMIC RAM WITH EDO PAGE MODE

AUGUST 1998

FEATURES

- Extended Data-Out (EDO) Page Mode access cycle
- TTL compatible inputs and outputs
- Refresh Interval: 512 cycles/8 ms
- Refresh Mode : $\overline{\text{RAS}}$ -Only, $\overline{\text{CAS}}$ -before- $\overline{\text{RAS}}$ (CBR), and Hidden
- JEDEC standard pinout
- Single +5V \pm 10% power supply
- Byte Write and Byte Read operation via two $\overline{\text{CAS}}$
- Available in 40-pin SOJ and TSOP (Type II)
- Industrial temperature available

DESCRIPTION

The *ISSI* IS41C16128 is a 131,072 x 16-bit high-performance CMOS Dynamic Random Access Memory. The IS41C16128 offers an accelerated cycle access called EDO Page Mode. EDO Page Mode allows 256 random accesses within a single row with access cycle time as short as 12 ns per 16-bit word. The Byte Write control, of upper and lower byte, makes the IS41C16128 ideal for use in 16-, 32-bit wide data bus systems.

These features make the IS41C16128 ideally suited for high band-width graphics, digital signal processing, high-performance computing systems, and peripheral applications.

The IS41C16128 is packaged in a 40-pin 400-mil SOJ and TSOP (Type II).

FUNCTIONAL BLOCK DIAGRAM

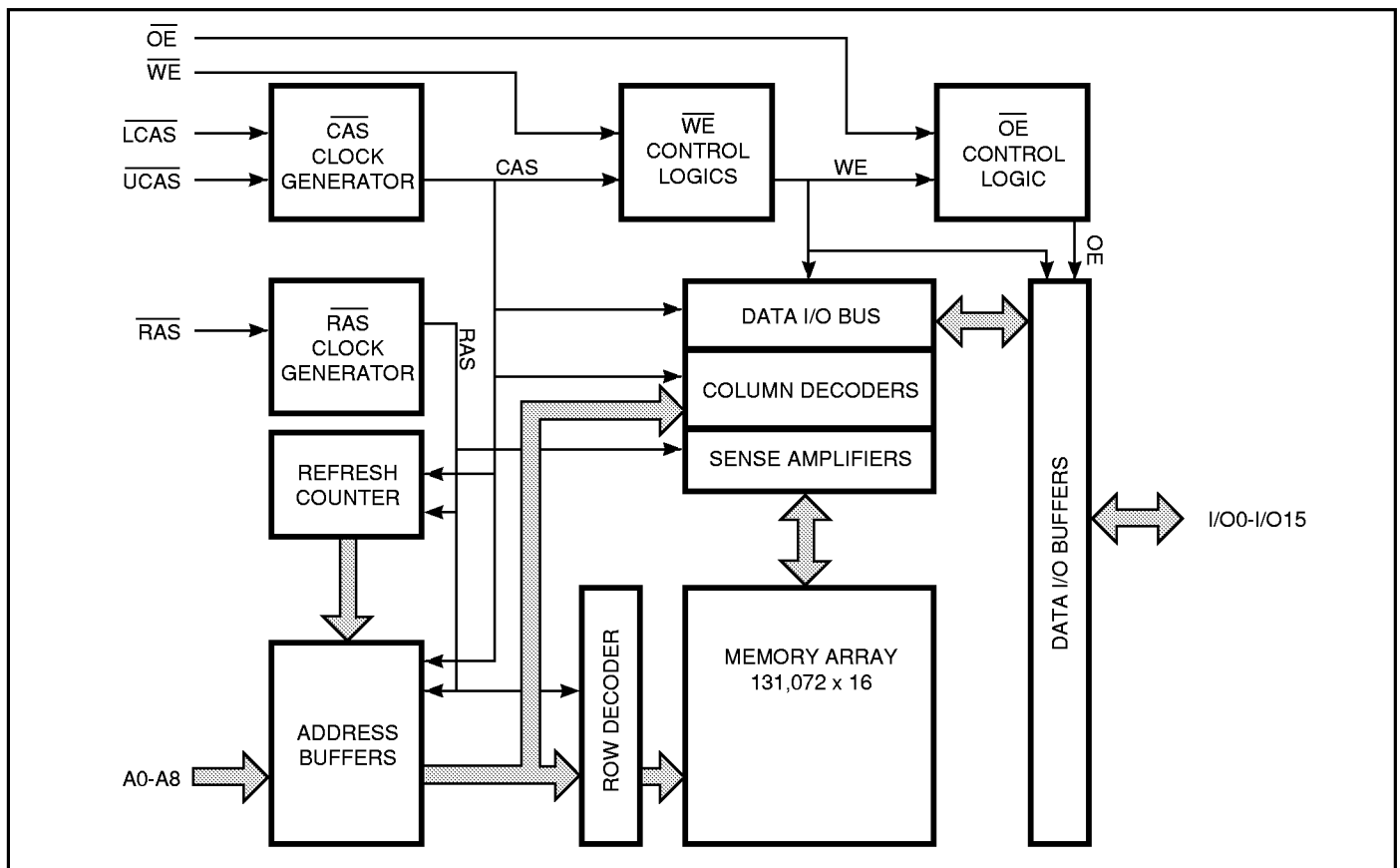

This document contains PRELIMINARY data. ISSI reserves the right to make changes to its products at any time without notice in order to improve design and supply the best possible product. We assume no responsibility for any errors which may appear in this publication. © Copyright 1998, Integrated Silicon Solution, Inc.

KEY TIMING PARAMETERS

Parameter	-35	-40	-45	-50	-60
Max. $\overline{\text{RAS}}$ Access Time (t_{RAC})	35 ns	40 ns	45 ns	50 ns	60 ns
Max. $\overline{\text{CAS}}$ Access Time (t_{CAC})	10 ns	12 ns	13 ns	14 ns	15 ns
Max. Column Address Access Time (t_{AA})	18 ns	20 ns	22 ns	25 ns	30 ns
Min. EDO Page Mode Cycle Time (t_{PC})	12 ns	15 ns	17 ns	20 ns	25 ns
Min. Read/Write Cycle Time (t_{RC})	60 ns	75 ns	80 ns	90 ns	110 ns

PIN CONFIGURATIONS

40-Pin TSOP (Type II)

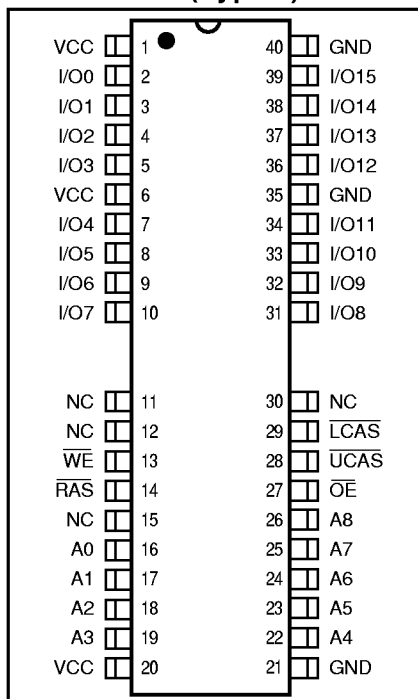

40-Pin SOJ

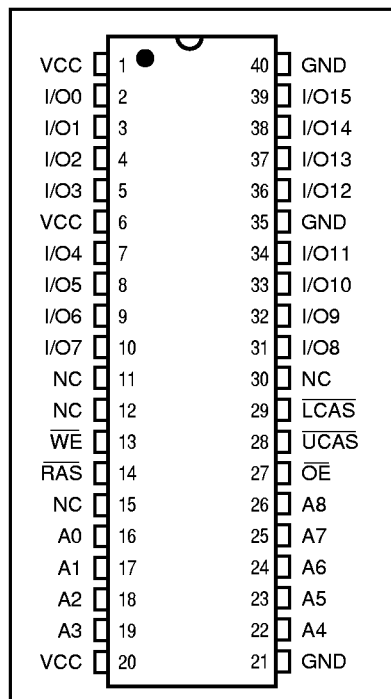

PIN DESCRIPTIONS

A0-A8	Address Inputs
I/O0-15	Data Inputs/Outputs
$\overline{\text{WE}}$	Write Enable
$\overline{\text{OE}}$	Output Enable
$\overline{\text{RAS}}$	Row Address Strobe
UCAS	Upper Column Address Strobe
LCAS	Lower Column Address Strobe
Vcc	Power
GND	Ground
NC	No Connection

TRUTH TABLE

Function	RAS	LCAS	UCAS	WE	OE	Address tr/tc	I/O	
Standby	H	H	H	X	X	X	High-Z	
Read: Word	L	L	L	H	L	ROW/COL	DOUT	
Read: Lower Byte	L	L	H	H	L	ROW/COL	Lower Byte, DOUT Upper Byte, High-Z	
Read: Upper Byte	L	H	L	H	L	ROW/COL	Lower Byte, High-Z Upper Byte, DOUT	
Write: Word (Early Write)	L	L	L	L	X	ROW/COL	DIN	
Write: Lower Byte (Early Write)	L	L	H	L	X	ROW/COL	Lower Byte, DIN Upper Byte, High-Z	
Write: Upper Byte (Early Write)	L	H	L	L	X	ROW/COL	Lower Byte, High-Z Upper Byte, DIN	
Read-Write ^(1,2)	L	L	L	H→L	L→H	ROW/COL	DOUT, DIN	
EDO Page-Mode Read ⁽²⁾	1st Cycle:	L	H→L	H→L	H	L	ROW/COL	DOUT
	2nd Cycle:	L	H→L	H→L	H	L	NA/COL	DOUT
	Any Cycle:	L	L→H	L→H	H	L	NA/NA	DOUT
EDO Page-Mode Write ⁽¹⁾	1st Cycle:	L	H→L	H→L	L	X	ROW/COL	DIN
	2nd Cycle:	L	H→L	H→L	L	X	NA/COL	DIN
EDO Page-Mode Read-Write ^(1,2)	1st Cycle:	L	H→L	H→L	H→L	L→H	ROW/COL	DOUT, DIN
	2nd Cycle:	L	H→L	H→L	H→L	L→H	NA/COL	DOUT, DIN
Hidden Refresh ⁽²⁾	Read	L→H→L	L	L	H	L	ROW/COL	DOUT
	Write	L→H→L	L	L	L	X	ROW/COL	DOUT
RAS-Only Refresh	L	H	H	X	X	ROW/NA	High-Z	
CBR Refresh ⁽³⁾	H→L	L	L	X	X	X	High-Z	

Notes:

1. These WRITE cycles may also be BYTE WRITE cycles (either \overline{LCAS} or \overline{UCAS} active).
2. These READ cycles may also be BYTE READ cycles (either \overline{LCAS} or \overline{UCAS} active).
3. At least one of the two CAS signals must be active (\overline{LCAS} or \overline{UCAS}).

Functional Description

The IS41C16128 is a CMOS DRAM optimized for high-speed bandwidth, low power applications. During READ or WRITE cycles, each bit is uniquely addressed through the 17 address bits. The row address is latched by the Row Address Strobe (\overline{RAS}). The column address is latched by the Column Address Strobe (\overline{CAS}). \overline{RAS} is used to latch the first nine bits and \overline{CAS} is used to latch the latter nine bits.

The IS41C16128 has two \overline{CAS} controls, \overline{LCAS} and \overline{UCAS} . The \overline{LCAS} and \overline{UCAS} inputs internally generates a \overline{CAS} signal functioning in an identical manner to the single \overline{CAS} input on the other 128K x 16 DRAMs. The key difference is that each \overline{CAS} controls its corresponding I/O tristate logic (in conjunction with \overline{OE} and \overline{WE} and \overline{RAS}). \overline{LCAS} controls I/O0 through I/O7 and \overline{UCAS} controls I/O8 through I/O15.

The IS41C16128 \overline{CAS} function is determined by the first \overline{CAS} (\overline{LCAS} or \overline{UCAS}) transitioning LOW and the last transitioning back HIGH. The two \overline{CAS} controls give the IS41C16128 both BYTE READ and BYTE WRITE cycle capabilities.

Memory Cycle

A memory cycle is initiated by bring \overline{RAS} LOW and it is terminated by returning both \overline{RAS} and \overline{CAS} HIGH. To ensure proper device operation and data integrity any memory cycle, once initiated, must not be ended or aborted before the minimum t_{RAS} time has expired. A new cycle must not be initiated until the minimum precharge time t_{RP} , t_{CP} has elapsed.

Read Cycle

A read cycle is initiated by the falling edge of \overline{CAS} or \overline{OE} , whichever occurs last, while holding \overline{WE} HIGH. The column address must be held for a minimum time specified by t_{AR} . Data Out becomes valid only when t_{RAC} , t_{AA} , t_{CAC} and t_{OEA} are all satisfied. As a result, the access time is dependent on the timing relationships between these parameters.

Write Cycle

A write cycle is initiated by the falling edge of \overline{CAS} and \overline{WE} , whichever occurs last. The input data must be valid at or before the falling edge of \overline{CAS} or \overline{WE} , whichever occurs last.

Refresh Cycle

To retain data, 512 refresh cycles are required in each 8 ms period. There are two ways to refresh the memory.

1. By clocking each of the 512 row addresses (A0 through A8) with \overline{RAS} at least once every 8 ms. Any read, write, read-modify-write or \overline{RAS} -only cycle refreshes the addressed row.
2. Using a \overline{CAS} -before- \overline{RAS} refresh cycle. \overline{CAS} -before- \overline{RAS} refresh is activated by the falling edge of \overline{RAS} , while holding \overline{CAS} LOW. In \overline{CAS} -before- \overline{RAS} refresh cycle, an internal 9-bit counter provides the row addresses and the external address inputs are ignored.

\overline{CAS} -before- \overline{RAS} is a refresh-only mode and no data access or device selection is allowed. Thus, the output remains in the High-Z state during the cycle.

Extended Data Out Page Mode

EDO page mode operation permits all 256 columns within a selected row to be randomly accessed at a high data rate.

In EDO page mode read cycle, the data-out is held to the next \overline{CAS} cycle's falling edge, instead of the rising edge. For this reason, the valid data output time in EDO page mode is extended compared with the fast page mode. In the fast page mode, the valid data output time becomes shorter as the \overline{CAS} cycle time becomes shorter. Therefore, in EDO page mode, the timing margin in read cycle is larger than that of the fast page mode even if the \overline{CAS} cycle time becomes shorter.

In EDO page mode, due to the extended data function, the \overline{CAS} cycle time can be shorter than in the fast page mode if the timing margin is the same.

The EDO page mode allows both read and write operations during one \overline{RAS} cycle, but the performance is equivalent to that of the fast page mode in that case.

Power-On

After application of the V_{CC} supply, an initial pause of 200 μ s is required followed by a minimum of eight initialization cycles (any combination of cycles containing a \overline{RAS} signal).

During power-on, it is recommended that \overline{RAS} track with V_{CC} or be held at a valid V_{IH} to avoid current surges.

ABSOLUTE MAXIMUM RATINGS⁽¹⁾

Symbol	Parameters		Rating	Unit
V _T	Voltage on Any Pin Relative to GND		-1.0 to +7.0	V
V _{CC}	Supply Voltage		-1.0 to +7.0	V
I _{OUT}	Output Current		50	mA
P _D	Power Dissipation		1	W
T _A	Operation Temperature	Com.	0 to +70	°C
		Ind.	-40 to +85	
T _{STG}	Storage Temperature		-55 to +125	°C

Note:

1. Stress greater than those listed under ABSOLUTE MAXIMUM RATINGS may cause permanent damage to the device. This is a stress rating only and functional operation of the device at these or any other conditions above those indicated in the operational sections of this specification is not implied. Exposure to absolute maximum rating conditions for extended periods may affect reliability.

RECOMMENDED OPERATING CONDITIONS (Voltages are referenced to GND.)

Symbol	Parameter		Min.	Typ.	Max.	Unit
V _{CC}	Supply Voltage		4.5	5.0	5.5	V
V _{IH}	Input High Voltage		2.4	—	V _{CC} + 1.0	V
V _{IL}	Input Low Voltage		-1.0	—	+0.8	V
T _A	Ambient Temperature	Com.	0	—	+70	°C
		Ind.	-40	—	+85	

CAPACITANCE^(1,2)

Symbol	Parameter		Max.	Unit
C _{IN1}	Input Capacitance: A0-A8		5	pF
C _{IN2}	Input Capacitance: $\overline{\text{RAS}}$, UCAS, LCAS, WE, OE		7	pF
C _{IO}	Data Input/Output Capacitance: I/O0-I/O15		7	pF

Notes:

1. Tested initially and after any design or process changes that may affect these parameters.
2. Test conditions: T_A = 25°C, f = 1 MHz, V_{CC} = 5.0V ± 10%.

ELECTRICAL CHARACTERISTICS⁽¹⁾ (Recommended Operation Conditions unless otherwise noted.)

Symbol	Parameter	Test Condition	Speed	Min.	Max.	Unit
I _{IL}	Input Leakage Current	Any input $0V \leq V_{IN} \leq 5.5V$ Other inputs not under test = 0V		-10	10	μA
I _{IO}	Output Leakage Current	Output is disabled (Hi-Z) $0V \leq V_{OUT} \leq 5.5V$		-10	10	μA
V _{OH}	Output High Voltage Level	I _{OH} = -2.5 mA		2.4	—	V
V _{OL}	Output Low Voltage Level	I _{OL} = +2.1 mA		—	0.4	V
I _{CC1}	Stand-by Current: TTL	$\overline{RAS}, \overline{LCAS}, \overline{UCAS} \geq V_{IH}$		—	2	mA
I _{CC2}	Stand-by Current: CMOS	$\overline{RAS}, \overline{LCAS}, \overline{UCAS} \geq V_{CC} - 0.2V$		—	1	mA
I _{CC3}	Operating Current: Random Read/Write ^(2,3,4) Average Power Supply Current	$\overline{RAS}, \overline{LCAS}, \overline{UCAS}$, Address Cycling, t _{RC} = t _{RC} (min.)	-35	—	230	mA
			-40	—	130	
			-45	—	120	
			-50	—	110	
			-60	—	100	
I _{CC4}	Operating Current: EDO Page Mode ^(2,3,4) Average Power Supply Current	$\overline{RAS} = V_{IL}, \overline{LCAS}, \overline{UCAS}$, Cycling t _{PC} = t _{PC} (min.)	-35	—	220	mA
			-40	—	90	
			-45	—	85	
			-50	—	80	
			-60	—	70	
I _{CC5}	Refresh Current: \overline{RAS} -Only ^(2,3) Average Power Supply Current	\overline{RAS} Cycling, $\overline{LCAS}, \overline{UCAS} \geq V_{IH}$ t _{RC} = t _{RC} (min.)	-35	—	230	mA
			-40	—	130	
			-45	—	120	
			-50	—	100	
			-60	—	100	
I _{CC6}	Refresh Current: CBR ^(2,3,5) Average Power Supply Current	$\overline{RAS}, \overline{LCAS}, \overline{UCAS}$ Cycling t _{RC} = t _{RC} (min.)	-35	—	230	mA
			-40	—	130	
			-45	—	120	
			-50	—	100	
			-60	—	100	

Notes:

1. An initial pause of 200 μs is required after power-up followed by eight \overline{RAS} refresh cycles (\overline{RAS} -Only or CBR) before proper device operation is assured. The eight \overline{RAS} cycles wake-up should be repeated any time the t_{REF} refresh requirement is exceeded.
2. Dependent on cycle rates.
3. Specified values are obtained with minimum cycle time and the output open.
4. Column-address is changed once each EDO page cycle.
5. Enables on-chip refresh and address counters.

AC CHARACTERISTICS^(1,2,3,4,5,6) (Recommended Operating Conditions unless otherwise noted.)

Symbol	Parameter	-35		-40		-45		-50		-60		Units
		Min.	Max.	Min.	Max.	Min.	Max.	Min.	Max.	Min.	Max.	
t _{RC}	Random READ or WRITE Cycle Time	60	—	75	—	80	—	90	—	110	—	ns
t _{TRAC}	Access Time from $\overline{\text{RAS}}$ ^(6, 7)	—	35	—	40	—	45	—	50	—	60	ns
t _{CAC}	Access Time from $\overline{\text{CAS}}$ ^(6, 8, 15)	—	10	—	12	—	13	—	14	—	15	ns
t _{AA}	Access Time from Column-Address ⁽⁶⁾	—	18	—	20	—	22	—	25	—	30	ns
t _{TRAS}	$\overline{\text{RAS}}$ Pulse Width	35	10K	40	10K	45	10K	50	10K	60	10K	ns
t _{RP}	$\overline{\text{RAS}}$ Precharge Time	20	—	25	—	25	—	30	—	40	—	ns
t _{CAS}	$\overline{\text{CAS}}$ Pulse Width ⁽²⁶⁾	6	10K	6	10K	7	10K	8	10K	10	10K	ns
t _{CP}	$\overline{\text{CAS}}$ Precharge Time ^(9, 25)	5	—	5	—	7	—	8	—	10	—	ns
t _{CSH}	$\overline{\text{CAS}}$ Hold Time ⁽²¹⁾	35	—	40	—	45	—	50	—	60	—	ns
t _{RCD}	$\overline{\text{RAS}}$ to $\overline{\text{CAS}}$ Delay Time ^(10, 20)	11	28	17	28	18	32	19	36	20	45	ns
t _{ASR}	Row-Address Setup Time	0	—	0	—	0	—	0	—	0	—	ns
t _{RAH}	Row-Address Hold Time	6	—	6	—	7	—	8	—	10	—	ns
t _{ASC}	Column-Address Setup Time ⁽²⁰⁾	0	—	0	—	0	—	0	—	0	—	ns
t _{CAH}	Column-Address Hold Time ⁽²⁰⁾	6	—	6	—	7	—	8	—	10	—	ns
t _{AR}	Column-Address Hold Time (referenced to $\overline{\text{RAS}}$)	30	—	30	—	35	—	40	—	40	—	ns
t _{RAD}	$\overline{\text{RAS}}$ to Column-Address Delay Time ⁽¹¹⁾	12	20	12	20	13	22	14	25	15	30	ns
t _{RAL}	Column-Address to $\overline{\text{RAS}}$ Lead Time	18	—	20	—	22	—	25	—	30	—	ns
t _{RPC}	$\overline{\text{RAS}}$ to $\overline{\text{CAS}}$ Precharge Time	0	—	0	—	0	—	0	—	0	—	ns
t _{RSH}	$\overline{\text{RAS}}$ Hold Time ⁽²⁷⁾	8	—	12	—	13	—	14	—	15	—	ns
t _{CLZ}	$\overline{\text{CAS}}$ to Output in Low-Z ^(15, 29)	3	—	3	—	3	—	3	—	3	—	ns
t _{CRP}	$\overline{\text{CAS}}$ to $\overline{\text{RAS}}$ Precharge Time ⁽²¹⁾	5	—	5	—	5	—	5	—	5	—	ns
t _{OD}	Output Disable Time ^(19, 28, 29)	3	15	3	15	3	15	3	15	3	15	ns
t _{OE}	Output Enable Time ^(15, 16)	—	10	—	10	—	12	—	15	—	15	ns
t _{OEHC}	$\overline{\text{OE}}$ HIGH Hold Time from $\overline{\text{CAS}}$ HIGH	10	—	10	—	10	—	10	—	10	—	ns
t _{OEP}	$\overline{\text{OE}}$ HIGH Pulse Width	10	—	10	—	10	—	10	—	10	—	ns
t _{OES}	$\overline{\text{OE}}$ LOW to $\overline{\text{CAS}}$ HIGH Setup Time	5	—	5	—	5	—	5	—	5	—	ns
t _{RCS}	Read Command Setup Time ^(17, 20)	0	—	0	—	0	—	0	—	0	—	ns
t _{RRH}	Read Command Hold Time (referenced to $\overline{\text{RAS}}$) ⁽¹²⁾	0	—	0	—	0	—	0	—	0	—	ns
t _{RCH}	Read Command Hold Time (referenced to $\overline{\text{CAS}}$) ^(12, 17, 21)	0	—	0	—	0	—	0	—	0	—	ns
t _{WCH}	Write Command Hold Time ^(17, 27)	5	—	6	—	7	—	8	—	10	—	ns
t _{WCR}	Write Command Hold Time (referenced to $\overline{\text{RAS}}$) ⁽¹⁷⁾	30	—	30	—	35	—	40	—	50	—	ns
t _{WP}	Write Command Pulse Width ⁽¹⁷⁾	5	—	6	—	7	—	8	—	10	—	ns
t _{WPZ}	$\overline{\text{WE}}$ Pulse Widths to Disable Outputs	10	—	10	—	10	—	10	—	10	—	ns
t _{RWL}	Write Command to $\overline{\text{RAS}}$ Lead Time ⁽¹⁷⁾	8	—	12	—	13	—	14	—	15	—	ns
t _{CWL}	Write Command to $\overline{\text{CAS}}$ Lead Time ^(17, 21)	8	—	12	—	13	—	14	—	15	—	ns
t _{WCS}	Write Command Setup Time ^(14, 17, 20)	0	—	0	—	0	—	0	—	0	—	ns
t _{DHR}	Data-in Hold Time (referenced to $\overline{\text{RAS}}$)	30	—	30	—	35	—	40	—	40	—	ns

AC CHARACTERISTICS (Continued)^(1,2,3,4,5,6) (Recommended Operating Conditions unless otherwise noted.)

Symbol	Parameter	-35		-40		-45		-50		-60		Units
		Min.	Max.	Min.	Max.	Min.	Max.	Min.	Max.	Min.	Max.	
t _{ACH}	Column-Address Setup Time to $\overline{\text{CAS}}$ Precharge during WRITE Cycle	15	—	15	—	15	—	15	—	15	—	ns
t _{OEH}	$\overline{\text{OE}}$ Hold Time from $\overline{\text{WE}}$ during READ-MODIFY-WRITE cycle ⁽¹⁸⁾	8	—	8	—	8	—	10	—	15	—	ns
t _{DS}	Data-In Setup Time ^(15, 22)	0	—	0	—	0	—	0	—	0	—	ns
t _{DH}	Data-In Hold Time ^(15, 22)	6	—	6	—	7	—	8	—	10	—	ns
t _{RWC}	READ-MODIFY-WRITE Cycle Time	80	—	100	—	115	—	125	—	140	—	ns
t _{RWD}	$\overline{\text{RAS}}$ to $\overline{\text{WE}}$ Delay Time during READ-MODIFY-WRITE Cycle ⁽¹⁴⁾	45	—	50	—	60	—	70	—	80	—	ns
t _{CWD}	$\overline{\text{CAS}}$ to $\overline{\text{WE}}$ Delay Time ^(14, 20)	25	—	30	—	32	—	34	—	36	—	ns
t _{AWD}	Column-Address to $\overline{\text{WE}}$ Delay Time ⁽¹⁴⁾	30	—	30	—	40	—	42	—	49	—	ns
t _{PC}	EDO Page Mode READ or WRITE Cycle Time ⁽²⁴⁾	12	—	15	—	17	—	20	—	25	—	ns
t _{RASP}	$\overline{\text{RAS}}$ Pulse Width in EDO Page Mode	35	100K	40	100K	45	100K	50	100K	60	100K	ns
t _{CPA}	Access Time from $\overline{\text{CAS}}$ Precharge ⁽¹⁵⁾	—	21	—	23	—	25	—	27	—	34	ns
t _{PRWC}	EDO Page Mode READ-WRITE Cycle Time ⁽²⁴⁾	40	—	45	—	46	—	47	—	56	—	ns
t _{COH}	Data Output Hold after $\overline{\text{CAS}}$ LOW	3	—	3	—	3	—	3	—	3	—	ns
t _{OFF}	Output Buffer Turn-Off Delay from $\overline{\text{CAS}}$ or $\overline{\text{RAS}}$ ^(13,15,19, 29)	3	15	3	15	3	15	3	15	3	15	ns
t _{WHZ}	Output Disable Delay from $\overline{\text{WE}}$	3	15	3	15	3	15	3	15	3	15	ns
t _{CLCH}	Last $\overline{\text{CAS}}$ going LOW to First $\overline{\text{CAS}}$ returning HIGH ⁽²³⁾	10	—	10	—	10	—	10	—	10	—	ns
t _{CSR}	$\overline{\text{CAS}}$ Setup Time (CBR REFRESH) ^(30, 20)	8	—	10	—	10	—	10	—	10	—	ns
t _{CHR}	$\overline{\text{CAS}}$ Hold Time (CBR REFRESH) ^(30, 21)	8	—	10	—	10	—	10	—	10	—	ns
t _{ORD}	$\overline{\text{OE}}$ Setup Time prior to $\overline{\text{RAS}}$ during HIDDEN REFRESH Cycle	0	—	0	—	0	—	0	—	0	—	ns
t _{REF}	Refresh Period (512 Cycles)	—	8	—	8	—	8	—	8	—	8	ms
t _I	Transition Time (Rise or Fall) ^(2, 3)	1	50	1	50	1	50	1	50	1	50	ns

Notes:

1. An initial pause of 200 μ s is required after power-up followed by eight $\overline{\text{RAS}}$ refresh cycle ($\overline{\text{RAS}}$ -Only or CBR) before proper device operation is assured. The eight $\overline{\text{RAS}}$ cycles wake-up should be repeated any time the t_{REF} refresh requirement is exceeded.
2. V_{IH} (MIN) and V_{IL} (MAX) are reference levels for measuring timing of input signals. Transition times, are measured between V_{IH} and V_{IL} (or between V_{IL} and V_{IH}) and assume to be 1 ns for all inputs.
3. In addition to meeting the transition rate specification, all input signals must transit between V_{IH} and V_{IL} (or between V_{IL} and V_{IH}) in a monotonic manner.
4. If $\overline{\text{CAS}}$ and $\overline{\text{RAS}} = V_{\text{IH}}$, data output is High-Z.
5. If $\overline{\text{CAS}} = V_{\text{IL}}$, data output may contain data from the last valid READ cycle.
6. Measured with a load equivalent to one TTL gate and 50 pF.
7. Assumes that $t_{\text{RCD}} \leq t_{\text{RCD}} (\text{MAX})$. If t_{RCD} is greater than the maximum recommended value shown in this table, t_{RAC} will increase by the amount that t_{RCD} exceeds the value shown.
8. Assumes that $t_{\text{RCD}} \geq t_{\text{RCD}} (\text{MAX})$.
9. If $\overline{\text{CAS}}$ is LOW at the falling edge of $\overline{\text{RAS}}$, data out will be maintained from the previous cycle. To initiate a new cycle and clear the data output buffer, $\overline{\text{CAS}}$ and $\overline{\text{RAS}}$ must be pulsed for t_{CP} .
10. Operation with the $t_{\text{RCD}} (\text{MAX})$ limit ensures that $t_{\text{RAC}} (\text{MAX})$ can be met. $t_{\text{RCD}} (\text{MAX})$ is specified as a reference point only; if t_{RCD} is greater than the specified $t_{\text{RCD}} (\text{MAX})$ limit, access time is controlled exclusively by t_{CAC} .
11. Operation within the $t_{\text{RAD}} (\text{MAX})$ limit ensures that $t_{\text{RCD}} (\text{MAX})$ can be met. $t_{\text{RAD}} (\text{MAX})$ is specified as a reference point only; if t_{RAD} is greater than the specified $t_{\text{RAD}} (\text{MAX})$ limit, access time is controlled exclusively by t_{AA} .
12. Either t_{RCH} or t_{RRH} must be satisfied for a READ cycle.
13. $t_{\text{OFF}} (\text{MAX})$ defines the time at which the output achieves the open circuit condition; it is not a reference to V_{OH} or V_{OL} .
14. t_{WCS} , t_{RWD} , t_{AWD} and t_{CWD} are restrictive operating parameters in LATE WRITE and READ-MODIFY-WRITE cycle only. If $t_{\text{WCS}} \geq t_{\text{WCS}} (\text{MIN})$, the cycle is an EARLY WRITE cycle and the data output will remain open circuit throughout the entire cycle. If $t_{\text{RWD}} \geq t_{\text{RWD}} (\text{MIN})$, $t_{\text{AWD}} \geq t_{\text{AWD}} (\text{MIN})$ and $t_{\text{CWD}} \geq t_{\text{CWD}} (\text{MIN})$, the cycle is a READ-WRITE cycle and the data output will contain data read from the selected cell. If neither of the above conditions is met, the state of I/O (at access time and until $\overline{\text{CAS}}$ and $\overline{\text{RAS}}$ or $\overline{\text{OE}}$ go back to V_{IH}) is indeterminate. $\overline{\text{OE}}$ held HIGH and $\overline{\text{WE}}$ taken LOW after $\overline{\text{CAS}}$ goes LOW result in a LATE WRITE ($\overline{\text{OE}}$ -controlled) cycle.
15. Output parameter (I/O) is referenced to corresponding $\overline{\text{CAS}}$ input, I/O0-I/O7 by $\overline{\text{LCAS}}$ and I/O8-I/O15 by $\overline{\text{UCAS}}$.
16. During a READ cycle, if $\overline{\text{OE}}$ is LOW then taken HIGH before $\overline{\text{CAS}}$ goes HIGH, I/O goes open. If $\overline{\text{OE}}$ is tied permanently LOW, a LATE WRITE or READ-MODIFY-WRITE is not possible.
17. Write command is defined as $\overline{\text{WE}}$ going low.
18. LATE WRITE and READ-MODIFY-WRITE cycles must have both t_{OD} and $t_{\text{OE}} (\text{HIGH})$ met ($\overline{\text{OE}}$ HIGH during WRITE cycle) in order to ensure that the output buffers will be open during the WRITE cycle. The I/Os will provide the previously written data if $\overline{\text{CAS}}$ remains LOW and $\overline{\text{OE}}$ is taken back to LOW after $t_{\text{OE}} (\text{HIGH})$ is met.
19. The I/Os are in open during READ cycles once t_{OD} or t_{OFF} occur.
20. The first $\chi\overline{\text{CAS}}$ edge to transition LOW.
21. The last $\chi\overline{\text{CAS}}$ edge to transition HIGH.
22. These parameters are referenced to $\overline{\text{CAS}}$ leading edge in EARLY WRITE cycles and $\overline{\text{WE}}$ leading edge in LATE WRITE or READ-MODIFY-WRITE cycles.
23. Last falling $\chi\overline{\text{CAS}}$ edge to first rising $\chi\overline{\text{CAS}}$ edge.
24. Last rising $\chi\overline{\text{CAS}}$ edge to next cycle's last rising $\chi\overline{\text{CAS}}$ edge.
25. Last rising $\chi\overline{\text{CAS}}$ edge to first falling $\chi\overline{\text{CAS}}$ edge.
26. Each $\chi\overline{\text{CAS}}$ must meet minimum pulse width.
27. Last $\chi\overline{\text{CAS}}$ to go LOW.
28. I/Os controlled, regardless $\overline{\text{UCAS}}$ and $\overline{\text{LCAS}}$.
29. The 3 ns minimum is a parameter guaranteed by design.
30. Enables on-chip refresh and address counters.

READ CYCLE

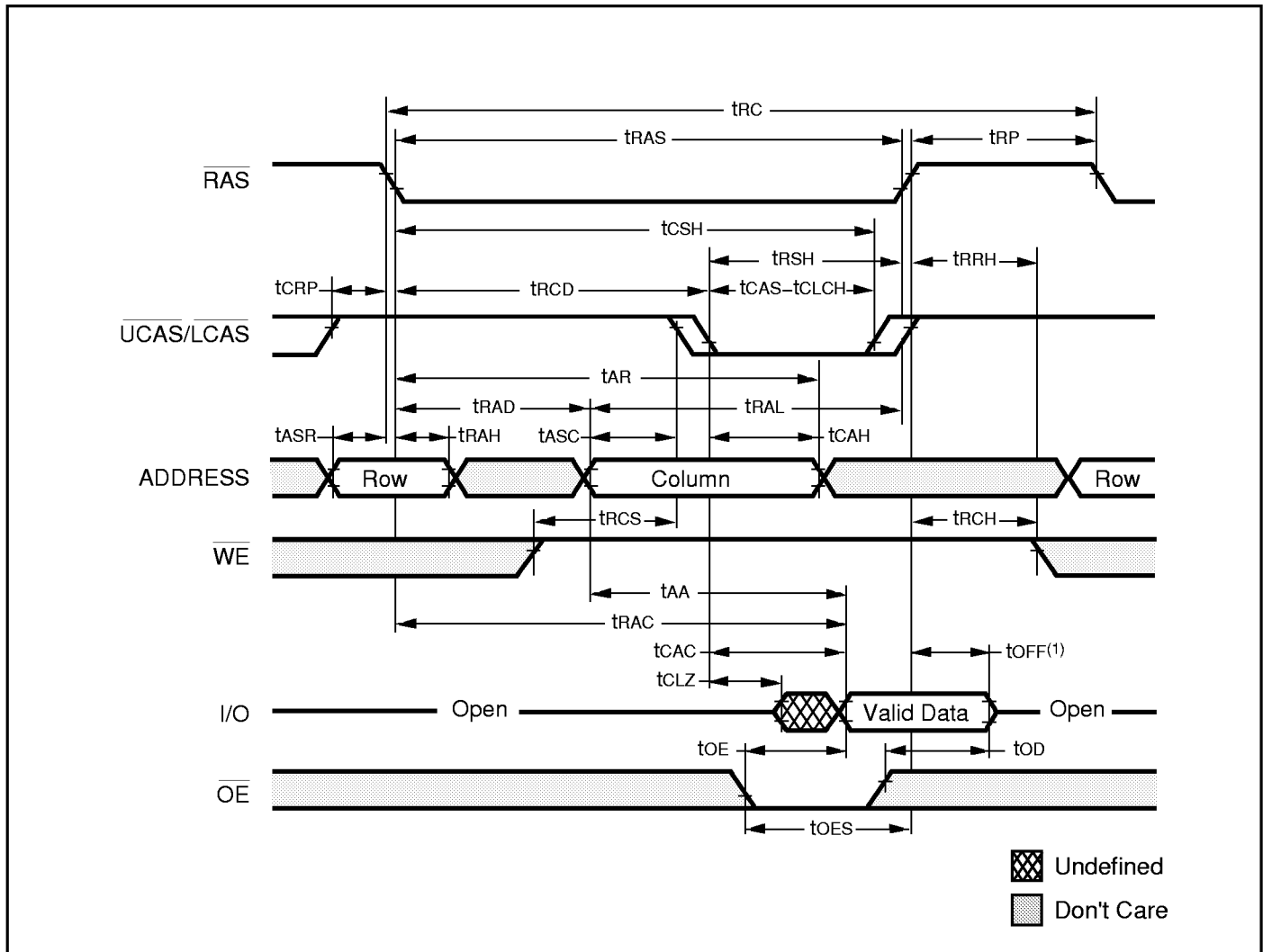

Note:

1. t_{OFF} is referenced from rising edge of \overline{RAS} or \overline{CAS} , whichever occurs last.

EARLY WRITE CYCLE ($\overline{OE} = \text{DON'T CARE}$)

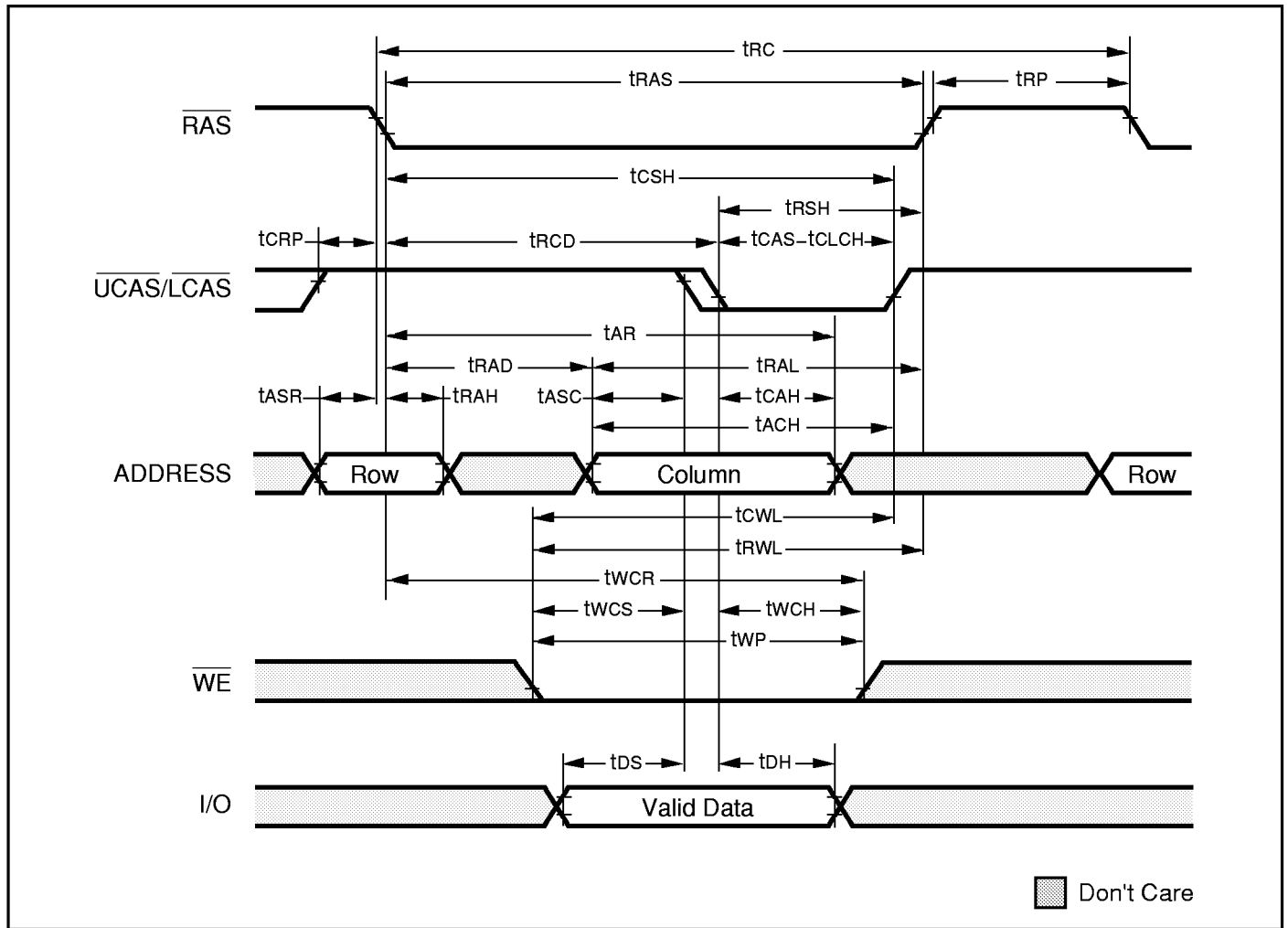

READ WRITE CYCLE (LATE WRITE and READ-MODIFY-WRITE Cycles)

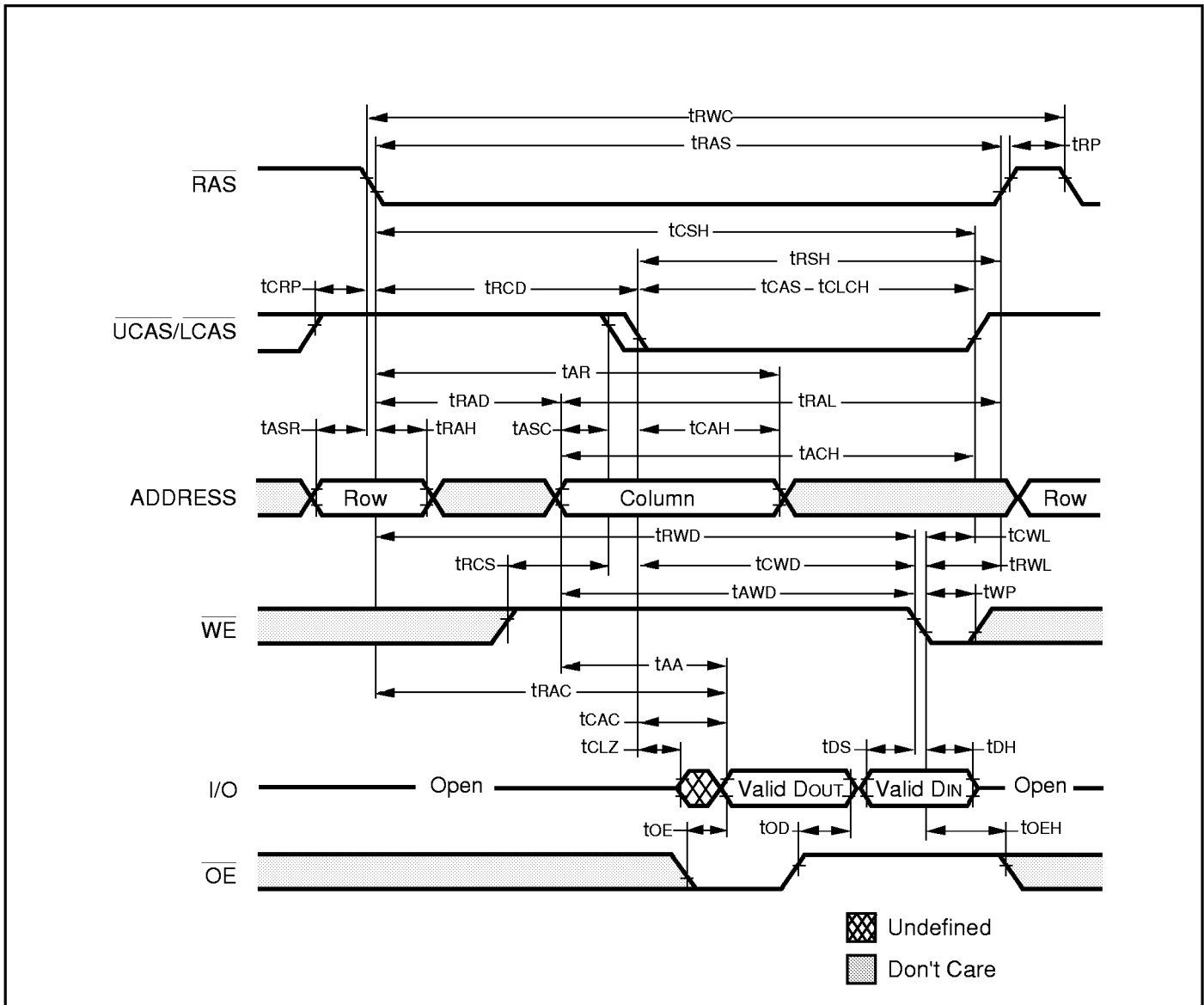

EDO-PAGE-MODE EARLY-WRITE CYCLE

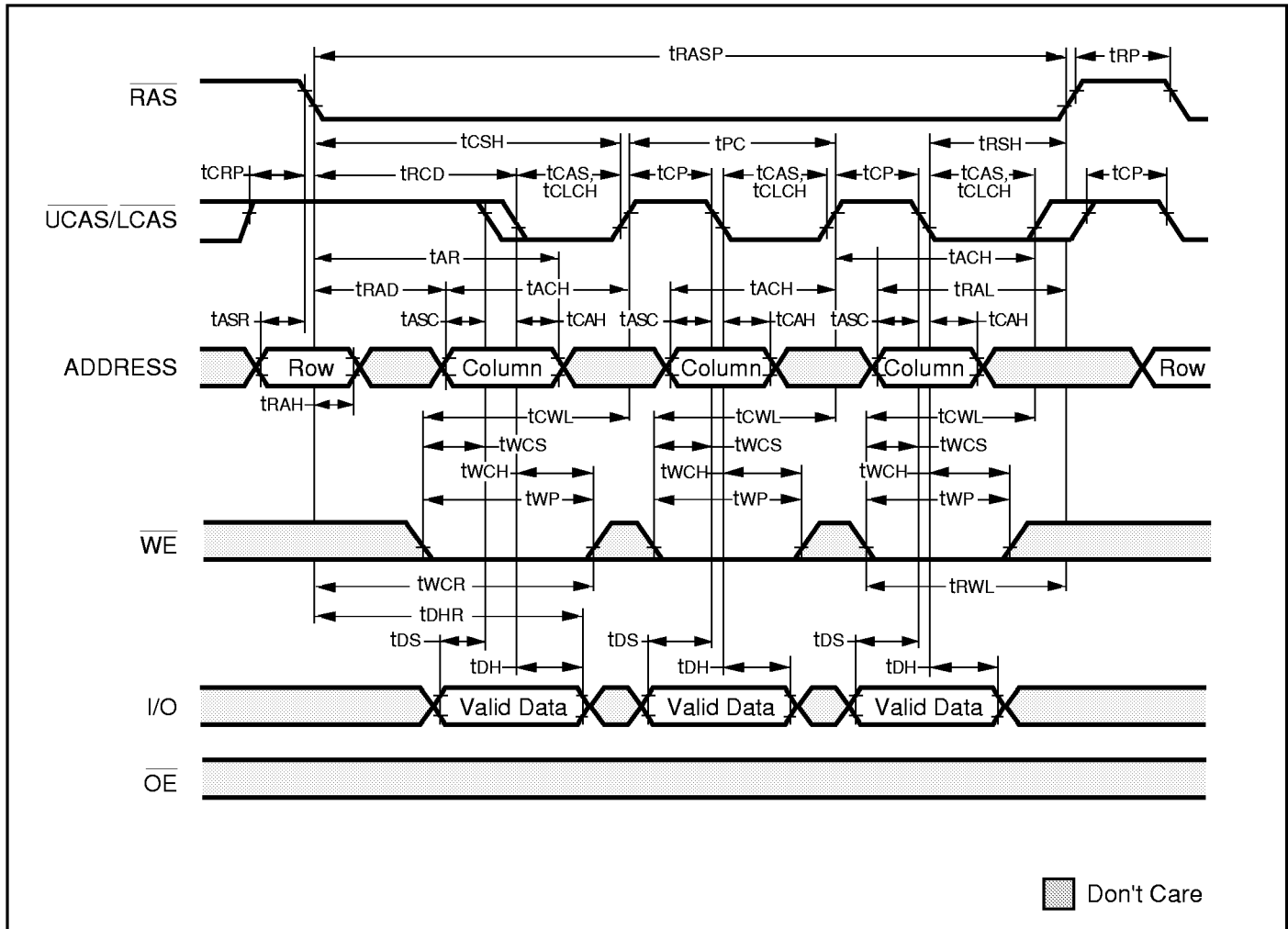

EDO-PAGE-MODE READ-EARLY-WRITE CYCLE (Psuedo READ-MODIFY WRITE)

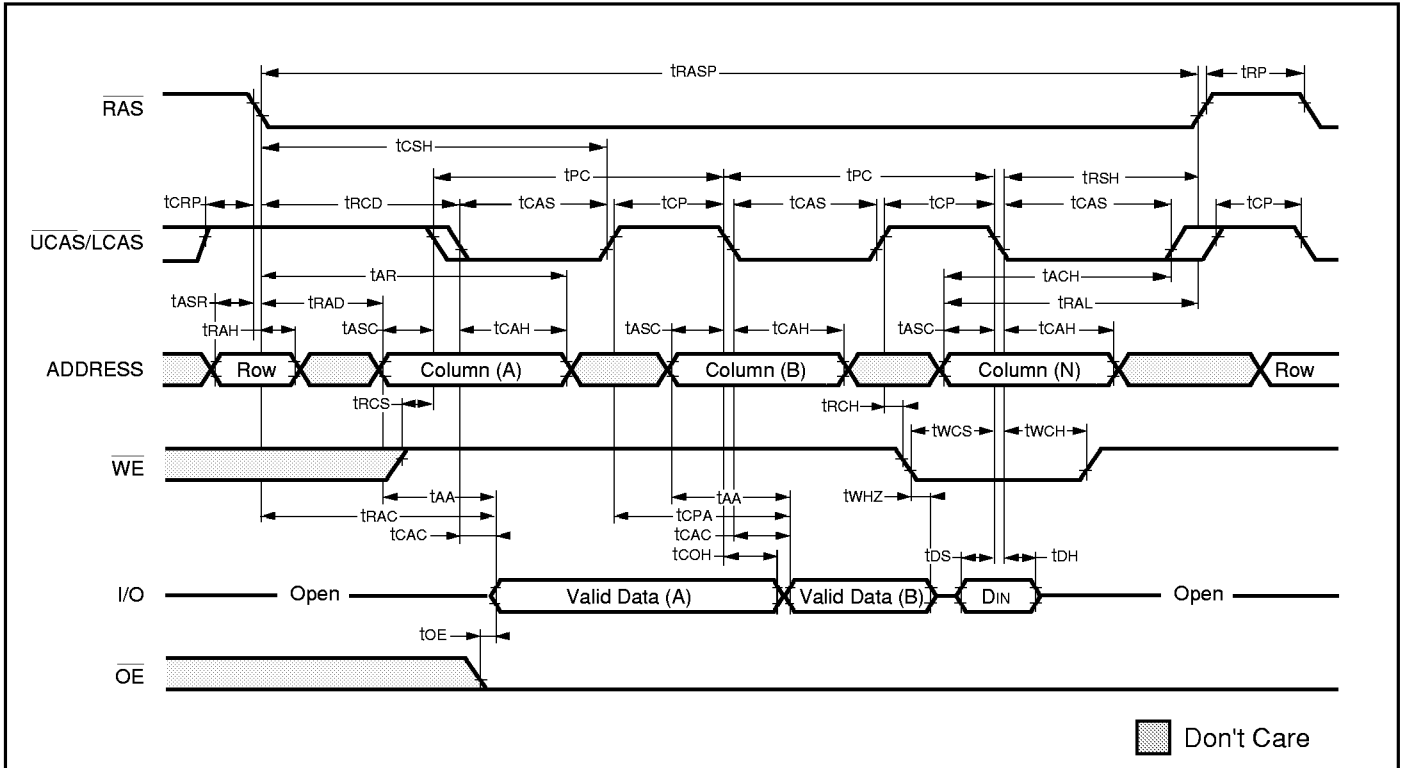

AC WAVEFORMS

READ CYCLE (With \overline{WE} -Controlled Disable)

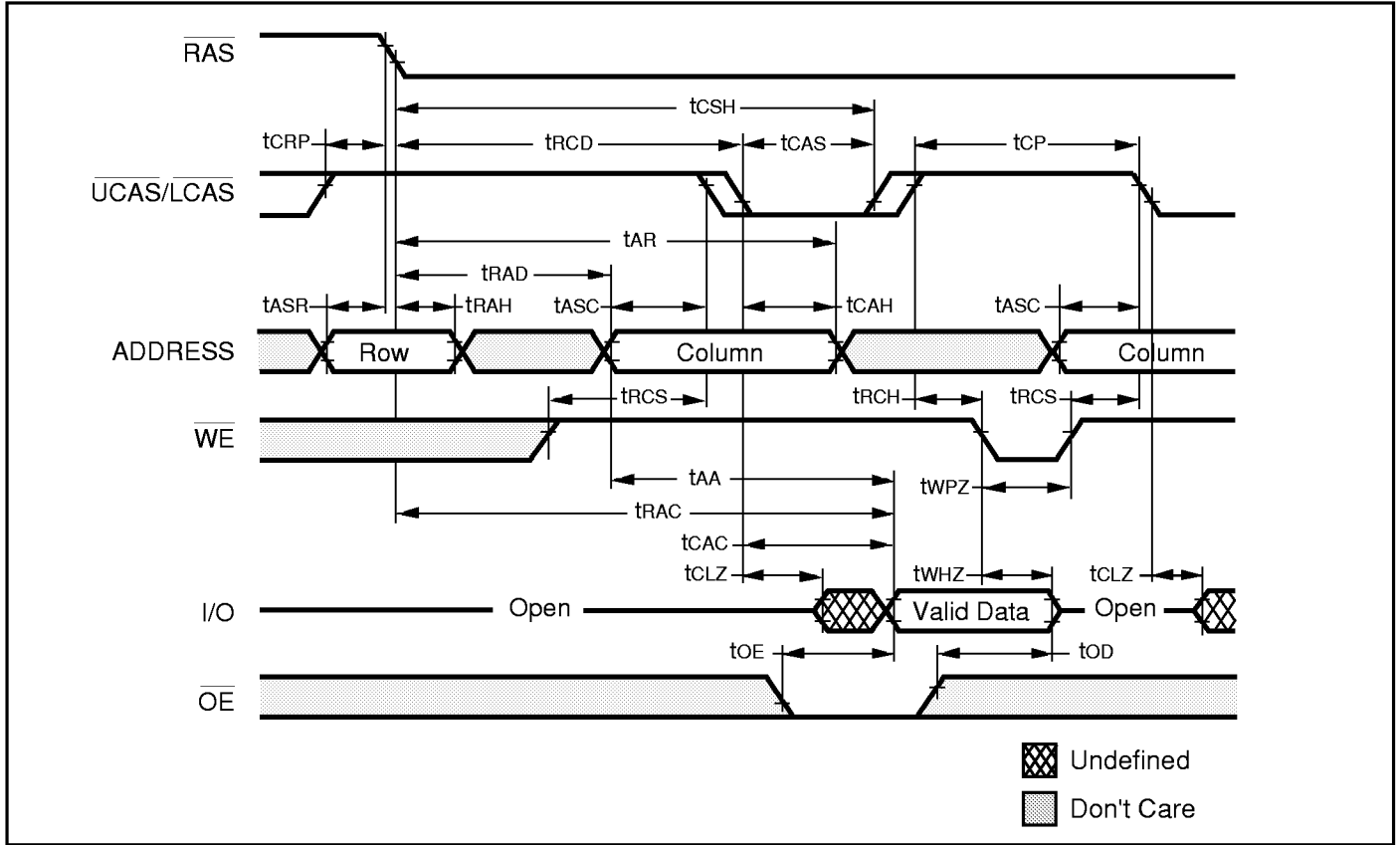

RAS-ONLY REFRESH CYCLE (\overline{OE} , \overline{WE} = DON'T CARE)

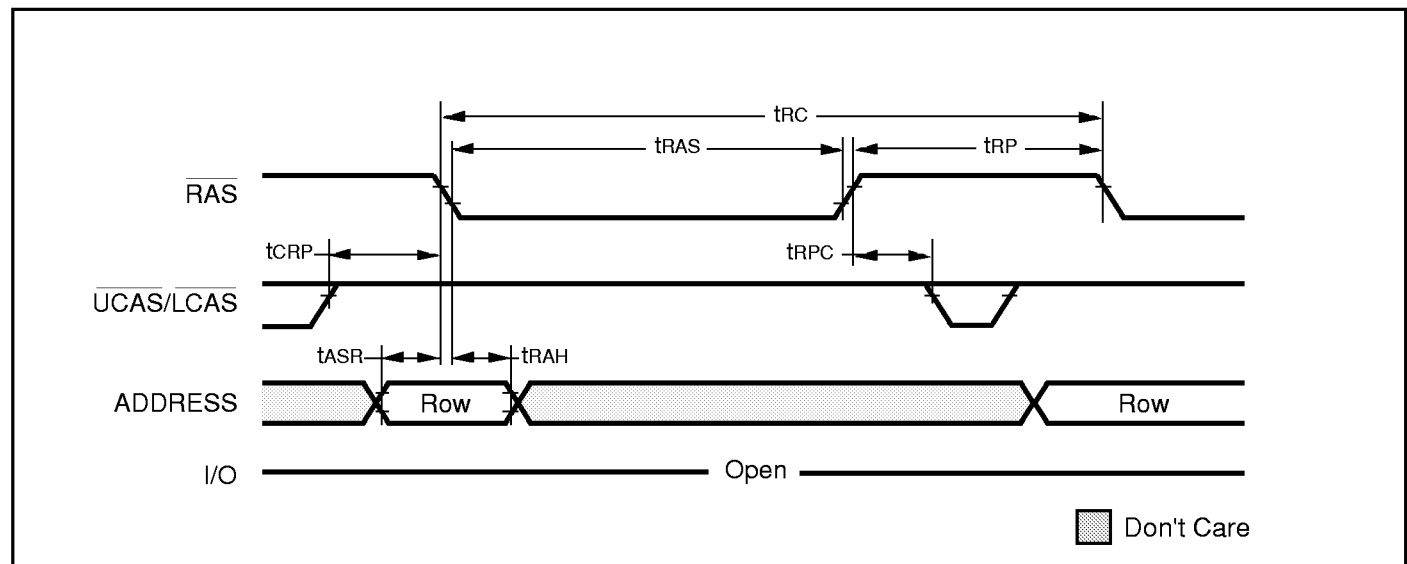

CBR REFRESH CYCLE (Addresses; \overline{WE} , \overline{OE} = DON'T CARE)

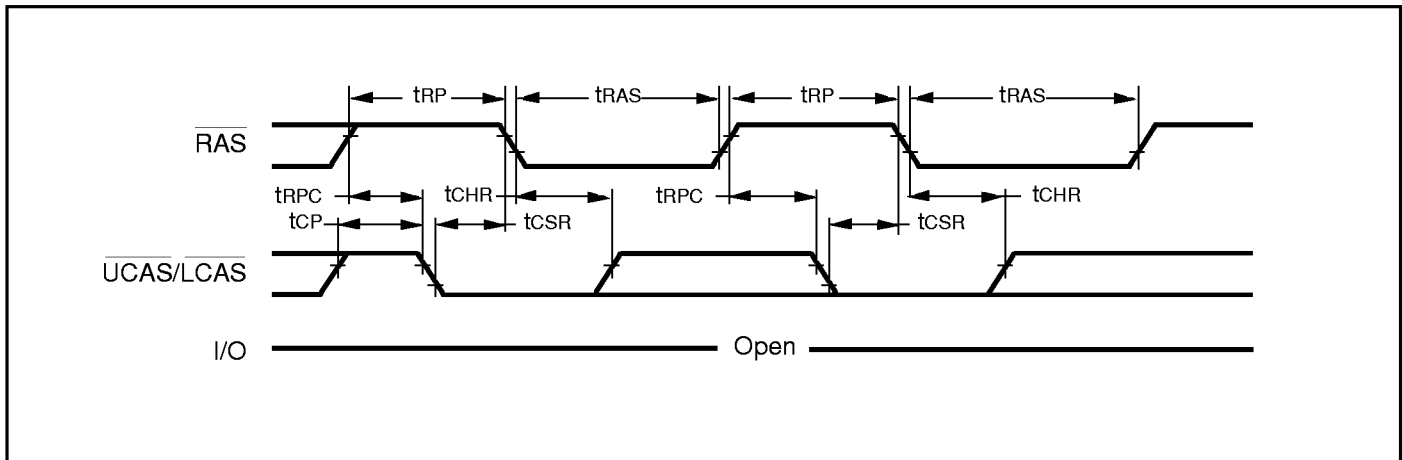

HIDDEN REFRESH CYCLE (\overline{WE} = HIGH; \overline{OE} = LOW)⁽¹⁾

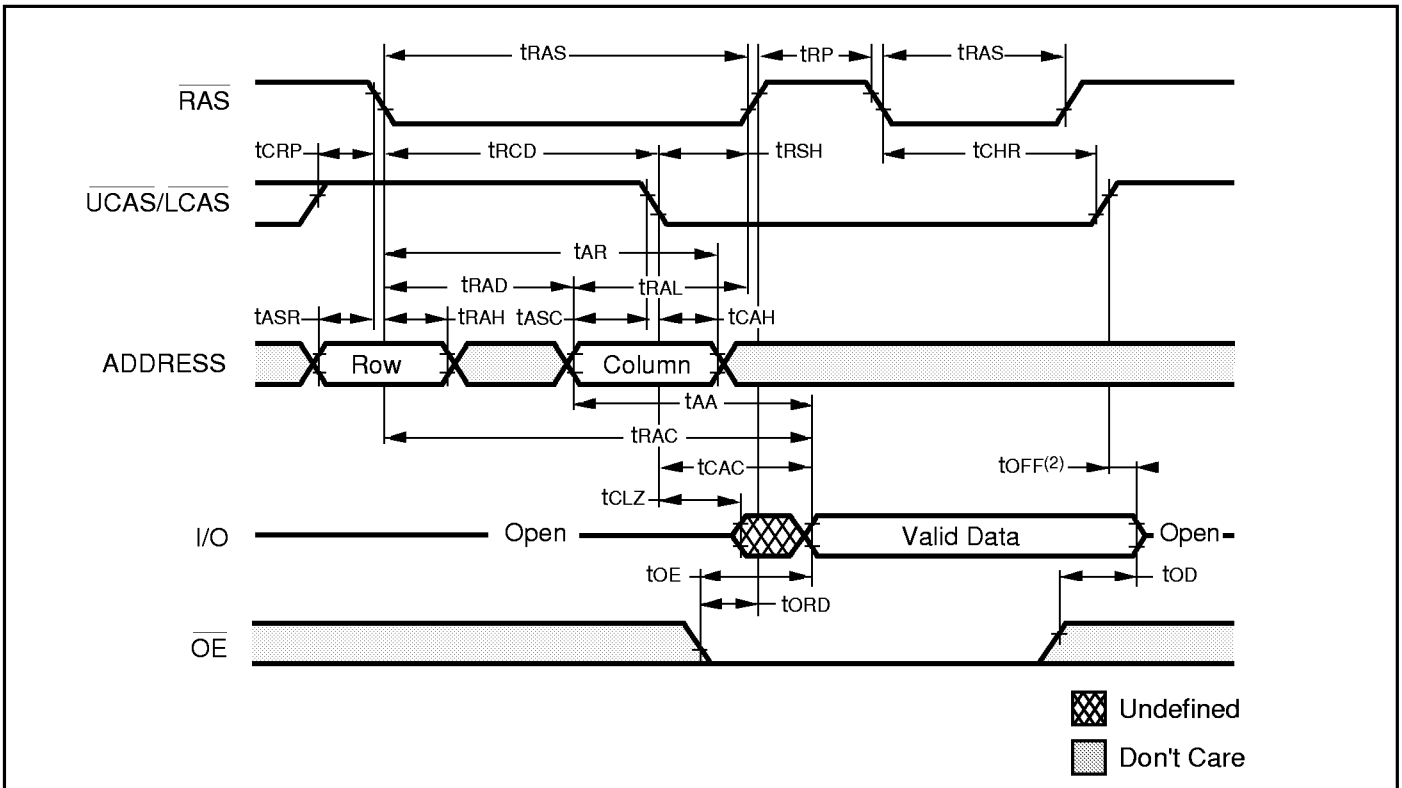

Notes:

1. A Hidden Refresh may also be performed after a Write Cycle. In this case, \overline{WE} = LOW and \overline{OE} = HIGH.
2. t_{OFF} is referenced from rising edge of RAS or CAS, whichever occurs last.

400-MIL PLASTIC SOJ

Package Code: K

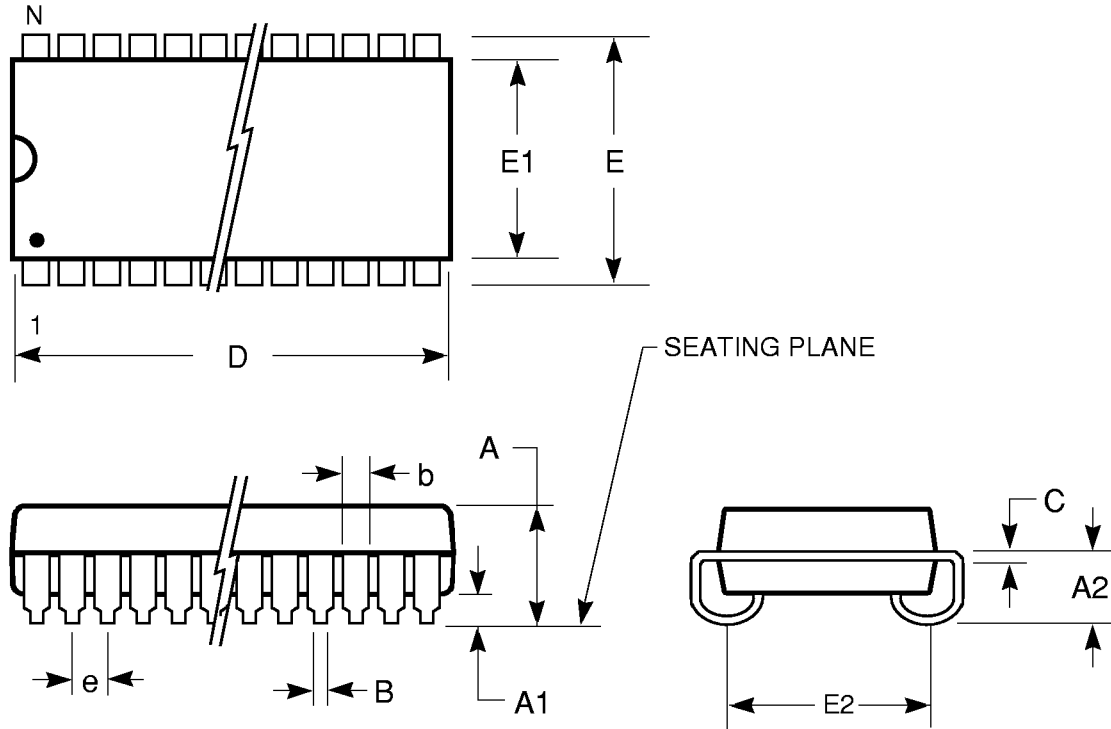

400-mil Plastic SOJ (K)					
	Inches		Millimeters		
Symbol	Min	Max	Min	Max	
Ref. Std.					
N	40				
A	—	0.144	—	3.66	
A1	0.025	—	0.66	—	
A2	0.082	—	2.08	—	
B	0.015	0.019	0.38	0.48	
b	0.026	0.032	0.66	0.81	
C	0.007	0.013	0.18	0.33	
D	1.020	1.030	25.91	26.16	
E	0.430	0.450	10.92	11.43	
E1	0.395	0.405	10.03	10.28	
E2	0.346	0.386	8.79	9.80	
e	0.050 BSC		1.27 BSC		

Notes:

1. Controlling dimension: inches, unless otherwise specified.
2. BSC = Basic lead spacing between centers.
3. Dimensions D and E1 do not include mold flash protrusions and should be measured from the bottom of the package.
4. Formed leads shall be planar with respect to one another within 0.004 inches at the seating plane.

PLASTIC TSOP

Package Code: T (Type 2)

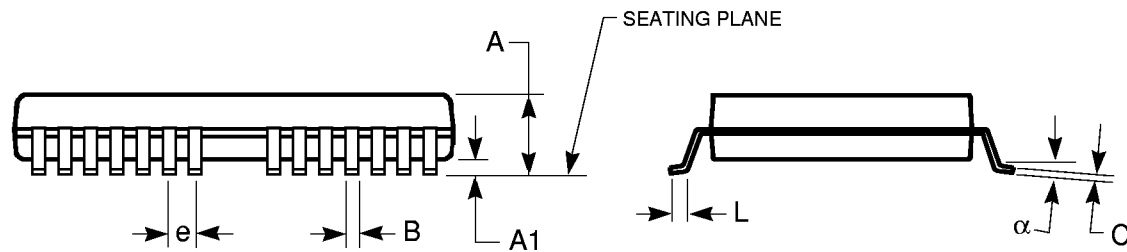
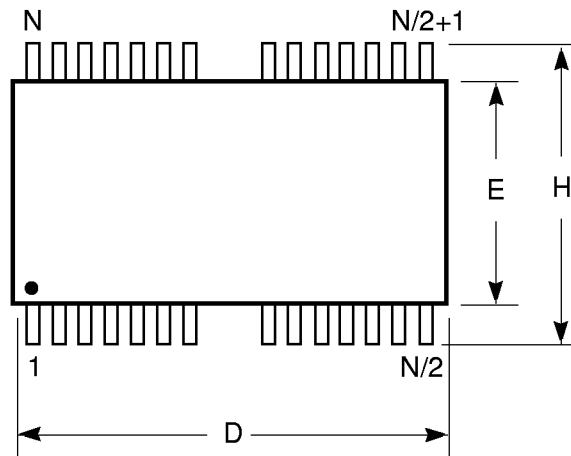

Plastic TSOP (T - Type II)				
	Inches		Millimeters	
Symbol	Min	Max	Min	Max
Ref. Std.				
N	40/44			
A	0.039	0.047	1.00	1.20
A1	0.002	0.008	0.05	0.20
B	0.012	0.016	0.30	0.40
C	0.0047	0.0083	0.12	0.21
D	0.721	0.729	18.313	18.517
E	0.462	0.470	11.735	11.938
e	0.0315 BSC		0.800 BSC	
H	0.396	0.404	10.058	10.262
L	0.017	0.023	0.432	0.584
α	0°	5°	0°	5°

Notes:

1. Controlling dimension: inches, unless otherwise specified.
2. BSC = Basic lead spacing between centers.
3. Dimensions D and E do not include mold flash protrusions and should be measured from the bottom of the package.
4. Formed leads shall be planar with respect to one another within 0.004 inches at the seating plane.

ORDERING INFORMATION**Commercial Range: 0°C to 70°C**

Speed (ns)	Order Part No.	Package
35	IS41C16128-35K	400-mil SOJ
35	IS41C16128-35T	400-mil TSOP (Type 2)
40	IS41C16128-40K	400-mil SOJ
40	IS41C16128-40T	400-mil TSOP (Type 2)
45	IS41C16128-45K	400-mil SOJ
45	IS41C16128-45T	400-mil TSOP (Type 2)
50	IS41C16128-50K	400-mil SOJ
50	IS41C16128-50T	400-mil TSOP (Type 2)
60	IS41C16128-60K	400-mil SOJ
60	IS41C16128-60T	400-mil TSOP (Type 2)

Industrial Range: -40°C to 85°C

Speed (ns)	Order Part No.	Package
35	IS41C16128-35KI	400-mil SOJ
35	IS41C16128-35TI	400-mil TSOP (Type 2)
40	IS41C16128-40KI	400-mil SOJ
40	IS41C16128-40TI	400-mil TSOP (Type 2)
45	IS41C16128-45KI	400-mil SOJ
45	IS41C16128-45TI	400-mil TSOP (Type 2)
50	IS41C16128-50KI	400-mil SOJ
50	IS41C16128-50TI	400-mil TSOP (Type 2)
60	IS41C16128-60KI	400-mil SOJ
60	IS41C16128-60TI	400-mil TSOP (Type 2)

Integrated Silicon Solution, Inc.

2231 Lawson Lane
 Santa Clara, CA 95054
 Fax: (408) 588-0806
 Toll Free: 1-800-379-4774
 email: sales@issi.com
<http://www.issi.com>