

SOJ, TSOP, FP-BGA, TQFP
 Commercial Temp
 Industrial Temp

128K x 16

2Mb Asynchronous SRAM

8, 10, 12, 15ns
3.3V V_{DD}
Center V_{DD} & V_{SS}

Features

- Fast access time: 8, 10, 12, 15ns
- CMOS low power operation: 150/125/110/90 mA at min. cycle time.
- Single 3.3V ± 0.3V power supply
- All inputs and outputs are TTL compatible
- Byte control
- Fully static operation
- Industrial Temperature Option: -40° to 85°C
- Package line up
 - J: 400mil, 44 pin SOJ package
 - TP: 400mil, 44 pin TSOP Type II package
 - T: 10mm x 10mm, 44 pin TQFP
 - U: 6 mm x 8 mm Fine Pitch Ball Grid Array package

Description

The GS72116 is a high speed CMOS static RAM organized as 131,072-words by 16-bits. Static design eliminates the need for external clocks or timing strobes. Operating on a single 3.3V power supply and all inputs and outputs are TTL compatible. The GS72116 is available in a 6x8 mm Fine Pitch BGA package, a 10x10 mm TQFP package, as well as in 400 mil SOJ and 400 mil TSOP Type-II packages.

SOJ 128K x 16 Pin Configuration

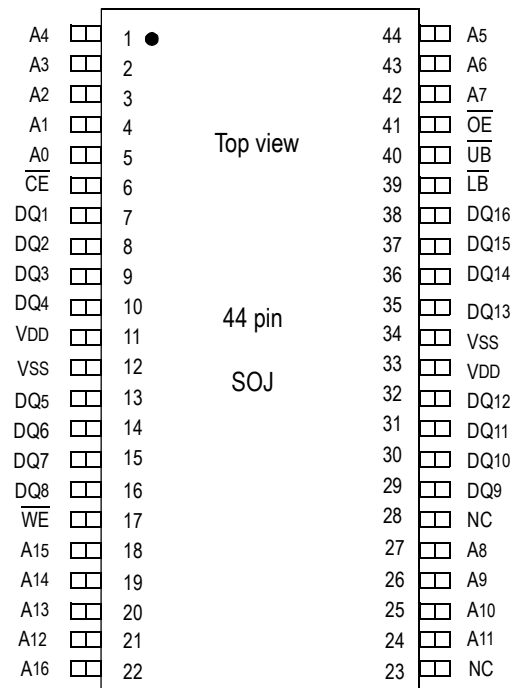

Pin Descriptions

Symbol	Description
A ₀ to A ₁₆	Address input
DQ ₁ to DQ ₁₆	Data input/output
\overline{CE}	Chip enable input
\overline{LB}	Lower byte enable input (DQ ₁ to DQ ₈)
\overline{UB}	Upper byte enable input (DQ ₉ to DQ ₁₆)
\overline{WE}	Write enable input
\overline{OE}	Output enable input
V _{DD}	+3.3V power supply
V _{SS}	Ground
NC	No connect

44 Pin TQFP 128K x 16 Pin Configuration

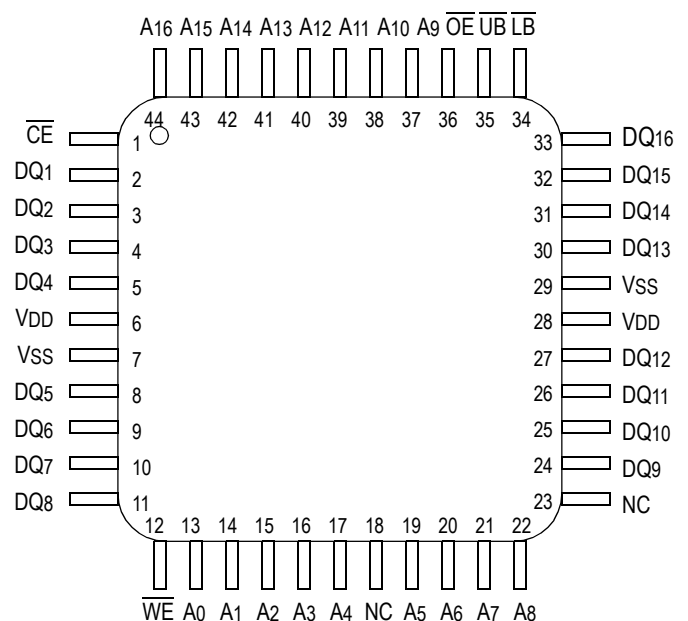

Fine Pitch BGA 128K x 16 Bump Configuration

	1	2	3	4	5	6
A	$\overline{\text{LB}}$	$\overline{\text{OE}}$	A0	A1	A2	NC
B	DQ16	$\overline{\text{UB}}$	A3	A4	$\overline{\text{CE}}$	DQ1
C	DQ14	DQ15	A5	A6	DQ2	DQ3
D	VSS	DQ13	NC	A7	DQ4	VDD
E	VDD	DQ12	NC	A16	DQ5	VSS
F	DQ11	DQ10	A8	A9	DQ7	DQ6
G	DQ9	NC	A10	A11	$\overline{\text{WE}}$	DQ8
H	NC	A12	A13	A14	A15	NC

6mm x 8mm, 0.75mm Bump Pitch
Top View

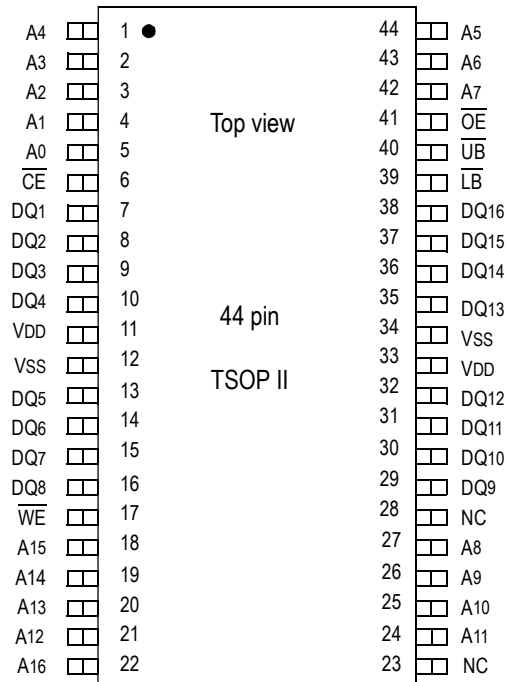
TSOP-II 128K x 16 Pin Configuration

Block Diagram

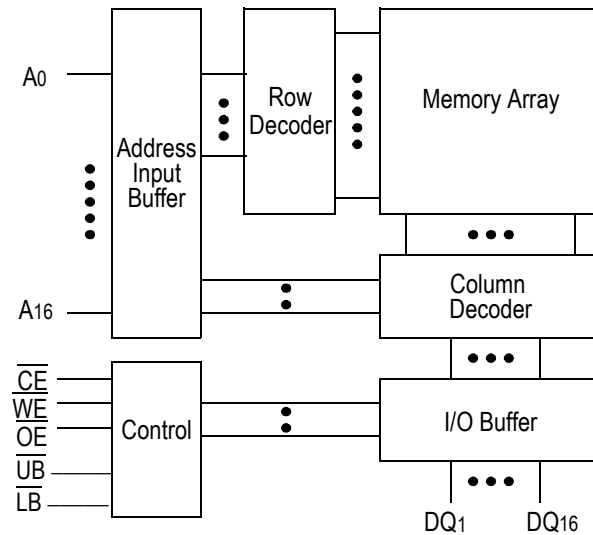

Truth Table

\overline{CE}	\overline{OE}	\overline{WE}	\overline{LB}	\overline{UB}	DQ1 to DQ8	DQ9 to DQ16	VDD Current
H	X	X	X	X	Not Selected	Not Selected	ISB1, ISB2
L	L	H	L	L	Read	Read	IDD
			L	H	Read	High Z	
			H	L	High Z	Read	
L	X	L	L	L	Write	Write	
			L	H	Write	Not Write, High Z	
			H	L	Not Write, High Z	Write	
L	H	H	X	X	High Z	High Z	
L	X	X	H	H	High Z	High Z	

Note: X: "H" or "L"

Absolute Maximum Ratings

Parameter	Symbol	Rating	Unit
Supply Voltage	V _{DD}	-0.5 to +4.6	V
Input Voltage	V _{IN}	-0.5 to V _{DD} +0.5 (≤ 4.6V max.)	V
Output Voltage	V _{OUT}	-0.5 to V _{DD} +0.5 (≤ 4.6V max.)	V
Allowable power dissipation	PD	0.7	W
Storage temperature	T _{STG}	-55 to 150	°C

Note:

Permanent device damage may occur if Absolute Maximum Ratings are exceeded. Functional operation shall be restricted to Recommended Operating Conditions. Exposure to higher than recommended voltages for extended periods of time could affect device reliability.

Recommended Operating Conditions

Parameter	Symbol	Min	Typ	Max	Unit
Supply Voltage for -10/12/15	V _{DD}	3.0	3.3	3.6	V
Supply Voltage for -8	V _{DD}	3.135	3.3	3.6	V
Input High Voltage	V _{IH}	2.0	-	V _{DD} +0.3	V
Input Low Voltage	V _{IL}	-0.3	-	0.8	V
Ambient Temperature, Commercial Range	T _{Ac}	0	-	70	°C
Ambient Temperature, Industrial Range	T _{AI}	-40	-	85	°C

Note:

1. Input overshoot voltage should be less than V_{DD}+2V and not exceed 20ns.
2. Input undershoot voltage should be greater than -2V and not exceed 20ns.

Capacitance

Parameter	Symbol	Test Condition	Max	Unit
Input Capacitance	C _{IN}	V _{IN} =0V	5	pF
Output Capacitance	C _{OUT}	V _{OUT} =0V	7	pF

Notes:

1. Tested at T_A=25°C, f=1MHz
2. These parameters are sampled and are not 100% tested

DC I/O Pin Characteristics

Parameter	Symbol	Test Conditions	Min	Max
Input Leakage Current	I_{IL}	$V_{IN} = 0 \text{ to } V_{DD}$	-1 μ A	1 μ A
Output Leakage Current	I_{LO}	Output High Z $V_{OUT} = 0 \text{ to } V_{DD}$	-1 μ A	1 μ A
Output High Voltage	V_{OH}	$I_{OH} = -4\text{mA}$	2.4	
Output Low Voltage	V_{OL}	$I_{LO} = +4\text{mA}$		0.4V

Power Supply Currents

Parameter	Symbol	Test Conditions	0 to 70°C				-40 to 85°C		
			8ns	10ns	12ns	15ns	10ns	12ns	15ns
Operating Supply Current	I_{DD}	$\overline{CE} \leq V_{IL}$ All other inputs $\geq V_{IH}$ or $\leq V_{IL}$ Min. cycle time $I_{OUT} = 0 \text{ mA}$	150mA	125mA	110mA	90mA	135mA	120mA	100mA
Standby Current	I_{SB1}	$\overline{CE} \geq V_{IH}$ All other inputs $\geq V_{IH}$ or $\leq V_{IL}$ Min. cycle time	55mA	50mA	45mA	40mA	60mA	55mA	50mA
Standby Current	I_{SB2}	$\overline{CE} \geq V_{DD} - 0.2V$ All other inputs $\geq V_{DD} - 0.2V$ or $\leq 0.2V$	15mA				25mA		

AC Test Conditions

Parameter	Conditions
Input high level	$V_{IH}=2.4V$
Input low level	$V_{IL}=0.4V$
Input rise time	$t_r=1V/ns$
Input fall time	$t_f=1V/ns$
Input reference level	1.4V
Output reference level	1.4V
Output load	Fig. 1 & 2

Note:

1. Include scope and jig capacitance.
2. Test conditions as specified with output loading as shown in Fig. 1 unless otherwise noted
3. Output load 2 for t_{LZ} , t_{HZ} , t_{OLZ} and t_{OHZ} .

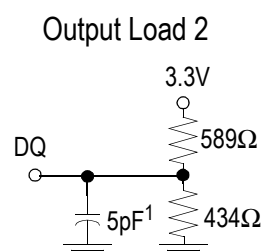
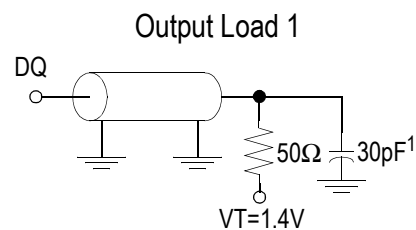

AC Characteristics

Read Cycle

Parameter	Symbol	-8		-10		-12		-15		Unit
		Min	Max	Min	Max	Min	Max	Min	Max	
Read cycle time	t _{RC}	8	---	10	---	12	---	15	---	ns
Address access time	t _{AA}	---	8	---	10	---	12	---	15	ns
Chip enable access time (\overline{CE})	t _{AC}	---	8	---	10	---	12	---	15	ns
Byte enable access time (\overline{UB} , \overline{LB})	t _{AB}	---	3.5	---	4	---	5	---	6	ns
Output enable to output valid (\overline{OE})	t _{OE}	---	3.5	---	4	---	5	---	6	ns
Output hold from address change	t _{OH}	3	---	3	---	3	---	3	---	ns
Chip enable to output in low Z (\overline{CE})	t _{LZ} *	3	---	3	---	3	---	3	---	ns
Output enable to output in low Z (\overline{OE})	t _{OLZ} *	0	---	0	---	0	---	0	---	ns
Byte enable to output in low Z (\overline{UB} , \overline{LB})	t _{BLZ} *	0	---	0	---	0	---	0	---	ns
Chip disable to output in High Z (\overline{CE})	t _{HZ} *	---	4	---	5	---	6	---	7	ns
Output disable to output in High Z (\overline{OE})	t _{OHZ} *	---	3.5	---	4	---	5	---	6	ns
Byte disable to output in High Z (\overline{UB} , \overline{LB})	t _{BHZ} *	---	3.5	---	4	---	5	---	6	ns

* These parameters are sampled and are not 100% tested

Read Cycle 1: $\overline{CE} = \overline{OE} = V_{IL}$, $\overline{WE} = V_{IH}$, \overline{UB} and, or $\overline{LB} = V_{IL}$

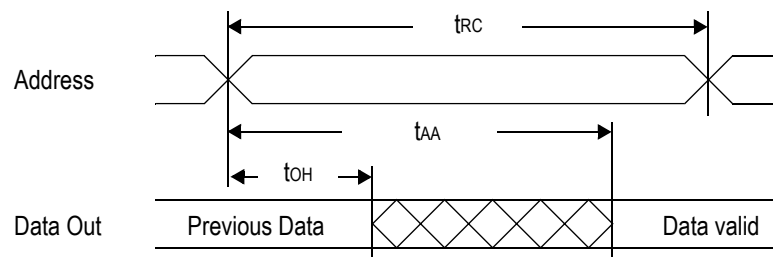

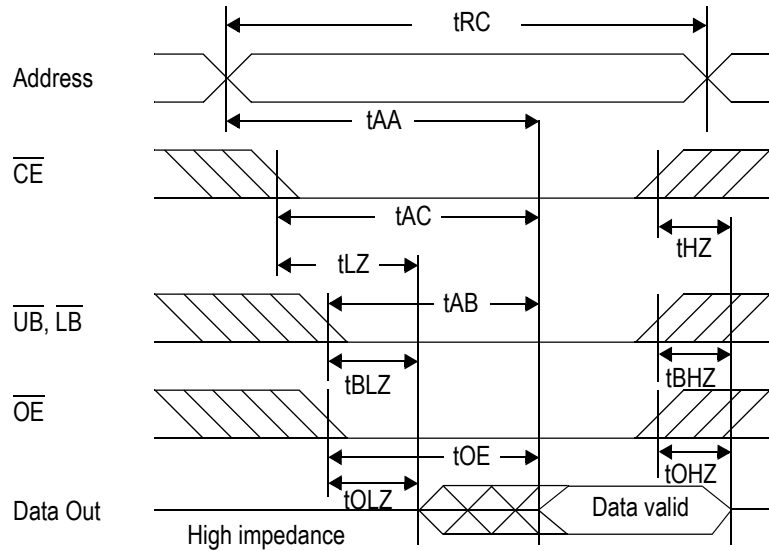
Read Cycle 2: $\overline{WE} = V_{IH}$

Write Cycle

Parameter	Symbol	-8		-10		-12		-15		Unit
		Min	Max	Min	Max	Min	Max	Min	Max	
Write cycle time	t_{WC}	8	---	10	---	12	---	15	---	ns
Address valid to end of write	t_{AW}	5.5	---	7	---	8	---	10	---	ns
Chip enable to end of write	t_{CW}	5.5	---	7	---	8	---	10	---	ns
Byte enable to end of write	t_{BW}	5.5	---	7	---	8	---	10	---	ns
Data set up time	t_{DW}	4	---	5	---	6	---	7	---	ns
Data hold time	t_{DH}	0	---	0	---	0	---	0	---	ns
Write pulse width	t_{WP}	5.5	---	7	---	8	---	10	---	ns
Address set up time	t_{AS}	0	---	0	---	0	---	0	---	ns
Write recovery time (\overline{WE})	t_{WR}	0	---	0	---	0	---	0	---	ns
Write recovery time (\overline{CE})	t_{WR1}	0	---	0	---	0	---	0	---	ns
Output Low Z from end of write	t_{WLZ}^*	3	---	3	---	3	---	3	---	ns
Write to output in High Z	t_{WHZ}^*	---	3.5	---	4	---	5	---	6	ns

* These parameters are sampled and are not 100% tested

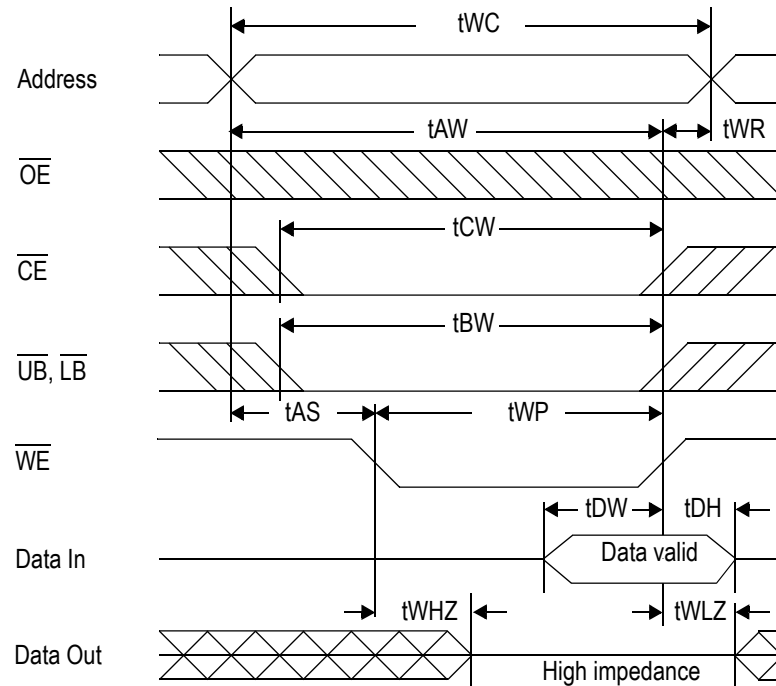
Write Cycle 1: \overline{WE} control



Write Cycle 2: \overline{CE} control

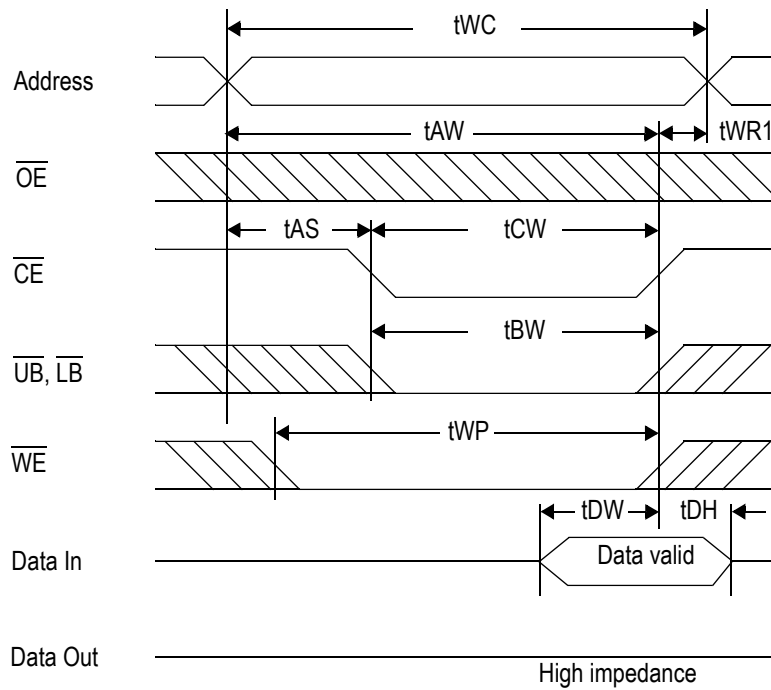

Write Cycle 3: \overline{UB} , \overline{LB} control

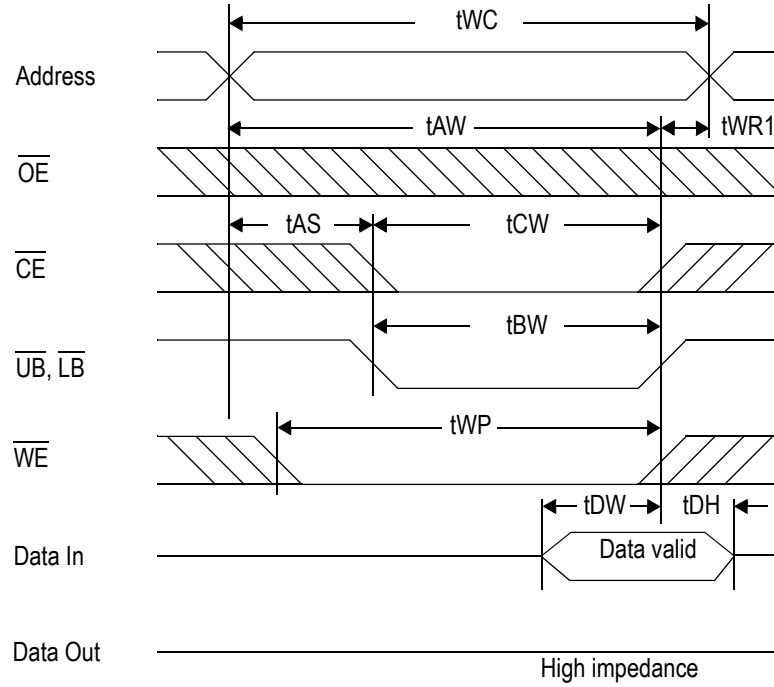

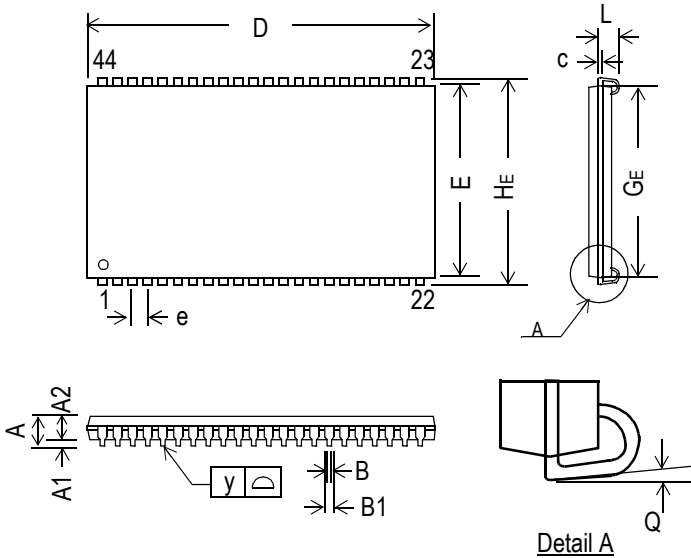
44 Pin, 400 mil SOJ

Symbol	Dimension in inch			Dimension in mm		
	min	nom	max	min	nom	max
A	-	-	0.148	-	-	3.759
A1	0.025	-	-	0.635	-	-
A2	0.105	0.110	0.115	2.667	2.794	2.921
B	-	0.018	-	-	0.457	-
B1	0.026	0.028	0.032	0.660	0.711	0.813
c	-	0.008	-	-	0.203	-
D	1.120	1.125	1.130	28.44	28.58	28.70
E	0.395	0.400	0.405	10.033	10.160	10.287
e	-	0.05	-	-	1.27	-
HE	0.435	0.440	0.445	11.049	11.176	11.303
GE	0.360	0.370	0.380	9.144	9.398	9.652
L	0.082	0.087	0.106	2.083	2.210	2.70
y	-	-	0.004	-	-	0.102
Q	0°	-	7°	0°	-	7°

Note:

1. Dimension D & E do not include interlead flash
2. Dimension B1 does not include dambar protrusion / intrusion

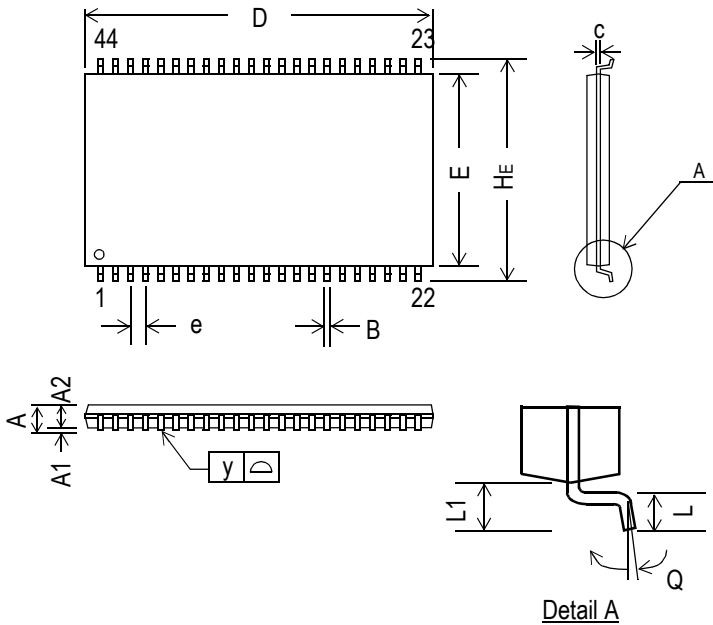
44 Pin, 400 mil TSOP-II

Symbol	Dimension in inch			Dimension in mm		
	min	nom	max	min	nom	max
A	-	-	0.047	-	-	1.20
A1	0.002	-	-	0.05	-	-
A2	0.037	0.039	0.041	0.95	1.00	1.05
B	0.01	0.014	0.018	0.25	0.35	0.45
c	-	0.006	-	-	0.15	-
D	0.721	0.725	0.729	18.31	18.41	18.51
E	0.396	0.400	0.404	10.06	10.16	10.26
e	-	0.031	-	-	0.80	-
HE	0.455	0.463	0.471	11.56	11.76	11.96
L	0.016	0.020	0.024	0.40	0.50	0.60
L1	-	0.031	-	-	0.80	-
y	-	-	0.004	-	-	0.10
Q	0°	-	5°	0°	-	5°

Note:

1. Dimension D & E do not include interlead flash
2. Dimension B does not include dambar protrusion / intrusion
3. Controlling dimension: mm

44 Pin TQFP (LQFP) Package

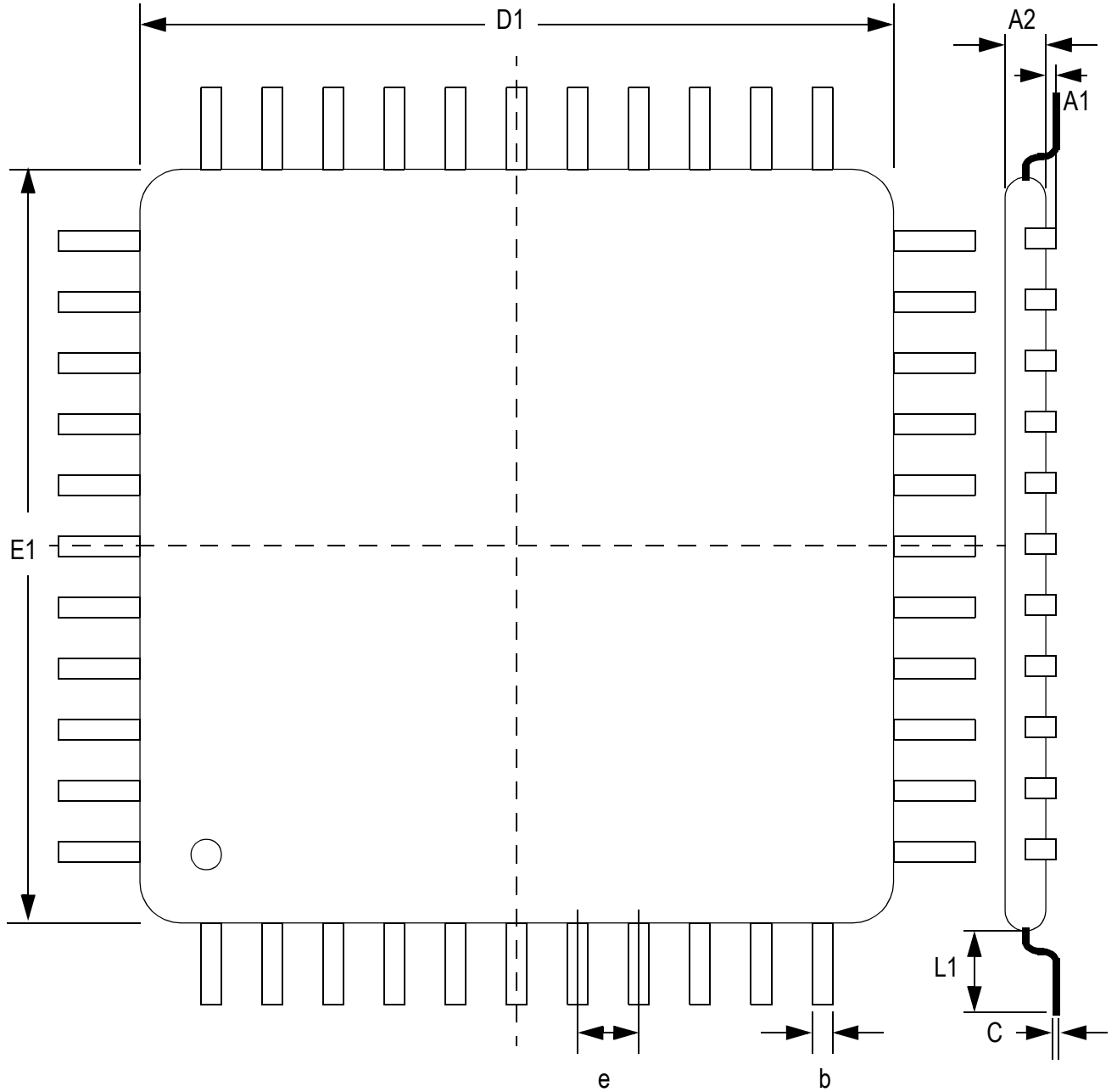

Body Size		Lead Count	Standoff	Body Thickness	Lead Length	Lead Width	Lead Thickness	Lead Pitch
E1	D1		A1	A2	L1	b	c	e
10	10	44	0.1	1.4	1.0	0.3	0.127	0.8

Units: mm

6mm x 8mm Fine Pitch BGA

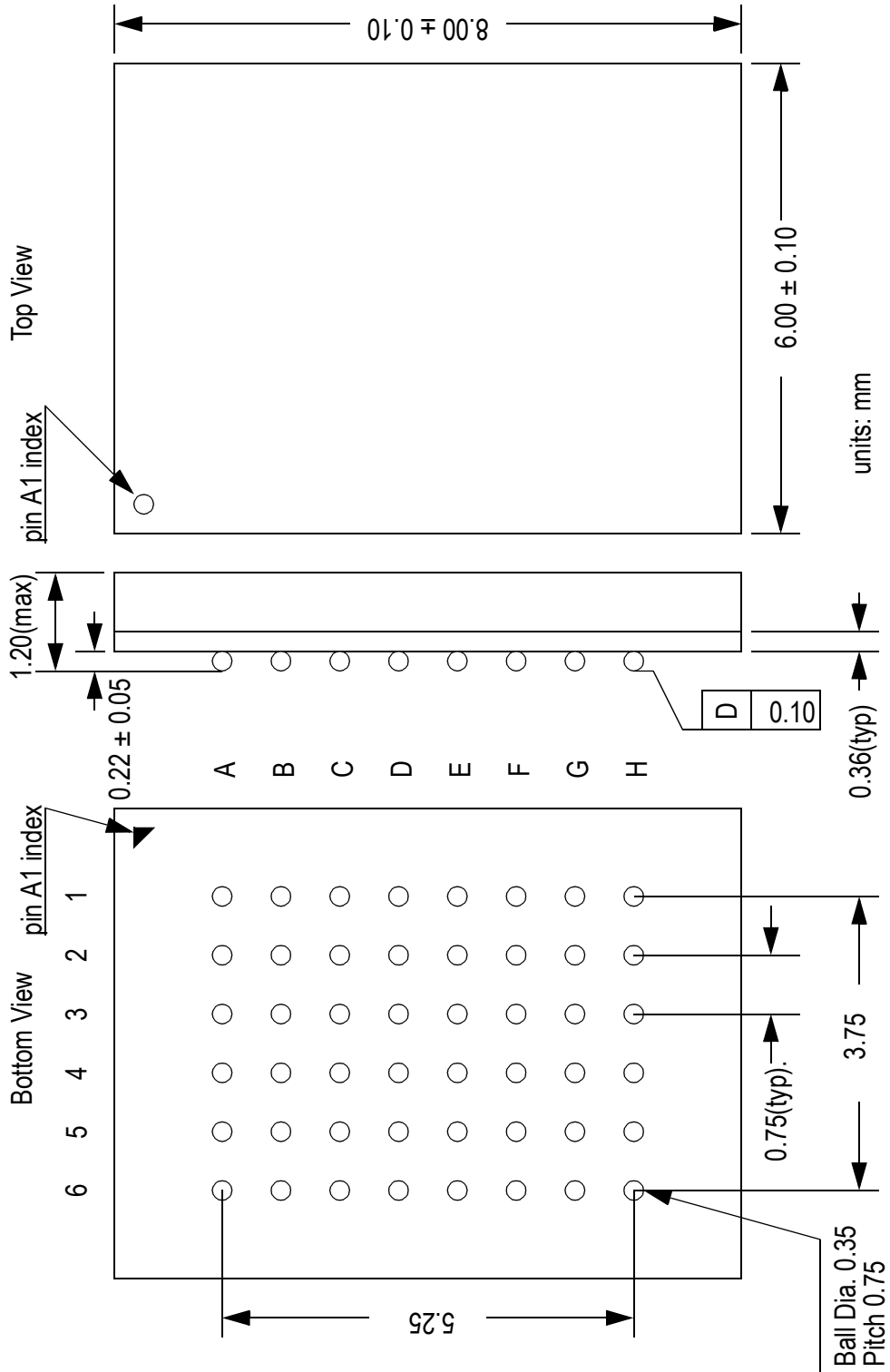

Ordering Information

Part Number *	Package	Access Time	Temp. Range	Status
GS72116TP-8	400 mil TSOP-II	8 ns	Commercial	
GS72116TP-10	400 mil TSOP-II	10 ns	Commercial	
GS72116TP-12	400 mil TSOP-II	12 ns	Commercial	
GS72116TP-15	400 mil TSOP-II	15 ns	Commercial	
GS72116TP-8I	400 mil TSOP-II	8 ns	Industrial	
GS72116TP-10I	400 mil TSOP-II	10 ns	Industrial	
GS72116TP-12I	400 mil TSOP-II	12 ns	Industrial	
GS72116TP-15I	400 mil TSOP-II	15 ns	Industrial	
GS72116J-8	400 mil SOJ	8 ns	Commercial	
GS72116J-10	400 mil SOJ	10 ns	Commercial	
GS72116J-12	400 mil SOJ	12 ns	Commercial	
GS72116J-15	400 mil SOJ	15 ns	Commercial	
GS72116J-8I	400 mil SOJ	8 ns	Industrial	
GS72116J-10I	400 mil SOJ	10 ns	Industrial	
GS72116J-12I	400 mil SOJ	12 ns	Industrial	
GS72116J-15I	400 mil SOJ	15 ns	Industrial	
GS72116T-8	44 pin TQFP	8 ns	Commercial	
GS72116T-10	44 pin TQFP	10 ns	Commercial	
GS72116T-12	44 pin TQFP	12 ns	Commercial	
GS72116T-15	44 pin TQFP	15 ns	Commercial	
GS72116T-8I	44 pin TQFP	8 ns	Industrial	
GS72116T-10I	44 pin TQFP	10 ns	Industrial	
GS72116T-12I	44 pin TQFP	12 ns	Industrial	
GS72116T-15I	44 pin TQFP	15 ns	Industrial	

Ordering Information

Part Number *	Package	Access Time	Temp. Range	Status
GS72116U-8	Fine Pitch BGA	8 ns	Commercial	
GS72116U-10	Fine Pitch BGA	10 ns	Commercial	
GS72116U-12	Fine Pitch BGA	12 ns	Commercial	
GS72116U-15	Fine Pitch BGA	15 ns	Commercial	
GS72116U-8I	Fine Pitch BGA	8 ns	Industrial	
GS72116U-10I	Fine Pitch BGA	10 ns	Industrial	
GS72116U-12I	Fine Pitch BGA	12 ns	Industrial	
GS72116U-15I	Fine Pitch BGA	15 ns	Industrial	

* Customers requiring delivery in Tape and Reel should add the character "T" to the end of the part number. For example: GS72116TP-8T

Revision History

Rev. Code: Old; New	Types of Changes Format or Content	Page #/Revisions/Reason
GS721Rev1.05 10/19991/ 2000K;Rev 5 2/2000L	Format/Content	1. GSI Logo 2.