

# PRELIMINARY DATASHEET



## **WMS7100 / 7101**

**NON-VOLATILE DIGITAL POTENTIOMETERS**

**WITH UP/DOWN (3-WIRE) INTERFACE,**

**10KOHM, 50KOHM, 100KOHM RESISTANCE**

**256 TAPS**

**WITHOUT / WITH OUTPUT BUFFER**



## 1. GENERAL DESCRIPTION

The WMS7100/7101 is a single channel 256-tap non-volatile linear digital potentiometer available in 10K $\Omega$ , 50K $\Omega$  and 100K $\Omega$  resistance. The device consists of Up/Down serial interface, tap register, decoder, resistor array, wiper switches, NV memory and control logics.

The WMS7100 device can be configured as a two-terminal variable resistor or a three-terminal voltage divider without an output buffer, but the WMS7101 device, which has a built-in output buffer, can only be configured as a three-terminal voltage divider. Both devices can be used in a wide variety of applications.

The output of the potentiometer is determined by its wiper position, which varies linearly between its end terminals,  $R_A/V_A$  and  $R_B/V_B$ . The wiper position,  $R_w/V_w$ , is controlled by Up/Down serial interface ( $\overline{CS}$ ,  $\overline{INC}$  and U/D) through the Tap Register (TR). In addition, the wiper position can also be stored into a non-volatile memory location (NVMEM0), which is then automatically recalled upon power up.

## 2. FEATURES

- Drop-in replacement for many popular parts
- Single linear-taper channel
- 256 taps
- 10K, 50K and 100K end-to-end resistance
- $V_{SS}$  to  $V_{DD}$  terminal voltages
- Automatic recall of wiper position when power-on
- Potentiometer control through Up/Down (3-wire) serial interface
- Endurance 100,000 cycles
- Data retention 100 years
- Package options:
  - 8-pin PDIP, SOIC or MSOP
- Industrial temperature range: -40° to 85°C
- Single supply operation : 2.7V to 5.5V

# WMS7100 / 7101



## 3. BLOCK DIAGRAM

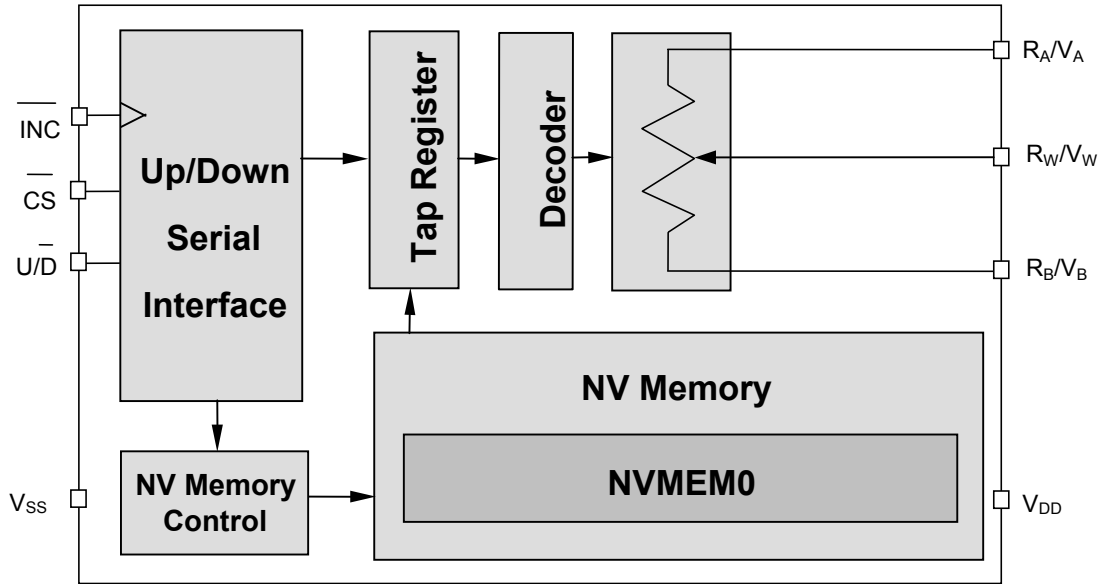

FIGURE 1 – WMS7100 BLOCK DIAGRAM (Rheostat/Divider Mode)

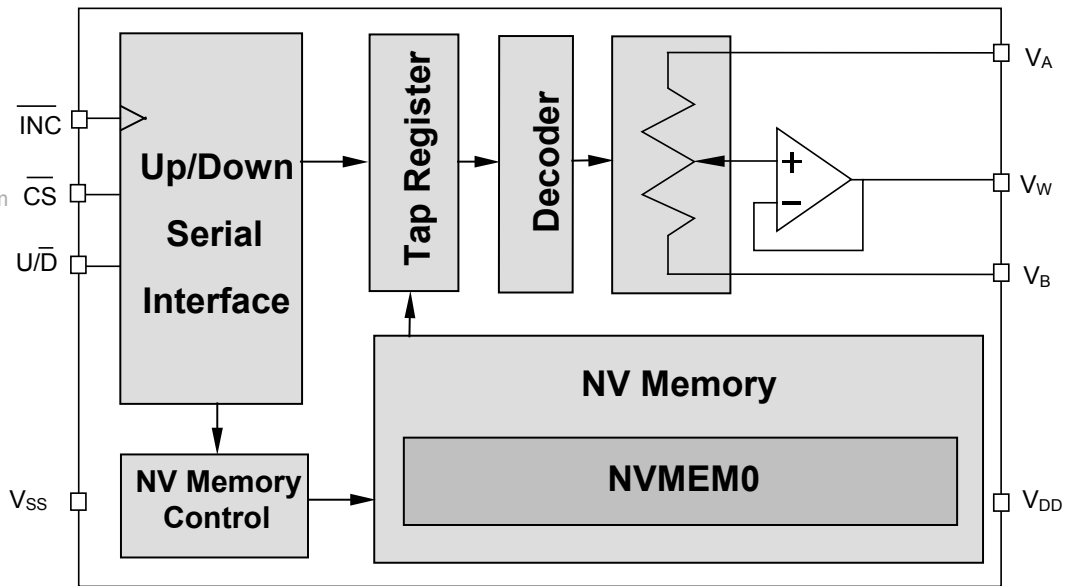

FIGURE 2 – WMS7101 BLOCK DIAGRAM (Divider Mode)

www.DataSheet4U.com



#### **4. TABLE OF CONTENTS**

1. GENERAL DESCRIPTION.....	2
2. FEATURES .....	2
3. BLOCK DIAGRAM.....	3
4. TABLE OF CONTENTS .....	4
5. PIN CONFIGURATION .....	5
6. PIN DESCRIPTION .....	6
7. FUNCTIONAL DESCRIPTION.....	7
7.1. Rheostat And Divider Operations .....	7
7.1.1. Rheostat Configuration .....	7
7.1.2. Divider Configuration.....	7
7.2. Non-Volatile Memory (NVMEM0) .....	7
7.3. Serial Data Interface .....	8
7.4. Operation Overview .....	8
8. TIMING DIAGRAMS.....	9
9. ABSOLUTE MAXIMUM RATINGS & OPERATING CONDITIONS .....	11
10. ELECTRICAL CHARACTERISTICS .....	12
10.1 Test Circuits .....	14
11. TYPICAL APPLICATION CIRCUITS.....	15
11.1. Layout Considerations.....	17
12. PACKAGE DRAWINGS AND DIMENSIONS.....	18
13. ORDERING INFORMATION .....	21
14. VERSION HISTORY .....	22

# WMS7100 / 7101



## 5. PIN CONFIGURATION

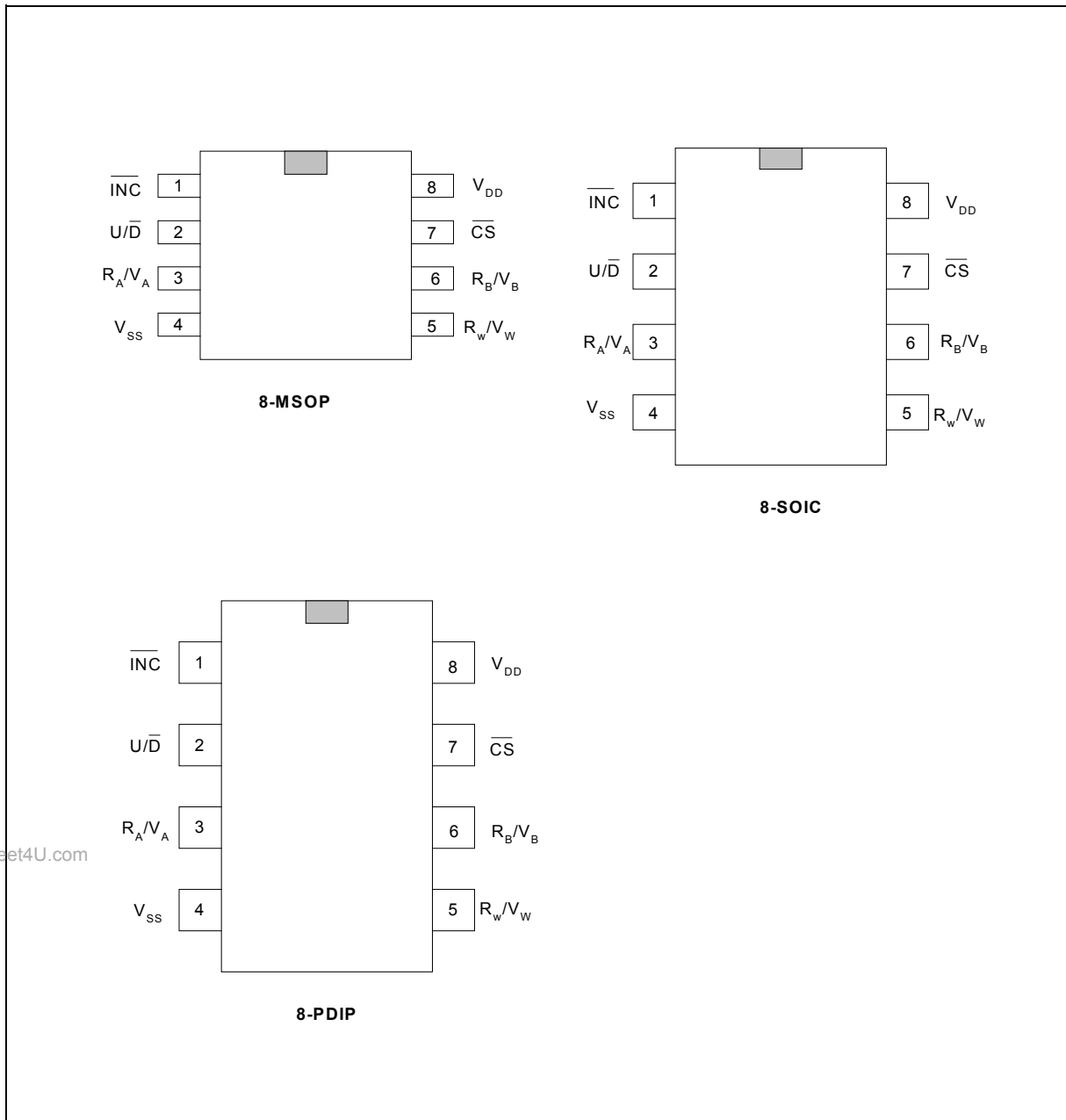

www.DataSheet4U.com



## 6. PIN DESCRIPTION

TABLE 1 – PIN DESCRIPTION

Pin Name	Description
$\overline{CS}$	<b>Chip Select:</b> When $\overline{CS}$ is LOW, the device is enabled. When $\overline{CS}$ is HIGH, the part is deselected and is in standby mode
$U/\overline{D}$	<b>Up/Down Control:</b> HIGH state enables the wiper to move towards the $R_A / V_A$ terminal, while LOW state implies the wiper moves towards the $R_B / V_B$ terminal
$\overline{INC}$	<b>Increment Control:</b> When $\overline{CS}$ is LOW, a HIGH-LOW transition on $\overline{INC}$ will move the wiper one increment either up or down based on the $U/\overline{D}$ input
$R_A/V_A$	<b>High terminal</b> of the device
$R_B/V_B$	<b>Low terminal</b> of the device
$R_W/V_W$	<b>Wiper Terminal:</b> Output of the resistor array is determined by the $\overline{INC}$ , $U/\overline{D}$ and $\overline{CS}$ inputs
$V_{SS}$	Ground pin, logic ground reference
$V_{DD}$	Power Supply

Notes: The terminology of high and low terminals above references to the relative position of the terminal with respect to the wiper moving direction and not the voltage potential of the terminal.



## 7. FUNCTIONAL DESCRIPTION

### 7.1. RHEOSTAT AND DIVIDER OPERATIONS

The WMS7100 device can operate as either a two-terminal variable resistor or a three-terminal voltage divider without an output buffer. However, the WMS7101 can only operate in a three-terminal voltage divider with an output buffer.

#### 7.1.1. Rheostat Configuration

In the rheostat mode, the WMS7100 can be configured as a two-terminal resistive element, where one terminal is connected to one end of the resistor ( $R_A$  or  $R_B$ ) and the other terminal is the wiper ( $R_W$ ). The moving direction of the wiper depends upon the setting of  $U/\bar{D}$  control signal. When the  $U/\bar{D}$  is set to Up, then the wiper moves towards  $R_A$ . Conversely, when the  $U/\bar{D}$  is set to Down, then the wiper moves towards  $R_B$ . The wiper movement to either direction is controlled by toggling the  $\overline{INC}$  signal from HIGH to LOW.

This configuration controls the resistance between the wiper and either end. The wiper resistance can be adjusted by either changing the wiper position or loading a stored wiper position value from NVMEM0 upon power up.

#### 7.1.2. Divider Configuration

Additionally, the WMS7100 can also be configured as a voltage divider. With an input voltage applied to one end (usually  $V_A$ ), the ground is connected to the other end (usually  $V_B$ ). These input voltages cannot exceed the  $V_{DD}$  level or go below the  $V_{SS}$  level. The voltage on the wiper,  $V_W$ , is proportional to the wiper position with respect to the voltage difference between  $V_A$  and  $V_B$ . The moving direction of the wiper depends upon the setting of the  $U/\bar{D}$  control signal. When the  $U/\bar{D}$  is set to Up, then the wiper moves towards  $V_A$ . Conversely, when the  $U/\bar{D}$  is set to Down, then the wiper moves towards  $V_B$ . The wiper movement to either direction is controlled by toggling the  $\overline{INC}$  signal from HIGH to LOW.

Nevertheless, the WMS7101 can only be configured as a voltage divider and operate similarly as the WMS7100 device. The only difference is WMS7101 has an output buffer, but WMS7100 doesn't have. Besides, the resistance cannot be directly measured in this configuration.

### 7.2. NON-VOLATILE MEMORY (NVMEM0)

The WMS7100/7101 has one NVMEM0 location available for storing the current wiper position via the Up/Down serial interface. This stored value is automatically recalled and loaded into the tap register upon power up.



### 7.3. SERIAL DATA INTERFACE

The WMS7100/7101 device has a 3-wire Up/Down Serial Interface consisting of  $\overline{\text{CS}}$ ,  $\overline{\text{INC}}$  and  $\overline{\text{U/D}}$  control signals. The key features of this interface include:

- Enabling the device
- Determining the moving direction of the wiper
- Increment/Decrement operation on the wiper
- Non-volatile storage of the present wiper position into the NVMEM0 for automatic recall at power up
- Entering into the standby mode

### 7.4. OPERATION OVERVIEW

The wiper position can be changed either up or down by operating the  $\overline{\text{CS}}$ ,  $\overline{\text{U/D}}$  and  $\overline{\text{INC}}$  control signals.

When  $\overline{\text{CS}}$  is LOW, the device is selected and the wiper can be moved by toggling the  $\overline{\text{INC}}$ . As a result, the wiper moves up when  $\overline{\text{U/D}}$  is HIGH and moves down when  $\overline{\text{U/D}}$  is LOW. The status of the  $\overline{\text{U/D}}$  can be changed even though the  $\overline{\text{CS}}$  remains LOW. This allows the system to enable the device and then move the wiper position either up or down until the desired position is reached.

When the wiper is already at the lowest position, further Down operation won't change the wiper position. Similarly, when the wiper is at the highest position, further Up operation won't change the wiper position too.

The current wiper position can be automatically stored into the NVMEM0 each time the  $\overline{\text{CS}}$  goes from LOW to HIGH while the  $\overline{\text{INC}}$  remains HIGH. Adversely, if the  $\overline{\text{INC}}$  is LOW when the  $\overline{\text{CS}}$  goes HIGH, the wiper position cannot be stored. Meanwhile, the NVMEM0 content is automatically loaded into the wiper during power on.

When the  $\overline{\text{CS}}$  is held HIGH, the device enters into Standby mode and the wiper position cannot be changed. Changing the  $\overline{\text{CS}}$  to LOW exits the Standby mode and enables the device again.

The operating modes of Up/Down interface are summarized in the table below:

$\overline{\text{CS}}$	$\overline{\text{U/D}}$	$\overline{\text{INC}}$	Operation
LOW	HIGH	HIGH to LOW	Move Wiper toward $R_A/V_A$
LOW	LOW	HIGH to LOW	Move Wiper toward $R_B/V_B$
LOW to HIGH	x	HIGH	Store Current Wiper Position
LOW to HIGH	x	LOW	No Store, Return to Standby
HIGH	x	x	Standby

Note: x means don't care





## 8. TIMING DIAGRAMS

Conditions:  $V_{DD} = +2.7V$  to  $5.5V$ ,  $V_A = V_{DD}$ ,  $V_B = 0V$ ,  $T = 25^\circ C$

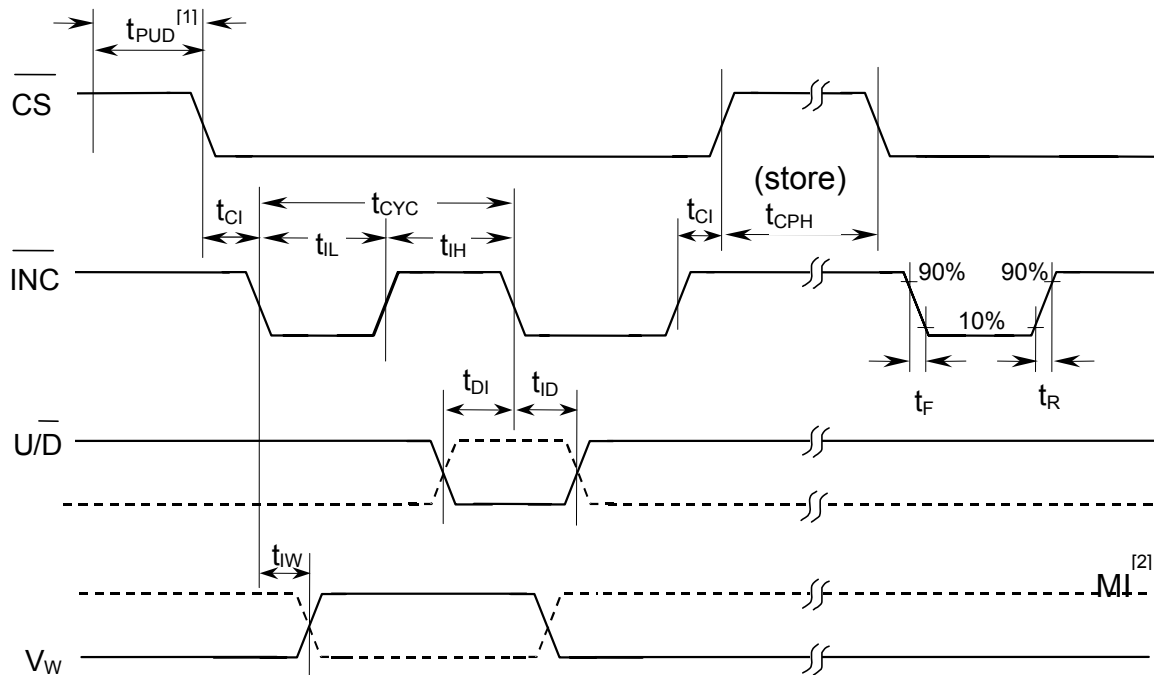

FIGURE 3 –WMS7100/1 TIMING DIAGRAM

www.DataSheet4U.com

Note:

<sup>[1]</sup> This only applies to the Power-Up sequence.

<sup>[2]</sup> MI in the AC Timing diagram (Figure 3) refers to the minimum incremental change in the wiper output due to a change in the wiper position.



TABLE 10 – TIMING PARAMETERS

PARAMETERS	SYMBOL	MIN.	MAX.	UNITS
$\overline{CS}$ to $\overline{INC}$ Setup	$t_{CI}$	100		ns
U/D to $\overline{INC}$ Setup	$t_{DI}$	50		ns
U/D to $\overline{INC}$ Hold	$t_{ID}$	100		ns
$\overline{INC}$ LOW Period	$t_{iL}$	250		ns
$\overline{INC}$ HIGH Period	$t_{iH}$	250		ns
$\overline{INC}$ Inactive to $\overline{CS}$ Inactive	$t_{iC}$	1		$\mu$ s
$\overline{CS}$ Deselect Time (NO STORE)	$t_{CPH}$	100		ns
$\overline{CS}$ Deselect Time (STORE)	$t_{CPH}$	15 (2.7V) 30 (5.5V)		ms
$\overline{INC}$ to Wiper Change	$t_{iW}$		5	$\mu$ s
$\overline{INC}$ Cycle Time	$t_{CYC}$	1		$\mu$ s
$\overline{INC}$ Input Rise and Fall Time	$t_R, t_F$		500	$\mu$ s
Power-Up Delay	$t_{PUD}$		1	ms
$V_{CC}$ Power-Up rate	$t_R V_{CC}$	0.2 (13ms 0-2.7V)	50 (54 $\mu$ s 0-2.7V)	V/ms



## 9. ABSOLUTE MAXIMUM RATINGS & OPERATING CONDITIONS

**TABLE 11 – ABSOLUTE MAXIMUM RATINGS (PACKAGED PARTS) <sup>[1]</sup>**

Conditions	Values
Junction temperature	150°C
Storage temperature	-65° to +150°C
Voltage applied to any pad	(V <sub>SS</sub> – 0.3V) to (V <sub>DD</sub> + 0.3V)
Lead temperature (soldering – 10 seconds)	300°C
V <sub>SS</sub> – V <sub>DD</sub>	-0.3 to 7.0V

**TABLE 12 – OPERATING CONDITIONS (PACKAGED PARTS)**

Conditions	Values
Industrial operating temperature	-40°C to +85°C
Supply voltage (V <sub>DD</sub> )	+2.7V to +5.5V
Ground voltage (V <sub>SS</sub> )	0V

<sup>[1]</sup> Stresses above those listed may cause permanent damage to the device. Exposure to the absolute maximum ratings may affect device performance and reliability. Functional operation is not implied at these conditions.

## WMS7100 / 7101



## 10. ELECTRICAL CHARACTERISTICS

TABLE 12 – ELECTRICAL CHARACTERISTICS (Packaged parts)

PARAMETERS	SYMBOL	MIN.	TYP.	MAX.	UNITS	CONDITIONS <sup>[5]</sup>
<b>Rheostat Mode</b>						
Nominal Resistance	R	-20		+20	%	T=25°C, Wiper open
Different Non Linearity <sup>[2]</sup>	R-DNL	-1	±0.4	+1	LSB	<sup>[6]</sup>
Integral Non Linearity <sup>[2]</sup>	R-INL	-1	±0.6	+1	LSB	<sup>[6]</sup>
Tempo <sup>[1]</sup>	$\Delta R_{AB}/\Delta T$		300		ppm/°C	
Wiper Resistance <sup>[2]</sup>	$R_W$		50		$\Omega$	$V_{DD}=5V, I=V_{DD}/R_{Total}$ <sup>[7]</sup>
			80		$\Omega$	$V_{DD}=2.7V, I=V_{DD}/R_{Total}$ <sup>[7]</sup>
Wiper Current	$I_W$	-1		1	mA	
<b>Divider Mode</b>						
Resolution	N	8			Bits	
Different Non Linearity <sup>[2]</sup>	DNL	-1	±0.4	+1	LSB	
Integral Non Linearity <sup>[2]</sup>	INL	-1	±0.2	+1	LSB	
Temperature Coefficient <sup>[1]</sup>	$\Delta W / \Delta T$		+20		ppm/°C	Wiper at center
Full Scale Error	$V_{FSE}$	-1		0	LSB	Wiper at highest position
Zero Scale Error	$V_{ZSE}$	0		1	LSB	Wiper at lowest position
<b>Resistor Terminal</b>						
Voltage Range	$V_A, V_B, V_W$	$V_{SS}$		$V_{DD}$	V	
Terminal Capacitance <sup>[1]</sup>	$C_A, C_B$		30		pF	
Wiper Capacitance <sup>[1]</sup>			30		pF	
<b>Dynamic Characteristics <sup>[1]</sup></b>						
Bandwidth –3dB	$BW_{10K}$		1.5		MHz	$V_{DD}=5V, B = V_{SS}$
	$BW_{50K}$		300		KHz	Wiper at center
	$BW_{100K}$		200		KHz	
<b>Analog Output (Buffer enables)</b>						
Amp Output Current	$I_{OUT}$	3			mA	$V_O=1/2$ scale
Amp Output Resistance	$R_{out}$		1	10	$\Omega$	$I_L = 100\mu A$
Total Harmonic Distortion <sup>[1]</sup>	THD			0.08	%	$A = 2.5V, V_{DD}=5V, f=1kHz, V_{IN}=1V_{RMS}$
<b>Digital Inputs/Outputs</b>						
Input High Voltage	$V_{IH}$	$0.7 \times V_{DD}$			V	
Input Low Voltage	$V_{IL}$			$0.3 \times V_{DD}$	V	
Output Low Voltage	$V_{OL}$			0.4	V	$I_{OL}=2mA$



TABLE 12 – ELECTRICAL CHARACTERISTICS (Packaged parts) – Cont'd

PARAMETERS	SYMBOL	MIN.	TYP.	MAX.	UNITS	CONDITIONS <sup>[5]</sup>
Input Leakage Current	$I_{LI}$	-1		+1	$\mu A$	$\overline{CS}=V_{DD}, Vin=V_{SS} \sim V_{DD}$
Output Leakage Current	$I_{Lo}$	-1		+1	$\mu A$	$\overline{CS}=V_{DD}, Vin=V_{SS} \sim V_{DD}$
Input Capacitance <sup>[1]</sup>	$C_{IN}$		25		pF	$V_{DD}=5V, fc = 1Mhz$
Output Capacitance <sup>[1]</sup>	$C_{OUT}$		25		pF	$V_{DD}=5V, fc = 1Mhz$
<b>Power Requirements</b>						
Operating Voltage	$V_{DD}$	2.7		5.5	V	
Operating Current	$I_{DDR}, I_{DDW}$		1	2	mA	All operations
Standby Current	$I_{SA}$ <sup>[3]</sup>		0.5	1	mA	Buffer = ON $\overline{CS} = HIGH, no load$
	$I_{SB}$ <sup>[4]</sup>		0.1	1	$\mu A$	Buffer = OFF $\overline{CS} = HIGH, no load$
Power Supply Rejection Ratio	PSRR			1	LSB/V	$V_{DD}=5V \pm 10\%$ , Wiper at center

## Notes:

<sup>[1]</sup> Not subject to production test.

<sup>[2]</sup>  $LSB = (R_A/V_A - R_B/V_B) / (T - 1)$ ;  $DNL = (V_i - V_{i+1}) / LSB + 1$  (if increment) or  $= (V_i - V_{i+1}) / LSB - 1$  (if decrement);  $INL = (V_i - i*LSB) / LSB$ ; where  $i = [0, (T - 1)]$  and  $T =$  # of taps of the device.

<sup>[3]</sup> WMS7101 only.

<sup>[4]</sup> WMS7100 only.

<sup>[5]</sup> Conditions:  $V_{CC} = 2.7$  to  $5.5V$ ,  $T = 25^\circ C$  and timing measured at 50% level, unless stated.

<sup>[6]</sup> Only guarantee by design.

<sup>[7]</sup>  $R_{total}$  = end-to-end resistance.

# WMS7100 / 7101



## 10.1 TEST CIRCUITS

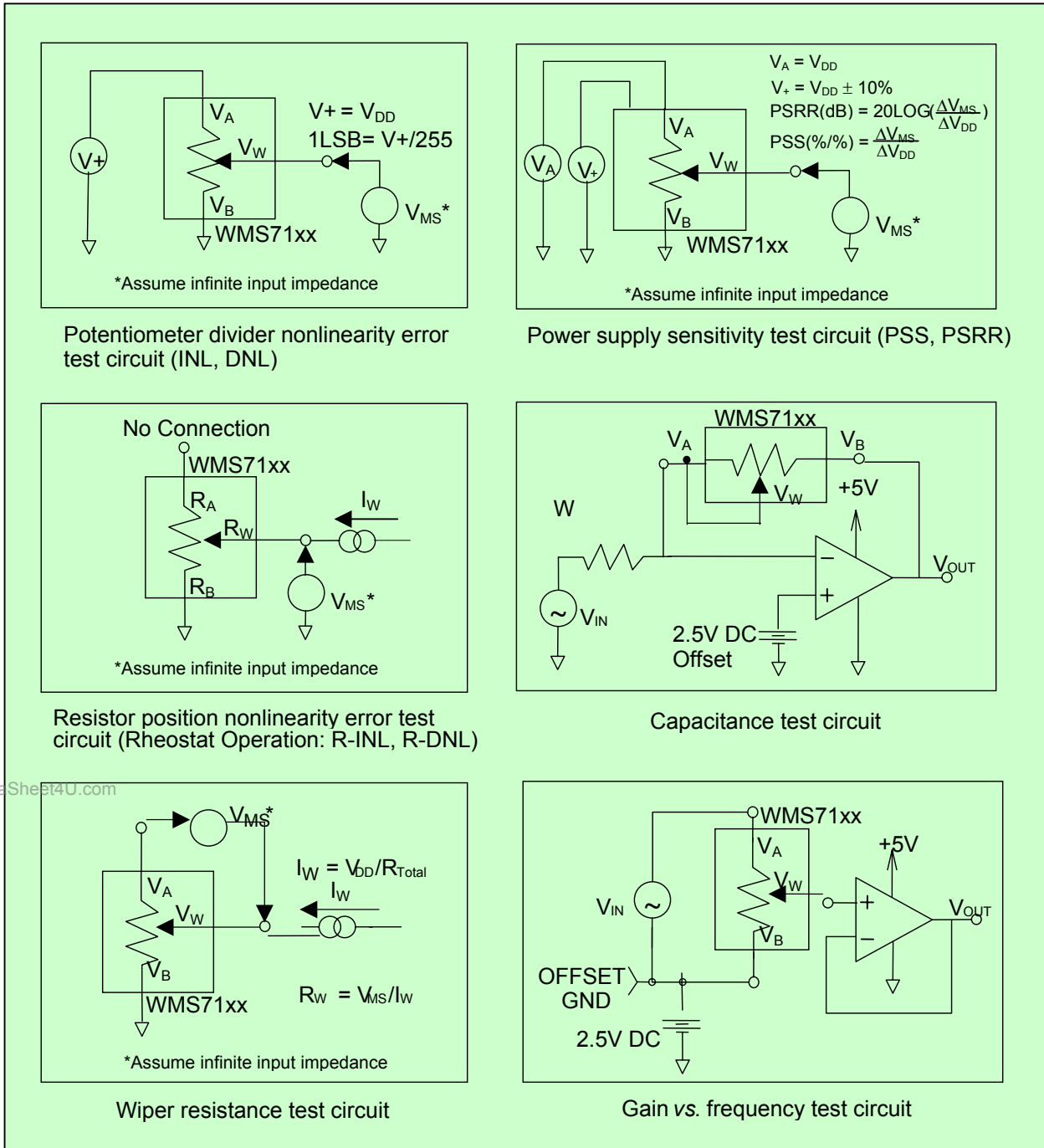

FIGURE 4 – TEST CIRCUITS



## 11. TYPICAL APPLICATION CIRCUITS

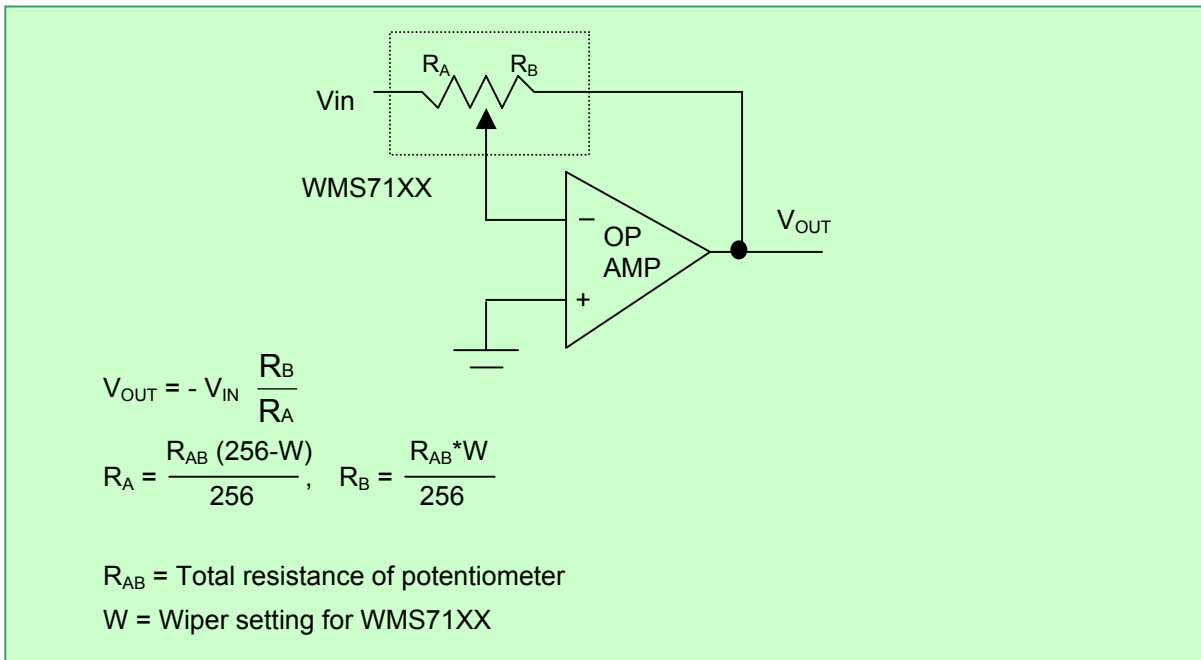

FIGURE 5 – PROGRAMMABLE INVERTING GAIN AMPLIFIER USING THE WMS7100/7101

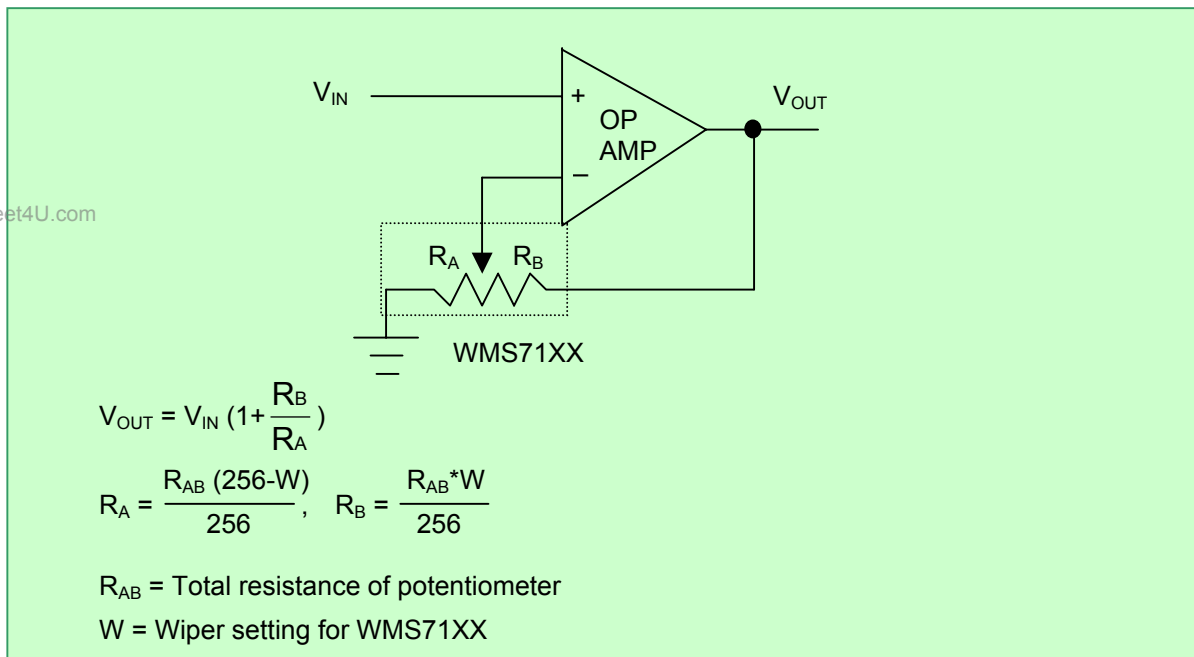

FIGURE 6 – PROGRAMMABLE NON-INVERTING GAIN AMPLIFIER USING THE WMS7100/7101

# WMS7100 / 7101

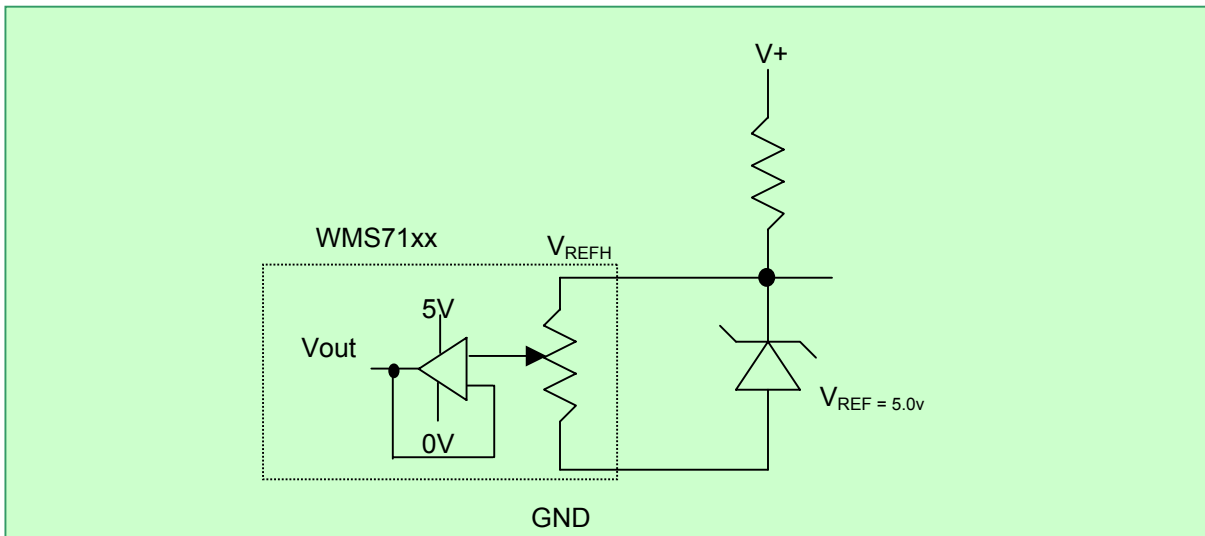

FIGURE 7 – WMS7101 TRIMMING VOLTAGE REFERENCE

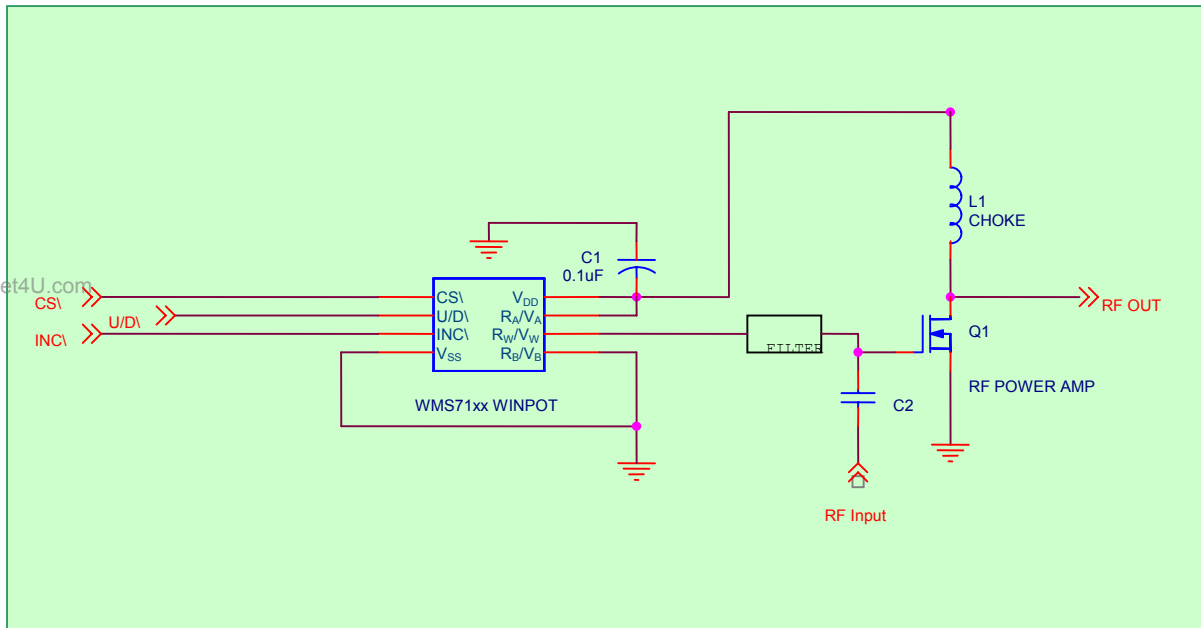

FIGURE 8 – WMS7101 RF AMP CONTROL



**WMS7100 / 7101****11.1. LAYOUT CONSIDERATIONS**

Use a 0.1 $\mu$ F bypass capacitor as close as possible to the  $V_{DD}$  pin. This is recommended for best performance. Often this can be done by placing the surface mount capacitor on the bottom side of the PC board, directly between the  $V_{DD}$  and  $V_{SS}$  pins. Care should be taken to separate the analog and digital traces. Sensitive traces should not run under the device or close to the bypass capacitors.

A dedicated plane for analog ground helps in reducing ground noise for sensitive analog signals.

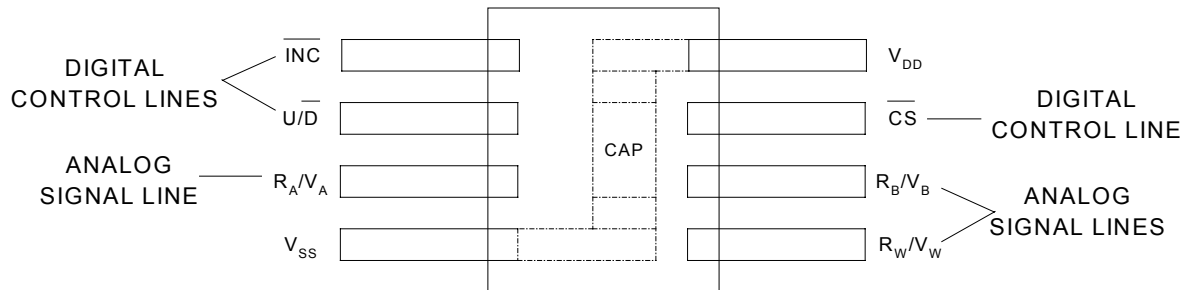

**FIGURE 9 – WMS7100/7101 LAYOUT**

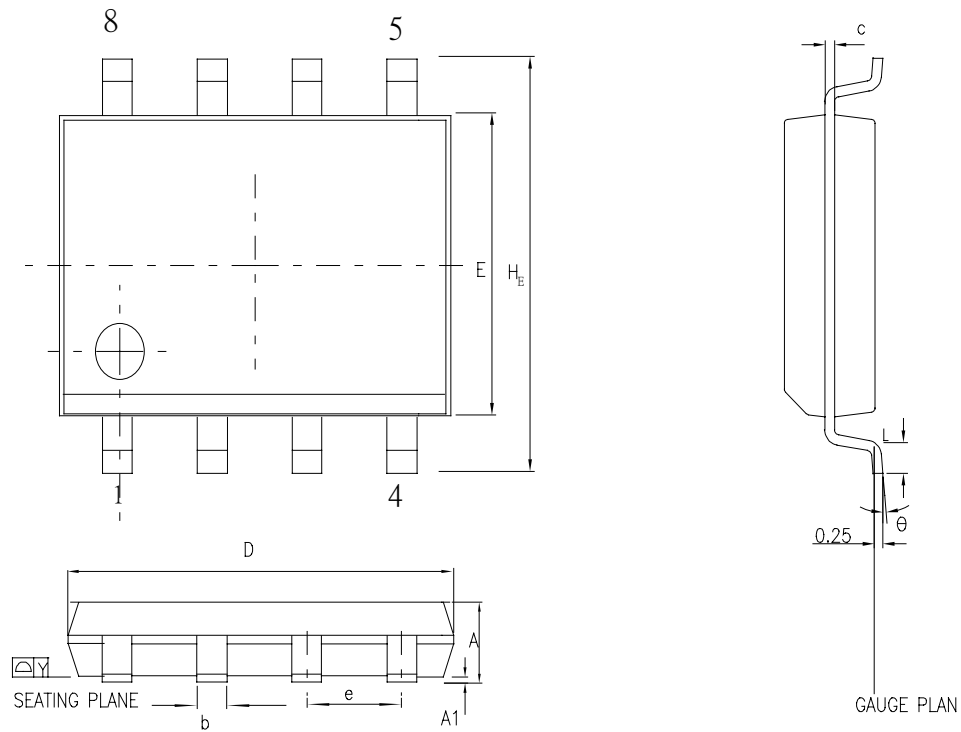
**12. PACKAGE DRAWINGS AND DIMENSIONS**

Control demensions are in milimeters .

SYMBOL	DIMENSION IN MM		DIMENSION IN INCH	
	MIN.	MAX.	MIN.	MAX.
A	1.35	1.75	0.053	0.069
A1	0.10	0.25	0.004	0.010
b	0.33	0.51	0.013	0.020
c	0.19	0.25	0.008	0.010
E	3.80	4.00	0.150	0.157
D	4.80	5.00	0.188	0.196
e	1.27 BSC		0.050 BSC	
H <sub>E</sub>	5.80	6.20	0.228	0.244
Y	— 0.10		— 0.004	
L	0.40	1.27	0.016	0.050
θ	0	10	0	10

**FIGURE 10: 8L 150MIL SOIC**

# WMS7100 / 7101

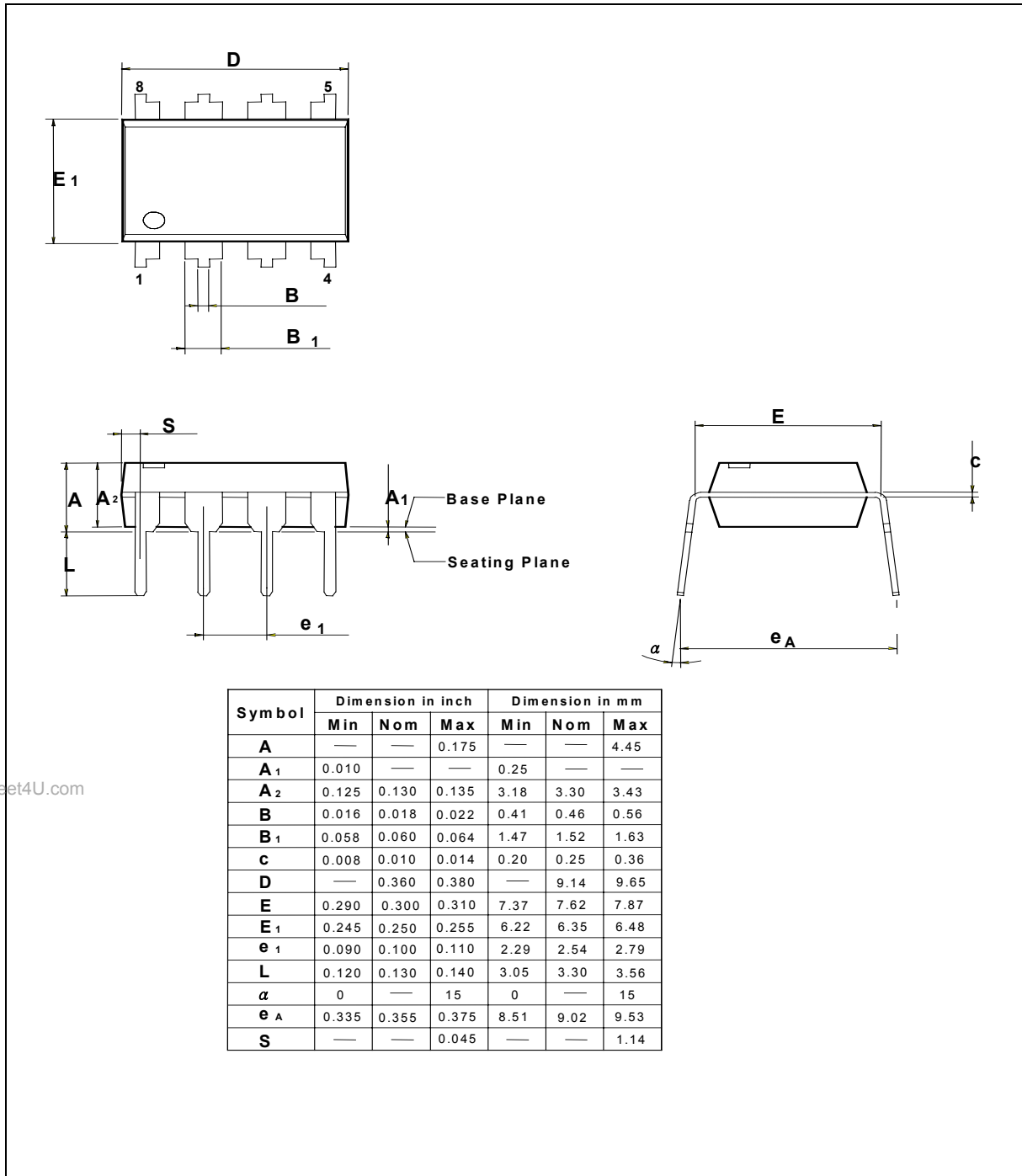

FIGURE 11: 8L 300MIL PDIP

# WMS7100 / 7101

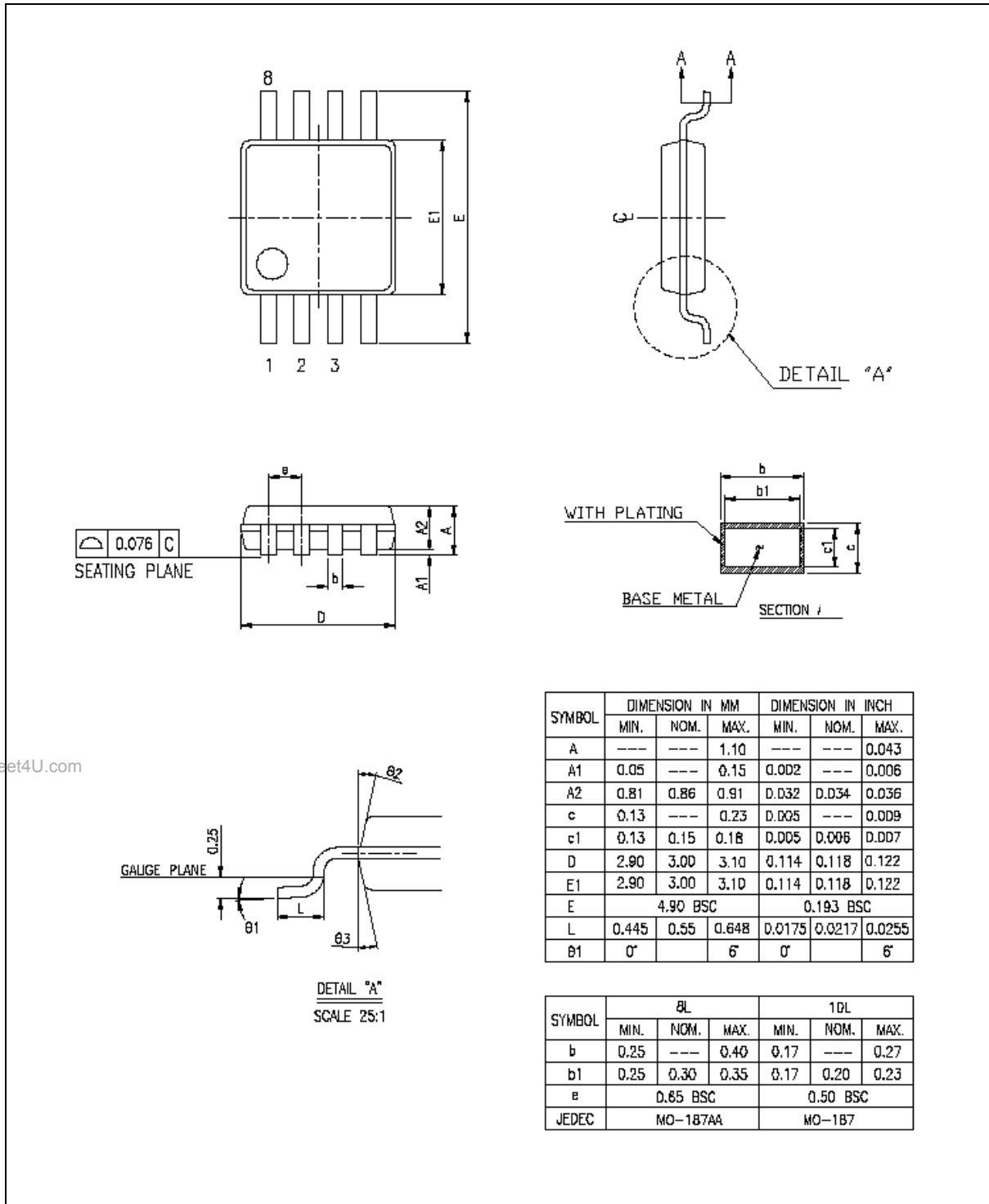

FIGURE 12: 8L 3MM MSOP

# WMS7100 / 7101



## 13. ORDERING INFORMATION

Winbond's WinPot Part Number Description:

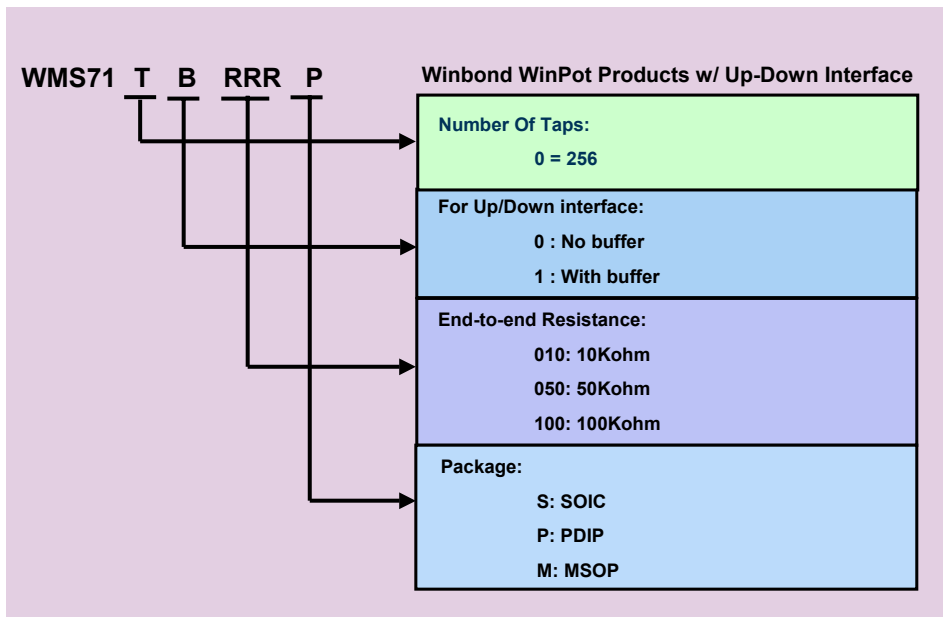

Output Buffer	End-to-End Resistance	SOIC	PDIP	MSOP
NO	10K	WMS71000 <b>10S</b>	WMS71000 <b>10P</b>	WMS71000 <b>10M</b>
	50K	WMS71000 <b>50S</b>	WMS71000 <b>50P</b>	WMS71000 <b>50M</b>
	100K	WMS7100 <b>100S</b>	WMS7100 <b>100P</b>	WMS7100 <b>100M</b>
YES	10K	WMS71010 <b>10S</b>	WMS71010 <b>10P</b>	WMS71010 <b>10M</b>
	50K	WMS71010 <b>50S</b>	WMS71010 <b>50P</b>	WMS71010 <b>50M</b>
	100K	WMS7101 <b>100S</b>	WMS7101 <b>100P</b>	WMS7101 <b>100M</b>

Notes:

Part number with white background: Available for sampling and mass production.

Part numbers with shaded background: Call factory for availability.

For the latest product information, access Winbond's worldwide website at <http://www.winbond-usa.com>

**14. VERSION HISTORY**

VERSION	DATE	DESCRIPTION
1.0	July 2003	Initial issue

The contents of this document are provided only as a guide for the applications of Winbond products. Winbond makes no representation or warranties with respect to the accuracy or completeness of the contents of this publication and reserves the right to discontinue or make changes to specifications and product descriptions at any time without notice. No license, whether express or implied, to any intellectual property or other right of Winbond or others is granted by this publication. Except as set forth in Winbond's Standard Terms and Conditions of Sale, Winbond assumes no liability whatsoever and disclaims any express or implied warranty of merchantability, fitness for a particular purpose or infringement of any Intellectual property.

Winbond products are not designed, intended, authorized or warranted for use as components in systems or equipments intended for surgical implantation, atomic energy control instruments, airplane or spaceship instruments, transportation instruments, traffic signal instruments, combustion control instruments, or for other applications intended to support or sustain life. Further, Winbond products are not intended for applications wherein failure of Winbond products could result or lead to a situation wherein personal injury, death or severe property or environmental injury could occur.

www.DataSheet4U.com

**Headquarters**

No. 4, Creation Rd. III  
Science-Based Industrial Park,  
Hsinchu, Taiwan  
TEL: 886-3-5770066  
FAX: 886-3-5665577  
<http://www.winbond.com.tw/>

**Winbond Electronics Corporation America**

2727 North First Street, San Jose,  
CA 95134, U.S.A.  
TEL: 1-408-9436666  
FAX: 1-408-5441797  
<http://www.winbond-usa.com/>

**Winbond Electronics (Shanghai) Ltd.**

27F, 299 Yan An W. Rd. Shanghai,  
200336 China  
TEL: 86-21-62365999  
FAX: 86-21-62356998

**Taipei Office**

9F, No. 480, Pueiguan Rd.  
Neihu District  
Taipei, 114 Taiwan  
TEL: 886-2-81777168  
FAX: 886-2-87153579

**Winbond Electronics Corporation Japan**

7F Daini-ueno BLDG. 3-7-18  
Shinyokohama Kohokuku,  
Yokohama, 222-0033  
TEL: 81-45-4781881  
FAX: 81-45-4781800

**Winbond Electronics (H.K.) Ltd.**

Unit 9-15, 22F, Millennium City,  
No. 378 Kwun Tong Rd.,  
Kowloon, Hong Kong  
TEL: 852-27513100  
FAX: 852-27552064

Please note that all data and specifications are subject to change without notice.  
All the trademarks of products and companies mentioned in this datasheet belong to their respective owners.  
This product incorporates SuperFlash® technology licensed from SST.