

3 YEAR
WARRANTY



Ω OMEGA® User's Guide

**Shop online at
omega.com®**

**e-mail: info@omega.com
For latest product manuals:
omegamanual.info**



MADE IN UNITED KINGDOM



OS150 USB 2.2 IR Temperature Sensors



OMEGAnet® Online Service
omega.com

Internet e-mail
info@omega.com

Servicing North America:

U.S.A.:
ISO 9001 Certified
One Omega Drive, Box 4047
Stamford CT 06907-0047
Tel: (203) 359-1660
FAX: (203) 359-7700
e-mail: info@omega.com

Canada:
976 Bergar
Laval (Quebec) H7L 5A1, Canada
Tel: (514) 856-6928
FAX: (514) 856-6886
e-mail: info@omega.ca

For immediate technical or application assistance:

U.S.A. and Canada: Sales Service: 1-800-826-6342/1-800-TC-OMEGA®
Customer Service: 1-800-622-2378/1-800-622-BEST®
Engineering Service: 1-800-872-9436/1-800-USA-WHEN®

Mexico:
En Español: (001) 203-359-7803
FAX: (001) 203-359-7807
e-mail: espanol@omega.com
info@omega.com.mx

Servicing Europe:

Benelux: Managed by the United Kingdom Office
Toll-Free: 0800 099 3344 TEL: +31 20 347 21 21
FAX: +31 20 643 46 43 e-mail: sales@omegaeng.nl

Czech Republic: Frystatska 184, 733 01 Karviná, Czech Republic
Tel: +420 (0)59 6311899
FAX: +420 (0)59 6311114
Toll Free: 0800-1-66342
e-mail: info@omegashop.cz

Germany/Austria: Daimlerstrasse 26, D-75392 Deckenpfronn, Germany
Tel: +49 (0)7056 9398-0
FAX: +49 (0)7056 9398-29
Toll Free in Germany: 0800 639 7678
e-mail: info@omega.de

United Kingdom: One Omega Drive, River Bend Technology Centre
ISO 9002 Certified Northbank, Irlam, Manchester
M44 5BD United Kingdom
Tel: +44 (0)161 777 6611
FAX: +44 (0)161 777 6622
Toll Free in United Kingdom: 0800-488-488
e-mail: sales@omega.co.uk

It is the policy of OMEGA Engineering, Inc. to comply with all worldwide safety and EMC/EMI regulations that apply. OMEGA is constantly pursuing certification of its products to the European New Approach Directives. OMEGA will add the CE mark to every appropriate device upon certification.

The information contained in this document is believed to be correct, but OMEGA accepts no liability for any errors it contains, and reserves the right to alter specifications without notice.

WARNING: These products are not designed for use in, and should not be used for, human applications.

OS150 USB 2.2 Series non-contact infrared sensors measure temperatures from 45°C to 2000°C and provide a linear 0 to 20 or 4 to 20 mA output. The signal is compatible with almost any indicator, controller, recorder, data logger etc., without the need for special interfacing or signal conditioning. They are especially suited to low-emissivity targets such as steel rollers and other metal surfaces, even at low temperatures.

SPECIFICATION

GENERAL

Temperature Range	LT: 45°C* to 300°C (OS151-2USB-LT only) PT: 100 to 400°C (OS151-2USB-PT only) MT: 250°C to 1000°C HT: 450°C to 2000°C
Output	4 to 20 mA, 0 to 20 mA (linear with temperature, adjustable via software)
Accuracy*	±1% of reading or ±2°C whichever is greater
Repeatability*	±0.5% of reading or ±0.5°C whichever is greater
Emissivity	0.1 to 1.0, adjustable via software
Response Time	≥ 240 ms (90% response)
Field-of-View	15:1 (OS151-2USB-LT or PT) 25:1 (OS251-2USB-MT or HT) 75:1 (OS751-2USB-MT or HT) ø7.5mm @ 500mm (OS801-2USB-MT or HT)
Spectral Response	2.0 to 2.4 µm
Supply Voltage	24 V DC (26 V DC max.)
Sensor Voltage	11 V DC min.
Maximum Loop Impedance	900 ohms @ 24 V DC

MECHANICAL

Construction	Stainless Steel
Dimensions	25 mm diameter x 106.5 mm
Output Cable Length	1 m (longer cable available to order)
USB Cable Length	1 m
Weight with Output Cable	175 g

ENVIRONMENTAL

Environmental Rating	IP65
Ambient Temperature Range	0°C to 70°C
Relative Humidity	95% maximum non-condensing
Electromagnetic Compatibility	EN61326-1:2006 Industrial (analogue output only) EN61326-1:2006 Basic (USB)

* Object temperature > T_{min} (see graph of Minimum Measurable Temperature on page 9)

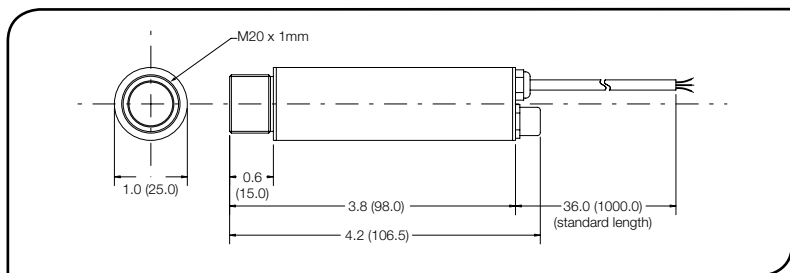

ACCESSORIES

A range of accessories to suit different applications and industrial environments is available. These may be ordered at any time and added on-site. The accessories consist of the following parts .

- Fixed mounting bracket
- Adjustable mounting bracket
- Air purge collar
- Laser sighting tool

OPTIONS

The following options are available. Options are factory installed and must be ordered with the OS150 USB 2.2 sensor.

- Air/water cooled housing
- Certificate of calibration
- Longer cable (30 m max.)

OPTICAL CHART

The optical chart below indicates the nominal target spot diameter at any given distance from the sensing head and assumes 90% energy.

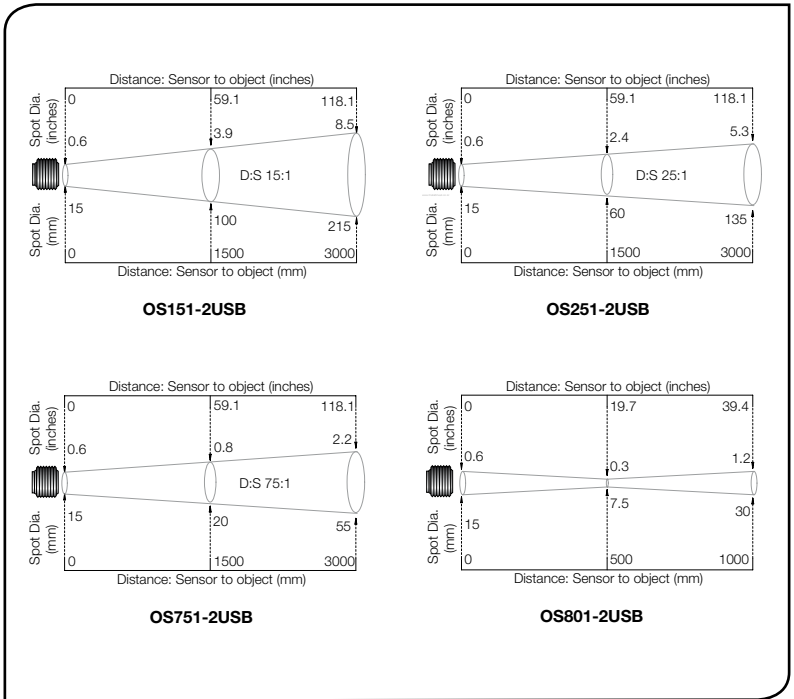

INSTALLATION

The installation process consists of the following stages:

- Preparation
- Mechanical installation
- Electrical installation

Please read the following sections thoroughly before proceeding with the installation.

PREPARATION

Ensure that the sensor is positioned so that it is focused on the target only.

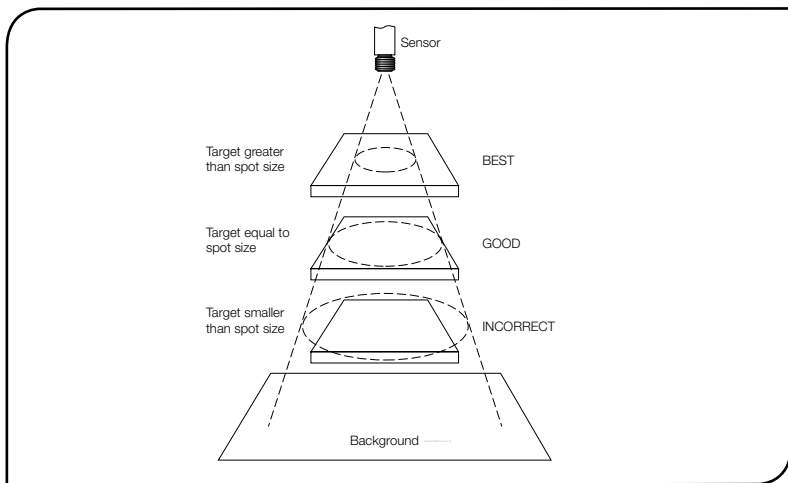

DISTANCE AND SPOT SIZE

The size of the area (spot size) to be measured determines the distance between the sensor and the target. The spot size must not be larger than the target. The sensor should be mounted so that the measured spot size is smaller than the target.

REFLECTIONS

The sensor must be installed in a location where energy from lamps, heaters and sunlight cannot be reflected from the target into the lens. The use of shields may help in this respect. For further information and assistance contact Omega.

AMBIENT TEMPERATURE

The sensor is designed to operate in ambient temperatures from 0°C to 70°C. For ambient temperatures above 70°C, an air/water-cooled housing will be required.

Avoid thermal shock. Allow 20 minutes for the unit to adjust to large changes in ambient temperature.

ATMOSPHERIC QUALITY

Smoke, fumes or dust can contaminate the lens and cause errors in temperature measurement. In these types of environment the air purge collar should be used to help keep the lens clean.

ELECTRICAL INTERFERENCE

To minimise electromagnetic interference or 'noise', the sensor should be mounted away from motors, generators and such like.

WIRING

Check the distance between the sensor and the indicating/controlling device. If necessary, the OS150 USB 2.2 sensor can be ordered with a longer output cable attached.

MECHANICAL INSTALLATION

All sensors come with a 1 m cable and a mounting nut. The sensor can be mounted on brackets or cut outs of your own design, or you can use the fixed and adjustable mounting bracket accessories which are shown below.

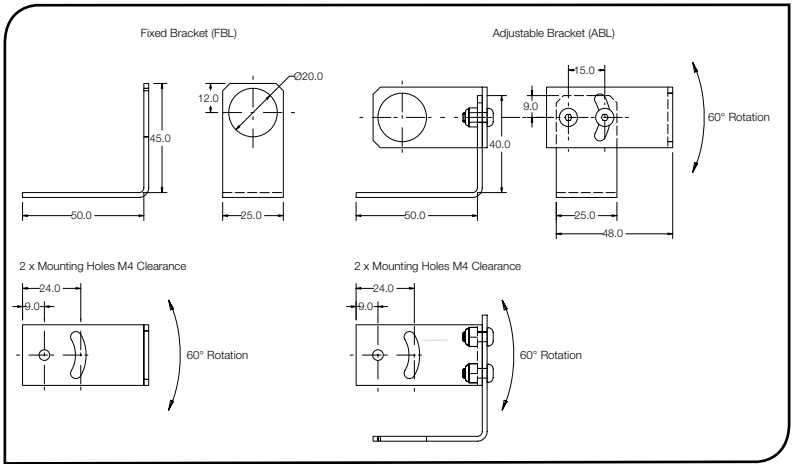

AIR/WATER COOLED HOUSING

The air/water cooled housing shown below allows the sensor to withstand high ambient temperatures. It is equipped with two 1/8" BSP fittings. Water temperature should be 10°C to 27°C for efficient cooling. Chilled water below 10°C is not recommended. To avoid condensation, the air purge collar, supplied with the cooled housing, should be used.

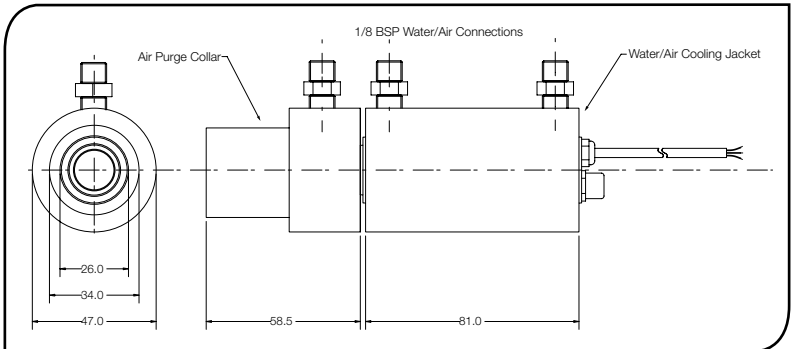

AIR PURGE COLLAR

The air purge collar below is used to keep dust, fumes, moisture, and other contaminants away from the lens. It must be screwed in fully. Air flows into the 1/8" BSP fitting and out of the front aperture. Air flow should be no more than 5 to 15 litres/min.

Clean or 'instrument' air is recommended.

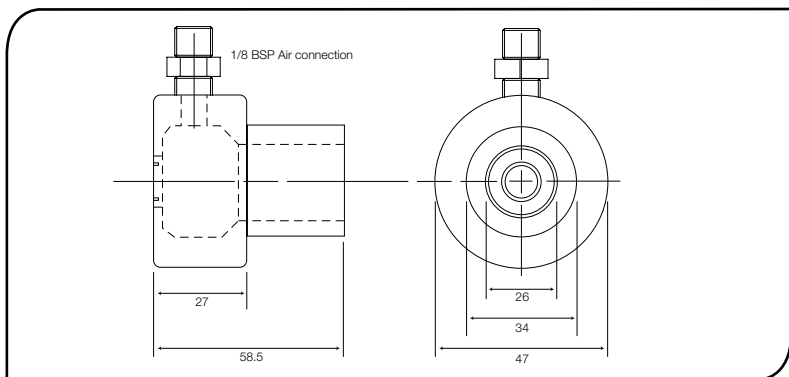

ELECTRICAL INSTALLATION

The sensor to electronics cable is a 1 m PTFE cable. One end is attached, at the factory, to the sensor head. The other end has two pairs of wires and a shield (ground) wire.

WIRING

The OS150 USB 2.2 sensor can be used in three different ways as shown below. To use the analogue output, connect the OS150 USB 2.2 sensor to the controller/indicator with the 24 V DC power supply using the following table and connection diagram as a guide. The maximum loop impedance is 900 ohms. **Note: The OS150 USB 2.2 sensor must be grounded at only one point, either the cable shield or the sensor housing.**

Wire No.	Wire Colour	Function	Tag
1	Red	Power supply +	PWR +
2	Blue	Power supply -	PWR -
3	Yellow	Signal +	OP +
4	Green	Signal -	OP -
5	Bare	Shield ground	

Alternatively, to use the USB output, connect the OS150 USB 2.2 sensor to a PC using the cable provided. No external power supply is required when using the USB output. The OS150 USB 2.2 sensor can also be used with both the analogue output and USB connected, provided that the negative terminal of the 24 V DC power supply being used is not grounded. **Note: The OmegaSoft software must be installed before connecting the sensor to a PC.**

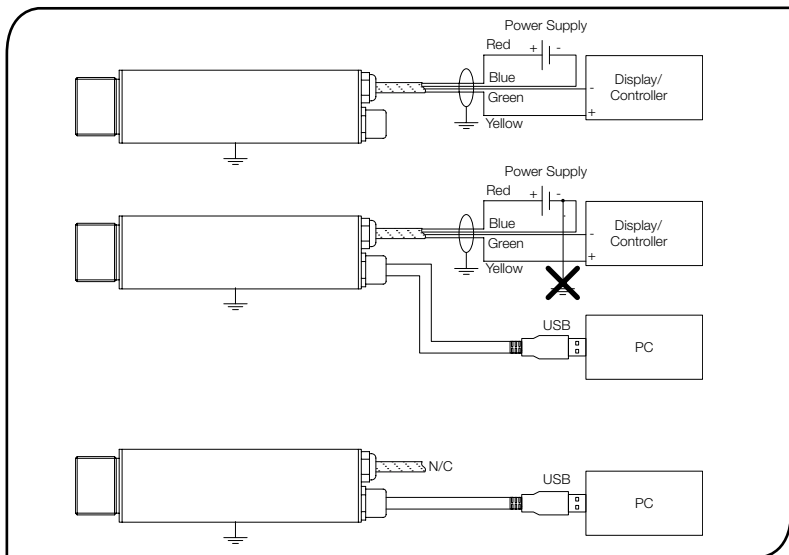

OMEGASOFT SOFTWARE SYSTEM REQUIREMENTS

- OmegaSoft software is designed to run under Windows. Suitable versions are Windows 2000, Windows XP, Windows Vista and Windows 7.
- The recommended minimum computer specification is:
Intel Pentium processor
VGA display with 640x480 resolution
USB 2.0 port

INSTALLATION

1. Insert the disk provided
2. Installer should run automatically (if not, select the appropriate drive and double click on Setup.exe)
3. Follow the on-screen instructions

NOTE Do not connect the OS150 USB 2.2 Sensor to the PC before the software is installed

CONNECTING THE OS150 USB 2.2 SENSOR TO A PC

1. Connect the circular connector on the USB cable provided to the OS150 USB 2.2 sensor
2. Connect the USB A connector on the USB cable provided to an available USB 2.0 port
3. Double click on the OmegaSoft desktop icon

CONFIGURATION

- Setting Temperature Units
Temperature units can be set on the main temperature panel by pressing °C or °F.

- Setting Output Processing

The temperature range for the analogue output, the averaging period and the peak/valley hold processing can be set by using the main program menu to select: [Setup] → [Output Processing]

The temperatures corresponding to the lower and upper limits of the analogue output can then be set as follows:

Model	Lower Limit	Upper Limit	Minimum Span	Maximum Span
LT	45°C	300°C	100°C	255°C
PT	100°C	400°C	100°C	300°C
MT	250°C	1000°C	100°C	750°C
HT	450°C	2000°C	100°C	1550°C

The output type can be selected as either 0 mA to 20 mA or 4 mA to 20 mA.

To minimise the the effects of temperature fluctuations, noise etc on the output signal, the averaging period can be set between 0 and 60 seconds.

If required, Hold Processing can be applied by setting hold mode to Peak Hold or Valley Hold and setting a hold period between 0 and 1200 seconds.

- Setting Target Emissivity

To set an emissivity value for the OS150 USB 2.2 sensor, use the main program menu to select:

[Setup] → [Emissivity]

Emissivity can then be set to a value between 0.1 and 1.0, or selected from a pre-set list of materials by selecting [Data].

MINIMUM MEASURABLE TEMPERATURE (OS151-2USB-LT only)

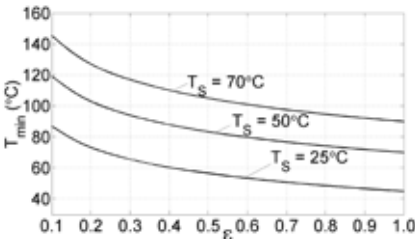

Graph showing the minimum measurable object temperature (T_{min}), determined by surface emissivity (ϵ) and sensor temperature (T_s).

- Setting Reflected Temperature Compensation

To enable and set reflected temperature compensation, use the main program menu to select:

[Setup] → [Reflection Compensation]

Reflected temperature compensation can be enabled/disabled using [Compensate for Reflected Temperature], and when enabled the temperature value can be set between 45 and 2000°C, depending on the model selected.

To store the changes in the sensor's memory, select [File] → [Save sensor processing parameters].

OPERATION

Once the sensor is in position and the appropriate power, air, water, and cable connections are secure, the system is ready for continuous operation by completing the following simple steps:

1. Turn on the power supply
2. Turn on the instrument or PC
3. Read / monitor the temperature

IMPORTANT

Be aware of the following when using the sensor:

- If the sensor is exposed to significant changes in ambient temperature (hot to cold, or cold to hot), allow 20 minutes for the temperature to stabilise before taking or recording measurements.
- Do not operate the sensor near large electromagnetic fields (e.g. around arc welders or induction heaters) or where energy from lamps, heaters and sunlight could be reflected into the lens.
Electromagnetic interference can cause measurement errors.
- Wire must be connected only to the appropriate terminals.

MAINTENANCE

Our customer service representatives are available for application assistance, calibration, repair, and solutions to specific problems. Contact our Service Department before returning any equipment. In many cases, problems can be solved over the telephone. If the sensor is not performing as it should, try to match the symptom below to the problem. If the table does not help, call Omega for further advice.

TROUBLESHOOTING

Symptom	Probable Cause	Solution
No output	No power to sensor	Check power supply
Erroneous temperature	Incorrect wire connection	Check wire colour codes
Erroneous temperature	Faulty sensor cable	Verify cable continuity
Erroneous temperature	Field of view obstruction	Remove obstruction

LENS CLEANING

Keep the lens clean at all times. Any foreign matter on the lens would affect measurement accuracy. Blow off loose particles (if not using the air purge accessory) with an air 'puffer'.

WARRANTY/DISCLAIMER

OMEGA ENGINEERING, INC. warrants this unit to be free of defects in materials and workmanship for a period of **37 months** from date of purchase. OMEGA's WARRANTY adds an additional one (1) month grace period to the normal **three (3) year product warranty** to cover handling and shipping time. This ensures that OMEGA's customers receive maximum coverage on each product.

If the unit malfunctions, it must be returned to the factory for evaluation. OMEGA's Customer Service Department will issue an Authorized Return (AR) number immediately upon phone or written request. Upon examination by OMEGA, if the unit is found to be defective, it will be repaired or replaced at no charge. OMEGA's WARRANTY does not apply to defects resulting from any action of the purchaser, including but not limited to mishandling, improper interfacing, operation outside of design limits, improper repair, or unauthorized modification. This WARRANTY is VOID if the unit shows evidence of having been tampered with or shows evidence of having been damaged as a result of excessive corrosion; or current, heat, moisture or vibration; improper specification; misapplication; misuse or other operating conditions outside of OMEGA's control. Components in which wear is not warranted, include but are not limited to contact points, fuses, and triacs.

OMEGA is pleased to offer suggestions on the use of its various products. However, OMEGA neither assumes responsibility for any omissions or errors nor assumes liability for any damages that result from the use of its products in accordance with information provided by OMEGA, either verbal or written. OMEGA warrants only that the parts manufactured by the company will be as specified and free of defects. OMEGA MAKES NO OTHER WARRANTIES OR REPRESENTATIONS OF ANY KIND WHATSOEVER, EXPRESSED OR IMPLIED, EXCEPT THAT OF TITLE, AND ALL IMPLIED WARRANTIES INCLUDING ANY WARRANTY OF MERCHANTABILITY AND FITNESS FOR A PARTICULAR PURPOSE ARE HEREBY DISCLAIMED. LIMITATION OF LIABILITY: The remedies of purchaser set forth herein are exclusive, and the total liability of OMEGA with respect to this order, whether based on contract, warranty, negligence, indemnification, strict liability or otherwise, shall not exceed the purchase price of the component upon which liability is based. In no event shall OMEGA be liable for consequential, incidental or special damages.

CONDITIONS: Equipment sold by OMEGA is not intended to be used, nor shall it be used: (1) as a "Basic Component" under 10 CFR 21 (NRC), used in or with any nuclear installation or activity; or (2) in medical applications or used on humans. Should any Product(s) be used in or with any nuclear installation or activity, medical application, used on humans, or misused in any way, OMEGA assumes no responsibility as set forth in our basic WARRANTY/DISCLAIMER language, and, additionally, purchaser will indemnify OMEGA and hold OMEGA harmless from any liability or damage whatsoever arising out of the use of the Product(s) in such a manner.

RETURN REQUESTS/INQUIRIES

Direct all warranty and repair requests/inquiries to the OMEGA Customer Service Department. BEFORE RETURNING ANY PRODUCT(S) TO OMEGA, PURCHASER MUST OBTAIN AN AUTHORIZED RETURN (AR) NUMBER FROM OMEGA'S CUSTOMER SERVICE DEPARTMENT (IN ORDER TO AVOID PROCESSING DELAYS). The assigned AR number should then be marked on the outside of the return package and on any correspondence.

The purchaser is responsible for shipping charges, freight, insurance and proper packaging to prevent breakage in transit.

FOR **WARRANTY** RETURNS, please have the following information available BEFORE contacting OMEGA:

1. Purchase Order number under which the product was PURCHASED,
2. Model and serial number of the product under warranty, and
3. Repair instructions and/or specific problems relative to the product.

FOR **NON-WARRANTY** REPAIRS, consult OMEGA for current repair charges. Have the following information available BEFORE contacting OMEGA:

1. Purchase Order number to cover the COST of the repair,
2. Model and serial number of the product, and
3. Repair instructions and/or specific problems relative to the product.

OMEGA's policy is to make running changes, not model changes, whenever an improvement is possible. This affords our customers the latest in technology and engineering.

OMEGA is a registered trademark of OMEGA ENGINEERING, INC.

© Copyright 2011 OMEGA ENGINEERING, INC. All rights reserved. This document may not be copied, photocopied, reproduced, translated, or reduced to any electronic medium or machine-readable form, in whole or in part, without the prior written consent of OMEGA ENGINEERING, INC.

Where Do I Find Everything I Need for Process Measurement and Control? **OMEGA...Of Course!** *Shop online at omega.comSM*

TEMPERATURE

- ☑ Thermocouple, RTD & Thermistor Probes, Connectors, Panels & Assemblies
- ☑ Wire: Thermocouple, RTD & Thermistor
- ☑ Calibrators & Ice Point References
- ☑ Recorders, Controllers & Process Monitors
- ☑ Infrared Pyrometers

PRESSURE, STRAIN AND FORCE

- ☑ Transducers & Strain Gages
- ☑ Load Cells & Pressure Gages
- ☑ Displacement Transducers
- ☑ Instrumentation & Accessories

FLOW/LEVEL

- ☑ Rotameters, Gas Mass Flowmeters & Flow Computers
- ☑ Air Velocity Indicators
- ☑ Turbine/Paddlewheel Systems
- ☑ Totalizers & Batch Controllers

pH/CONDUCTIVITY

- ☑ pH Electrodes, Testers & Accessories
- ☑ Benchtop/Laboratory Meters
- ☑ Controllers, Calibrators, Simulators & Pumps
- ☑ Industrial pH & Conductivity Equipment

DATA ACQUISITION

- ☑ Data Acquisition & Engineering Software
- ☑ Communications-Based Acquisition Systems
- ☑ Plug-in Cards for Apple, IBM & Compatibles
- ☑ Data Logging Systems
- ☑ Recorders, Printers & Plotters

HEATERS

- ☑ Heating Cable
- ☑ Cartridge & Strip Heaters
- ☑ Immersion & Band Heaters
- ☑ Flexible Heaters
- ☑ Laboratory Heaters

ENVIRONMENTAL MONITORING AND CONTROL

- ☑ Metering & Control Instrumentation
- ☑ Refractometers
- ☑ Pumps & Tubing
- ☑ Air, Soil & Water Monitors
- ☑ Industrial Water & Wastewater Treatment
- ☑ pH, Conductivity & Dissolved Oxygen Instruments