

256K x 16 LOW VOLTAGE, 1.8V ULTRA LOW POWER CMOS STATIC RAM

NOVEMBER 2001

FEATURES

- High-speed access time: 70, 85, ns
- CMOS low power operation
 - 36 mW (typical) operating
 - 9 μ W (typical) CMOS standby
- Single 1.7V-1.95V V_{CC} power supply
- Fully static operation: no clock or refresh required
- Three state outputs
- Data control for upper and lower bytes
- Industrial temperature available
- Available in the 44-pin TSOP (Type II) and 48-pin mini BGA (7.2mm x 8.7mm)

DESCRIPTION

The *ISSI* IS62VV25616LL is a high-speed, 4,194,304 bit static RAMs organized as 262,144 words by 16 bits. They are fabricated using *ISSI*'s high-performance CMOS technology. This highly reliable process coupled with innovative circuit design techniques, yields high-performance and low power consumption devices.

For the IS62VV25616LL, when \overline{CE} is HIGH (deselected) or \overline{CE} is low and both \overline{LB} and \overline{UB} are HIGH, the device assumes a standby mode at which the power dissipation can be reduced down with CMOS input levels.

Easy memory expansion is provided by using Chip Enable and Output Enable inputs, \overline{CE} and \overline{OE} . The active LOW Write Enable (\overline{WE}) controls both writing and reading of the memory. A data byte allows Upper Byte (\overline{UB}) and Lower Byte (\overline{LB}) access.

The IS62VV25616LL is packaged in the JEDEC standard 44-pin TSOP (Type II) and 48-pin mini BGA (7.2mm x 8.7mm).

FUNCTIONAL BLOCK DIAGRAM

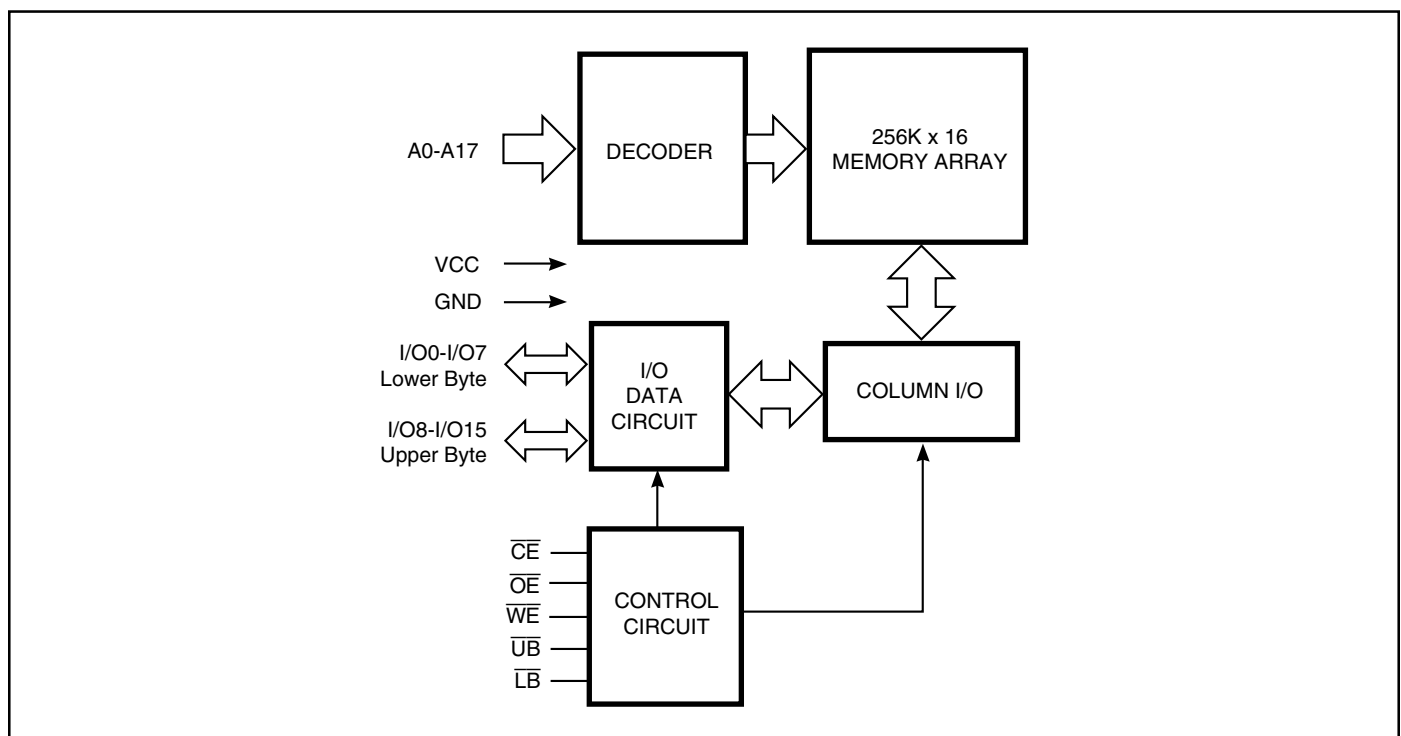

ISSI reserves the right to make changes to its products at any time without notice in order to improve design and supply the best possible product. We assume no responsibility for any errors which may appear in this publication. © Copyright 2001, Integrated Silicon Solution, Inc.

PIN CONFIGURATIONS

44-Pin TSOP (Type II)

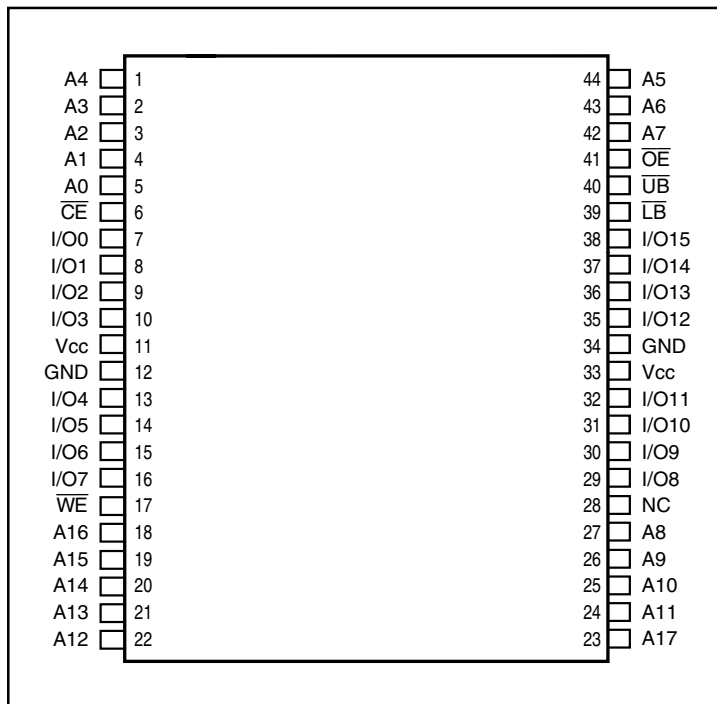

48-Pin mini BGA (7.2mm x 8.7mm)

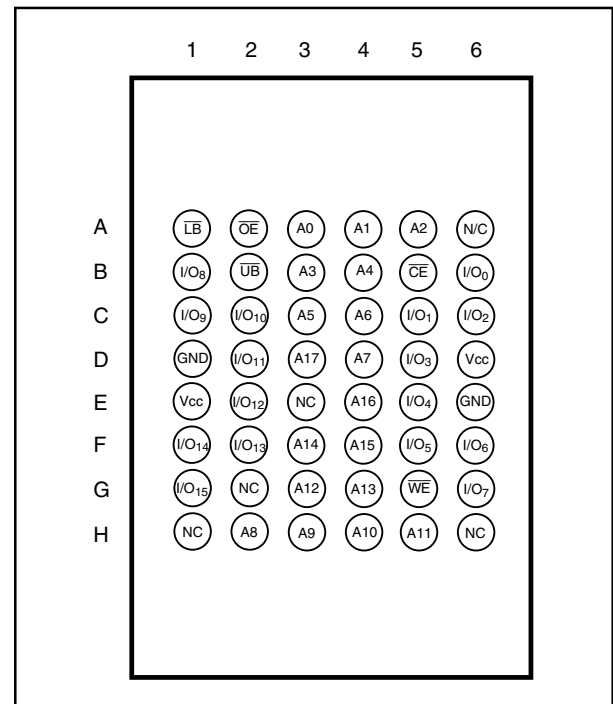

PIN DESCRIPTIONS

A0-A17	Address Inputs
I/O0-I/O15	Data Inputs/Outputs
CE	Chip Enable Input
OE	Output Enable Input
WE	Write Enable Input

LB	Lower-byte Control (I/O0-I/O7)
UB	Upper-byte Control (I/O8-I/O15)
NC	No Connection
Vcc	Power
GND	Ground

TRUTH TABLE

Mode	WE	CE	OE	LB	UB	I/O PIN		Vcc Current
						I/O0-I/O7	I/O8-I/O15	
Not Selected	X	H	X	X	X	High-Z	High-Z	Isb1, Isb2
	X	L	X	H	H	High-Z	High-Z	Isb1, Isb2
Output Disabled	H	L	H	X	X	High-Z	High-Z	Icc
	X	L	X	H	H	High-Z	High-Z	Isb1, Isb2
Read	H	L	L	L	H	DOUT	High-Z	Icc
	H	L	L	H	L	High-Z	DOUT	
	H	L	L	L	L	DOUT	DOUT	
Write	L	L	X	L	H	DIN	High-Z	Icc
	L	L	X	H	L	High-Z	DIN	
	L	L	X	L	L	DIN	DIN	

OPERATING RANGE

Range	Ambient Temperature	V _{CC}
Commercial	0°C to +70°C	1.7V - 1.95V
Industrial	-40°C to +85°C	1.7V - 1.95V

ABSOLUTE MAXIMUM RATINGS⁽¹⁾

Symbol	Parameter	Value	Unit
V _{TERM}	Terminal Voltage with Respect to GND	-0.2 to V _{CC} +0.3	V
T _{BIAS}	Temperature Under Bias	-40 to +85	°C
V _{CC}	V _{CC} Related to GND	-0.2 to +2.3	V
T _{STG}	Storage Temperature	-65 to +150	°C
P _T	Power Dissipation	1.0	W

Note:

1. Stress greater than those listed under ABSOLUTE MAXIMUM RATINGS may cause permanent damage to the device. This is a stress rating only and functional operation of the device at these or any other conditions above those indicated in the operational sections of this specification is not implied. Exposure to absolute maximum rating conditions for extended periods may affect reliability.

DC ELECTRICAL CHARACTERISTICS (Over Operating Range)

Symbol	Parameter	Test Conditions	Min.	Max.	Unit
V _{OH}	Output HIGH Voltage	I _{OH} = -0.1 mA	1.4	—	V
V _{OL}	Output LOW Voltage	I _{OL} = 0.1 mA	—	0.2	V
V _{IH}	Input HIGH Voltage		1.4	V _{CC} + 0.2	V
V _{IL} ⁽¹⁾	Input LOW Voltage		-0.3	0.4	V
I _{LI}	Input Leakage	GND ≤ V _{IN} ≤ V _{CC}	-1	1	μA
I _{LO}	Output Leakage	GND ≤ V _{OUT} ≤ V _{CC} , Outputs Disabled	-1	1	μA

Notes:

1. V_{IL} (min.) = -1.0V for pulse width less than 10 ns.

CAPACITANCE⁽¹⁾

Symbol	Parameter	Conditions	Max.	Unit
C _{IN}	Input Capacitance	V _{IN} = 0V	8	pF
C _{OUT}	Input/Output Capacitance	V _{OUT} = 0V	10	pF

Note:

1. Tested initially and after any design or process changes that may affect these parameters.

AC TEST CONDITIONS

Parameter	Unit
Input Pulse Level	0.4V to $V_{CC} - 0.2V$
Input Rise and Fall Times	5 ns
Input and Output Timing and Reference Level	0.9V
Output Load	See Figures 1 and 2

AC TEST LOADS

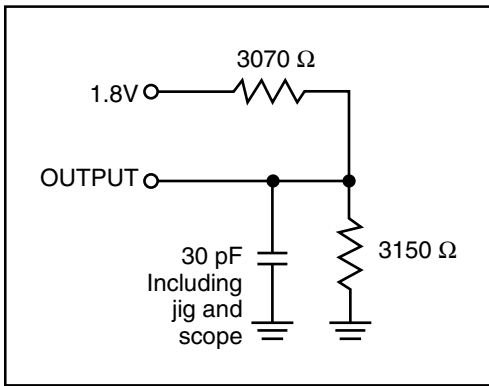

Figure 1

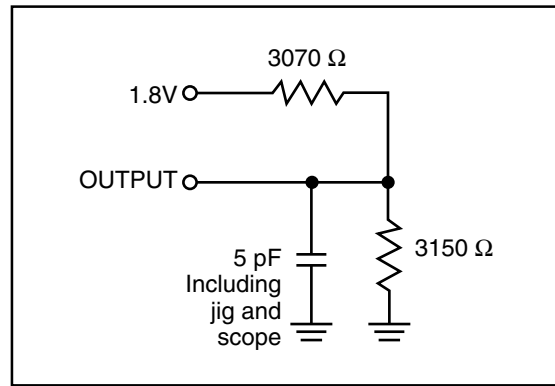

Figure 2

POWER SUPPLY CHARACTERISTICS⁽¹⁾ (Over Operating Range)

Symbol	Parameter	Test Conditions		-70		-85		Unit
				Min.	Max.	Min.	Max.	
I _{CC}	V _{CC} Dynamic Operating Supply Current	V _{CC} = Max., I _{OUT} = 0 mA, f = f _{MAX}	Com.	—	20	—	15	mA
			Ind.	—	25	—	20	
I _{CC1}	Operating Supply Current	V _{CC} = Max., I _{OUT} = 0 mA, f = 1 MHz	Com.	—	3	—	3	mA
			Ind.	—	3	—	3	
I _{SB1}	TTL Standby Current (TTL Inputs)	V _{CC} = Max., V _{IN} = V _{IH} or V _{IL} CE ≥ V _{IH} , f = 0	Com.	—	0.3	—	0.3	mA
			Ind.	—	0.3	—	0.3	
	OR							
	ULB Control	V _{CC} = Max., V _{IN} = V _{IH} or V _{IL} CE = V _{IL} , f = 0, UB = V _{IH} , LB = V _{IH}						
I _{SB2}	CMOS Standby Current (CMOS Inputs)	V _{CC} = Max., CE ≥ V _{CC} - 0.2V, V _{IN} ≥ V _{CC} - 0.2V, or V _{IN} ≤ 0.2V, f = 0	Com.	—	10	—	10	μA
			Ind.	—	10	—	10	
	OR							
	ULB Control	V _{CC} = Max., CE = V _{IL} V _{IN} ≤ 0.2V, f = 0; UB / LB = V _{CC} - 0.2V						

Note:

1. At f = f_{MAX}, address and data inputs are cycling at the maximum frequency, f = 0 means no input lines change.

READ CYCLE SWITCHING CHARACTERISTICS⁽¹⁾ (Over Operating Range)

Symbol	Parameter	-70		-85		Unit
		Min.	Max.	Min.	Max.	
t _{RC}	Read Cycle Time	70	—	85	—	ns
t _{AA}	Address Access Time	—	70	—	85	ns
t _{OHA}	Output Hold Time	10	—	10	—	ns
t _{ACE}	CE Access Time	—	70	—	85	ns
t _{DOE}	OE Access Time	—	35	—	40	ns
t _{HZOE⁽²⁾}	OE to High-Z Output	—	25	—	25	ns
t _{LZOE⁽²⁾}	OE to Low-Z Output	5	—	5	—	ns
t _{HZCE⁽²⁾}	CE to High-Z Output	0	25	0	25	ns
t _{LZCE⁽²⁾}	CE to Low-Z Output	10	—	10	—	ns
t _{BA}	LB, UB Access Time	—	70	—	85	ns
t _{HZB}	LB, UB to High-Z Output	0	25	0	25	ns
t _{LZB}	LB, UB to Low-Z Output	0	—	0	—	ns

Notes:

- Test conditions assume signal transition times of 5 ns or less, timing reference levels of 0.9V, input pulse levels of 0.4 to 1.4V and output loading specified in Figure 1.
- Tested with the load in Figure 2. Transition is measured ±500 mV from steady-state voltage. Not 100% tested.

AC WAVEFORMS

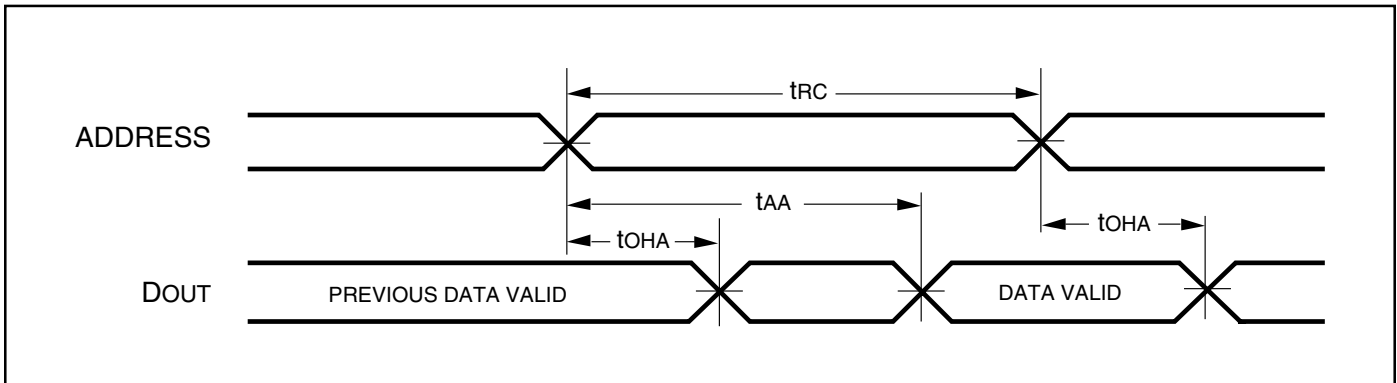
READ CYCLE NO. 1^(1,2) (Address Controlled) ($\overline{CE} = \overline{OE} = V_{IL}$, \overline{UB} or $\overline{LB} = V_{IL}$)

AC WAVEFORMS

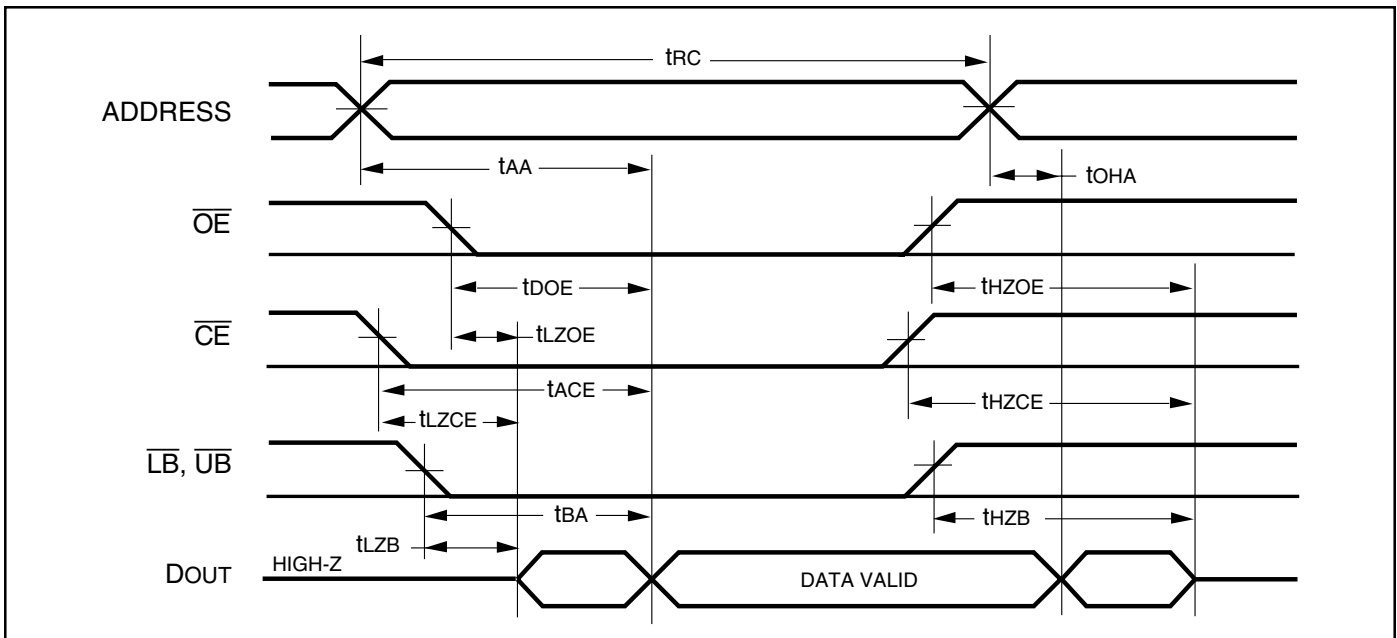
READ CYCLE NO. 2^(1,3) (\overline{CE} , \overline{OE} , AND $\overline{UB}/\overline{LB}$ Controlled)

Notes:

1. \overline{WE} is HIGH for a Read Cycle.
2. The device is continuously selected. \overline{OE} , \overline{CE} , \overline{UB} , or $\overline{LB} = V_{IL}$.
3. Address is valid prior to or coincident with \overline{CE} LOW transition.

WRITE CYCLE SWITCHING CHARACTERISTICS^(1,2) (Over Operating Range)

Symbol	Parameter	-70		-85		Unit
		Min.	Max.	Min.	Max.	
t _{WC}	Write Cycle Time	70	—	85	—	1ns
t _{SCE}	\overline{CE} to Write End	65	—	70	—	ns
t _{AW}	Address Setup Time to Write End	65	—	70	—	ns
t _{HA}	Address Hold from Write End	0	—	0	—	ns
t _{SA}	Address Setup Time	0	—	0	—	ns
t _{PWB}	\overline{LB} , \overline{UB} Valid to End of Write	60	—	70	—	ns
t _{PWE}	\overline{WE} Pulse Width	55	—	60	—	ns
t _{SD}	Data Setup to Write End	30	—	35	—	ns
t _{HD}	Data Hold from Write End	0	—	0	—	ns
t _{HZWE} ⁽³⁾	\overline{WE} LOW to High-Z Output	—	30	—	30	ns
t _{LZWE} ⁽³⁾	\overline{WE} HIGH to Low-Z Output	5	—	5	—	ns

Notes:

1. Test conditions assume signal transition times of 5 ns or less, timing reference levels of 0.9V, input pulse levels of 0.4V to 1.4V and output loading specified in Figure 1.
2. The internal write time is defined by the overlap of \overline{CE} LOW and \overline{UB} or \overline{LB} , and \overline{WE} LOW. All signals must be in valid states to initiate a Write, but any one can go inactive to terminate the Write. The Data Input Setup and Hold timing are referenced to the rising or falling edge of the signal that terminates the write.
3. Tested with the load in Figure 2. Transition is measured ± 500 mV from steady-state voltage. Not 100% tested.

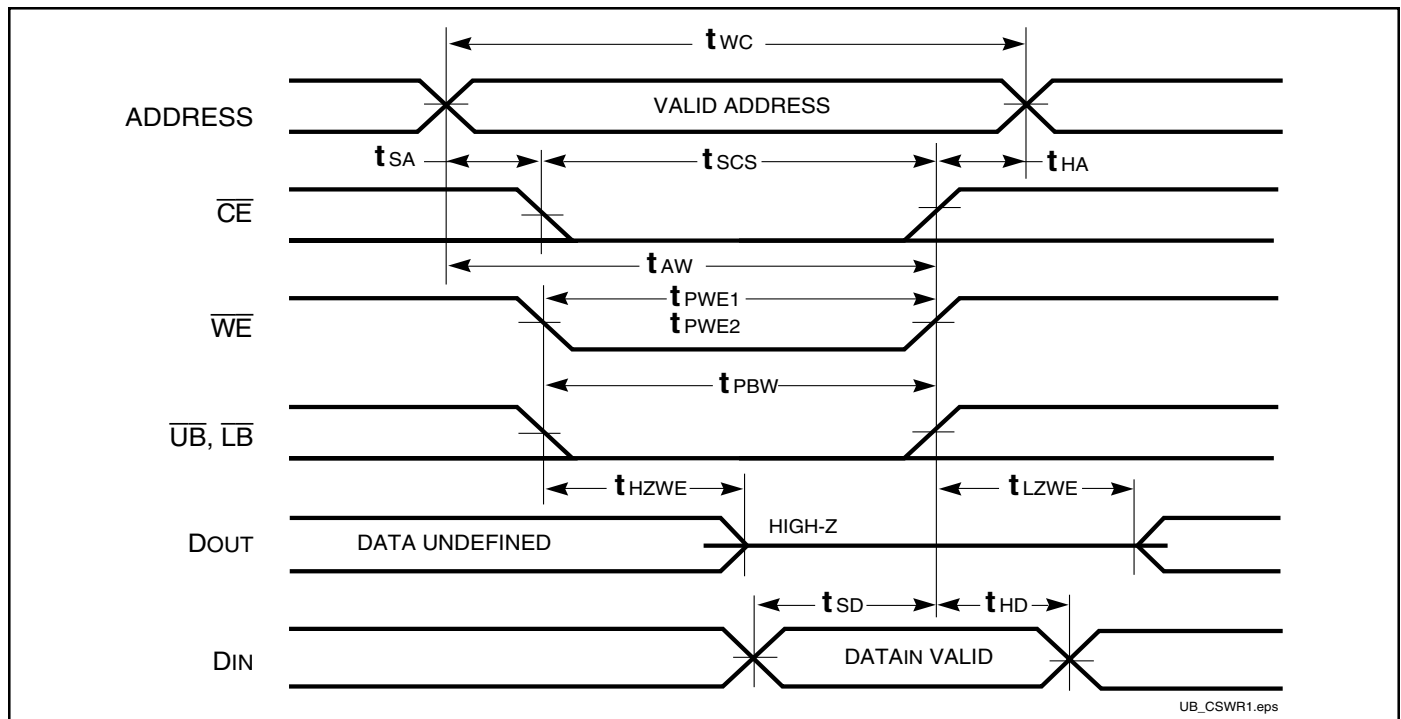
AC WAVEFORMS**WRITE CYCLE NO. 1^(1,2)** (\overline{CE} Controlled, \overline{OE} = HIGH or LOW)**Notes:**

1. WRITE is an internally generated signal asserted during an overlap of the LOW states on the \overline{CE} and \overline{WE} inputs and at least one of the \overline{LB} and \overline{UB} inputs being in the LOW state.
2. WRITE = (CE) [(LB) = (UB)] (WE).

WRITE CYCLE NO. 2 (\overline{WE} Controlled: \overline{OE} is HIGH During Write Cycle)

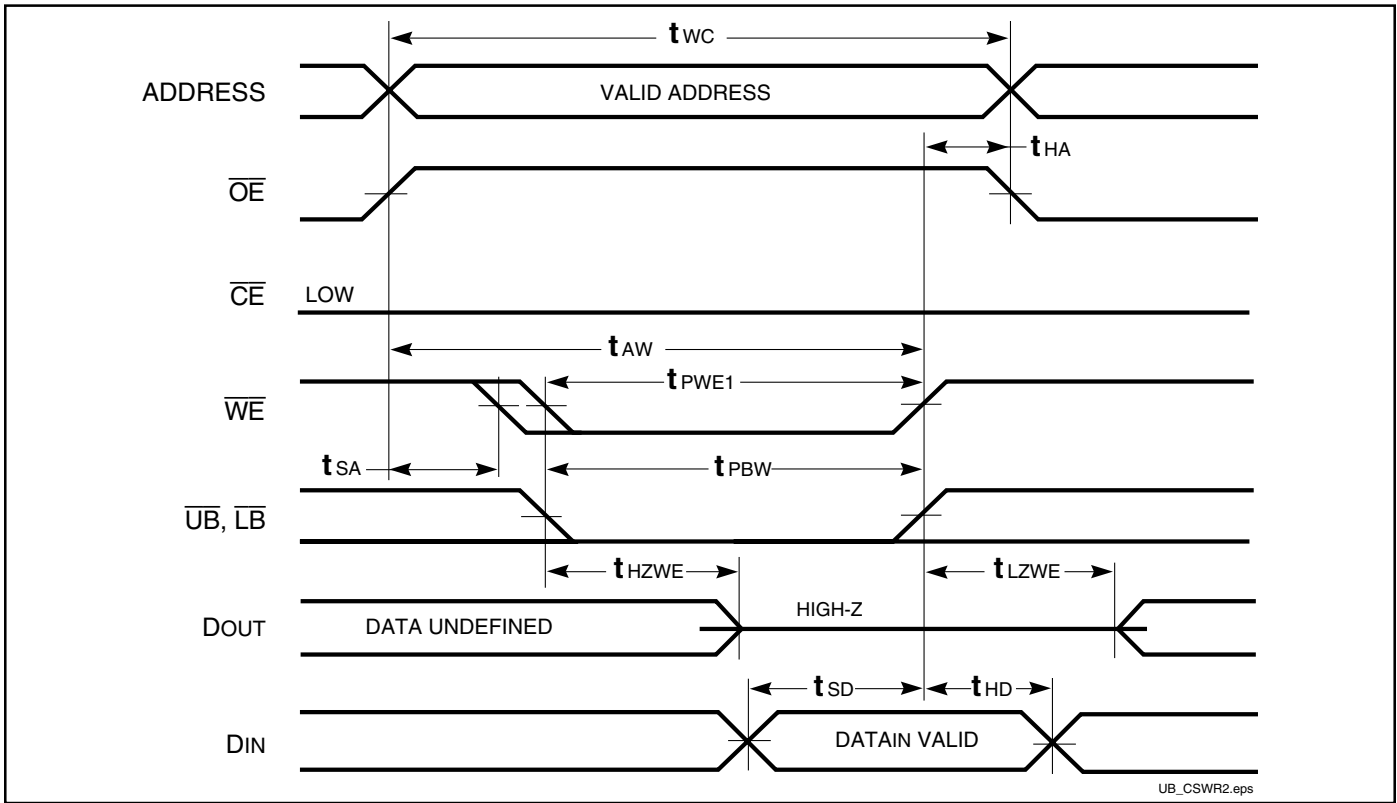

WRITE CYCLE NO. 3 (\overline{WE} Controlled: \overline{OE} is LOW During Write Cycle)

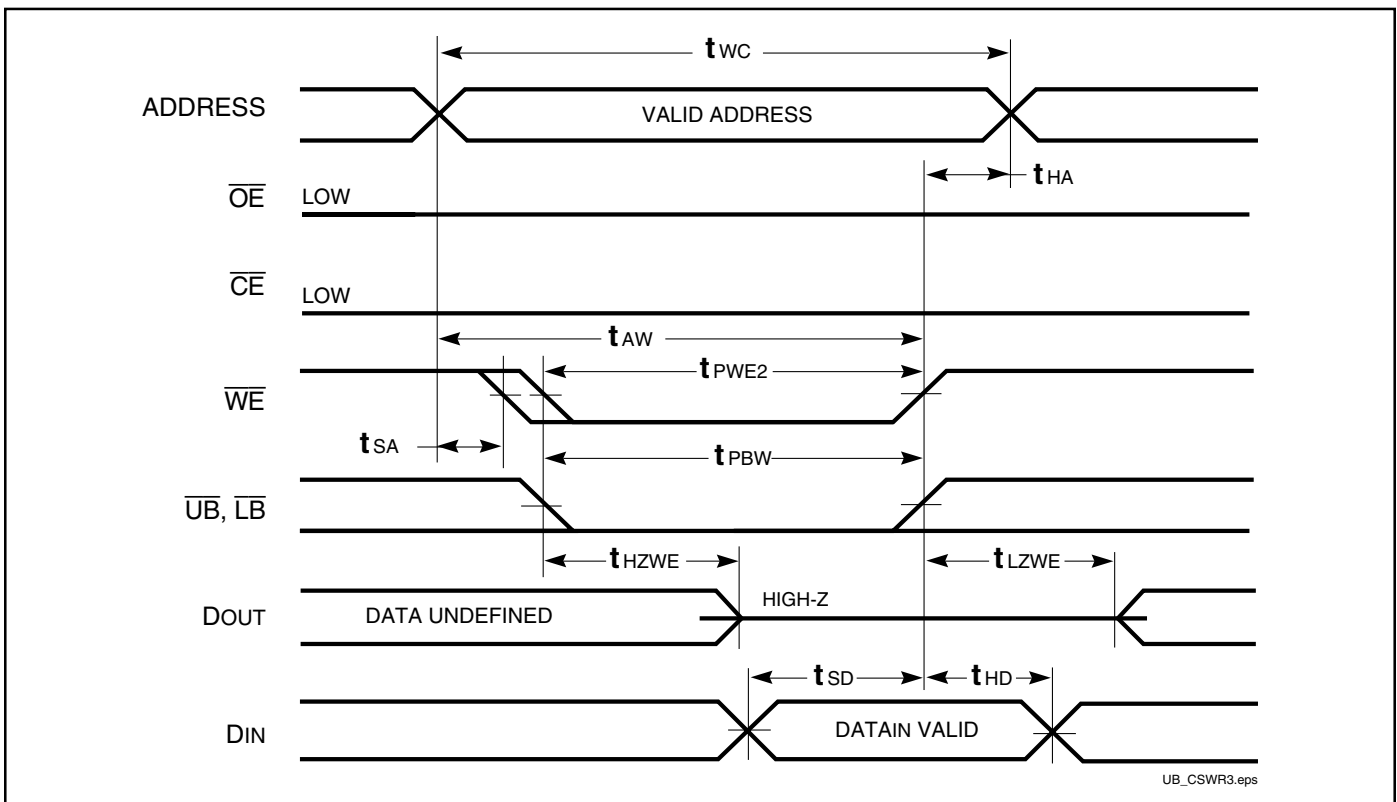

WRITE CYCLE NO. 4 ($\overline{UB}/\overline{LB}$ Controlled)

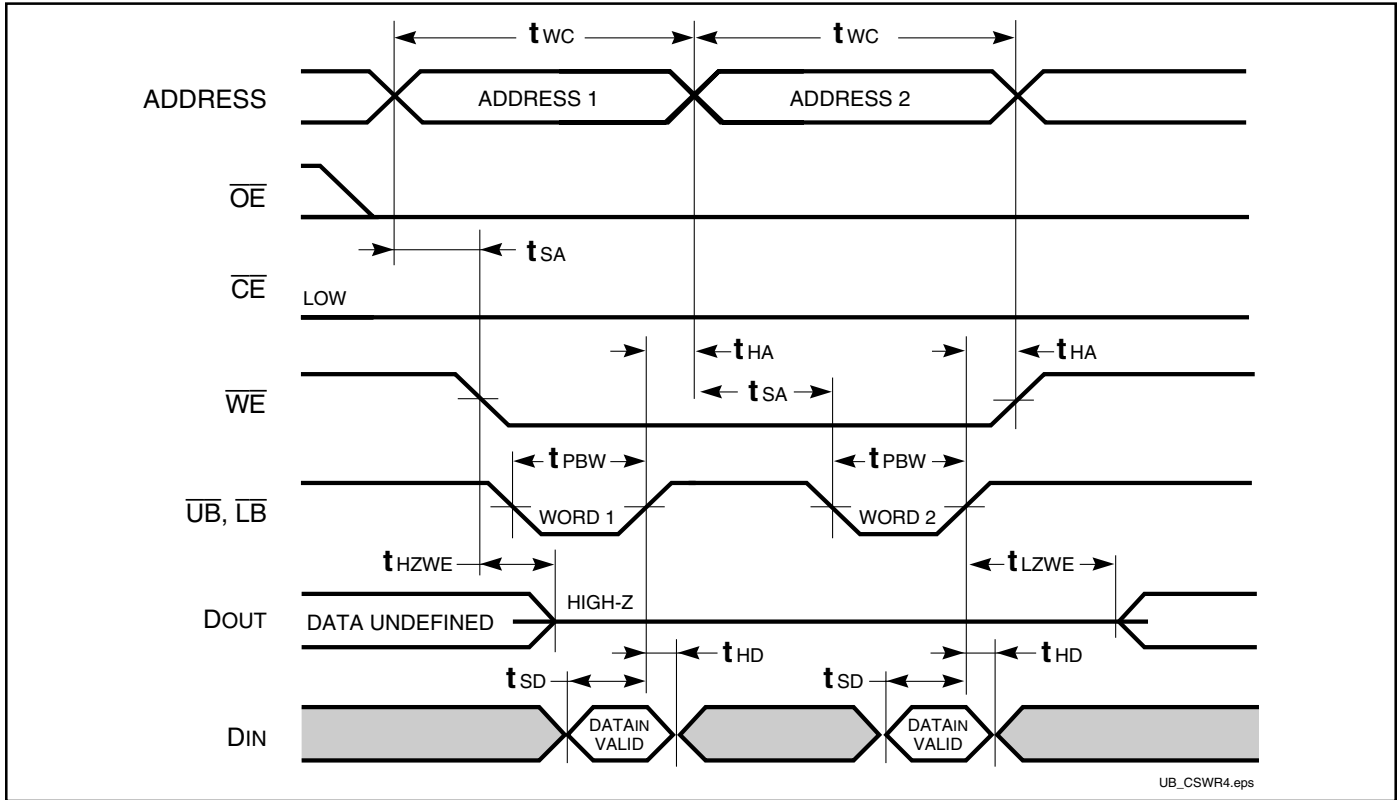

DATA RETENTION SWITCHING CHARACTERISTICS

Symbol	Parameter	Test Condition	Min.	Max.	Unit
V_{DR}	Vcc for Data Retention	See Data Retention Waveform	1.0	1.95	V
I_{DR}	Data Retention Current	$V_{cc} = 1.0V, \overline{CE} \geq V_{cc} - 0.2V$	—	10	μA
t_{SDR}	Data Retention Setup Time	See Data Retention Waveform	0	—	ns

DATA RETENTION WAVEFORM (\overline{CE} Controlled)

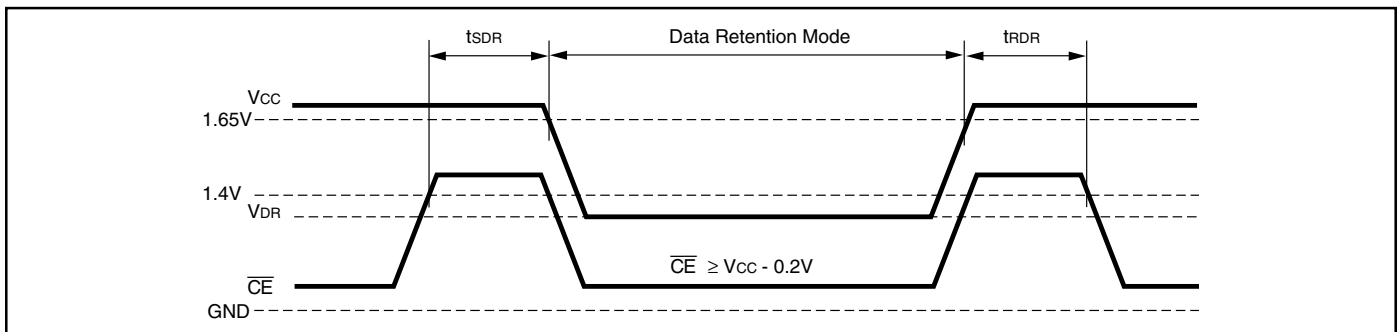

ORDERING INFORMATION**Commercial Range: 0°C to +70°C**

Speed (ns)	Order Part No.	Package
70	IS62VV25616LL-70T	TSOP (Type II)
	IS62VV25616LL-70M	MiniBGA (7.2mmx8.7mm)
85	IS62VV25616LL-85T	TSOP (Type II)
	IS62VV25616LL-85M	MiniBGA (7.2mmx8.7mm)

Industrial Range: -40°C to +85°C

Speed (ns)	Order Part No.	Package
70	IS62VV25616LL-70TI	TSOP (Type II)
	IS62VV25616LL-70MI	MiniBGA (7.2mmx8.7mm)
85	IS62VV25616LL-85TI	TSOP (Type II)
	IS62VV25616LL-85MI	MiniBGA (7.2mmx8.7mm)

ISSI®

Integrated Silicon Solution, Inc.

2231 Lawson Lane
 Santa Clara, CA 95054
 Tel: 1-800-379-4774
 Fax: (408) 588-0806
 E-mail: sales@issi.com
www.issi.com