

MARKETING SALES DRAWING

DIMENSIONS IN INCHES - DO NOT SCALE THIS DRAWING
DIMENSIONS IN METRIC - []

This drawing is the property of Tusonix, Inc., and may not be used, reproduced, published or disclosed to others without expressed authorization by Tusonix Inc.

Electrical Testing
per Tusonix standard
test plans and Mil-Std-202
Test Methods.

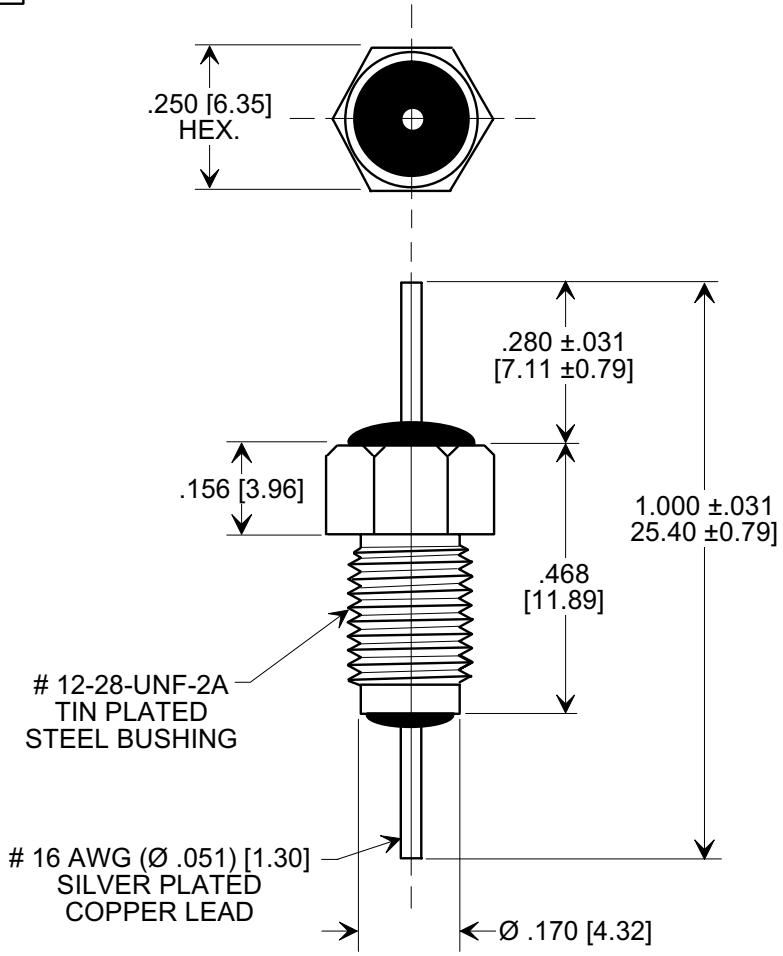
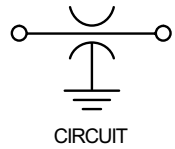
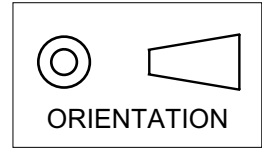

NOTES:

- SUPPLIED WITH SILVER PLATED HEX NUT AND INTERNAL TOOTH LOCK WASHER.
- TUSONIX STANDARD PART
 NUMBER: 2499-522-X5W0-103Z.
 TUSONIX RoHS COMPLIANT PART
 NUMBER: 2499-522-X5W0-103Z LF.
 CUSTOMER MUST SPECIFY STANDARD OR RoHS PART NUMBER WHEN ORDERING.
- MOUNTING HARDWARE: TIN PLATED LOCK WASHER & BUSHING.
- PART MARKING: TRADEMARK, CAPACITANCE CODE AND TOLERANCE CODE STAMPED ON BUSHING HEX FLATS:
 STANDARD PART: BLACK MARKING.
 RoHS COMPLIANT PART: GREEN MARKING.

ORDERING INFORMATION

TUSONIX STYLE:	2499-522
CAPACITANCE VALUE:	10,000 pF
CAPACITANCE TOL.:	+80, -20%
TEMP. CHARACTERISTICS:	X5W
RATING:	1000 VDC @ 85°C
CURRENT (A):	20
OPERATING RANGE:	-55 TO +85°C
I.R. MIN. @ 100 (VDC):	10 G Ω
DWV (VDC):	1750

X-2015 Rev-0

REVISION RECORD Original Release C.O. 19980623-2-02 ADDED CURRENT, IR, DWV & METRIC. ADDED & REVISED NOTES. S.M. 07-31-06 20060712-6-17 CORRECT TYPOS. S.M. 11-30-07 20071129-2-01	--TOLERANCES-- Unless Otherwise Specified	Title BUSHING STYLE FEED-THRU CAPACITOR	
	DECIMAL ± .015 [0.38]		
	ANGLES ±	Drawn S.M. 06-26-98	Scale 3 X
	TUSONIX TUCSON, ARIZONA	Approved S.C. 06-26-98	A