

FEATURES

- EIA SIZES A (1210), B (1812), C (1008) AND D (0805)
- EXCELLENT HIGH Q AND HIGH SRF CHARACTERISTICS
- BOTH FLOW AND REFLOW SOLDERING APPLICABLE
- HIGH INDUCTANCE AVAILABLE IN SMALL SIZE
- EMBOSSED PLASTIC TAPE PACKAGE FOR AUTOMATIC PICK-PLACE

**RoHS
Compliant**
includes all homogeneous materials

*See Part Number System for Details

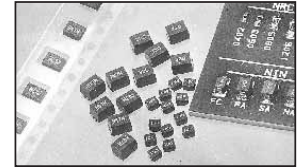

AVAILABLE TYPE AND RANGE

EIA Size	Size Code	Size (L x W x H mm)	NIC Type	Inductance Range	Style
0805	D	2.0 x 1.25 x 1.25	NIN-ND	10nH ~ 1.0μH	Standard
1008	C	2.5 x 2.0 x 1.6	NIN-FC	0.22 ~ 100μH	Standard
			NIN-NC	10nH ~ 0.82μH	High Frequency
			NIN-PC	1.0 ~ 33μH	High Current
			NIN-FA	0.22 ~ 220μH	Standard
1210	A	3.2 x 2.5 x 2.2	NIN-NA	47nH ~ 8.2μH	High Frequency
			NIN-PA	1.0 ~ 330μH	High Current
			NIN-FB	0.1 ~ 1000μH	Standard
1812	B	4.5 x 3.2 x 3.2	NIN-FB	0.1 ~ 1000μH	Standard

SPECIFICATIONS

Specifications	Case Size			
	0805	1008	1210	1812
Inductance Range	10nH ~ 1.0μH	10nH ~ 100μH	47nH ~ 330μH	0.10μH ~ 1000μH
Inductance Tolerance	±10% (K), ±5% (J)	±20% (M), ±10% (K), ±5% (J)		±10% (K), ±5% (J)
Operating Temperature Range	-25°C ~ +85°C (at 100% of rated voltage)			
Insulation Resistance	1,000 MegOhm Min. (@ 100Vdc, Termination to Case)			
Withstanding Voltage	250Vdc for 1 minute (Termination to Case)			
Q Factor, Self Resonant Frequency, DC Resistance, Rated DC Current and Inductance Tolerance	See Individual Product Listings			

ENVIRONMENTAL CHARACTERISTICS

Test	Specification	Test Method & Condition
Solderability	90% Min. Coverage	After 3 Sec. Dip in +230°C Solder Pot (Post Flux)
Humidity	(1) No Evidence of Damage (2) Inductance Shall Be Within ±5% of Initial Value (3) Q Factor Shall Be Within ±10% of Initial Value	After 500 Hrs at +60°C and 90~95% RH
Soldering Effect		After 5 Sec. at +260°C (5 min. 120°C Pre-Heat)
Low Frequency Vibration		After 2 Hrs per Axis, 10 ~ 55Hz, 1.5mm Amplitude
Thermal Shock		After 100 Cycles (-40°C ~ +85°C) 30 Min. Each
Low Temperature Storage		After 500 Hrs at -40°C
High Temperature Load Life	(1) No Evidence of Damage (2) Inductance Shall Be Within ±10% of Initial Value (3) Q Factor Shall Be Within ±10% of Initial Value	After 500 Hrs. at +85°C with Rated DC Current
Humidity Load Life		After 500 Hrs at +60°C with 90~95% RH at Rated DC Current

DIMENSIONS (mm)

SIZE A, C and D

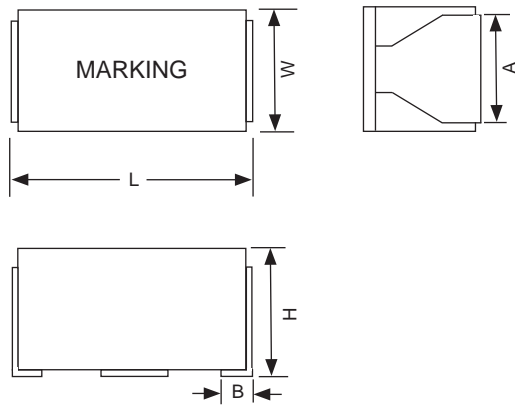

SIZE B

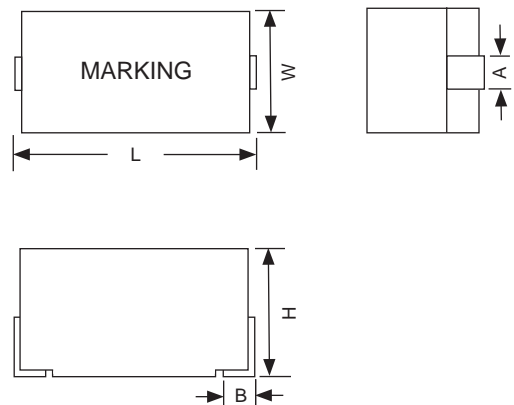

EIA Size	Size Code	Dim. L	Dim. W	Dim. H	Dim. A	Dim. B
0805	D	2.0 ^{+0.3/-0.2}	1.25 ± 0.3	1.25 ± 0.3	1.0 ± 0.1	0.4 ± 0.2
1008	C	2.5 ^{+0.3/-0.2}	2.0 ± 0.2	1.6 ± 0.2	1.2 ± 0.1	0.4 ± 0.2
1210	A	3.2 ± 0.3	2.5 ± 0.2	2.2 ± 0.2	1.9 ± 0.1	0.6 ± 0.2
1812	B	4.5 ± 0.3	3.2 ± 0.2	3.2 ± 0.2	1.1 ± 0.2	1.2 ± 0.3

PART MARKING

Inductance Tolerance	Marking for Tolerance	Example
±20%	M	2R2M
±10%	No Identification	470
±5%	J	270J

(1) 3 digits system in μH

(2) R indicates decimal point in μH Ex: 2R7 = 2.7 μH
Ex: R18 = .18 μH = 180nH

(3) N indicates nanohenries (0.001 μH), Ex: 10N = 0.01 μH = 10nH

Applicable Guidelines:

1. Recommended soldering conditions :

Flow (wave): 250°C for 5 sec. max. (preheating of 120°C for 5 minutes.)

Reflow: 250°C for 10 sec. max., total time above 230°C is 40 sec. max. (preheating 150°C ~ 180°C/120 sec. max.)

2. Avoid placing inductor over any metal pattern on the PCB, which may create mutual inductance problems.

3. For mounting, it is suggested to secure chip inductor by means of epoxy adhesive curable by ultraviolet.

4. Ultrasonic cleaning is not recommended. If it is necessary, the cleaning conditions must be examined so as not to create mechanical damage by unexpected resonant vibration. Please contact our engineering department.

5. An excessive mechanical force may effect the electrical and magnetic properties of chip inductors. Make sure not to use any stress greater than 2Kg when component is placed.

PART NUMBER SYSTEM

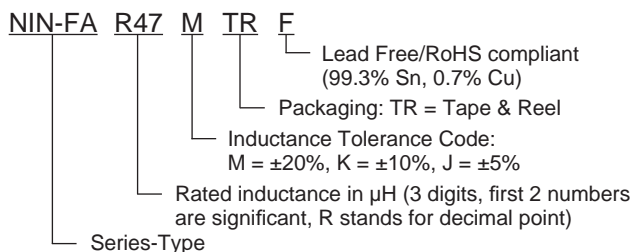

NIN-ND SERIES

D SIZE (0805)

STANDARD TYPE

NIC P/N	'L' Inductance (nH)	Tolerance		'Q' Factor (min.)	L & Q Test Frequency	SRF MHz (min.)	DC Resistance (ohms) Max.	Rated DC Current (mA) Max.
		(std)	(opt)					
NIN-ND10NKTRF	10	±10% (K)	-	10	100 MHz	3300	0.18	540
NIN-ND12NKTRF	12	±10% (K)	-	10	100 MHz	3300	0.24	535
NIN-ND15NKTRF	15	±10% (K)	-	12	100 MHz	3000	0.24	520
NIN-ND18NKTRF	18	±10% (K)	-	12	100 MHz	3000	0.29	480
NIN-ND22NKTRF	22	±10% (K)	-	12	100 MHz	2600	0.29	465
NIN-ND27NKTRF	27	±10% (K)	-	15	100 MHz	2500	0.34	455
NIN-ND33NxTRF	33	±10% (K)	±5% (J)	15	100 MHz	2050	0.39	395
NIN-ND39NxTRF	39	±10% (K)	±5% (J)	15	100 MHz	2000	0.41	390
NIN-ND47NxTRF	47	±10% (K)	±5% (J)	15	100 MHz	1650	0.46	385
NIN-ND56NxTRF	56	±10% (K)	±5% (J)	15	100 MHz	1550	0.51	360
NIN-ND68NxTRF	68	±10% (K)	±5% (J)	15	100 MHz	1450	0.57	340
NIN-ND82NxTRF	82	±10% (K)	±5% (J)	15	100 MHz	1100	0.63	330
NIN-NDR10xTRF	100	±10% (K)	±5% (J)	8	25.2 MHz	800	0.86	285
NIN-NDR12xTRF	120	±10% (K)	±5% (J)	8	25.2 MHz	600	0.99	275
NIN-NDR15xTRF	150	±10% (K)	±5% (J)	10	25.2 MHz	600	1.47	230
NIN-NDR18xTRF	180	±10% (K)	±5% (J)	10	25.2 MHz	600	1.61	195
NIN-NDR22xTRF	220	±10% (K)	±5% (J)	10	25.2 MHz	500	1.84	170
NIN-NDR27xTRF	270	±10% (K)	±5% (J)	10	25.2 MHz	300	1.95	165
NIN-NDR33xTRF	330	±10% (K)	±5% (J)	10	25.2 MHz	200	2.16	160
NIN-NDR39xTRF	390	±10% (K)	±5% (J)	10	25.2 MHz	150	2.37	150
NIN-NDR47xTRF	470	±10% (K)	±5% (J)	10	25.2 MHz	150	2.56	145
NIN-NDR56xTRF	560	±10% (K)	±5% (J)	10	25.2 MHz	100	2.69	140
NIN-NDR68xTRF	680	±10% (K)	±5% (J)	10	25.2 MHz	100	3.02	130
NIN-NDR82xTRF	820	±10% (K)	±5% (J)	10	25.2 MHz	80	3.38	125
NIN-ND1R0xTRF	1,000	±10% (K)	±5% (J)	8	7.96 MHz	80	3.88	120

For Quality Factor (Q) and Inductance (L) over Frequency curves see www.RFpassives.com

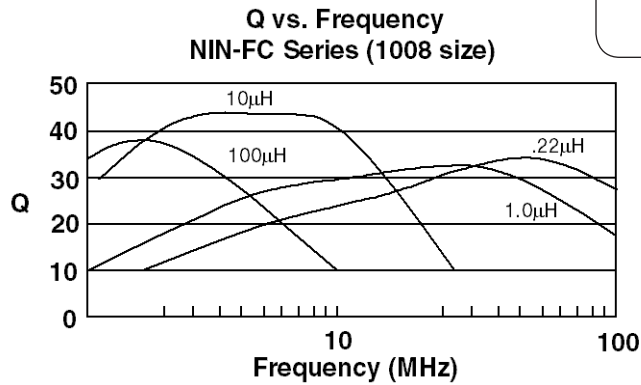

NIN-FC SERIES

C SIZE (1008)

STANDARD TYPE

NIC P/N	'L' Inductance (µH)	Tolerance		'Q' Factor (min.)	L & Q Test Frequency	SRF MHz (min.)	DC Resistance (ohms) Max.	Rated DC Current (mA) Max.
		(std)	(opt)					
NIN-FCR22xTRF	0.22	±20% (M)	±10% (K)	25	25.2 MHz	230	0.70	190
NIN-FCR27xTRF	0.27	±20% (M)	±10% (K)	25	25.2 MHz	210	0.75	180
NIN-FCR33xTRF	0.33	±20% (M)	±10% (K)	25	25.2 MHz	190	0.85	170
NIN-FCR39xTRF	0.39	±20% (M)	±10% (K)	25	25.2 MHz	175	0.95	160
NIN-FCR47xTRF	0.47	±20% (M)	±10% (K)	25	25.2 MHz	160	1.00	155
NIN-FCR56xTRF	0.56	±20% (M)	±10% (K)	25	25.2 MHz	150	1.10	150
NIN-FCR68xTRF	0.68	±20% (M)	±10% (K)	25	25.2 MHz	135	1.25	140
NIN-FCR82xTRF	0.82	±20% (M)	±10% (K)	25	25.2 MHz	125	1.40	130
NIN-FC1R0xTRF	1.0	±10% (K)	±5% (J)	25	7.96 MHz	115	0.65	195
NIN-FC1R2xTRF	1.2	±10% (K)	±5% (J)	25	7.96 MHz	100	0.75	180
NIN-FC1R5xTRF	1.5	±10% (K)	±5% (J)	25	7.96 MHz	90	0.85	170
NIN-FC1R8xTRF	1.8	±10% (K)	±5% (J)	25	7.96 MHz	85	0.95	160
NIN-FC2R2xTRF	2.2	±10% (K)	±5% (J)	25	7.96 MHz	80	1.05	155
NIN-FC2R7xTRF	2.7	±10% (K)	±5% (J)	25	7.96 MHz	75	1.20	145
NIN-FC3R3xTRF	3.3	±10% (K)	±5% (J)	25	7.96 MHz	65	1.30	135
NIN-FC3R9xTRF	3.9	±10% (K)	±5% (J)	25	7.96 MHz	60	1.40	130
NIN-FC4R7xTRF	4.7	±10% (K)	±5% (J)	25	7.96 MHz	55	1.55	125
NIN-FC5R6xTRF	5.8	±10% (K)	±5% (J)	25	7.96 MHz	50	1.75	120
NIN-FC6R8xTRF	6.8	±10% (K)	±5% (J)	25	7.96 MHz	45	1.95	115
NIN-FC8R2xTRF	8.2	±10% (K)	±5% (J)	25	7.96 MHz	40	2.20	105
NIN-FC100xTRF	10	±10% (K)	±5% (J)	25	2.52 MHz	32	3.05	80
NIN-FC120xTRF	12	±10% (K)	±5% (J)	25	2.52 MHz	30	3.80	75
NIN-FC150xTRF	15	±10% (K)	±5% (J)	25	2.52 MHz	28	4.40	70
NIN-FC180xTRF	18	±10% (K)	±5% (J)	25	2.52 MHz	25	5.00	65
NIN-FC220xTRF	22	±10% (K)	±5% (J)	25	2.52 MHz	22	5.80	60
NIN-FC270xTRF	27	±10% (K)	±5% (J)	25	2.52 MHz	21	6.30	115
NIN-FC330xTRF	33	±10% (K)	±5% (J)	25	2.52 MHz	20	7.10	110
NIN-FC390xTRF	39	±10% (K)	±5% (J)	25	2.52 MHz	18	9.50	90
NIN-FC470xTRF	47	±10% (K)	±5% (J)	25	2.52 MHz	17	11.0	80
NIN-FC560xTRF	56	±10% (K)	±5% (J)	25	2.52 MHz	16	12.1	75
NIN-FC680xTRF	68	±10% (K)	±5% (J)	25	2.52 MHz	15	16.6	70
NIN-FC820xTRF	82	±10% (K)	±5% (J)	25	2.52 MHz	13	19.0	65
NIN-FC101xTRF	100	±10% (K)	±5% (J)	25	0.796 MHz	12	21.0	60

For Quality Factor (Q) and Inductance (L) over Frequency curves see www.RFpassives.com

Q vs Frequency
NIN-NC Series (1008 size)
High Frequency Type

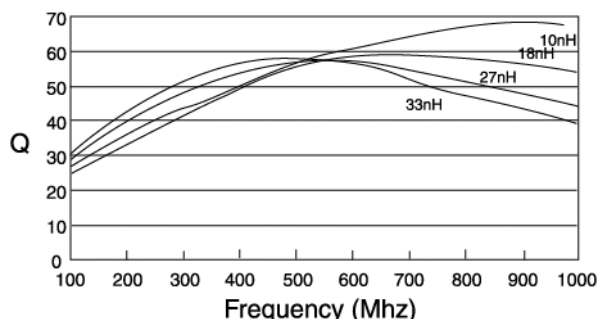

NIN-NC SERIES C SIZE (1008) HIGH FREQUENCY TYPE

NIC P/N	'L' Inductance (nH)	Tolerance		'Q' Factor (min.)	L & Q Test Frequency	SRF MHz (min.)	DC Resistance (ohms) Max.	Rated DC Current (mA) Max.
		(std)	(opt)					
NIN-NC10NKTRF	10	±10% (K)	---	10	100 MHz	2500	0.32	280
NIN-NC12NKTRF	12	±10% (K)	---	10	100 MHz	2200	0.34	270
NIN-NC15NKTRF	15	±10% (K)	---	10	100 MHz	1800	0.38	255
NIN-NC18NKTRF	18	±10% (K)	---	10	100 MHz	1550	0.40	250
NIN-NC22NKTRF	22	±10% (K)	---	15	100 MHz	1350	0.43	240
NIN-NC27NKTRF	27	±10% (K)	---	15	100 MHz	1150	0.47	230
NIN-NC33NxTRF	33	±10% (K)	±5% (J)	15	100 MHz	1000	0.51	220
NIN-NC39NxTRF	39	±10% (K)	±5% (J)	15	100 MHz	890	0.55	215
NIN-NC47NxTRF	47	±10% (K)	±5% (J)	15	100 MHz	770	0.59	205
NIN-NC56NxTRF	56	±10% (K)	±5% (J)	15	100 MHz	670	0.63	200
NIN-NC68NxTRF	68	±10% (K)	±5% (J)	15	100 MHz	590	0.68	190
NIN-NC82NxTRF	82	±10% (K)	±5% (J)	15	100 MHz	520	0.73	185
NIN-NCR10xTRF	100	±10% (K)	±5% (J)	10	25.2 MHz	460	0.80	175
NIN-NCR12xTRF	120	±10% (K)	±5% (J)	10	25.2 MHz	400	0.87	170
NIN-NCR15xTRF	150	±10% (K)	±5% (J)	10	25.2 MHz	340	0.98	160
NIN-NCR18xTRF	180	±10% (K)	±5% (J)	10	25.2 MHz	300	1.05	155
NIN-NCR22xTRF	220	±10% (K)	±5% (J)	10	25.2 MHz	260	1.15	145
NIN-NCR27xTRF	270	±10% (K)	±5% (J)	10	25.2 MHz	230	1.25	140
NIN-NCR33xTRF	330	±10% (K)	±5% (J)	10	25.2 MHz	200	1.37	135
NIN-NCR39xTRF	390	±10% (K)	±5% (J)	10	25.2 MHz	180	1.47	130
NIN-NCR47xTRF	470	±10% (K)	±5% (J)	10	25.2 MHz	160	1.58	125
NIN-NCR56xTRF	560	±10% (K)	±5% (J)	10	25.2 MHz	145	1.70	120
NIN-NCR68xTRF	680	±10% (K)	±5% (J)	10	25.2 MHz	130	1.85	110
NIN-NCR82xTRF	820	±10% (K)	±5% (J)	10	25.2 MHz	100	2.10	100

For Quality Factor (Q) and Inductance (L)
over Frequency curves
see www.RFpassives.com

NIN-PC SERIES C SIZE (1008) HIGH CURRENT TYPE

NIC P/N	'L' Inductance (nH)	Tolerance		'Q' Factor (min.)	L & Q Test Frequency	SRF MHz (min.)	DC Resistance (ohms) Max.	Rated DC Current (mA) Max.
		(std)	(opt)					
NIN-PC1R0MTRF	1.0	±20% (M)	---	10	7.96 MHz	95	0.45	475
NIN-PC1R5MTRF	1.5	±20% (M)	---	10	7.96 MHz	85	0.55	435
NIN-PC2R2MTRF	2.2	±20% (M)	---	10	7.96 MHz	65	0.65	390
NIN-PC3R3MTRF	3.3	±20% (M)	---	8	7.96 MHz	55	0.85	340
NIN-PC4R7MTRF	4.7	±20% (M)	---	8	7.96 MHz	43	1.20	285
NIN-PC6R8MTRF	6.8	±20% (M)	---	8	7.96 MHz	39	1.30	275
NIN-PC100KTRF	10	±10% (K)	---	20	2.52 MHz	32	2.20	210
NIN-PC120KTRF	12	±10% (K)	---	20	2.52 MHz	25	2.70	195
NIN-PC150KTRF	15	±10% (K)	---	20	2.52 MHz	21	3.20	175
NIN-PC220KTRF	22	±10% (K)	---	20	2.52 MHz	18	4.00	160
NIN-PC330KTRF	33	±10% (K)	---	20	2.52 MHz	16	6.50	120

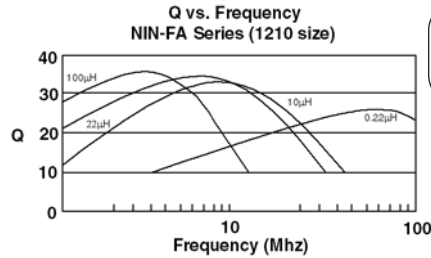

For Quality Factor (Q) and Inductance (L) over Frequency curves see www.RFpassives.com

NIN-FA SERIES A SIZE (1210) STANDARD TYPE

NIC P/N	'L' Inductance (µH)	Tolerance		'Q' Factor (min.)	L & Q Test Frequency	SRF MHz (min.)	DC Resistance (ohms) Max.	Rated DC Current (mA) Max.
		(std)	(opt)					
NIN-FAR22xTRF	0.22	±20% (M)	±10% (K)	25	25.2 MHz	230	0.29	360
NIN-FAR27xTRF	0.27	±20% (M)	±10% (K)	25	25.2 MHz	210	0.32	345
NIN-FAR33xTRF	0.33	±20% (M)	±10% (K)	25	25.2 MHz	190	0.35	330
NIN-FAR39xTRF	0.39	±20% (M)	±10% (K)	25	25.2 MHz	175	0.39	305
NIN-FAR47xTRF	0.47	±20% (M)	±10% (K)	25	25.2 MHz	160	0.44	290
NIN-FAR56xTRF	0.56	±20% (M)	±10% (K)	25	25.2 MHz	150	0.49	275
NIN-FAR68xTRF	0.68	±20% (M)	±10% (K)	25	25.2 MHz	135	0.55	260
NIN-FAR82xTRF	0.82	±20% (M)	±10% (K)	25	25.2 MHz	125	0.61	245
NIN-FA1R0xTRF	1.0	±10% (K)	±5% (J)	30	7.96 MHz	115	0.69	230
NIN-FA1R2xTRF	1.2	±10% (K)	±5% (J)	30	7.96 MHz	100	0.75	215
NIN-FA1R5xTRF	1.5	±10% (K)	±5% (J)	30	7.96 MHz	90	0.75	210
NIN-FA1R8xTRF	1.8	±10% (K)	±5% (J)	30	7.96 MHz	85	0.82	200
NIN-FA2R2xTRF	2.2	±10% (K)	±5% (J)	30	7.96 MHz	80	0.95	190
NIN-FA2R7xTRF	2.7	±10% (K)	±5% (J)	30	7.96 MHz	75	1.10	180
NIN-FA3R3xTRF	3.3	±10% (K)	±5% (J)	30	7.96 MHz	65	1.20	180
NIN-FA3R9xTRF	3.9	±10% (K)	±5% (J)	30	7.96 MHz	60	1.30	175
NIN-FA4R7xTRF	4.7	±10% (K)	±5% (J)	30	7.96 MHz	55	1.50	165
NIN-FA5R6TRF	5.6	±10% (K)	±5% (J)	30	7.96 MHz	50	1.60	160
NIN-FA6R8xTRF	6.8	±10% (K)	±5% (J)	30	7.96 MHz	45	1.80	150
NIN-FA8R2xTRF	8.2	±10% (K)	±5% (J)	30	7.96 MHz	40	2.00	140
NIN-FA100xTRF	10	±10% (K)	±5% (J)	30	2.52 MHz	36	2.10	140
NIN-FA120xTRF	12	±10% (K)	±5% (J)	30	2.52 MHz	33	2.50	125
NIN-FA150xTRF	15	±10% (K)	±5% (J)	30	2.52 MHz	30	2.80	120
NIN-FA180xTRF	18	±10% (K)	±5% (J)	30	2.52 MHz	27	3.30	110
NIN-FA220xTRF	22	±10% (K)	±5% (J)	30	2.52 MHz	25	3.70	105
NIN-FA270xTRF	27	±10% (K)	±5% (J)	30	2.52 MHz	22	5.00	90
NIN-FA330xTRF	33	±10% (K)	±5% (J)	30	2.52 MHz	20	5.60	85
NIN-FA390xTRF	39	±10% (K)	±5% (J)	30	2.52 MHz	20	6.40	80
NIN-FA470xTRF	47	±10% (K)	±5% (J)	30	2.52 MHz	15	7.00	75
NIN-FA560xTRF	56	±10% (K)	±5% (J)	30	2.52 MHz	15	8.00	70
NIN-FA680xTRF	68	±10% (K)	±5% (J)	30	2.52 MHz	15	9.00	65
NIN-FA820xTRF	82	±10% (K)	±5% (J)	30	2.52 MHz	11	10.0	60
NIN-FA101xTRF	100	±10% (K)	±5% (J)	20	0.796 MHz	10	10.0	60
NIN-FA121xTRF	120	±10% (K)	±5% (J)	20	0.796 MHz	10	11.0	55
NIN-FA151xTRF	150	±10% (K)	±5% (J)	20	0.796 MHz	8	15.0	50
NIN-FA181xTRF	180	±10% (K)	±5% (J)	20	0.796 MHz	7	17.0	50
NIN-FA221xTRF	220	±10% (K)	±5% (J)	20	0.796 MHz	7	21.0	45

Q vs Frequency
NIN-NA Series (1210 Size)

For Quality Factor (Q) and Inductance (L) over Frequency curves see www.RFpassives.com

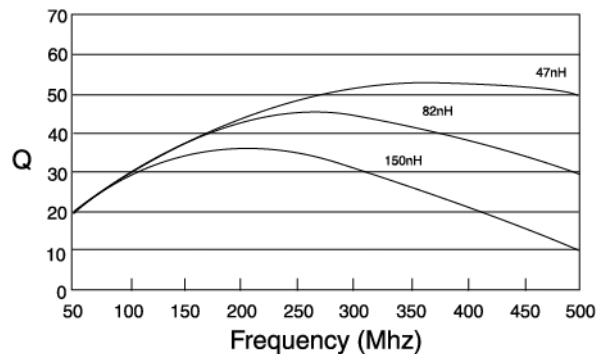

NIN-NA SERIES A SIZE (1210) HIGH FREQUENCY

NIC P/N	'L' Inductance (μH)	Tolerance		'Q' Factor (min.)	L & Q Test Frequency	SRF MHz (min.)	DC Resistance (ohms) Max.	Rated DC Current (mA) Max.
		(std)	(opt)					
NIN-NA47NMTRF	0.047	±20% (M)	---	10	100 MHz	680	0.20	450
NIN-NA56NMTRF	0.056	±20% (M)	---	10	100 MHz	600	0.22	420
NIN-NA68NMTRF	0.068	±20% (M)	---	10	100 MHz	540	0.25	400
NIN-NA82NMTRF	0.082	±20% (M)	---	10	100 MHz	500	0.27	380
NIN-NAR10MTRF	0.10	±20% (M)	---	10	100 MHz	450	0.30	360
NIN-NAR12MTRF	0.12	±20% (M)	---	10	25.2 MHz	400	0.67	240
NIN-NAR15MTRF	0.15	±20% (M)	---	10	25.2 MHz	350	0.72	230
NIN-NAR18MTRF	0.18	±20% (M)	---	10	25.2 MHz	320	0.81	220
NIN-NAR22KTRF	0.22	±10% (K)	---	10	25.2 MHz	280	0.90	210
NIN-NAR27KTRF	0.27	±10% (K)	---	10	25.2 MHz	250	1.00	200
NIN-NAR33KTRF	0.33	±10% (K)	---	10	25.2 MHz	220	1.10	190
NIN-NAR39KTRF	0.39	±10% (K)	---	10	25.2 MHz	200	1.20	180
NIN-NAR47KTRF	0.47	±10% (K)	---	10	25.2 MHz	180	1.40	175
NIN-NAR56KTRF	0.56	±10% (K)	---	10	25.2 MHz	160	1.50	170
NIN-NAR68KTRF	0.68	±10% (K)	---	10	25.2 MHz	150	1.70	155
NIN-NAR82KTRF	0.82	±10% (K)	---	10	25.2 MHz	135	1.90	145
NIN-NA1R0JTRF	1.0	±5% (J)	---	13	7.96 MHz	120	2.10	125
NIN-NA1R2JTRF	1.2	±5% (J)	---	13	7.96 MHz	110	2.20	120
NIN-NA1R5JTRF	1.5	±5% (J)	---	13	7.96 MHz	95	2.70	115
NIN-NA1R8JTRF	1.8	±5% (J)	---	13	7.96 MHz	85	3.00	110
NIN-NA2R2JTRF	2.2	±5% (J)	---	13	7.96 MHz	80	3.20	110
NIN-NA2R7JTRF	2.7	±5% (J)	---	13	7.96 MHz	70	3.60	105
NIN-NA3R3JTRF	3.3	±5% (J)	---	13	7.96 MHz	62	4.20	100
NIN-NA3R9JTRF	3.9	±5% (J)	---	13	7.96 MHz	57	4.40	95
NIN-NA4R7JTRF	4.7	±5% (J)	---	13	7.96 MHz	52	7.70	70
NIN-NA5R6JTRF	5.6	±5% (J)	---	13	7.96 MHz	46	8.70	65
NIN-NA6R8JTRF	6.8	±5% (J)	---	13	7.96 MHz	42	10.0	60
NIN-NA8R2JTRF	8.2	±5% (J)	---	13	7.96 MHz	38	11.0	60

For Quality Factor (Q) and Inductance (L)
over Frequency curves
see www.RFpassives.com

NIN-PA SERIES A SIZE (1210) HIGH CURRENT TYPE

NIC P/N	'L' Inductance (μ H)	Tolerance		'Q' Factor (min.)	L & Q Test Frequency	SRF MHz (min.)	DC Resistance (ohms) Max.	Rated DC Current (mA) Max.
		(std)	(opt)					
NIN-PA1R0MTRF	1.0	$\pm 20\%$ (M)	---	7	7.96 MHz	150	0.15	600
NIN-PA1R5MTRF	1.5	$\pm 20\%$ (M)	---	7	7.96 MHz	110	0.18	550
NIN-PA2R2MTRF	2.2	$\pm 20\%$ (M)	---	7	7.96 MHz	80	0.23	500
NIN-PA3R3MTRF	3.3	$\pm 20\%$ (M)	---	7	7.96 MHz	56	0.28	400
NIN-PA4R7MTRF	4.7	$\pm 20\%$ (M)	---	7	7.96 MHz	46	0.34	350
NIN-PA6R8MTRF	6.8	$\pm 20\%$ (M)	---	7	7.96 MHz	38	0.42	300
NIN-PA100KTRF	10	$\pm 10\%$ (K)	---	15	2.52 MHz	23	0.50	240
NIN-PA120KTRF	12	$\pm 10\%$ (K)	---	15	2.52 MHz	21	0.60	230
NIN-PA150KTRF	15	$\pm 10\%$ (K)	---	15	2.52 MHz	18	0.74	220
NIN-PA180KTRF	18	$\pm 10\%$ (K)	---	15	2.52 MHz	17	0.90	205
NIN-PA220KTRF	22	$\pm 10\%$ (K)	---	15	2.52 MHz	15	1.15	185
NIN-PA270KTRF	27	$\pm 10\%$ (K)	---	15	2.52 MHz	13	1.45	165
NIN-PA330KTRF	33	$\pm 10\%$ (K)	---	15	2.52 MHz	12	1.65	155
NIN-PA390KTRF	39	$\pm 10\%$ (K)	---	15	2.52 MHz	11	1.90	145
NIN-PA470KTRF	47	$\pm 10\%$ (K)	---	15	2.52 MHz	9.5	2.25	135
NIN-PA560KTRF	56	$\pm 10\%$ (K)	---	15	2.52 MHz	8.5	3.30	110
NIN-PA680KTRF	68	$\pm 10\%$ (K)	---	15	2.52 MHz	7.5	3.70	105
NIN-PA820KTRF	82	$\pm 10\%$ (K)	---	15	2.52 MHz	7.0	4.20	100
NIN-PA101KTRF	100	$\pm 10\%$ (K)	---	20	0.796 MHz	6.5	5.00	90
NIN-PA121KTRF	120	$\pm 10\%$ (K)	---	20	0.796 MHz	6.0	7.00	75
NIN-PA151KTRF	150	$\pm 10\%$ (K)	---	20	0.796 MHz	5.5	8.00	70
NIN-PA181KTRF	180	$\pm 10\%$ (K)	---	20	0.796 MHz	5.0	9.50	65
NIN-PA221KTRF	220	$\pm 10\%$ (K)	---	20	0.796 MHz	4.0	11.0	60
NIN-PA271KTRF	270	$\pm 10\%$ (K)	---	20	0.796 MHz	3.5	14.5	55
NIN-PA331KTRF	330	$\pm 10\%$ (K)	---	20	0.796 MHz	3.0	16.0	50

For Quality Factor (Q) and Inductance (L)
over Frequency curves
see www.RFpassives.com

NIN-FB SERIES B-SIZE (1812) STANDARD VALUES

NIC P/N	'L' Inductance (μH)	Tolerance		'Q' Factor (min.)	L & Q Test Frequency	SRF MHz (min.)	DC Resistance (ohms) Max.	Rated DC Current (mA) Max.
		(std)	(opt)					
NIN-FBR10xTRF	0.10	±20% (M)	±10% (K)	28	25.2 MHz	700	0.44	450
NIN-FBR12xTRF	0.12	±20% (M)	±10% (K)	30	25.2 MHz	500	0.22	450
NIN-FBR15xTRF	0.15	±20% (M)	±10% (K)	30	25.2 MHz	450	0.25	450
NIN-FBR18xTRF	0.18	±20% (M)	±10% (K)	30	25.2 MHz	400	0.28	450
NIN-FBR22xTRF	0.22	±20% (M)	±10% (K)	30	25.2 MHz	350	0.32	450
NIN-FBR27xTRF	0.27	±20% (M)	±10% (K)	30	25.2 MHz	320	0.36	450
NIN-FBR33xTRF	0.33	±20% (M)	±10% (K)	30	25.2 MHz	300	0.40	450
NIN-FBR39xTRF	0.39	±20% (M)	±10% (K)	30	25.2 MHz	250	0.45	450
NIN-FBR47xTRF	0.47	±20% (M)	±10% (K)	30	25.2 MHz	220	0.50	450
NIN-FBR56xTRF	0.56	±20% (M)	±10% (K)	30	25.2 MHz	180	0.55	450
NIN-FBR68xTRF	0.68	±20% (M)	±10% (K)	30	25.2 MHz	160	0.60	450
NIN-FBR82xTRF	0.82	±20% (M)	±10% (K)	30	25.2 MHz	140	0.67	450
NIN-FB1R0xTRF	1.0	±20% (M)	±10% (K)	50	7.96 MHz	100	0.50	450
NIN-FB1R2xTRF	1.2	±20% (M)	±10% (K)	50	7.96 MHz	80	0.55	430
NIN-FB1R5xTRF	1.5	±20% (M)	±10% (K)	50	7.96 MHz	70	0.60	410
NIN-FB1R8xTRF	1.8	±20% (M)	±10% (K)	50	7.96 MHz	60	0.65	390
NIN-FB2R2xTRF	2.2	±20% (M)	±10% (K)	50	7.96 MHz	55	0.70	380
NIN-FB2R7xTRF	2.7	±20% (M)	±10% (K)	50	7.96 MHz	50	0.75	370
NIN-FB3R3xTRF	3.3	±20% (M)	±10% (K)	50	7.96 MHz	45	0.80	355
NIN-FB3R9xTRF	3.9	±20% (M)	±10% (K)	50	7.96 MHz	40	0.90	330
NIN-FB4R7xTRF	4.7	±20% (M)	±10% (K)	50	7.96 MHz	35	1.00	315
NIN-FB5R6xTRF	5.6	±20% (M)	±10% (K)	50	7.96 MHz	33	1.10	300
NIN-FB6R8xTRF	6.8	±20% (M)	±10% (K)	50	7.96 MHz	27	1.20	285
NIN-FB8R2xTRF	8.2	±20% (M)	±10% (K)	50	7.96 MHz	25	1.40	270

For Quality Factor (Q) and Inductance (L)
over Frequency curves
see www.RFpassives.com

NIN-FB SERIES B-SIZE (1812) STANDARD VALUES

NIC P/N	'L' Inductance (μH)	Tolerance		'Q' Factor (min.)	L & Q Test Frequency	SRF MHz (min.)	DC Resistance (ohms) Max.	Rated DC Current (mA) Max.
		(std)	(opt)					
NIN-FB100xTRF	10	±10% (K)	±5% (J)	50	2.52 MHz	20	1.60	250
NIN-FB120xTRF	12	±10% (K)	±5% (J)	50	2.52 MHz	18	2.00	225
NIN-FB150xTRF	15	±10% (K)	±5% (J)	50	2.52 MHz	17	2.50	200
NIN-FB180xTRF	18	±10% (K)	±5% (J)	50	2.52 MHz	15	2.80	190
NIN-FB220xTRF	22	±10% (K)	±5% (J)	50	2.52 MHz	13	3.20	180
NIN-FB270xTRF	27	±10% (K)	±5% (J)	50	2.52 MHz	12	3.60	170
NIN-FB330xTRF	33	±10% (K)	±5% (J)	50	2.52 MHz	11	4.00	160
NIN-FB390xTRF	39	±10% (K)	±5% (J)	50	2.52 MHz	10	4.50	150
NIN-FB470xTRF	47	±10% (K)	±5% (J)	50	2.52 MHz	10	5.00	140
NIN-FB560xTRF	56	±10% (K)	±5% (J)	50	2.52 MHz	9.3	5.50	135
NIN-FB680xTRF	68	±10% (K)	±5% (J)	50	2.52 MHz	9.0	6.00	130
NIN-FB820xTRF	82	±10% (K)	±5% (J)	50	2.52 MHz	8.2	7.00	120
NIN-FB101xTRF	100	±10% (K)	±5% (J)	40	1.50 MHz	6.7	8.80	110
NIN-FB121xTRF	120	±10% (K)	±5% (J)	40	1.50 MHz	6.1	10.0	110
NIN-FB151xTRF	150	±10% (K)	±5% (J)	40	1.50 MHz	5.5	11.0	105
NIN-FB181xTRF	180	±10% (K)	±5% (J)	40	1.50 MHz	5.1	13.0	102
NIN-FB221xTRF	220	±10% (K)	±5% (J)	40	0.796 MHz	4.5	13.0	100
NIN-FB271xTRF	270	±10% (K)	±5% (J)	40	0.796 MHz	4.1	14.0	85
NIN-FB331xTRF	330	±10% (K)	±5% (J)	40	0.796 MHz	3.7	16.0	85
NIN-FB391xTRF	390	±10% (K)	±5% (J)	40	0.796 MHz	3.3	19.0	80
NIN-FB471xTRF	470	±10% (K)	±5% (J)	40	0.796 MHz	3.3	31.0	55
NIN-FB561xTRF	560	±10% (K)	±5% (J)	30	0.796 MHz	2.7	31.0	50
NIN-FB681xTRF	680	±10% (K)	±5% (J)	30	0.796 MHz	2.5	39.0	50
NIN-FB821xTRF	820	±10% (K)	±5% (J)	30	0.796 MHz	2.4	45.0	30
NIN-FB102xTRF	1000	±10% (K)	±5% (J)	30	0.796 MHz	2.1	53.0	30

CARRIER TAPE DIMENSIONS (mm)

Case Code	Type	Size	W±0.3	A±0.2	B±0.2	P±0.1	E±0.1	F±0.1	t1	t2
D	ND	0805	8.0	1.45	2.25	4.0	1.75	3.5	0.25	1.55
C	FC/NC/PC	1008	8.0	2.4	2.9	4.0	1.75	3.5	0.25	1.85
A	FA/NA/PA	1210	8.0	2.8	3.6	4.0	1.75	3.5	0.25	2.40
B	FB	1812	12.0	3.6	4.9	8.0	1.75	5.5	0.30	3.50

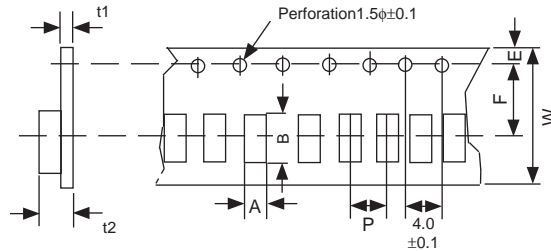

DIMENSIONS (mm)

Case Code	Type	Size	Dφ±2.0	W±1.5	Qty/Reel
D	ND	0805	180	9.0	3000 pcs
C	FC/NC/PC	1008	180	9.0	2000 pcs
A	FA/NA/PA	1210	180	9.0	2000 pcs
B	FB	1812	180	13.0	500 pcs

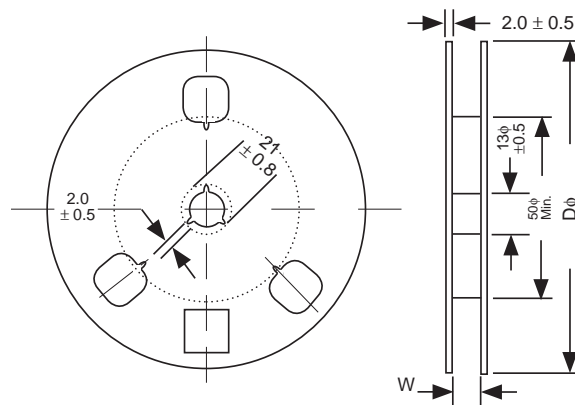

RECOMMENDED LAND PATTERNS FOR FLOW AND REFLOW SOLDERING

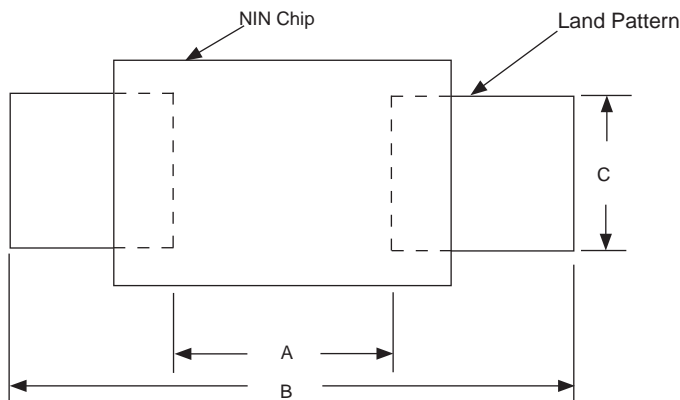

DIMENSIONS (mm)

Case Code	Type	Size	A	B	C
D	ND	0805	1.0~1.2	3.0~3.8	0.9~1.3
C	FC/NC/PC	1008	1.4~1.5	3.5~4.0	1.2~1.6
A	FA/NA/PA	1210	1.6~2.0	4.0~4.6	1.9~2.4
B	FB	1812	2.4~2.6	5.5~6.0	2.0~3.0