

DATA SHEET

HAL501...506, 508, 509,
HAL516...519, 523
Hall Effect Sensor Family

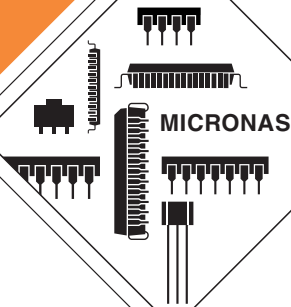

Edition Nov. 27, 2003
6251-485-4DS

 MICRONAS

Contents

Page	Section	Title
3	1.	Introduction
3	1.1.	Features
3	1.2.	Family Overview
4	1.3.	Marking Code
4	1.3.1.	Special Marking of Prototype Parts
4	1.4.	Operating Junction Temperature Range
4	1.5.	Hall Sensor Package Codes
4	1.6.	Solderability
5	2.	Functional Description
6	3.	Specifications
6	3.1.	Outline Dimensions
11	3.2.	Dimensions of Sensitive Area
11	3.3.	Positions of Sensitive Areas
11	3.4.	Absolute Maximum Ratings
11	3.4.1.	Storage and Shelf Life
12	3.5.	Recommended Operating Conditions
13	3.6.	Characteristics
14	3.7.	Magnetic Characteristics Overview
20	4.	Type Descriptions
20	4.1.	HAL501
22	4.2.	HAL502
24	4.3.	HAL503
26	4.4.	HAL504
28	4.5.	HAL505
30	4.6.	HAL506
32	4.7.	HAL508
34	4.8.	HAL509
36	4.9.	HAL516
38	4.10.	HAL517
40	4.11.	HAL518
42	4.12.	HAL519
44	4.13.	HAL523
46	5.	Application Notes
46	5.1.	Ambient Temperature
46	5.2.	Extended Operating Conditions
46	5.3.	Start-up Behavior
46	5.4.	EMC
48	6.	Data Sheet History

Hall Effect Sensor Family
in CMOS technology

Release Notes: Revision bars indicate significant changes to the previous edition.

1. Introduction

The HAL5xx family consists of different Hall switches produced in CMOS technology. All sensors include a temperature-compensated Hall plate with active offset compensation, a comparator, and an open-drain output transistor. The comparator compares the actual magnetic flux through the Hall plate (Hall voltage) with the fixed reference values (switching points). Accordingly, the output transistor is switched on or off.

The sensors of this family differ in the switching behavior and the switching points.

The active offset compensation leads to constant magnetic characteristics over supply voltage and temperature range. In addition, the magnetic parameters are robust against mechanical stress effects.

The sensors are designed for industrial and automotive applications and operate with supply voltages from 3.8 V to 24 V in the ambient temperature range from -40 °C up to 150 °C.

All sensors are available in the SMD-package SOT89B-1 and in the leaded versions TO92UA-1 and TO92UA-2.

1.1. Features:

- switching offset compensation at typically 62 kHz
- operates from 3.8 V to 24 V supply voltage
- overvoltage protection at all pins
- reverse-voltage protection at V_{DD}-pin
- magnetic characteristics are robust regarding mechanical stress effects
- short-circuit protected open-drain output by thermal shut down
- operates with static magnetic fields and dynamic magnetic fields up to 10 kHz
- constant switching points over a wide supply voltage range
- the decrease of magnetic flux density caused by rising temperature in the sensor system is compensated by a built-in negative temperature coefficient of the magnetic characteristics
- ideal sensor for applications in extreme automotive and industrial environments
- EMC corresponding to DIN 40839

1.2. Family Overview

The types differ according to the magnetic flux density values for the magnetic switching points, the temperature behavior of the magnetic switching points, and the mode of switching.

Type	Switching Behavior	Sensitivity	see Page
501	bipolar	very high	20
502	latching	high	22
503	latching	medium	24
504	unipolar	medium	26
505	latching	low	28
506	unipolar	high	30
508	unipolar	medium	32
509	unipolar	low	34
516	unipolar with inverted output	high	36
517	unipolar with inverted output	medium	38
518	unipolar with inverted output	medium	40
519	unipolar with inverted output (north polarity)	high	42
523	unipolar	low	44

Latching Sensors:

The output turns low with the magnetic south pole on the branded side of the package and turns high with the magnetic north pole on the branded side. The output does not change if the magnetic field is removed. For changing the output state, the opposite magnetic field polarity must be applied.

Bipolar Switching Sensors:

The output turns low with the magnetic south pole on the branded side of the package and turns high with the magnetic north pole on the branded side. The output state is not defined for all sensors if the magnetic field is removed again. Some sensors will change the output state and some sensors will not.

Unipolar Switching Sensors:

The output turns low with the magnetic south pole on the branded side of the package and turns high if the magnetic field is removed. The sensor does not respond to the magnetic north pole on the branded side.

Unipolar Switching Sensors with Inverted Output:

The output turns high with the magnetic south pole on the branded side of the package and turns low if the magnetic field is removed. The sensor does not respond to the magnetic north pole on the branded side.

Unipolar Switching Sensors with Inverted Output Sensitive to North Pole:

The output turns high with the magnetic north pole on the branded side of the package and turns low if the magnetic field is removed. The sensor does not respond to the magnetic south pole on the branded side.

1.3. Marking Code

All Hall sensors have a marking on the package surface (branded side). This marking includes the name of the sensor and the temperature range.

Type	Temperature Range	
	A	K
HAL501	501A	501K
HAL502	502A	502K
HAL503	503A	503K
HAL504	504A	504K
HAL505	505A	505K
HAL506	506A	506K
HAL508	508A	508K
HAL509	509A	509K
HAL516	516A	516K
HAL517	517A	517K
HAL518	518A	518K
HAL519	519A	519K
HAL523	523A	523K

1.3.1. Special Marking of Prototype Parts

Prototype parts are coded with an underscore beneath the temperature range letter on each IC. They may be used

for lab experiments and design-ins but are not intended to be used for qualification tests or as production parts.

1.4. Operating Junction Temperature Range

The Hall sensors from Micronas are specified to the chip temperature (junction temperature T_J).

A: $T_J = -40\text{ °C to }+170\text{ °C}$

K: $T_J = -40\text{ °C to }+140\text{ °C}$

Note: Due to the high power dissipation at high current consumption, there is a difference between the ambient temperature (T_A) and junction temperature. Please refer to section 5.1. on page 46 for details.

1.5. Hall Sensor Package Codes

HALXXXPA-T

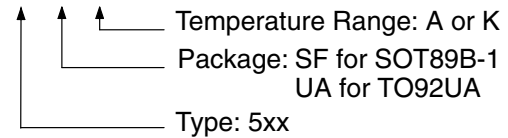

Example: **HAL505UA-K**

- Type: 505
- Package: TO92UA
- Temperature Range: $T_J = -40\text{ °C to }+140\text{ °C}$

Hall sensors are available in a wide variety of packaging versions and quantities. For more detailed information, please refer to the brochure: “Ordering Codes for Hall Sensors”.

1.6. Solderability

all packages: according to IEC68-2-58

During soldering reflow processing and manual reworking, a component body temperature of 260 °C should not be exceeded.

Components stored in the original packaging should provide a shelf life of at least 12 months, starting from the date code printed on the labels, even in environments as extreme as 40 °C and 90% relative humidity.

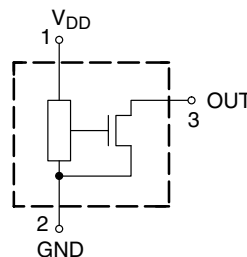

Fig. 1–1: Pin configuration

2. Functional Description

The HAL5xx sensors are monolithic integrated circuits which switch in response to magnetic fields. If a magnetic field with flux lines perpendicular to the sensitive area is applied to the sensor, the biased Hall plate forces a Hall voltage proportional to this field. The Hall voltage is compared with the actual threshold level in the comparator. The temperature-dependent bias increases the supply voltage of the Hall plates and adjusts the switching points to the decreasing induction of magnets at higher temperatures. If the magnetic field exceeds the threshold levels, the open drain output switches to the appropriate state. The built-in hysteresis eliminates oscillation and provides switching behavior of output without bouncing.

Magnetic offset caused by mechanical stress is compensated for by using the “switching offset compensation technique”. Thus, an internal oscillator provides a two-phase clock. The Hall voltage is sampled at the end of the first phase. At the end of the second phase, both sampled and actual Hall voltages are averaged and compared with the actual switching point. Subsequently, the open drain output switches to the appropriate state. The time from crossing the magnetic switching level to switching of output can vary between zero and $1/f_{osc}$.

Shunt protection devices clamp voltage peaks at the Output-Pin and V_{DD} -Pin together with external series resistors. Reverse current is limited at the V_{DD} -Pin by an internal series resistor up to -15 V . No external reverse protection diode is needed at the V_{DD} -Pin for reverse voltages ranging from 0 V to -15 V .

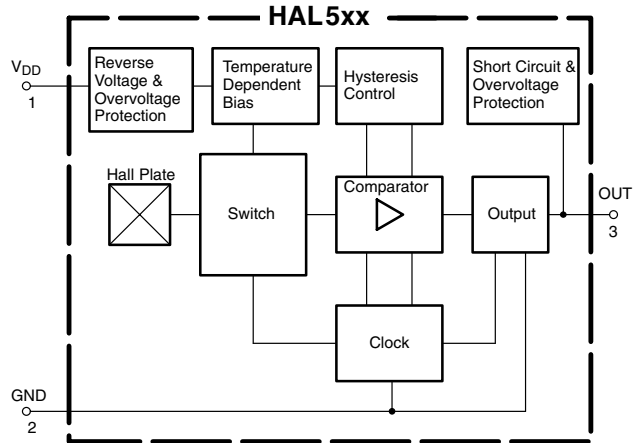

Fig. 2-1: HAL5xx block diagram

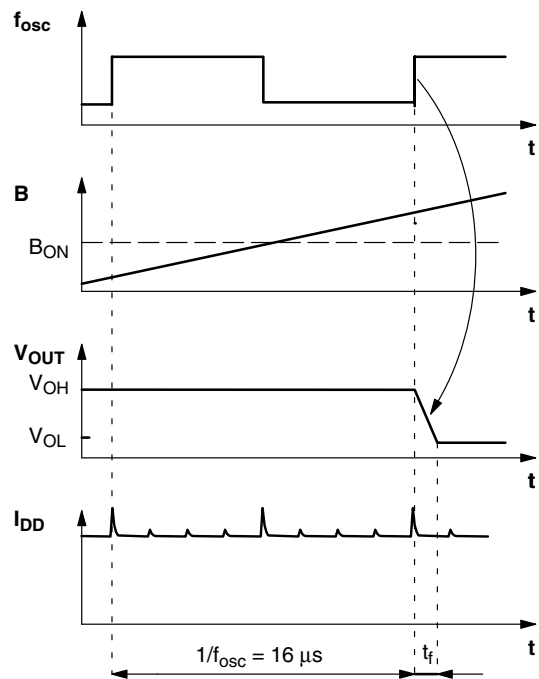
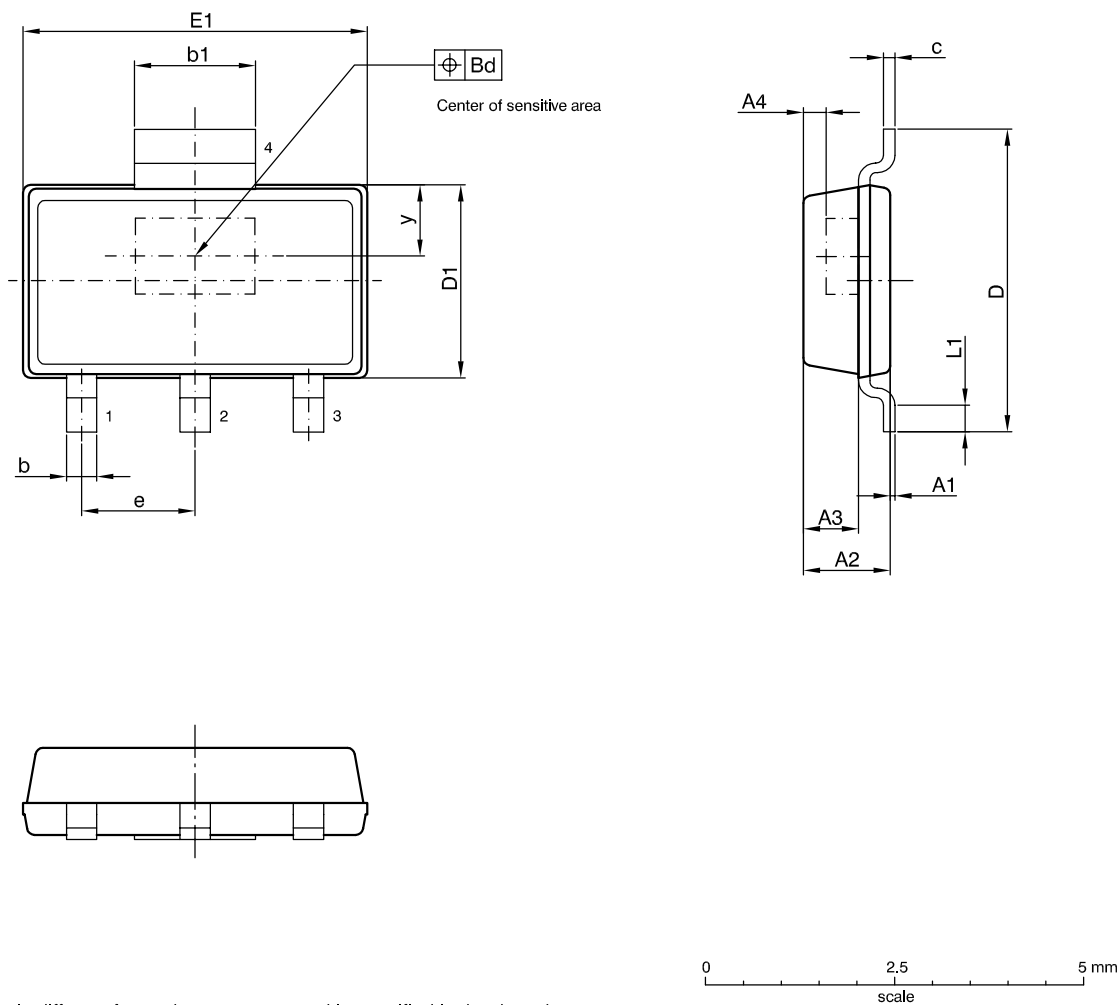

Fig. 2-2: Timing diagram

3. Specifications

3.1. Outline Dimensions



y= this dimension is different for each sensor type and is specified in the data sheet.

UNIT	A1	A2	A3	A4	b	b1	Bd	c	D	D1	e	E1	L1
mm	0.10 0.02	1.20 1.10	0.755 0.705	0.3	0.4	1.7	0.2	0.15	4.0	2.6 2.5	1.5	4.6 4.5	0.25 min.

JEDEC STANDARD		ANSI	ISSUE DATE YY-MM-DD	DRAWING-NO.	SPZG-NO.
ISSUE	ITEM NO.				
-	-		03-03-10	06610.0001.4	SPZG001010_001_01

Fig. 3-1:
SOT89B-1: Plastic Small Outline Transistor package, 4 leads
 Weight approximately 0.039 g

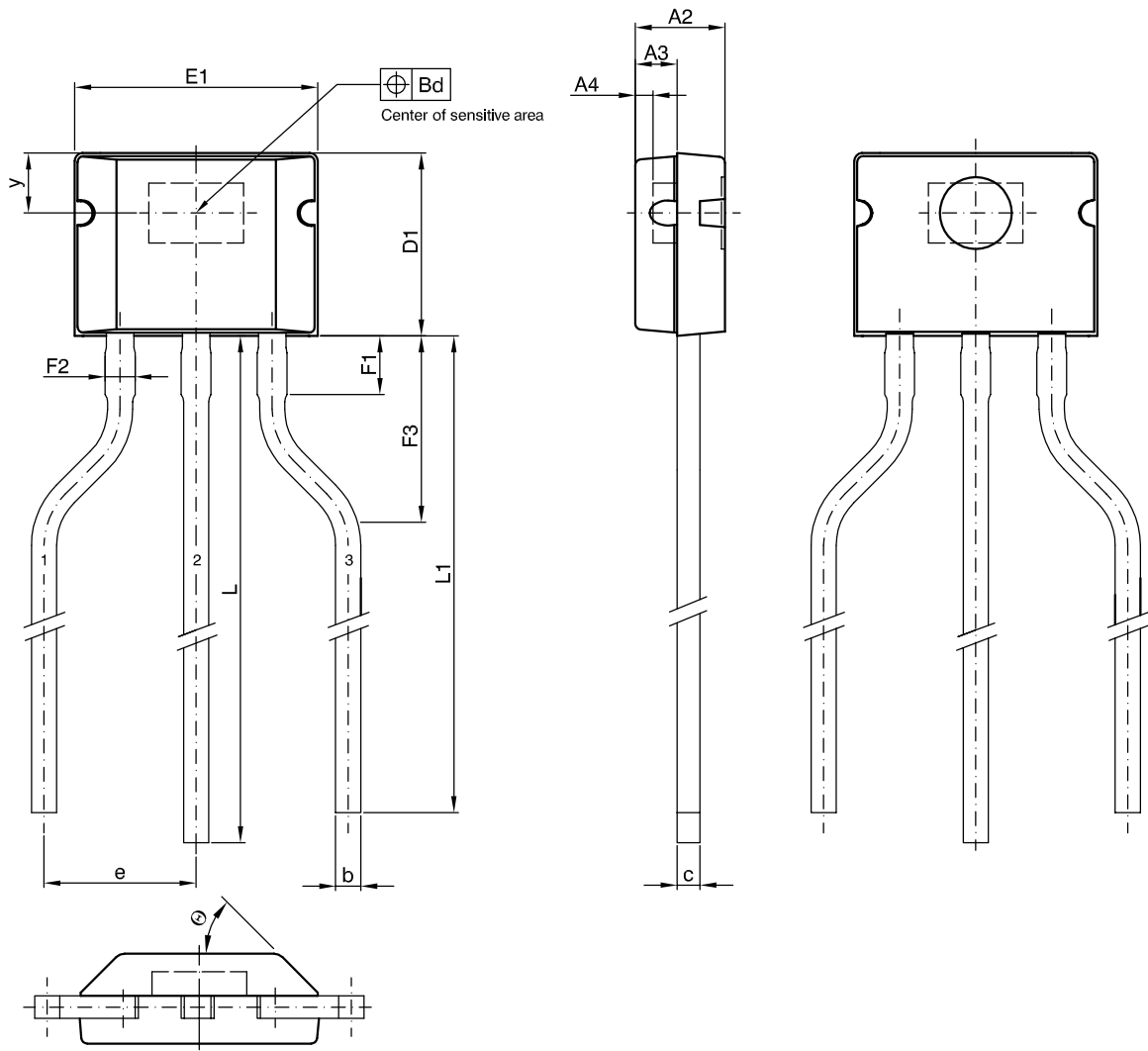

solderability is guaranteed between end of pin and distance F1.
 y= this dimension is different for each sensor type and is specified in the data sheet.

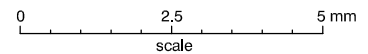

UNIT	A2	A3	A4	b	Bd	c	D1	e	E1	F1	F2	F3	L	L1	θ
mm	1.55 1.45	0.7	0.3	0.42	0.2	0.36	3.1 3.0	2.54	4.11 4.01	1.2 0.8	0.60 0.42	4.0 2.0	15.5 mln	14.5 mln	45°

JEDEC STANDARD		ANSI	ISSUE DATE YY-MM-DD	DRAWING-NO.	SPZG-NO.
ISSUE	ITEM NO.				
-	-		03-11-18	06616.0001.4	SPZG001016_001_02

Fig. 3-2:
TO92UA-1: Plastic Transistor Standard UA package, 3 leads, spread
 Weight approximately 0.105 g

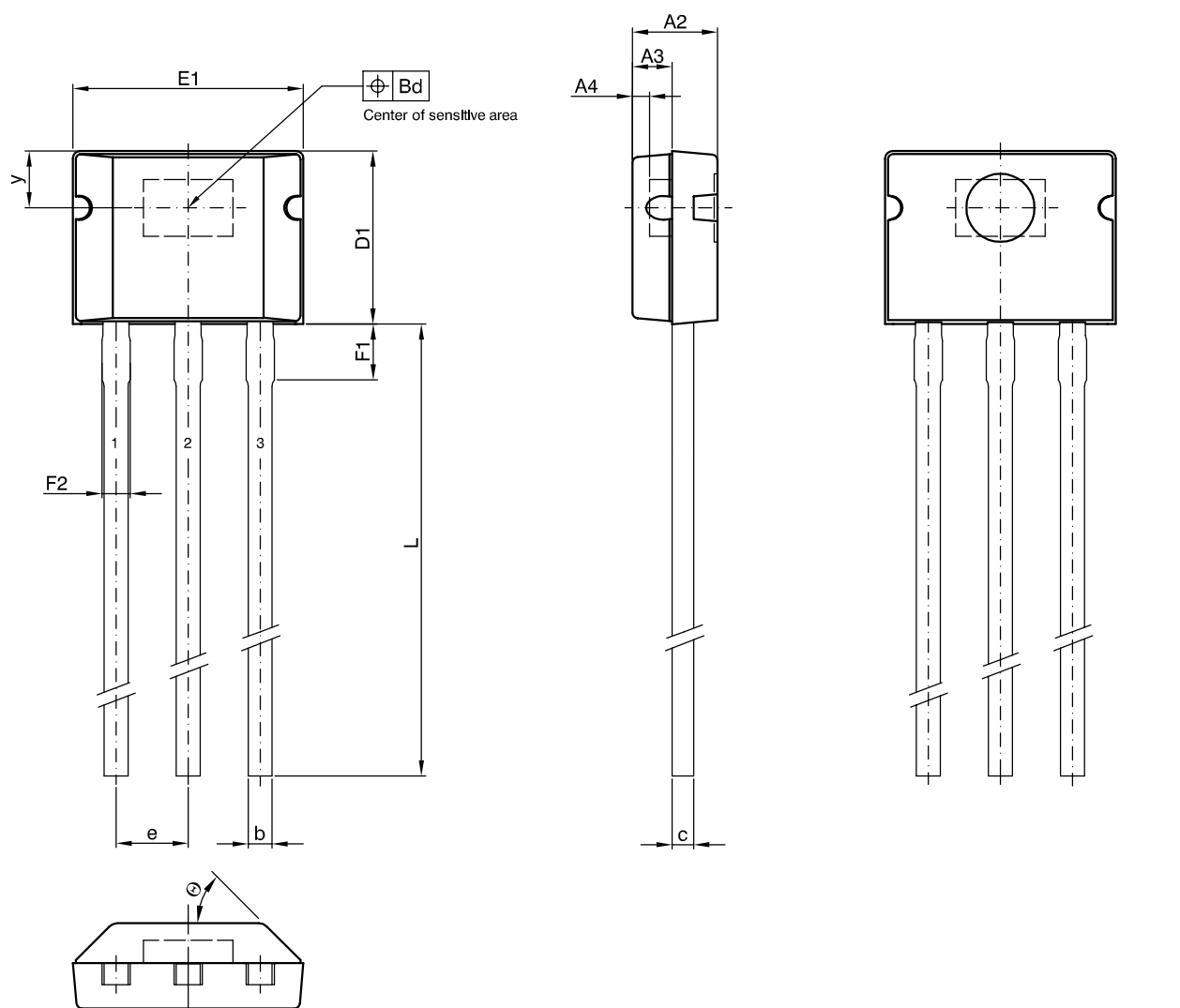

solderability is guaranteed between end of pin and distance F1.
 y= this dimension is different for each sensor type and is specified in the data sheet.

UNIT	A2	A3	A4	b	Bd	c	D1	e	E1	F1	F2	L	θ
mm	1.55 1.45	0.7	0.3	0.42	0.2	0.36	3.1 3.0	1.27	4.11 4.01	1.2 0.8	0.60 0.42	15.5 min	45°

JEDEC STANDARD		ANSI	ISSUE DATE YY-MM-DD	DRAWING-NO.	SPZG-NO.
ISSUE	ITEM NO.				
-	-		03-11-18	06612.0001.4	SPZG001012_001_03

Fig. 3-3:
TO92UA-2: Plastic Transistor Standard UA package, 3 leads
 Weight approximately 0.105 g

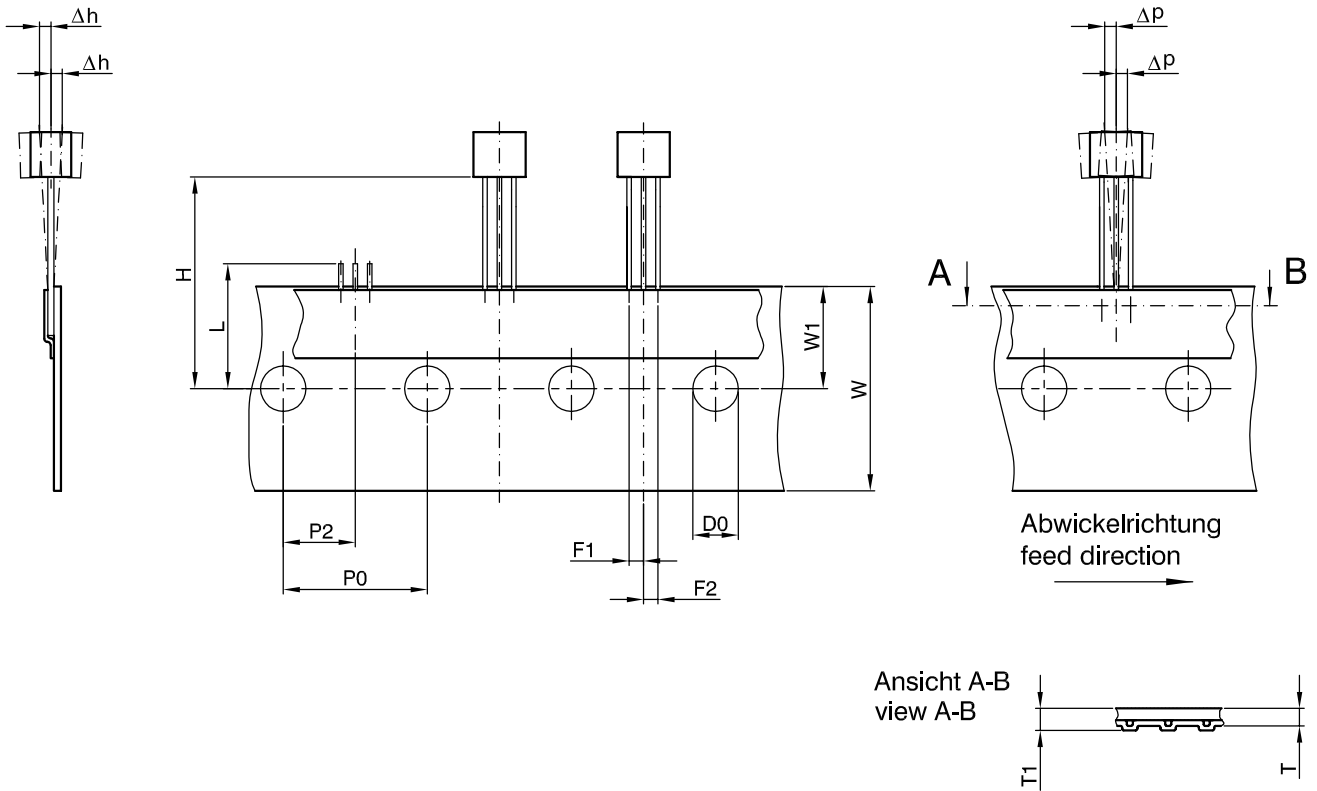

alle Maße in mm / all dimensions in mm
 max. zul. Abweichung über 20 Lochabstände ± 1.0 / max. allowed tolerance over 20 hole spacings ± 1.0

UNIT	D0	F1	F2	H	Δh	L	P0	P2	Δp	T	T1	W	W1
mm	4.0	1.47 1.07	1.47 1.07	20.0 18.0	± 1.0	11.0 max	13.2 12.2	7.05 5.65	± 1.0	0.5	0.9	18.0	9.0

JEDEC STANDARD		ANSI	ISSUE DATE YY-MM-DD	DRAWING-NO.	SPZG-NO.
ISSUE	ITEM NO.				
-	ICE 60286-2		03-09-12	06631.0001.4	SPZG001031_001_02

Fig. 3-4:
TO92UA-2: Dimensions ammpack inline, not spread

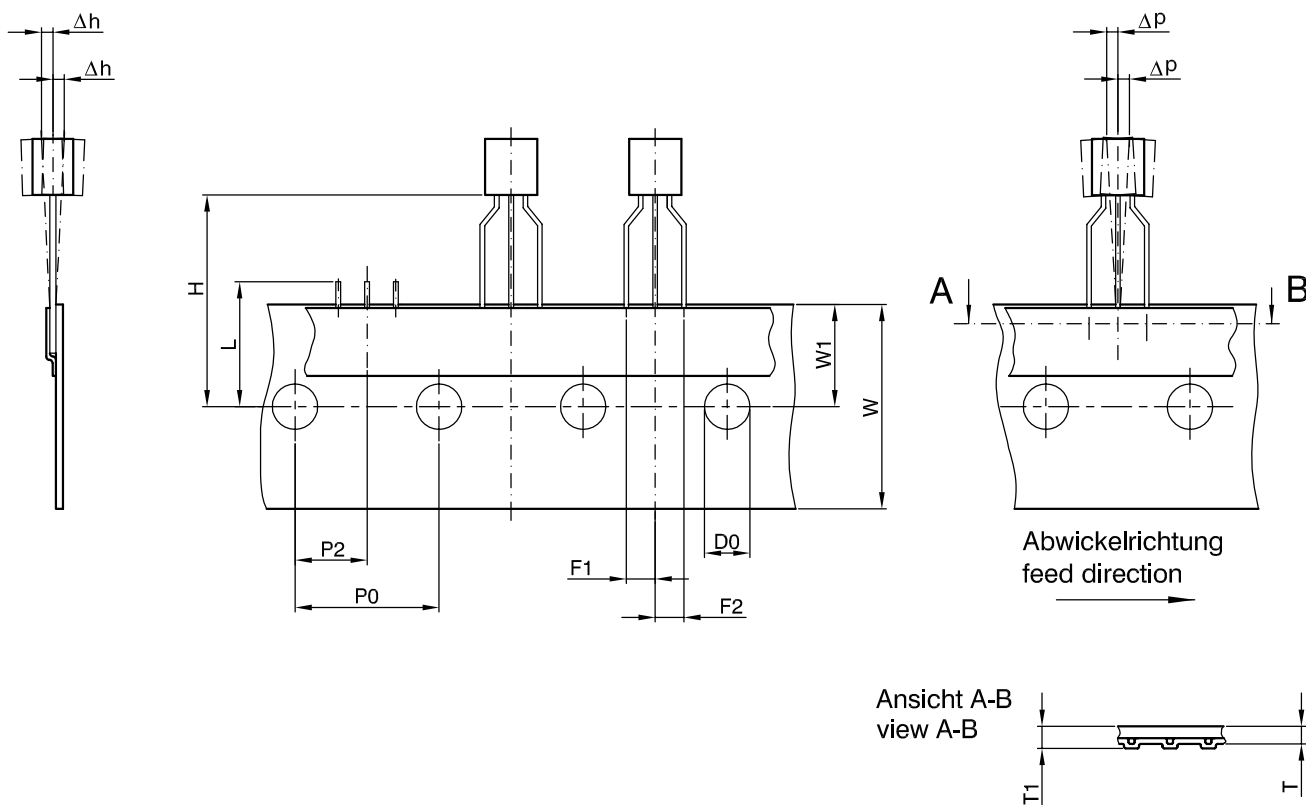

alle Maße in mm / all dimensions in mm
 max. zul. Abweichung über 20 Lochabstände ±1.0 / max. allowed tolerance over 20 hole spacings ±1.0

UNIT	D0	F1	F2	H	Δh	L	P0	P2	Δp	T	T1	W	W1
mm	4.0	2.74 2.34	2.74 2.34	20.0 18.0	±1.0	11.0 max	13.2 12.2	7.05 5.65	±1.0	0.5	0.9	18.0	9.0

JEDEC STANDARD		ANSI	ISSUE DATE YY-MM-DD	DRAWING-NO.	SPZG-NO.
ISSUE	ITEM NO.				
-	ICE 60286-2		03-09-12	06632.0001.4	SPZG001032_001_02

Fig. 3-5:
TO92U-1: Dimensions ammpack inline, spread

3.2. Dimensions of Sensitive Area

0.25 mm x 0.12 mm

3.3. Positions of Sensitive Areas

	SOT89B-1	TO92UA-1/-2
x	center of the package	center of the package
y	0.95 mm nominal	1.0 mm nominal

3.4. Absolute Maximum Ratings

Stresses beyond those listed in the “Absolute Maximum Ratings” may cause permanent damage to the device. This is a stress rating only. Functional operation of the device at these conditions is not implied. Exposure to absolute maximum rating conditions for extended periods will affect device reliability.

This device contains circuitry to protect the inputs and outputs against damage due to high static voltages or electric fields; however, it is advised that normal precautions be taken to avoid application of any voltage higher than absolute maximum-rated voltages to this circuit.

All voltages listed are referenced to ground.

Symbol	Parameter	Pin No.	Limit Values		Unit
			Min.	Max.	
V _{DD}	Supply Voltage	1	-15	28 ¹⁾	V
V _O	Output Voltage	3	-0.3	28 ¹⁾	V
I _O	Continuous Output On Current	3	-	50 ¹⁾	mA
T _J	Junction Temperature Range		-40	170 ²⁾	°C
1) as long as T _{Jmax} is not exceeded 2) t < 1000 h					

3.4.1. Storage and Shelf Life

The permissible storage time (shelf life) of the sensors is unlimited, provided the sensors are stored at a maximum of 30 °C and a maximum of 85% relative humidity. At these conditions, no Dry Pack is required.

Solderability is guaranteed for one year from the date code on the package. Solderability has been tested after storing the devices for 16 hours at 155 °C. The wettability was more than 95%.

3.5. Recommended Operating Conditions

Functional operation of the device beyond those indicated in the “Recommended Operating Conditions” of this specification is not implied, may result in unpredictable behavior of the device and may reduce reliability and lifetime.

All voltages listed are referenced to ground.

Symbol	Parameter	Pin No.	Limit Values		Unit
			Min.	Max.	
V_{DD}	Supply Voltage	1	3.8	24	V
I_O	Continuous Output On Current	3	0	20	mA
V_O	Output Voltage (output switched off)	3	0	24	V

3.6. Characteristics at $T_J = -40\text{ }^\circ\text{C}$ to $+170\text{ }^\circ\text{C}$, $V_{DD} = 3.8\text{ V}$ to 24 V , at Recommended Operation Conditions if not otherwise specified in the column “Conditions”. Typical Characteristics for $T_J = 25\text{ }^\circ\text{C}$ and $V_{DD} = 12\text{ V}$

Symbol	Parameter	Pin No.	Limit Values			Unit	Conditions
			Min.	Typ.	Max.		
I_{DD}	Supply Current	1	2.3	3	4.2	mA	$T_J = 25\text{ }^\circ\text{C}$
I_{DD}	Supply Current over Temperature Range	1	1.6	3	5.2	mA	
V_{DDZ}	Overvoltage Protection at Supply	1	–	28.5	32	V	$I_{DD} = 25\text{ mA}$, $T_J = 25\text{ }^\circ\text{C}$, $t = 20\text{ ms}$
V_{OZ}	Overvoltage Protection at Output	3	–	28	32	V	$I_{OH} = 25\text{ mA}$, $T_J = 25\text{ }^\circ\text{C}$, $t = 20\text{ ms}$
V_{OL}	Output Voltage	3	–	130	280	mV	$I_{OL} = 20\text{ mA}$, $T_J = 25\text{ }^\circ\text{C}$
V_{OL}	Output Voltage over Temperature Range	3	–	130	400	mV	$I_{OL} = 20\text{ mA}$
I_{OH}	Output Leakage Current	3	–	0.06	0.1	μA	Output switched off, $T_J = 25\text{ }^\circ\text{C}$, $V_{OH} = 3.8\text{ to }24\text{ V}$
I_{OH}	Output Leakage Current over Temperature Range	3	–	–	10	μA	Output switched off, $T_J \leq 150\text{ }^\circ\text{C}$, $V_{OH} = 3.8\text{ to }24\text{ V}$
f_{osc}	Internal Oscillator Chopper Frequency	–	–	62	–	kHz	
$t_{en(O)}$	Enable Time of Output after Setting of V_{DD}	1	–	50	–	μs	$V_{DD} = 12\text{ V}$ ¹⁾
t_r	Output Rise Time	3	–	75	400	ns	$V_{DD} = 12\text{ V}$, $R_L = 820\text{ Ohm}$, $C_L = 20\text{ pF}$
t_f	Output Fall Time	3	–	50	400	ns	$V_{DD} = 12\text{ V}$, $R_L = 820\text{ Ohm}$, $C_L = 20\text{ pF}$
R_{thJSB} case SOT89B-1	Thermal Resistance Junction to Substrate Backside	–	–	150	200	K/W	Fiberglass Substrate 30 mm x 10 mm x 1.5mm, pad size see Fig. 3–6
R_{thJA} case TO92UA-1, TO92UA-2	Thermal Resistance Junction to Soldering Point	–	–	150	200	K/W	

1) $B > B_{ON} + 2\text{ mT}$ or $B < B_{OFF} - 2\text{ mT}$ for HAL 50x, $B > B_{OFF} + 2\text{ mT}$ or $B < B_{ON} - 2\text{ mT}$ for HAL 51x

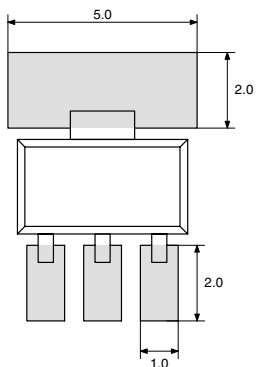

Fig. 3–6: Recommended pad size SOT89B-1
Dimensions in mm

3.7. Magnetic Characteristics Overview at $T_J = -40\text{ °C}$ to $+170\text{ °C}$, $V_{DD} = 3.8\text{ V}$ to 24 V ,
 Typical Characteristics for $V_{DD} = 12\text{ V}$

Magnetic flux density values of switching points.

Positive flux density values refer to the magnetic south pole at the branded side of the package.

Sensor Switching type	Parameter T_J	On point B_{ON}			Off point B_{OFF}			Hysteresis B_{HYS}			Unit
		Min.	Typ.	Max.	Min.	Typ.	Max.	Min.	Typ.	Max.	
HAL 501 bipolar	-40 °C	-0.8	0.6	2.5	-2.5	-0.8	0.8	0.5	1.4	2	mT
	25 °C	-0.5	0.5	2.3	-2.3	-0.7	0.5	0.5	1.2	1.9	mT
	170 °C	-1.5	0.7	3	-2.5	-0.2	2	0.4	0.9	1.8	mT
HAL 502 latching	-40 °C	1	2.8	5	-5	-2.8	-1	4.5	5.6	7.2	mT
	25 °C	1	2.6	4.5	-4.5	-2.6	-1	4.5	5.2	7	mT
	170 °C	0.9	2.3	4.3	-4.3	-2.3	-0.9	3.5	4.6	6.8	mT
HAL 503 latching	-40 °C	6.4	8.6	10.8	-10.8	-8.6	-6.4	14.6	17.2	20.6	mT
	25 °C	6	8	10	-10	-8	-6	13.6	16	18	mT
	170 °C	4	6.4	8.9	-8.9	-6	-4	11	12.4	16	mT
HAL 504 unipolar	-40 °C	10.3	13	15.7	5.3	7.5	9.6	4.4	5.5	6.5	mT
	25 °C	9.5	12	14.5	5	7	9	4	5	6.5	mT
	170 °C	8.5	10.2	13.7	4.2	5.9	8.5	3.2	4.3	6.4	mT
HAL 505 latching	-40 °C	11.8	15	18.3	-18.3	-15	-11.8	26	30	34	mT
	25 °C	11	13.5	17	-17	-13.5	-11	24	27	32	mT
	170 °C	9.4	11.7	16.1	-16.1	-11.7	-9.4	20	23.4	31.3	mT
HAL 506 unipolar	-40 °C	4.3	5.9	7.7	2.1	3.8	5.4	1.6	2.1	2.8	mT
	25 °C	3.8	5.5	7.2	2	3.5	5	1.5	2	2.7	mT
	170 °C	3.2	4.6	6.8	1.7	3	5.2	0.9	1.6	2.6	mT
HAL 508 unipolar	-40 °C	15.5	19	21.9	14	16.7	20	1.6	2.3	2.8	mT
	25 °C	15	18	20.7	13.5	16	19	1.5	2	2.7	mT
	170 °C	12.7	15.3	20	11.4	13.6	18.3	1	1.7	2.6	mT
HAL 509 unipolar	-40 °C	23.1	27.4	31.1	19.9	23.8	27.2	2.9	3.6	3.9	mT
	25 °C	23.1	26.8	30.4	19.9	23.2	26.6	2.8	3.5	3.9	mT
	170 °C	21.3	25.4	28.9	18.3	22.1	25.3	2.5	3.3	3.8	mT
HAL 516 unipolar inverted	-40 °C	2.1	3.8	5.4	4.3	5.9	7.7	1.6	2.1	2.8	mT
	25 °C	2	3.5	5	3.8	5.5	7.2	1.5	2	2.7	mT
	170 °C	1.7	3	5.2	3.2	4.6	6.8	0.9	1.6	2.6	mT
HAL 517 unipolar inverted	-40 °C	14	17.1	21.5	15.5	19.6	22.5	1.6	2.5	3	mT
	25 °C	13.5	16.2	19	15	18.3	20.7	1.5	2.1	2.7	mT
	170 °C	9	12.3	18	10.5	13.7	20	0.8	1.4	2.4	mT
HAL 518 unipolar inverted	-40 °C	14	16.7	20	15.5	19	22	1.5	2.3	3	mT
	25 °C	13.5	16	19	15	18	20.7	1.4	2	2.8	mT
	170 °C	11	13.6	18.3	12.2	15.3	20	0.8	1.7	2.6	mT

Note: For detailed descriptions of the individual types, see pages 20 and following.

Magnetic Characteristics Overview, continued

Sensor Switching type	Parameter T_J	On point B_{ON}			Off point B_{OFF}			Hysteresis B_{HYS}			Unit
		Min.	Typ.	Max.	Min.	Typ.	Max.	Min.	Typ.	Max.	
HAL 519 unipolar inverted	-40 °C	-5.4	-3.8	-2.1	-7.7	-5.9	-4.3	1.6	2.1	2.8	mT
	25 °C	-5	-3.6	-2	-7.2	-5.5	-3.8	1.5	1.9	2.7	mT
	170 °C	-5.2	-3.0	-1.5	-6.8	-4.6	-2.8	0.9	1.6	2.6	mT
HAL 523 unipolar	-40 °C	28	34.5	42	18	24	30	7	10.5	14	mT
	25 °C	28	34.5	42	18	24	30	7	10.5	14	mT
	170 °C	28	34.5	42	18	24	30	7	10.5	14	mT

Note: For detailed descriptions of the individual types, see pages 20 and following.

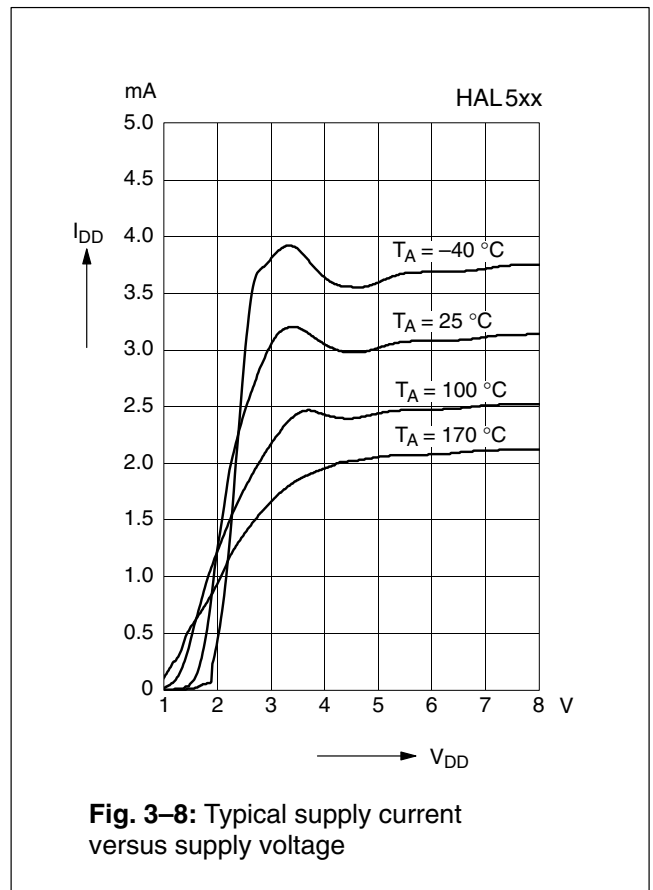
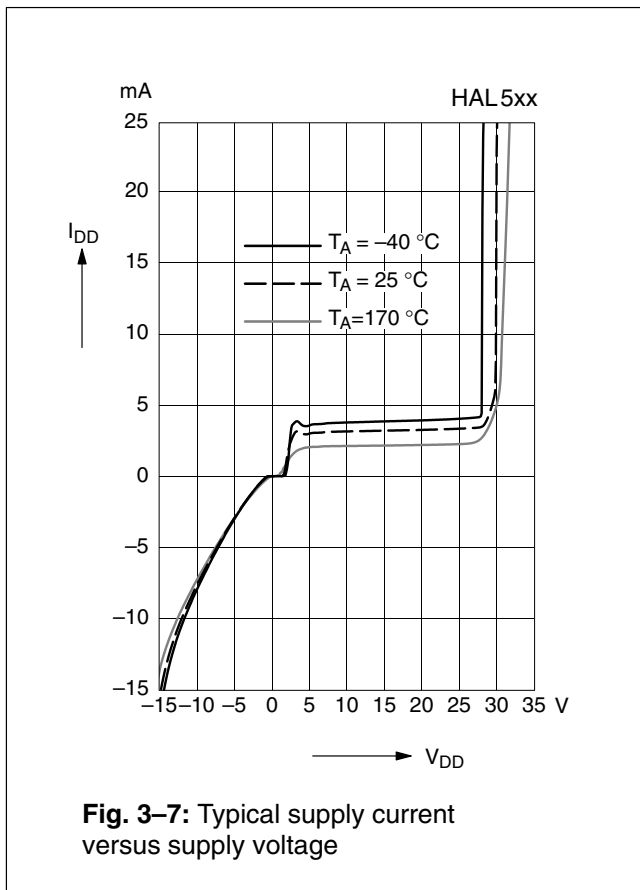

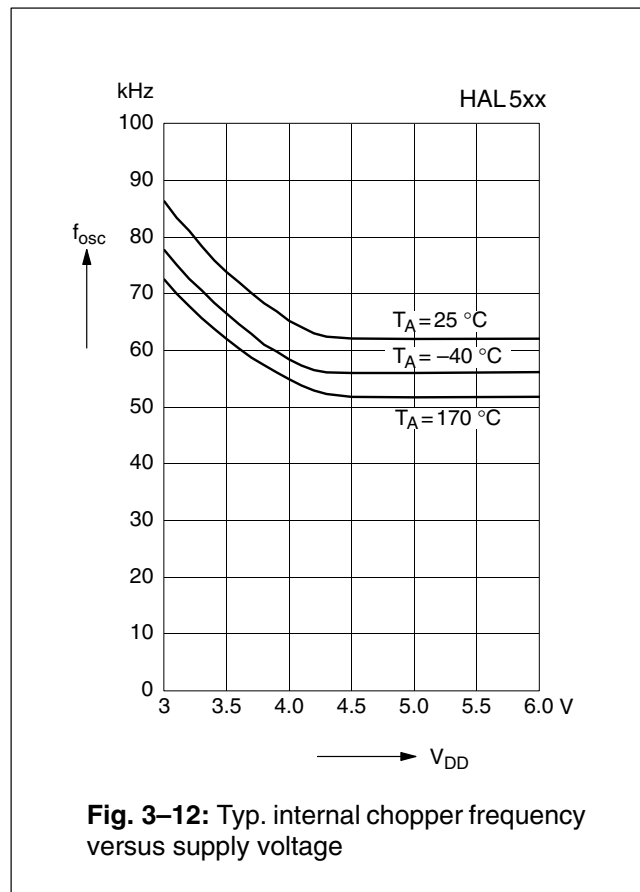
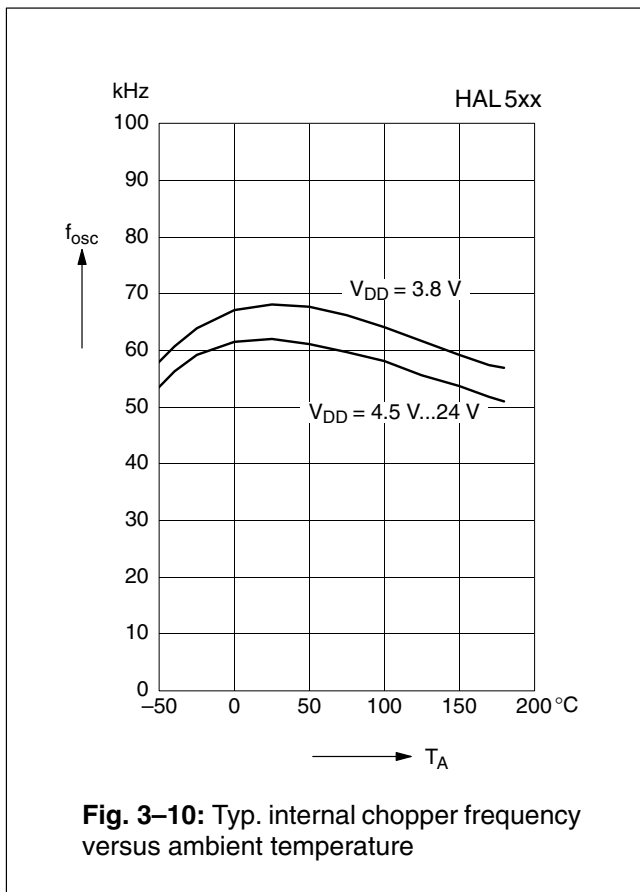
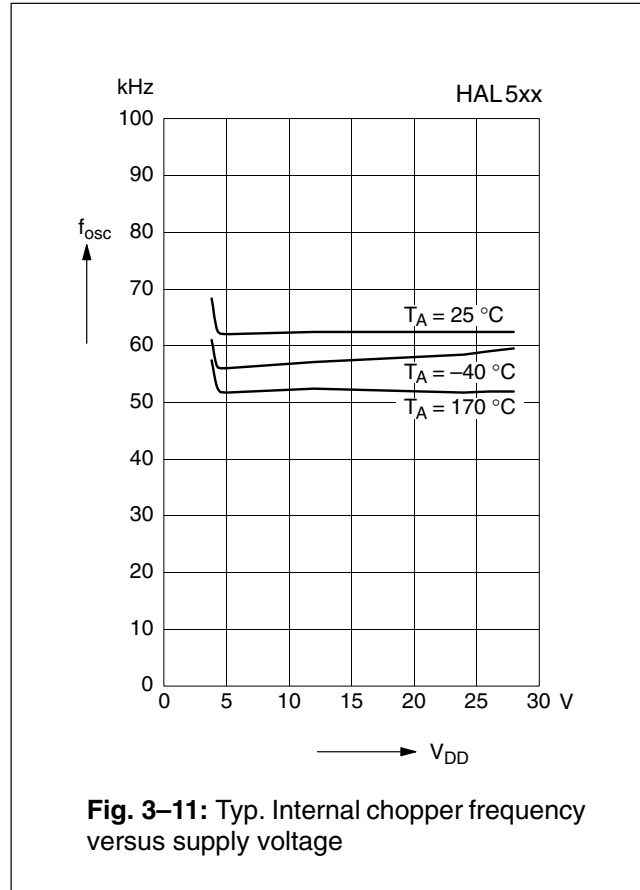
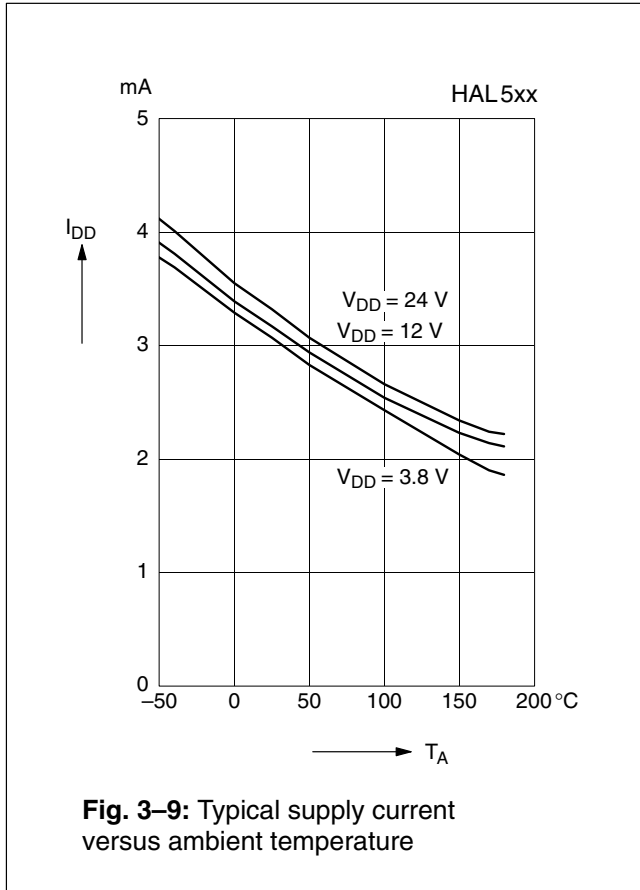

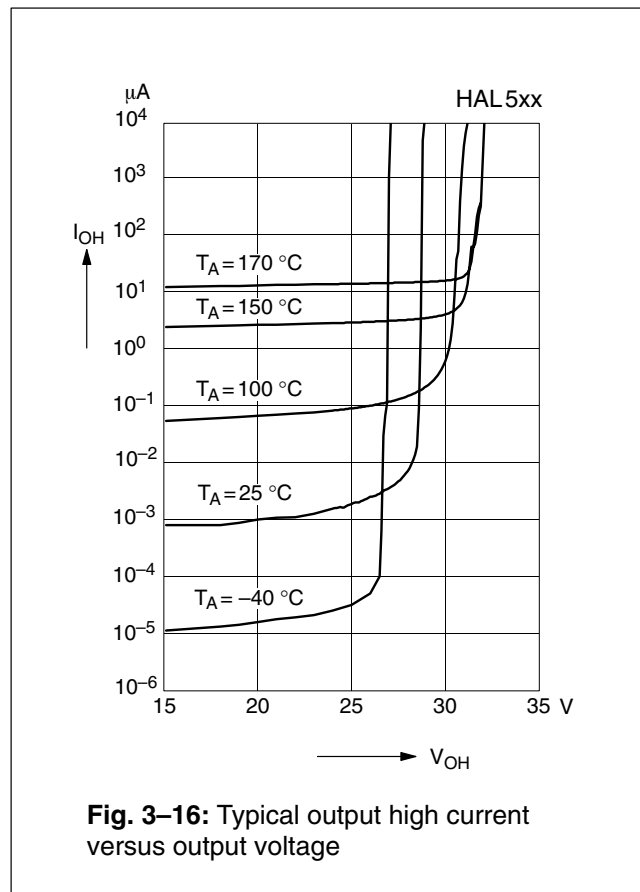
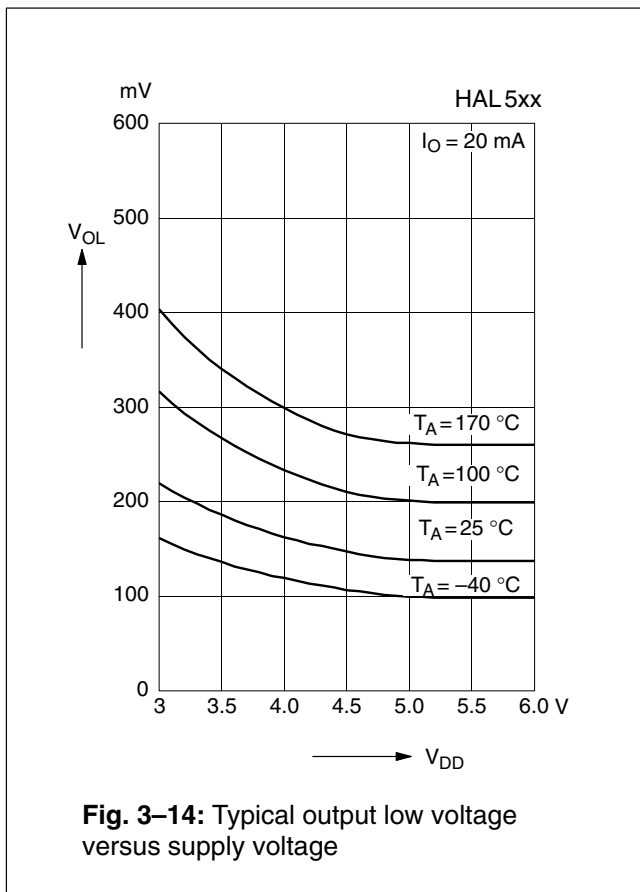
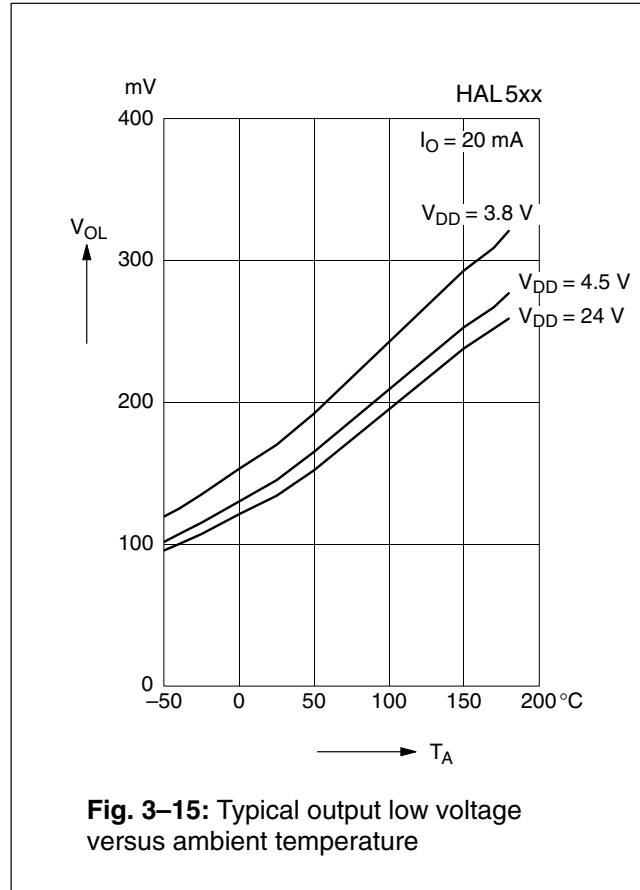
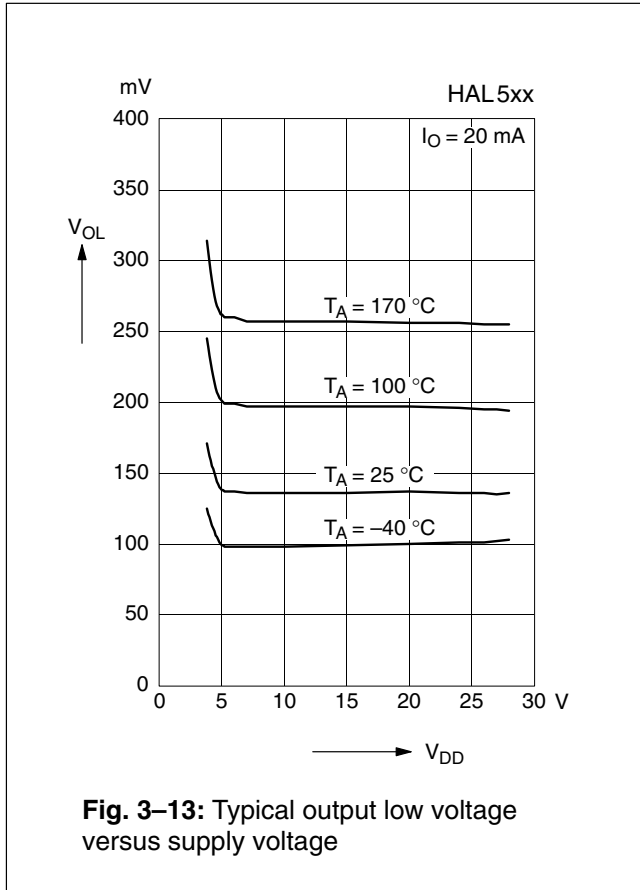

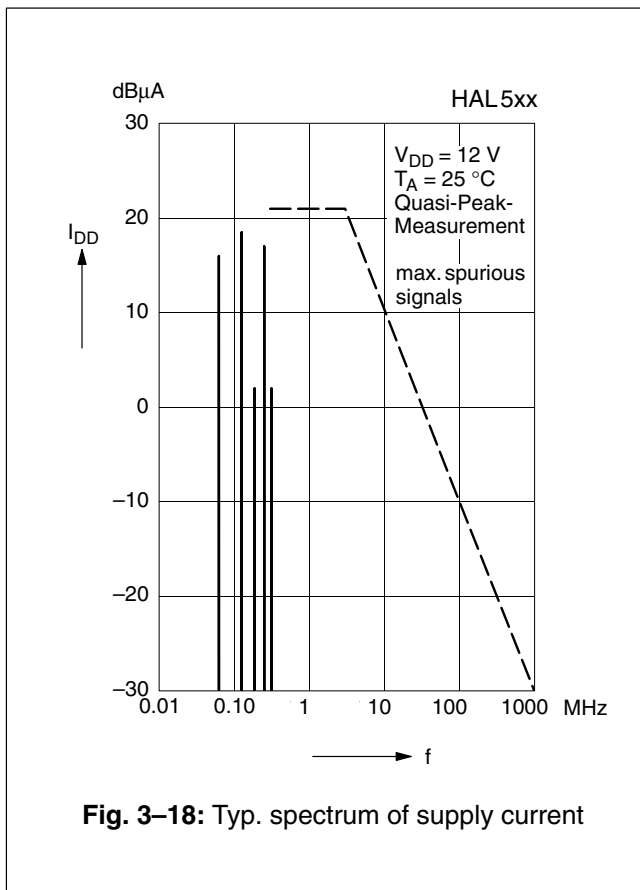
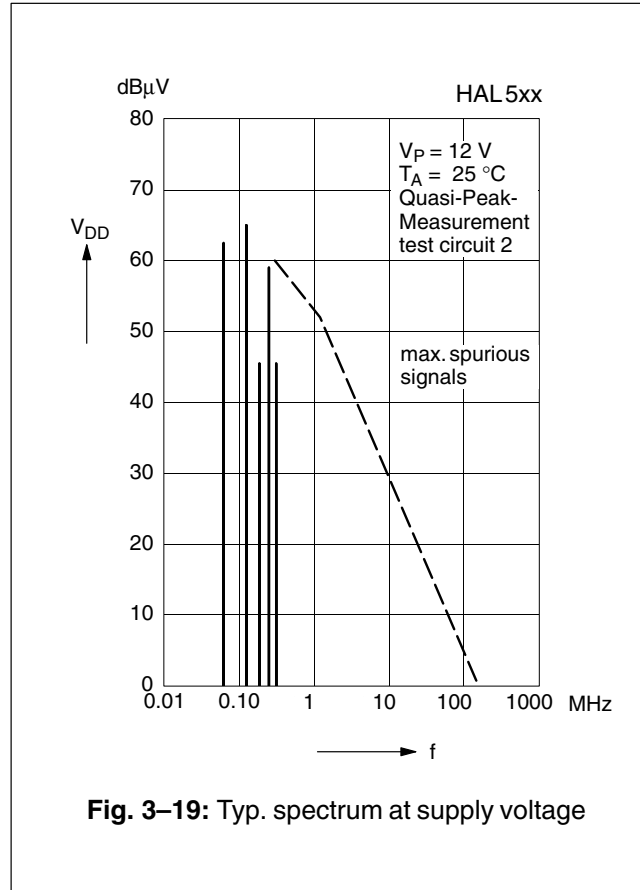
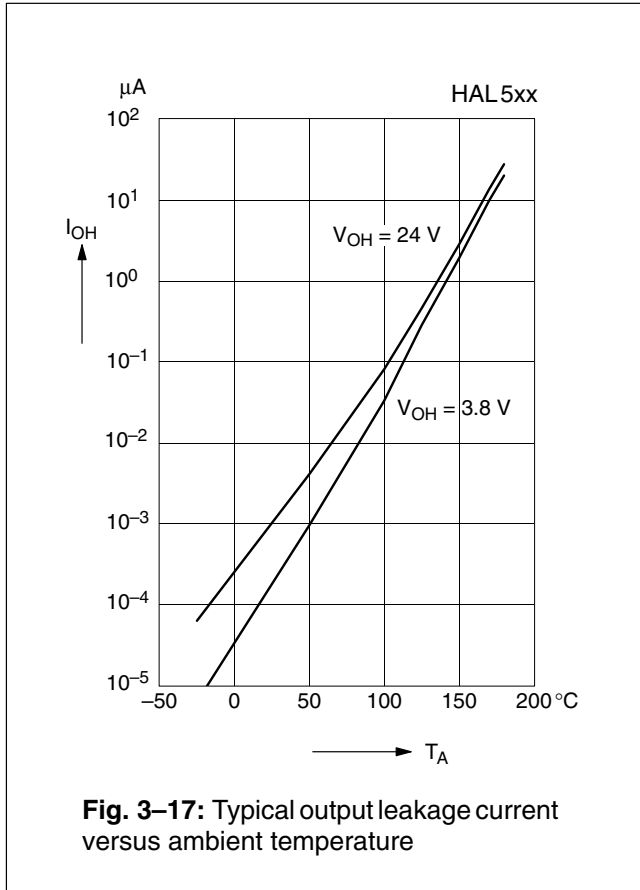

intentionally left vacant

4. Type Descriptions

4.1. HAL501

The HAL501 is the most sensitive sensor of this family with bipolar switching behavior (see Fig. 4–1).

The output turns low with the magnetic south pole on the branded side of the package and turns high with the magnetic north pole on the branded side. The output state is not defined for all sensors if the magnetic field is removed again. Some sensors will change the output state and some sensors will not.

For correct functioning in the application, the sensor requires both magnetic polarities (north and south) on the branded side of the package.

Magnetic Features:

- switching type: bipolar
- very high sensitivity
- typical B_{ON} : 0.5 mT at room temperature
- typical B_{OFF} : –0.7 mT at room temperature
- operates with static magnetic fields and dynamic magnetic fields up to 10 kHz

Applications

The HAL501 is the optimal sensor for all applications with alternating magnetic signals and weak magnetic amplitude at the sensor position such as:

- applications with large airgap or weak magnets,
- rotating speed measurement,
- CAM shaft sensors, and
- magnetic encoders.

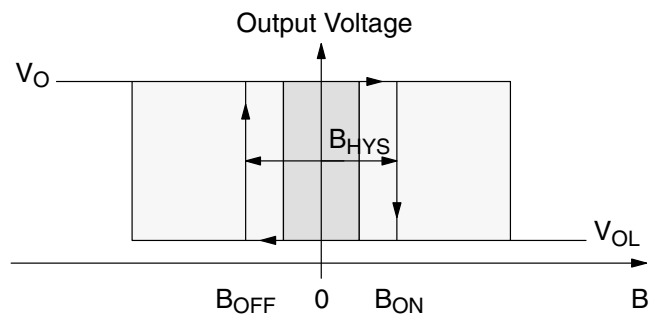

Fig. 4–1: Definition of magnetic switching points for the HAL501

Magnetic Characteristics at $T_J = -40\text{ °C}$ to $+170\text{ °C}$, $V_{DD} = 3.8\text{ V}$ to 24 V , Typical Characteristics for $V_{DD} = 12\text{ V}$

Magnetic flux density values of switching points. Positive flux density values refer to the magnetic south pole at the branded side of the package.

Parameter T_J	On point B_{ON}			Off point B_{OFF}			Hysteresis B_{HYS}			Magnetic Offset B_{OFFSET}			Unit
	Min.	Typ.	Max.	Min.	Typ.	Max.	Min.	Typ.	Max.	Min.	Typ.	Max.	
–40 °C	–0.8	0.6	2.5	–2.5	–0.8	0.8	0.5	1.4	2		–0.1		mT
25 °C	–0.5	0.5	2.3	–2.3	–0.7	0.5	0.5	1.2	1.9	–1.4	–0.1	1.4	mT
140 °C	–1.2	0.6	2.8	–2.5	–0.5	1.3	0.5	1.1	1.8	0			mT
170 °C	–1.5	0.7	3	–2.5	–0.2	2	0.4	0.9	1.8	0.2			mT

The hysteresis is the difference between the switching points $B_{HYS} = B_{ON} - B_{OFF}$
 The magnetic offset is the mean value of the switching points $B_{OFFSET} = (B_{ON} + B_{OFF}) / 2$

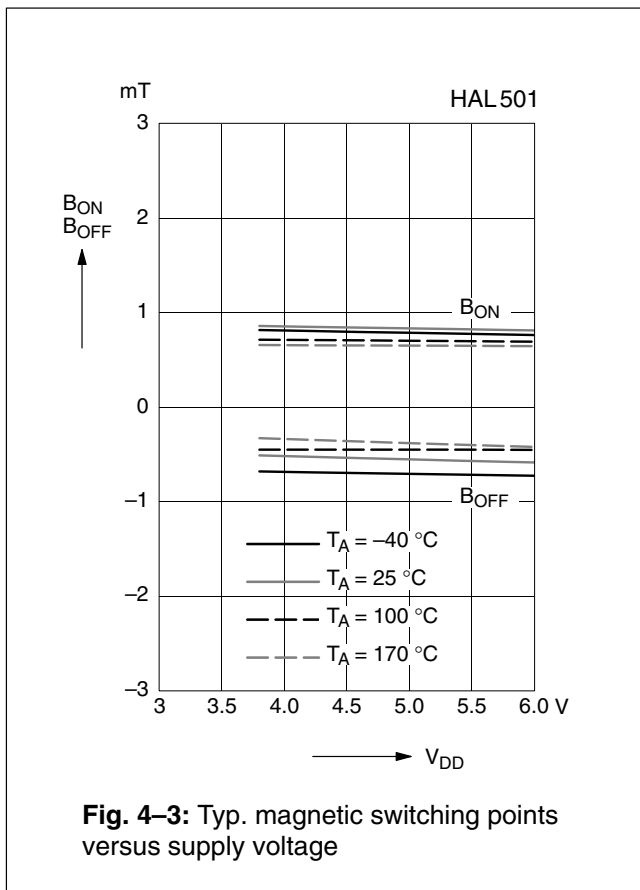
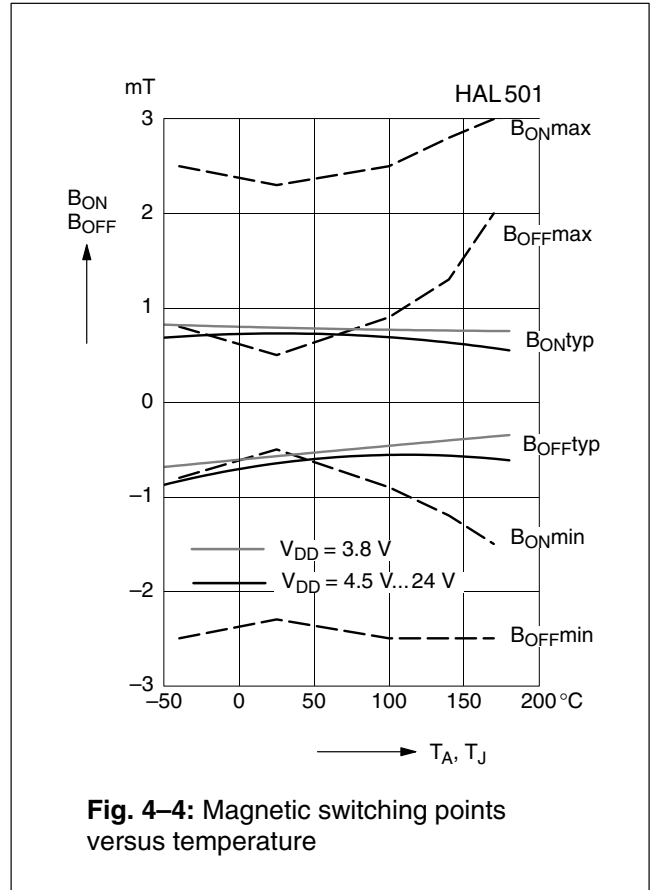
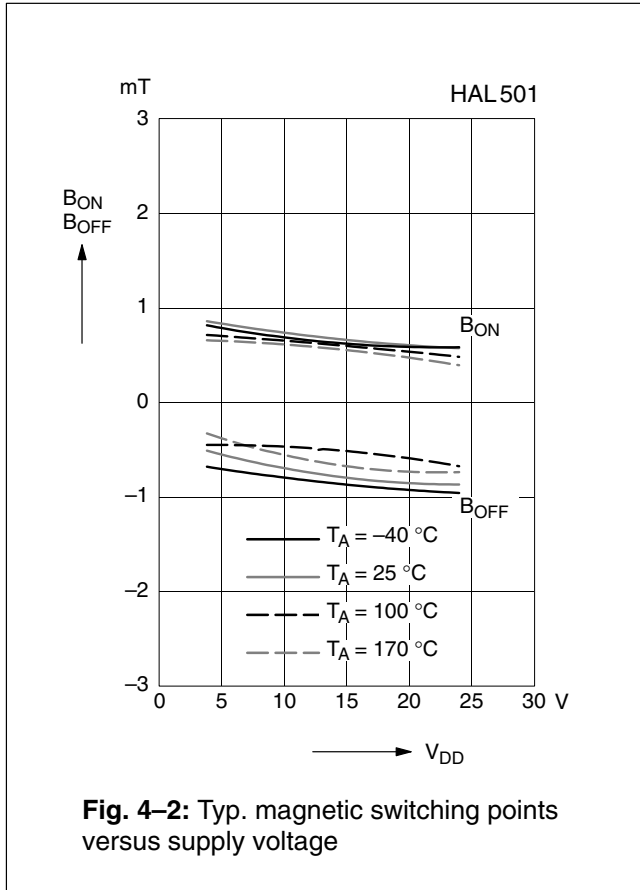

Note: In the diagram “Magnetic switching points versus temperature” the curves for B_{ONmin} , B_{ONmax} , B_{OFFmin} , and B_{OFFmax} refer to junction temperature, whereas typical curves refer to ambient temperature.

4.2. HAL502

The HAL502 is the most sensitive latching sensor of this family (see Fig. 4–5).

The output turns low with the magnetic south pole on the branded side of the package and turns high with the magnetic north pole on the branded side. The output does not change if the magnetic field is removed. For changing the output state, the opposite magnetic field polarity must be applied.

For correct functioning in the application, the sensor requires both magnetic polarities (north and south) on the branded side of the package.

Magnetic Features:

- switching type: latching
- high sensitivity
- typical B_{ON} : 2.6 mT at room temperature
- typical B_{OFF} : -2.6 mT at room temperature
- operates with static magnetic fields and dynamic magnetic fields up to 10 kHz
- typical temperature coefficient of magnetic switching points is -1000 ppm/K

Applications

The HAL502 is the optimal sensor for all applications with alternating magnetic signals and weak magnetic amplitude at the sensor position such as:

- applications with large airgap or weak magnets,
- rotating speed measurement,
- commutation of brushless DC motors,
- CAM shaft sensors, and
- magnetic encoders.

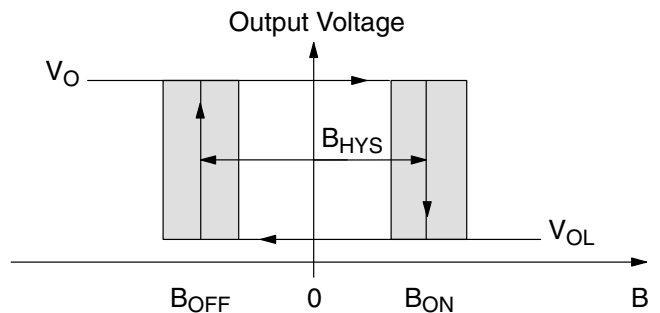

Fig. 4–5: Definition of magnetic switching points for the HAL502

Magnetic Characteristics at $T_J = -40\text{ °C}$ to $+170\text{ °C}$, $V_{DD} = 3.8\text{ V}$ to 24 V , Typical Characteristics for $V_{DD} = 12\text{ V}$

Magnetic flux density values of switching points. Positive flux density values refer to the magnetic south pole at the branded side of the package.

Parameter T_J	On point B_{ON}			Off point B_{OFF}			Hysteresis B_{HYS}			Magnetic Offset			Unit
	Min.	Typ.	Max.	Min.	Typ.	Max.	Min.	Typ.	Max.	Min.	Typ.	Max.	
-40 °C	1	2.8	5	-5	-2.8	-1	4.5	5.6	7.2		0		mT
25 °C	1	2.6	4.5	-4.5	-2.6	-1	4.5	5.2	7	-1.5	0	1.5	mT
140 °C	0.9	2.4	4.3	-4.3	-2.4	-0.9	3.7	4.8	6.8		0		mT
170 °C	0.9	2.3	4.3	-4.3	-2.3	-0.9	3.5	4.6	6.8		0		mT

The hysteresis is the difference between the switching points $B_{HYS} = B_{ON} - B_{OFF}$
 The magnetic offset is the mean value of the switching points $B_{OFFSET} = (B_{ON} + B_{OFF}) / 2$

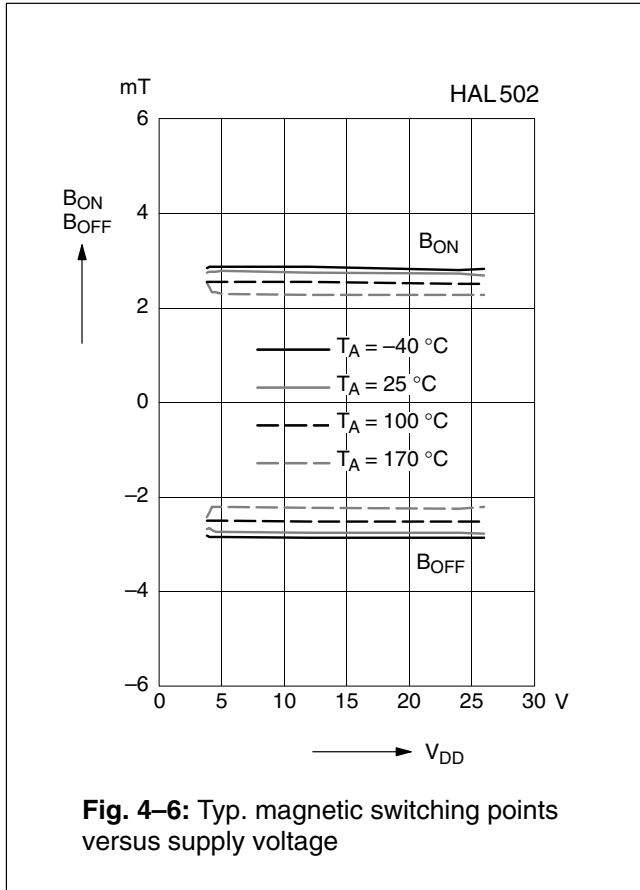

Fig. 4-6: Typ. magnetic switching points versus supply voltage

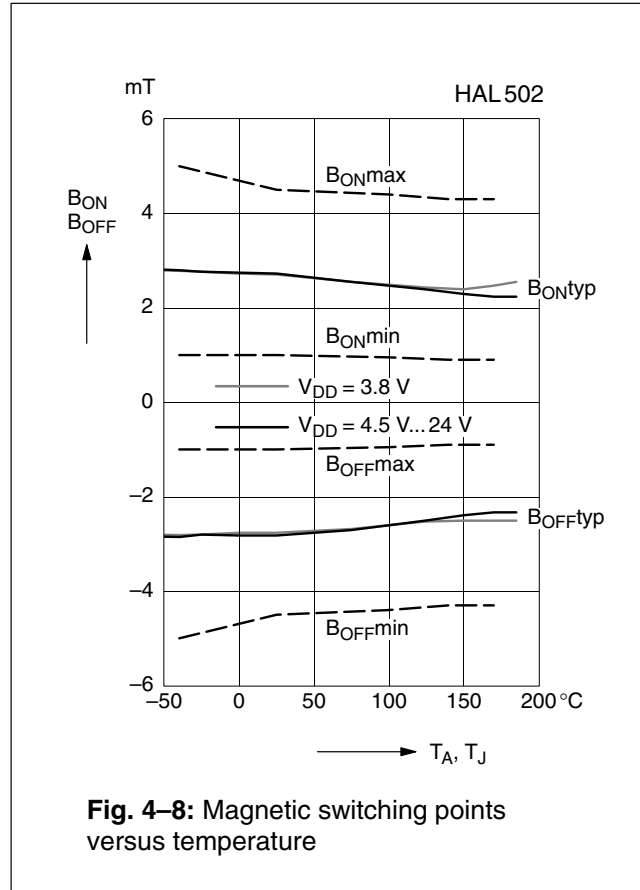

Fig. 4-8: Magnetic switching points versus temperature

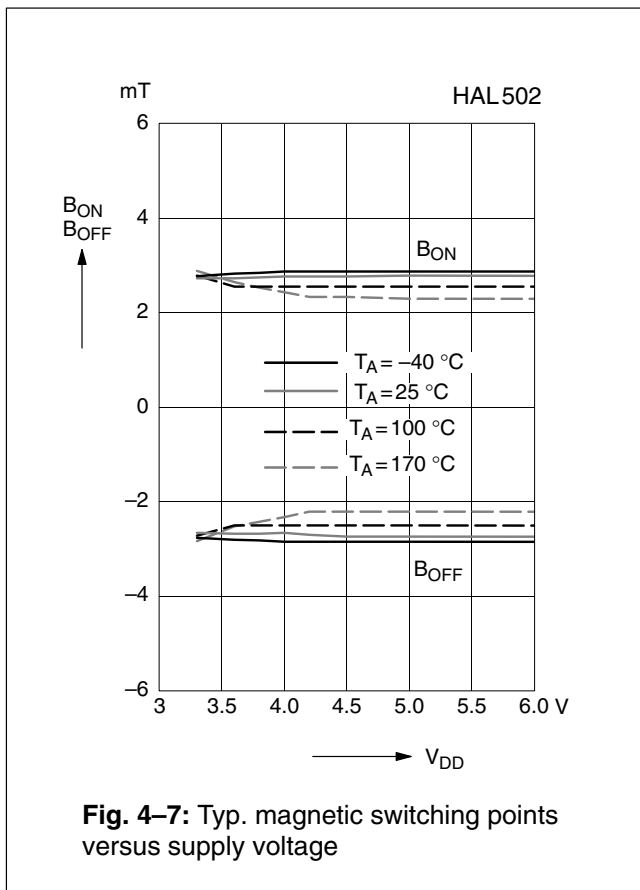

Fig. 4-7: Typ. magnetic switching points versus supply voltage

Note: In the diagram “Magnetic switching points versus temperature” the curves for B_{ONmin} , B_{ONmax} , B_{OFFmin} , and B_{OFFmax} refer to junction temperature, whereas typical curves refer to ambient temperature.

4.3. HAL503

The HAL503 is a latching sensor (see Fig. 4–9).

The output turns low with the magnetic south pole on the branded side of the package and turns high with the magnetic north pole on the branded side. The output does not change if the magnetic field is removed. For changing the output state, the opposite magnetic field polarity must be applied.

For correct functioning in the application, the sensor requires both magnetic polarities (north and south) on the branded side of the package.

Magnetic Features:

- switching type: latching
- medium sensitivity
- typical B_{ON} : 7.6 mT at room temperature
- typical B_{OFF} : -7.6 mT at room temperature
- operates with static magnetic fields and dynamic magnetic fields up to 10 kHz
- typical temperature coefficient of magnetic switching points is -1000 ppm/K

Applications

The HAL503 is the optimal sensor for applications with alternating magnetic signals such as:

- multipole magnet applications,
- rotating speed measurement,
- commutation of brushless DC motors, and
- window lifters.

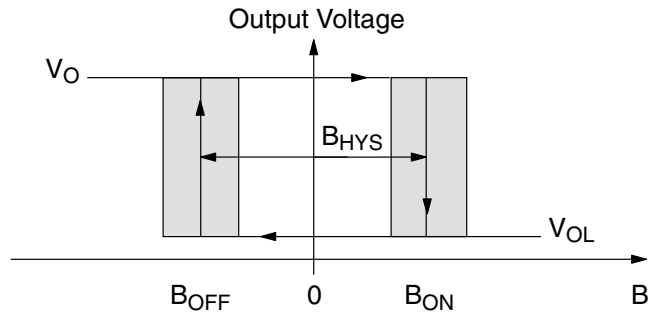

Fig. 4–9: Definition of magnetic switching points for the HAL503

Magnetic Characteristics at $T_J = -40\text{ °C}$ to $+170\text{ °C}$, $V_{DD} = 3.8\text{ V}$ to 24 V , Typical Characteristics for $V_{DD} = 12\text{ V}$

Magnetic flux density values of switching points. Positive flux density values refer to the magnetic south pole at the branded side of the package.

Parameter T_J	On point B_{ON}			Off point B_{OFF}			Hysteresis B_{HYS}			Magnetic Offset			Unit
	Min.	Typ.	Max.	Min.	Typ.	Max.	Min.	Typ.	Max.	Min.	Typ.	Max.	
-40 °C	6.4	8.4	10.8	-10.8	-8.6	-6.4	14.6	17	20.6		-0.1		mT
25 °C	6	7.6	10	-10	-7.6	-6	13.6	15.2	18	-1.5	0	1.5	mT
140 °C	4.4	6.7	9.2	-9.2	-6.4	-4.4	11.5	13.1	16.5		0.1		mT
170 °C	4	6.4	8.9	-8.9	-6	-4	11	12.4	16		0.2		mT

The hysteresis is the difference between the switching points $B_{HYS} = B_{ON} - B_{OFF}$
 The magnetic offset is the mean value of the switching points $B_{OFFSET} = (B_{ON} + B_{OFF}) / 2$

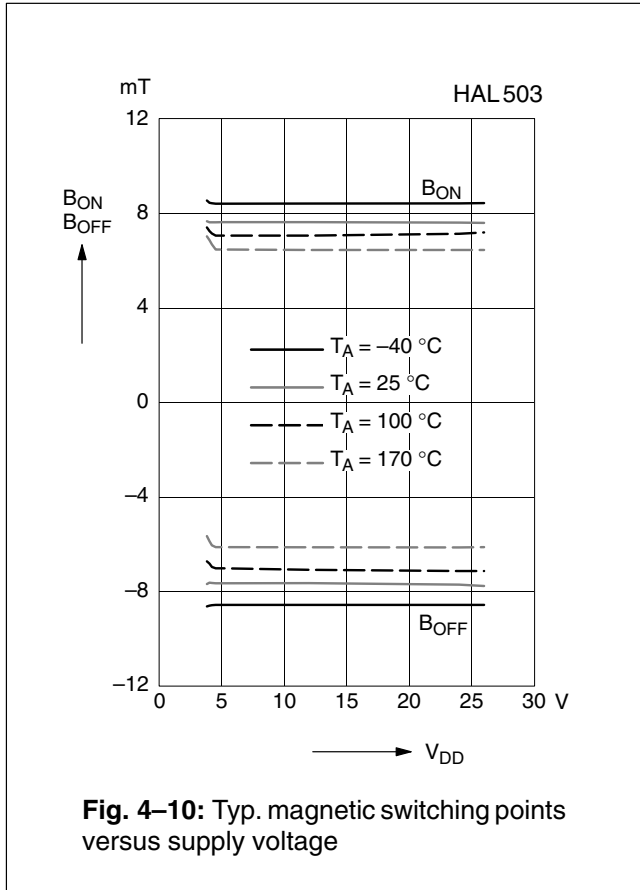

Fig. 4-10: Typ. magnetic switching points versus supply voltage

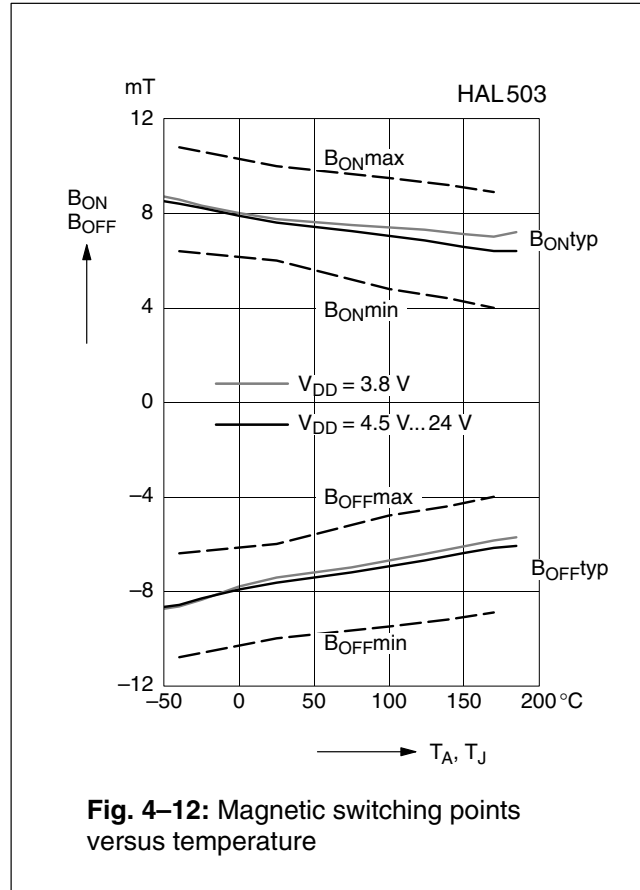

Fig. 4-12: Magnetic switching points versus temperature

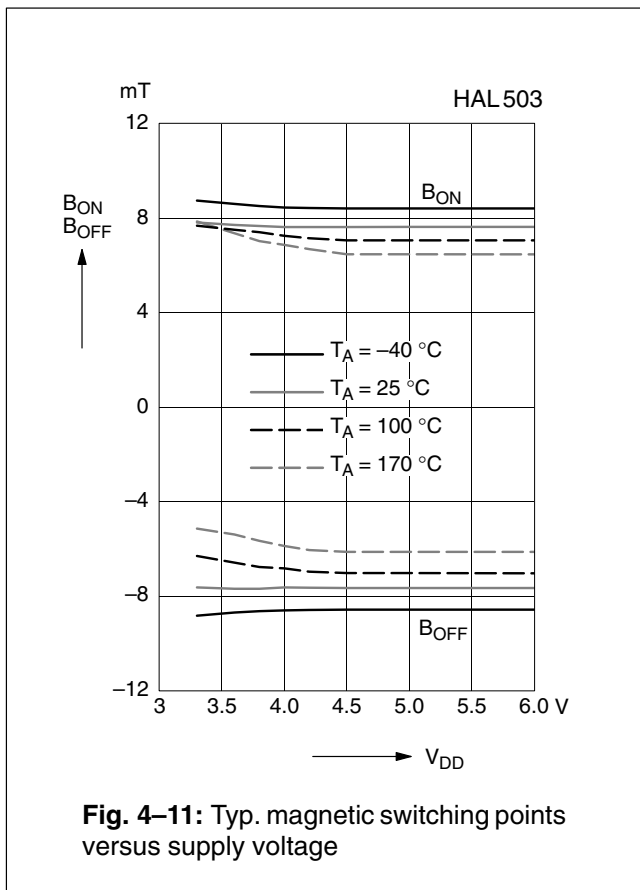

Fig. 4-11: Typ. magnetic switching points versus supply voltage

Note: In the diagram “Magnetic switching points versus ambient temperature” the curves for B_{ONmin} , B_{ONmax} , B_{OFFmin} , and B_{OFFmax} refer to junction temperature, whereas typical curves refer to ambient temperature.

4.4. HAL504

The HAL504 is a unipolar switching sensor (see Fig. 4–13).

The output turns low with the magnetic south pole on the branded side of the package and turns high if the magnetic field is removed. The sensor does not respond to the magnetic north pole on the branded side.

For correct functioning in the application, the sensor requires only the magnetic south pole on the branded side of the package.

Magnetic Features:

- switching type: unipolar
- medium sensitivity
- typical B_{ON} : 12 mT at room temperature
- typical B_{OFF} : 7 mT at room temperature
- operates with static magnetic fields and dynamic magnetic fields up to 10 kHz
- typical temperature coefficient of magnetic switching points is -1000 ppm/K

Applications

The HAL504 is the optimal sensor for applications with one magnetic polarity such as:

- solid state switches,
- contactless solution to replace micro switches,
- position and end-point detection, and
- rotating speed measurement.

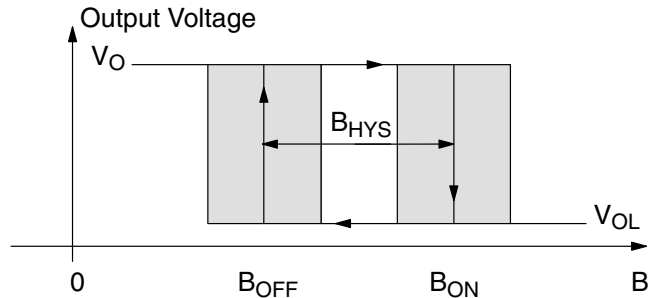

Fig. 4–13: Definition of magnetic switching points for the HAL504

Magnetic Characteristics at $T_J = -40$ °C to $+170$ °C, $V_{DD} = 3.8$ V to 24 V, Typical Characteristics for $V_{DD} = 12$ V

Magnetic flux density values of switching points. Positive flux density values refer to the magnetic south pole at the branded side of the package.

Parameter T_J	On point B_{ON}			Off point B_{OFF}			Hysteresis B_{HYS}			Magnetic Offset			Unit
	Min.	Typ.	Max.	Min.	Typ.	Max.	Min.	Typ.	Max.	Min.	Typ.	Max.	
-40 °C	10.3	13	15.7	5.3	7.5	9.6	4.4	5.5	6.5		10.2		mT
25 °C	9.5	12	14.5	5	7	9	4	5	6.5	7.2	9.5	11.8	mT
140 °C	8.7	10.6	13.9	4.4	6.1	8.6	3.4	4.5	6.4		8.4		mT
170 °C	8.5	10.2	13.7	4.2	5.9	8.5	3.2	4.3	6.4		8		mT

The hysteresis is the difference between the switching points $B_{HYS} = B_{ON} - B_{OFF}$
 The magnetic offset is the mean value of the switching points $B_{OFFSET} = (B_{ON} + B_{OFF}) / 2$

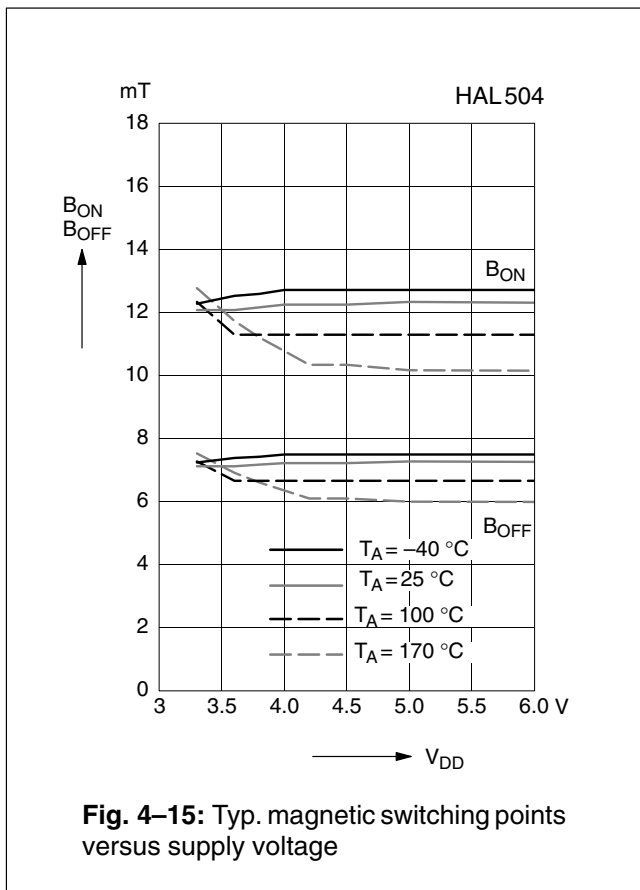
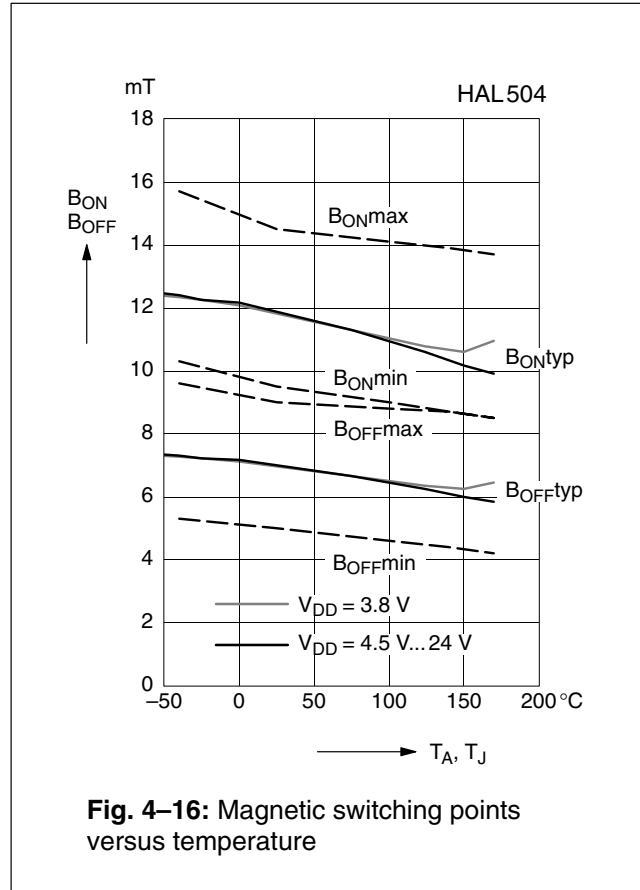
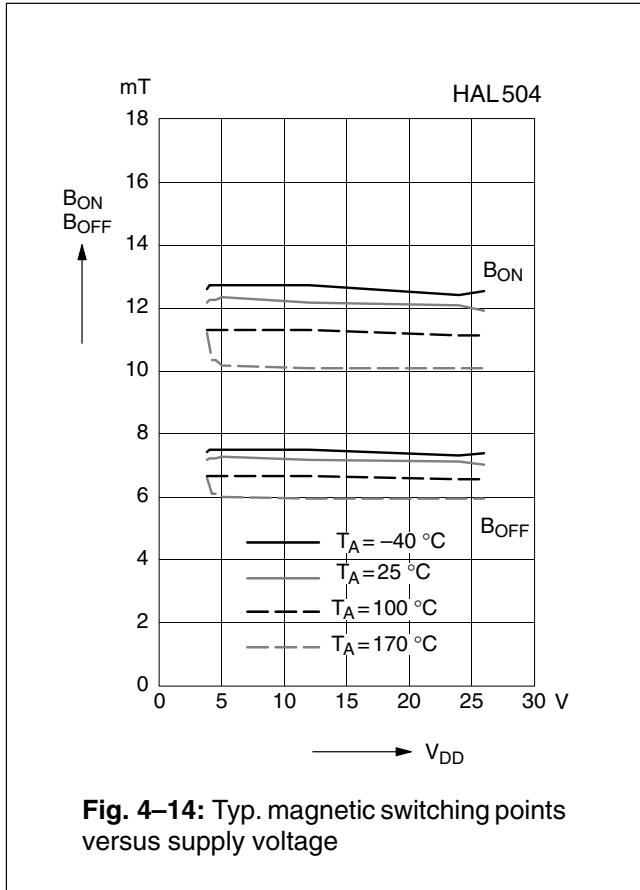

Note: In the diagram “Magnetic switching points versus temperature” the curves for B_{ONmin} , B_{ONmax} , B_{OFFmin} , and B_{OFFmax} refer to junction temperature, whereas typical curves refer to ambient temperature.

4.5. HAL505

The HAL505 is a latching sensor (see Fig. 4–17).

The output turns low with the magnetic south pole on the branded side of the package and turns high with the magnetic north pole on the branded side. The output does not change if the magnetic field is removed. For changing the output state, the opposite magnetic field polarity must be applied.

For correct functioning in the application, the sensor requires both magnetic polarities (north and south) on the branded side of the package.

Magnetic Features:

- switching type: latching
- low sensitivity
- typical B_{ON} : 13.5 mT at room temperature
- typical B_{OFF} : -13.5 mT at room temperature
- operates with static magnetic fields and dynamic magnetic fields up to 10 kHz
- typical temperature coefficient of magnetic switching points is -1000 ppm/K

Applications

The HAL505 is the optimal sensor for applications with alternating magnetic signals such as:

- multipole magnet applications,
- rotating speed measurement,
- commutation of brushless DC motors, and
- window lifters.

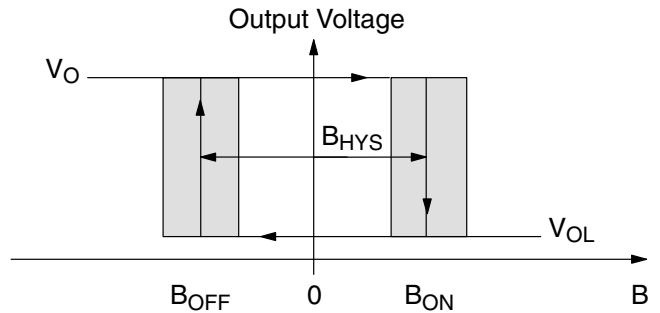

Fig. 4–17: Definition of magnetic switching points for the HAL505

Magnetic Characteristics at $T_J = -40\text{ °C}$ to $+170\text{ °C}$, $V_{DD} = 3.8\text{ V}$ to 24 V , Typical Characteristics for $V_{DD} = 12\text{ V}$

Magnetic flux density values of switching points. Positive flux density values refer to the magnetic south pole at the branded side of the package.

Parameter T_J	On point B_{ON}			Off point B_{OFF}			Hysteresis B_{HYS}			Magnetic Offset			Unit
	Min.	Typ.	Max.	Min.	Typ.	Max.	Min.	Typ.	Max.	Min.	Typ.	Max.	
-40 °C	11.8	15	18.3	-18.3	-15	-11.8	26	30	34		0		mT
25 °C	11	13.5	17	-17	-13.5	-11	24	27	32	-1.5	0	1.5	mT
140 °C	9.7	12	16.3	-16.3	-12	-9.7	21	24.2	31.3		0		mT
170 °C	9.4	11.7	16.1	-16.1	-11.7	-9.4	20	23.4	31.3		0		mT

The hysteresis is the difference between the switching points $B_{HYS} = B_{ON} - B_{OFF}$
 The magnetic offset is the mean value of the switching points $B_{OFFSET} = (B_{ON} + B_{OFF}) / 2$

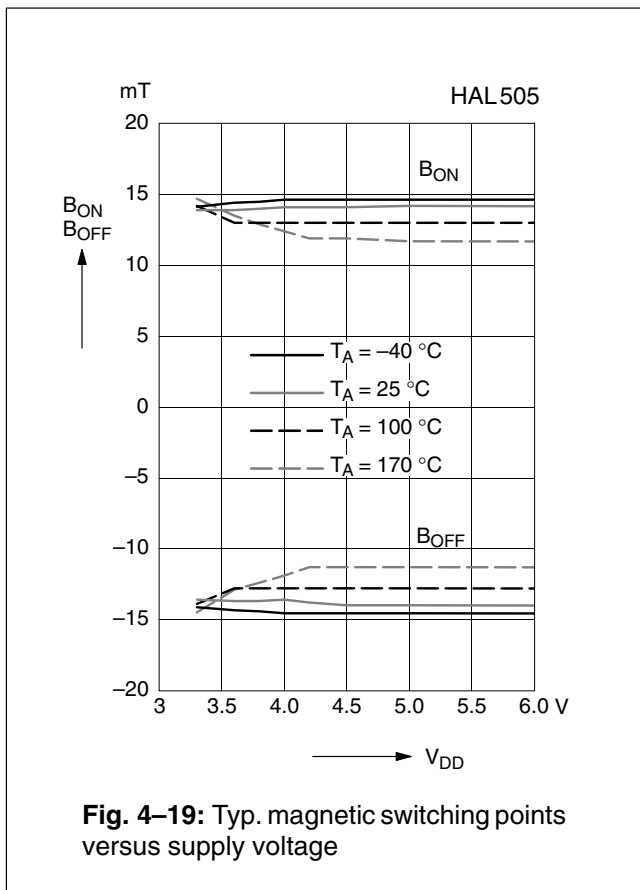
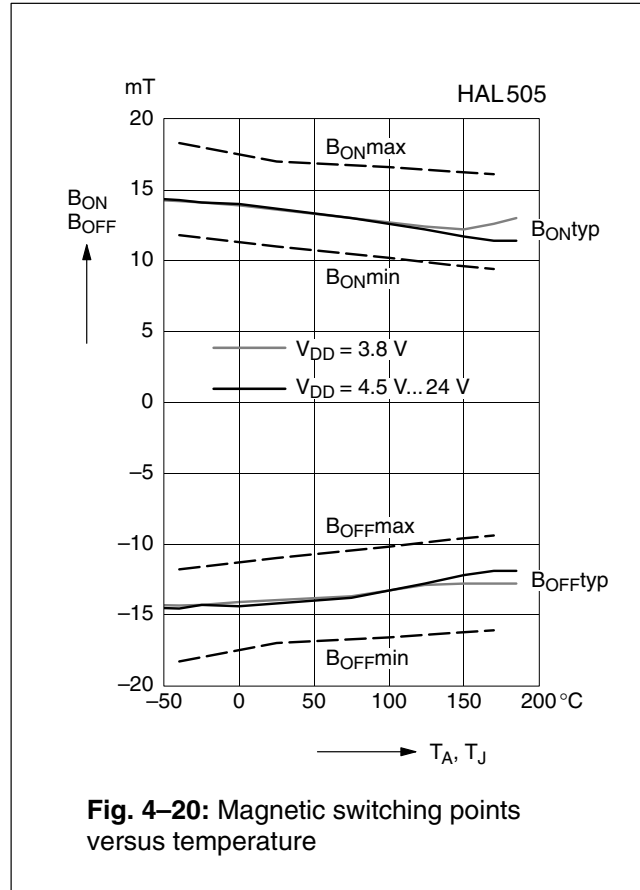
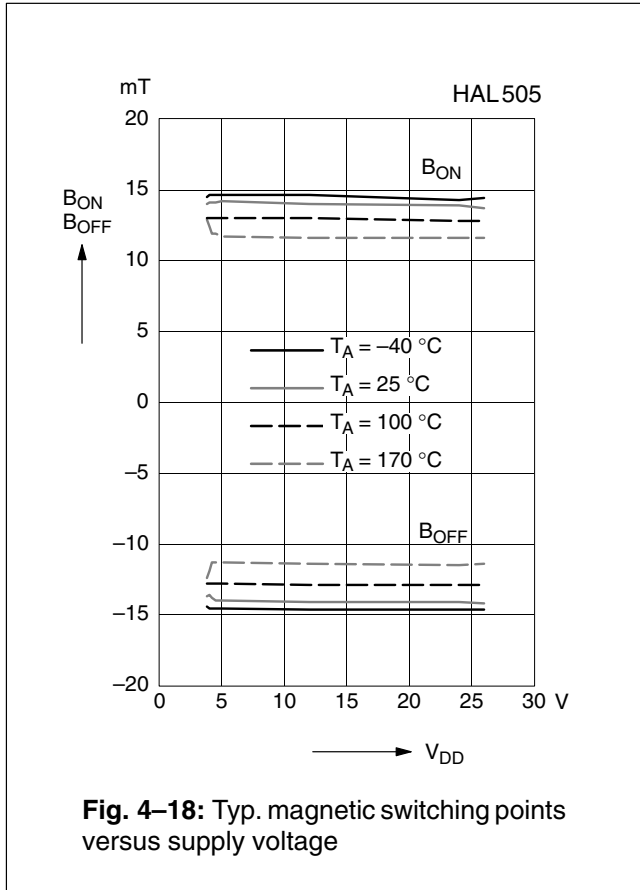

Note: In the diagram “Magnetic switching points versus ambient temperature” the curves for B_{ONmin} , B_{ONmax} , B_{OFFmin} , and B_{OFFmax} refer to junction temperature, whereas typical curves refer to ambient temperature.

4.6. HAL506

The HAL506 is the most sensitive unipolar switching sensor of this family (see Fig. 4–21).

The output turns low with the magnetic south pole on the branded side of the package and turns high if the magnetic field is removed. The sensor does not respond to the magnetic north pole on the branded side.

For correct functioning in the application, the sensor requires only the magnetic south pole on the branded side of the package.

In the HAL5xx family, the HAL516 is a sensor with the same magnetic characteristics but with an inverted output characteristic.

Magnetic Features:

- switching type: unipolar
- high sensitivity
- typical B_{ON} : 5.5 mT at room temperature
- typical B_{OFF} : 3.5 mT at room temperature
- operates with static magnetic fields and dynamic magnetic fields up to 10 kHz
- typical temperature coefficient of magnetic switching points is -1000 ppm/K

Applications

The HAL506 is the optimal sensor for all applications with one magnetic polarity and weak magnetic amplitude at the sensor position such as:

- applications with large airgap or weak magnets,
- solid state switches,
- contactless solution to replace micro switches,
- position and end point detection, and
- rotating speed measurement.

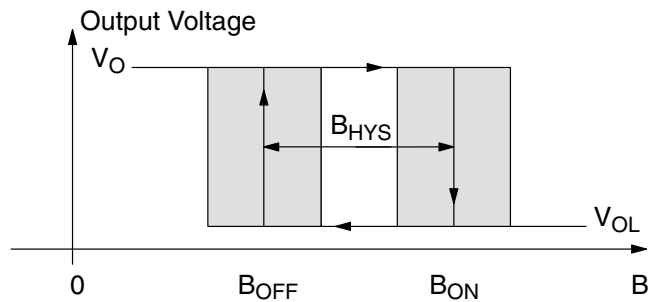

Fig. 4–21: Definition of magnetic switching points for the HAL506

Magnetic Characteristics at $T_J = -40\text{ °C}$ to $+170\text{ °C}$, $V_{DD} = 3.8\text{ V}$ to 24 V , Typical Characteristics for $V_{DD} = 12\text{ V}$

Magnetic flux density values of switching points.

Positive flux density values refer to the magnetic south pole at the branded side of the package.

Parameter T_J	On point B_{ON}			Off point B_{OFF}			Hysteresis B_{HYS}			Magnetic Offset			Unit
	Min.	Typ.	Max.	Min.	Typ.	Max.	Min.	Typ.	Max.	Min.	Typ.	Max.	
-40 °C	4.3	5.9	7.7	2.1	3.8	5.4	1.6	2.1	2.8		4.8		mT
25 °C	3.8	5.5	7.2	2	3.5	5	1.5	2	2.7	3.8	4.5	6.2	mT
140 °C	3.4	4.8	6.9	1.8	3.1	5.1	1	1.7	2.6		4		mT
170 °C	3.2	4.6	6.8	1.7	3	5.2	0.9	1.6	2.6		3.8		mT

The hysteresis is the difference between the switching points $B_{HYS} = B_{ON} - B_{OFF}$

The magnetic offset is the mean value of the switching points $B_{OFFSET} = (B_{ON} + B_{OFF}) / 2$

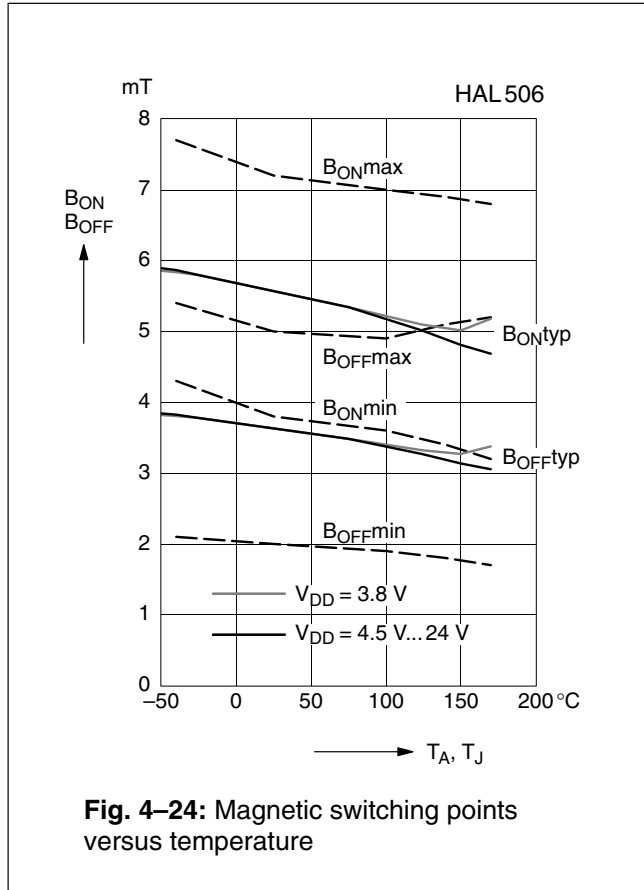
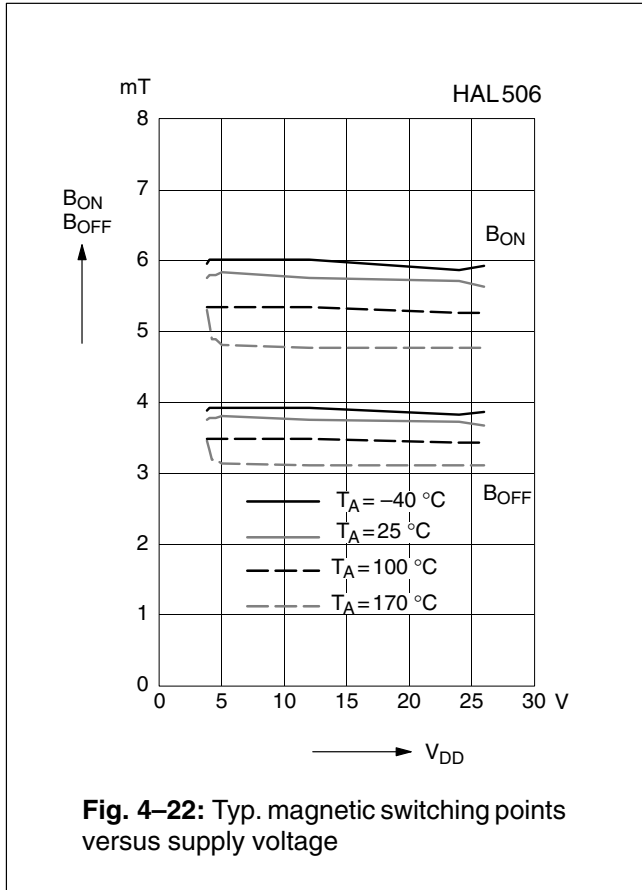

Note: In the diagram “Magnetic switching points versus temperature” the curves for B_{ONmin} , B_{ONmax} , B_{OFFmin} , and B_{OFFmax} refer to junction temperature, whereas typical curves refer to ambient temperature.

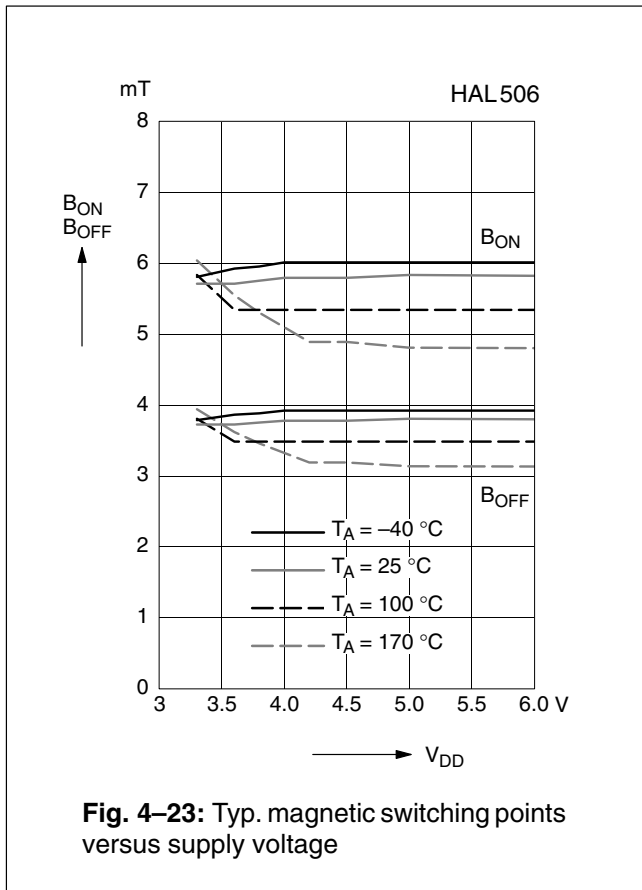

4.7. HAL508

The HAL508 is a unipolar switching sensor (see Fig. 4–25).

The output turns low with the magnetic south pole on the branded side of the package and turns high if the magnetic field is removed. The sensor does not respond to the magnetic north pole on the branded side.

For correct functioning in the application, the sensor requires only the magnetic south pole on the branded side of the package.

In the HAL5xx family, the HAL518 is a sensor with the same magnetic characteristics but with an inverted output characteristic.

Magnetic Features:

- switching type: unipolar
- medium sensitivity
- typical B_{ON} : 18 mT at room temperature
- typical B_{OFF} : 16 mT at room temperature
- operates with static magnetic fields and dynamic magnetic fields up to 10 kHz
- typical temperature coefficient of magnetic switching points is -1000 ppm/K

Applications

The HAL508 is the optimal sensor for applications with one magnetic polarity such as:

- solid state switches,
- contactless solution to replace micro switches,
- position and end point detection, and
- rotating speed measurement.

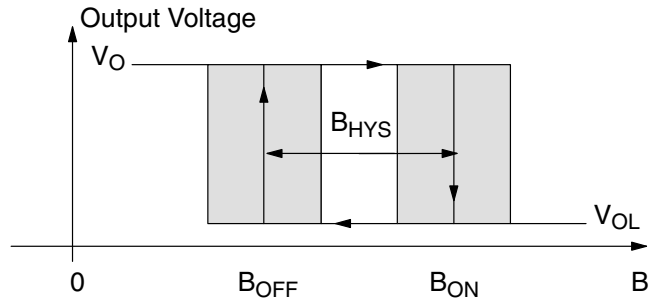

Fig. 4–25: Definition of magnetic switching points for the HAL508

Magnetic Characteristics at $T_J = -40\text{ }^\circ\text{C}$ to $+170\text{ }^\circ\text{C}$, $V_{DD} = 3.8\text{ V}$ to 24 V , Typical Characteristics for $V_{DD} = 12\text{ V}$

Magnetic flux density values of switching points.

Positive flux density values refer to the magnetic south pole at the branded side of the package.

Parameter T_J	On point B_{ON}			Off point B_{OFF}			Hysteresis B_{HYS}			Magnetic Offset			Unit
	Min.	Typ.	Max.	Min.	Typ.	Max.	Min.	Typ.	Max.	Min.	Typ.	Max.	
$-40\text{ }^\circ\text{C}$	15.5	19	21.9	14	16.7	20	1.6	2.3	2.8		17.8		mT
$25\text{ }^\circ\text{C}$	15	18	20.7	13.5	16	19	1.5	2	2.7	14	17	20	mT
$140\text{ }^\circ\text{C}$	13.2	15.8	20.2	11.9	14.1	18.5	1.1	1.7	2.6		15		mT
$170\text{ }^\circ\text{C}$	12.7	15.3	20	11.4	13.6	18.3	1	1.7	2.6		14.4		mT

The hysteresis is the difference between the switching points $B_{HYS} = B_{ON} - B_{OFF}$

The magnetic offset is the mean value of the switching points $B_{OFFSET} = (B_{ON} + B_{OFF}) / 2$

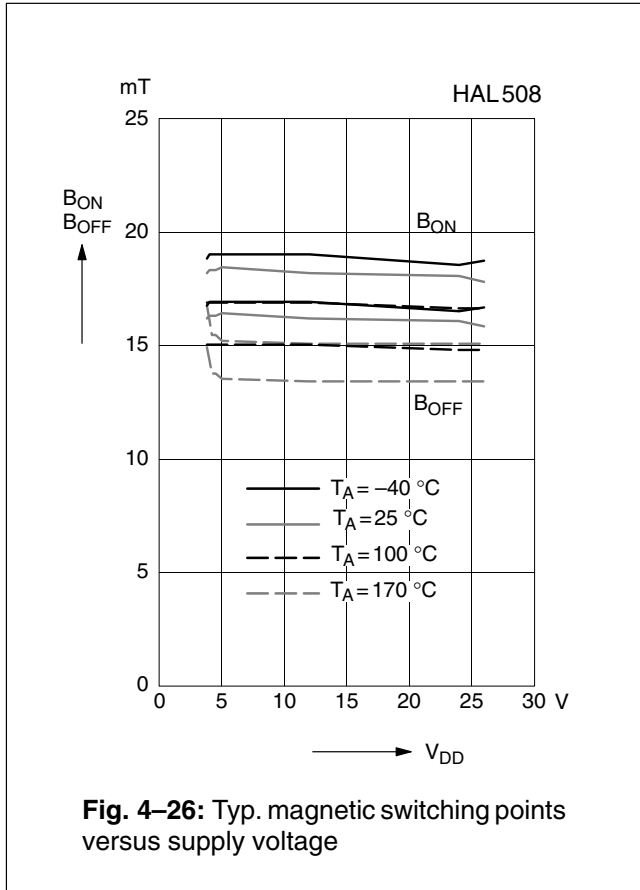

Fig. 4-26: Typ. magnetic switching points versus supply voltage

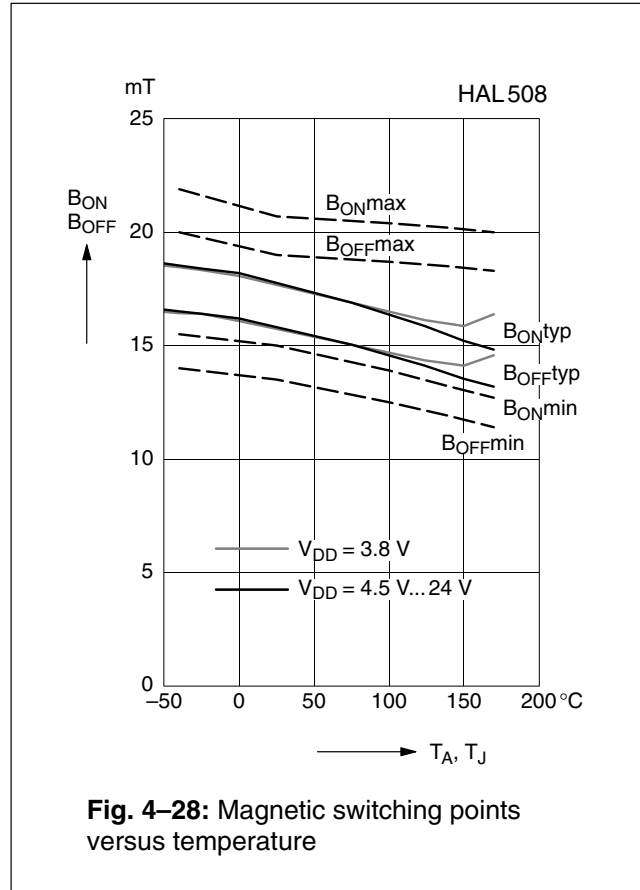

Fig. 4-28: Magnetic switching points versus temperature

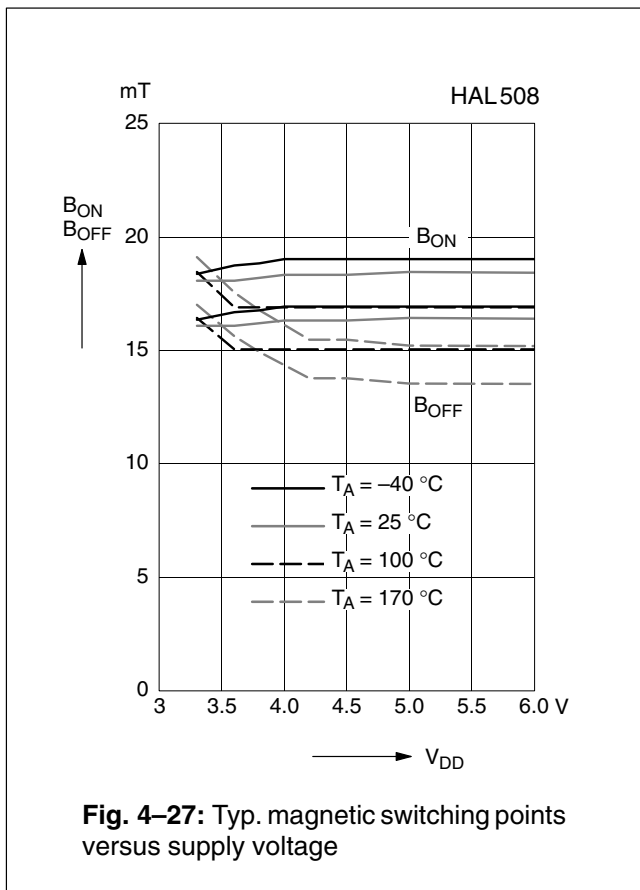

Fig. 4-27: Typ. magnetic switching points versus supply voltage

Note: In the diagram “Magnetic switching points versus temperature” the curves for B_{ONmin} , B_{ONmax} , B_{OFFmin} , and B_{OFFmax} refer to junction temperature, whereas typical curves refer to ambient temperature.

4.8. HAL509

The HAL509 is a unipolar switching sensor (see Fig. 4–29).

The output turns low with the magnetic south pole on the branded side of the package and turns high if the magnetic field is removed. The sensor does not respond to the magnetic north pole on the branded side.

For correct functioning in the application, the sensor requires only the magnetic south pole on the branded side of the package.

Magnetic Features:

- switching type: unipolar
- low sensitivity
- typical B_{ON} : 26.8 mT at room temperature
- typical B_{OFF} : 23.2 mT at room temperature
- operates with static magnetic fields and dynamic magnetic fields up to 10 kHz
- typical temperature coefficient of magnetic switching points is -300 ppm/K

Applications

The HAL509 is the optimal sensor for applications with one magnetic polarity and strong magnetic fields at the sensor position such as:

- solid state switches,
- contactless solution to replace micro switches,
- position and end point detection, and
- rotating speed measurement.

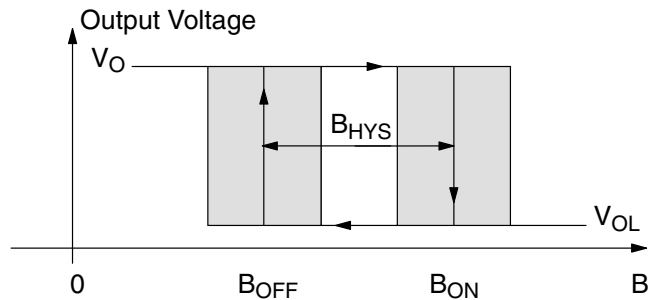

Fig. 4–29: Definition of magnetic switching points for the HAL509

Magnetic Characteristics at $T_J = -40$ °C to $+170$ °C, $V_{DD} = 3.8$ V to 24 V, Typical Characteristics for $V_{DD} = 12$ V

Magnetic flux density values of switching points. Positive flux density values refer to the magnetic south pole at the branded side of the package.

Parameter T_J	On point B_{ON}			Off point B_{OFF}			Hysteresis B_{HYS}			Magnetic Offset			Unit
	Min.	Typ.	Max.	Min.	Typ.	Max.	Min.	Typ.	Max.	Min.	Typ.	Max.	
-40 °C	23.1	27.4	31.1	19.9	23.8	27.2	2.9	3.6	3.9		25.6		mT
25 °C	23.1	26.8	30.4	19.9	23.2	26.6	2.8	3.5	3.9	21.5	25	28.5	mT
140 °C	21.7	25.7	29.2	18.6	22.4	25.6	2.6	3.3	3.8		24		mT
170 °C	21.3	25.4	28.9	18.3	22.1	25.3	2.5	3.3	3.8		23.7		mT

The hysteresis is the difference between the switching points $B_{HYS} = B_{ON} - B_{OFF}$
 The magnetic offset is the mean value of the switching points $B_{OFFSET} = (B_{ON} + B_{OFF}) / 2$

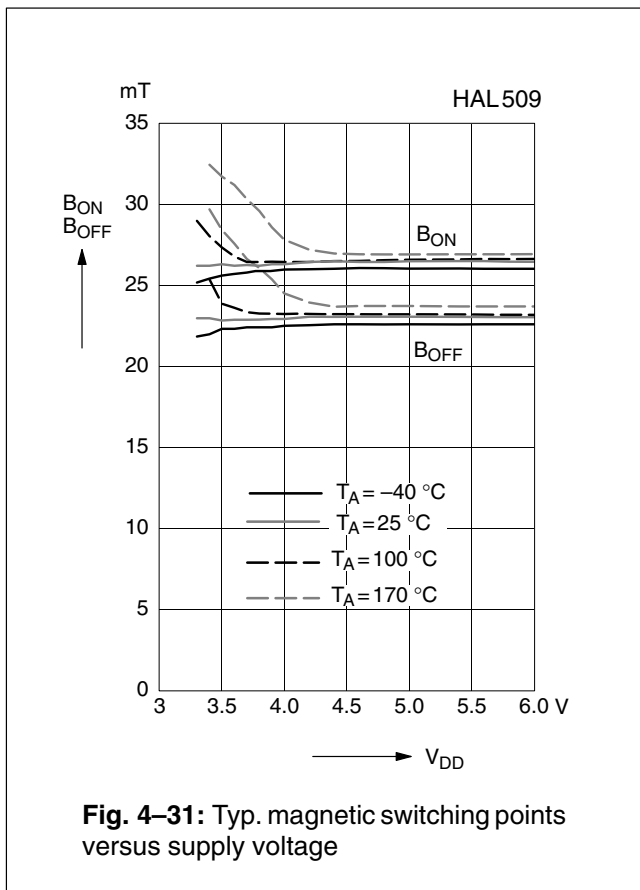
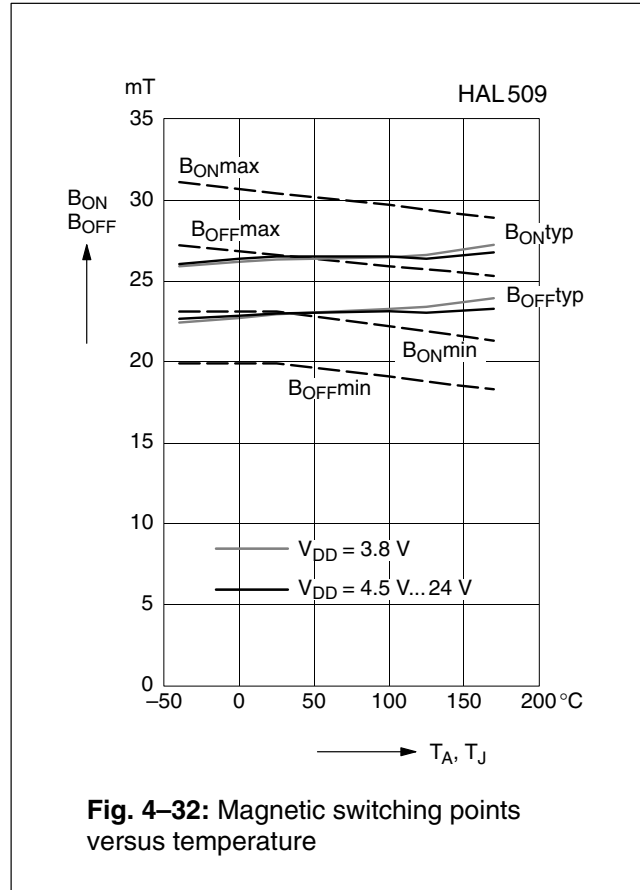
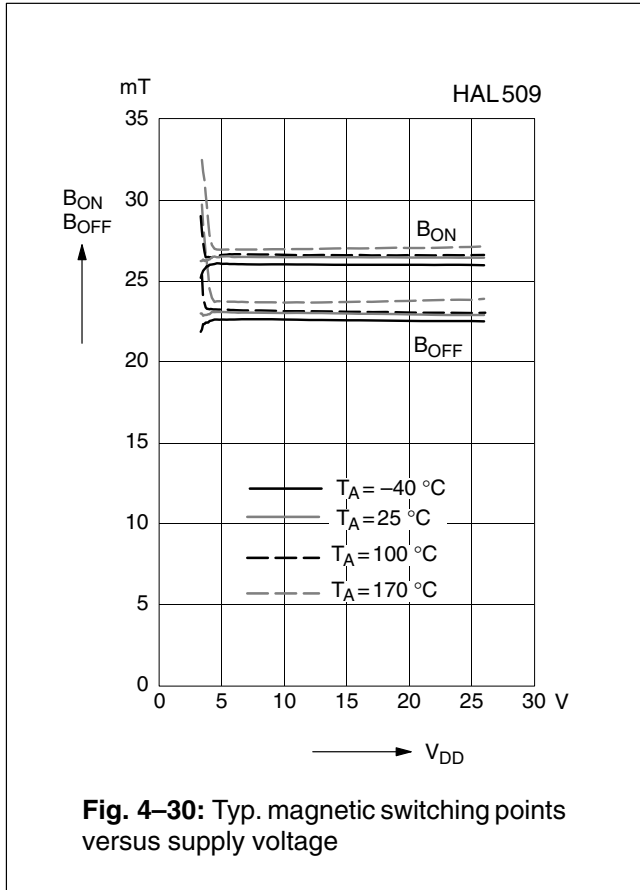

Note: In the diagram “Magnetic switching points versus temperature” the curves for B_{ONmin} , B_{ONmax} , B_{OFFmin} , and B_{OFFmax} refer to junction temperature, whereas typical curves refer to ambient temperature.

4.9. HAL516

The HAL516 is the most sensitive unipolar switching sensor with an inverted output of this family (see Fig. 4–33).

The output turns high with the magnetic south pole on the branded side of the package and turns low if the magnetic field is removed. The sensor does not respond to the magnetic north pole on the branded side.

For correct functioning in the application, the sensor requires only the magnetic south pole on the branded side of the package.

In the HAL5xx family, the HAL506 is a sensor with the same magnetic characteristics but with a normal output characteristic.

Magnetic Features:

- switching type: unipolar inverted
- high sensitivity
- typical B_{ON} : 3.5 mT at room temperature
- typical B_{OFF} : 5.5 mT at room temperature
- operates with static magnetic fields and dynamic magnetic fields up to 10 kHz
- typical temperature coefficient of magnetic switching points is -1000 ppm/K

Applications

The HAL516 is the optimal sensor for all applications with one magnetic polarity and weak magnetic amplitude at the sensor position where an inverted output signal is required such as:

- applications with large airgap or weak magnets,
- solid state switches,
- contactless solution to replace micro switches,
- position and end point detection, and
- rotating speed measurement.

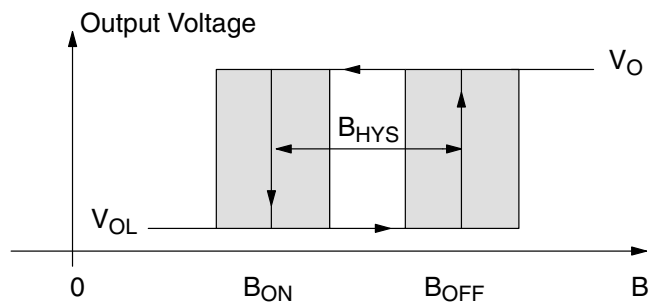

Fig. 4–33: Definition of magnetic switching points for the HAL516

Magnetic Characteristics at $T_J = -40\text{ °C}$ to $+170\text{ °C}$, $V_{DD} = 3.8\text{ V}$ to 24 V , Typical Characteristics for $V_{DD} = 12\text{ V}$

Magnetic flux density values of switching points.
Positive flux density values refer to the magnetic south pole at the branded side of the package.

Parameter T_J	On point B_{ON}			Off point B_{OFF}			Hysteresis B_{HYS}			Magnetic Offset			Unit
	Min.	Typ.	Max.	Min.	Typ.	Max.	Min.	Typ.	Max.	Min.	Typ.	Max.	
-40 °C	2.1	3.8	5.4	4.3	5.9	7.7	1.6	2.1	2.8		4.8		mT
25 °C	2	3.5	5	3.8	5.5	7.2	1.5	2	2.7	3.8	4.5	6.2	mT
140 °C	1.8	3.1	5.1	3.4	4.8	6.9	1	1.7	2.6		4		mT
170 °C	1.7	3	5.2	3.2	4.6	6.8	0.9	1.6	2.6		3.8		mT

The hysteresis is the difference between the switching points $B_{HYS} = B_{OFF} - B_{ON}$
The magnetic offset is the mean value of the switching points $B_{OFFSET} = (B_{ON} + B_{OFF}) / 2$

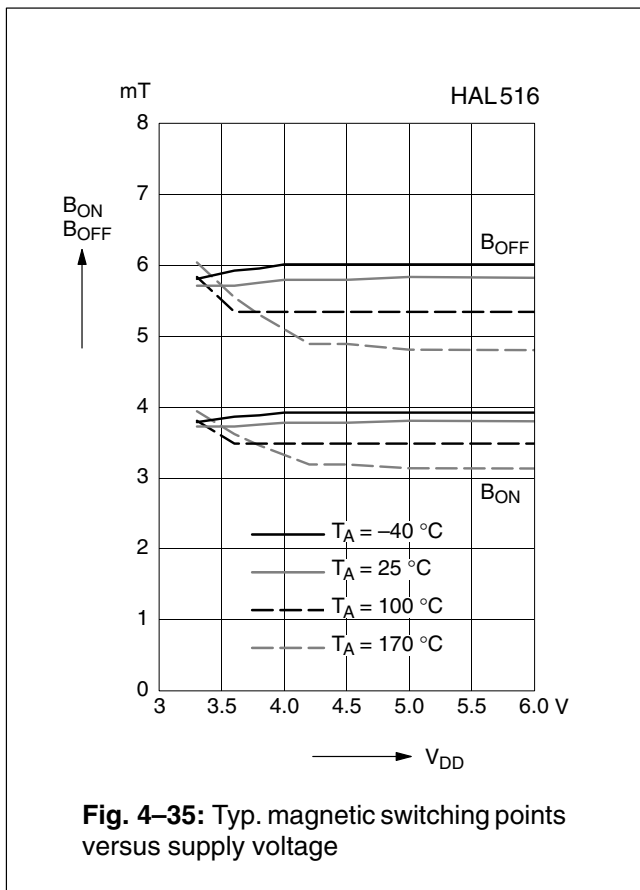
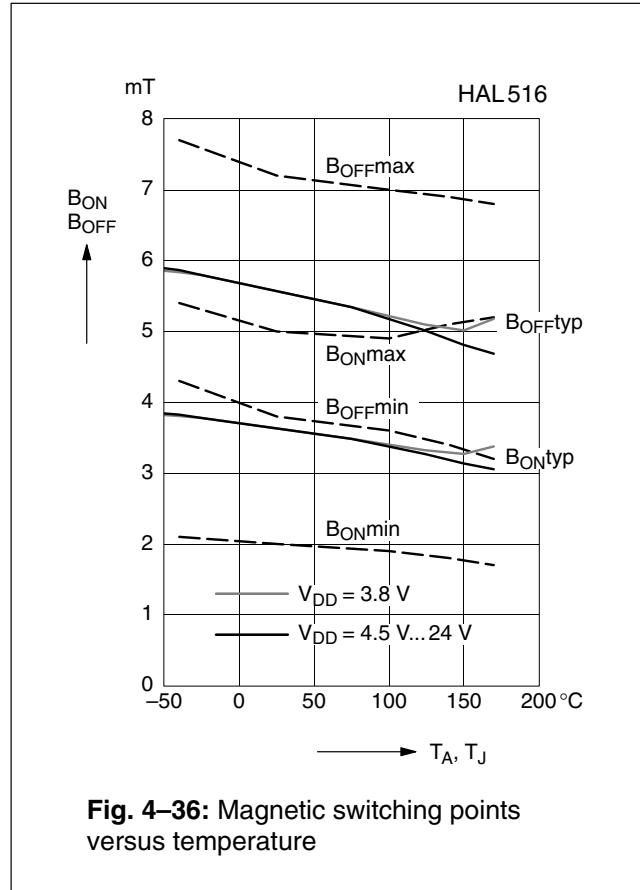
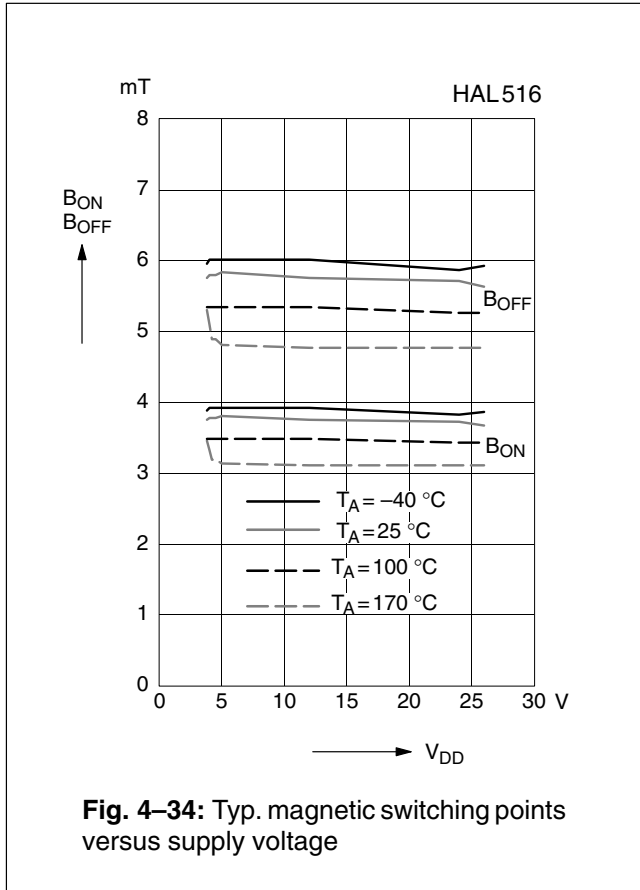

Note: In the diagram “Magnetic switching points versus temperature” the curves for B_{ONmin} , B_{ONmax} , B_{OFFmin} , and B_{OFFmax} refer to junction temperature, whereas typical curves refer to ambient temperature.

4.10. HAL517

The HAL517 is a unipolar switching sensor with inverted output (see Fig. 4–37).

The output turns high with the magnetic south pole on the branded side of the package and turns low if the magnetic field is removed. The sensor does not respond to the magnetic north pole on the branded side.

For correct functioning in the application, the sensor requires only the magnetic south pole on the branded side of the package.

Magnetic Features:

- switching type: unipolar inverted
- medium sensitivity
- typical on point is 16.2 mT at room temperature
- typical off point is 18.3 mT at room temperature
- operates with static magnetic fields and dynamic magnetic fields up to 10 kHz
- typical temperature coefficient of magnetic switching points is –1700 ppm/K

Applications

The HAL517 is the optimal sensor for applications with one magnetic polarity where an inverted output signal is required such as:

- solid state switches,
- contactless solution to replace micro switches,
- position and end point detection, and
- rotating speed measurement.

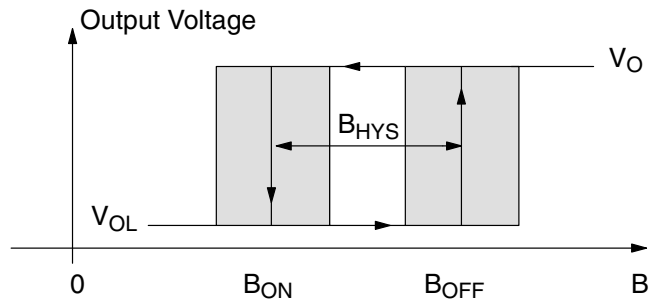

Fig. 4–37: Definition of magnetic switching points for the HAL517

Magnetic Characteristics at T_J = –40 °C to +170 °C, V_{DD} = 3.8 V to 24 V, Typical Characteristics for V_{DD} = 12 V

Magnetic flux density values of switching points. Positive flux density values refer to the magnetic south pole at the branded side of the package.

Parameter T _J	On point B _{ON}			Off point B _{OFF}			Hysteresis B _{HYS}			Magnetic Offset			Unit
	Min.	Typ.	Max.	Min.	Typ.	Max.	Min.	Typ.	Max.	Min.	Typ.	Max.	
–40 °C	14	17.1	21.5	15.5	19.6	22.5	1.6	2.5	3		18.3		mT
25 °C	13.5	16.2	19	15	18.3	20.7	1.5	2.1	2.7	14	17.2	20	mT
140 °C	10	13.2	18.2	11.5	14.8	20.2	1	1.6	2.6		14		mT
170 °C	9	12.3	18	10.5	13.7	20	0.8	1.4	2.4		13		mT

The hysteresis is the difference between the switching points $B_{HYS} = B_{OFF} - B_{ON}$
 The magnetic offset is the mean value of the switching points $B_{OFFSET} = (B_{ON} + B_{OFF}) / 2$

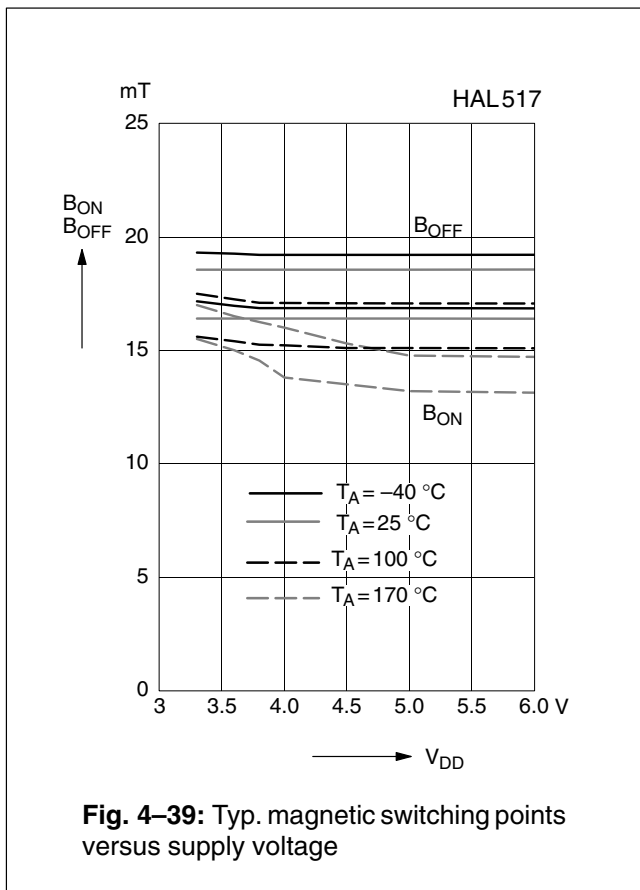
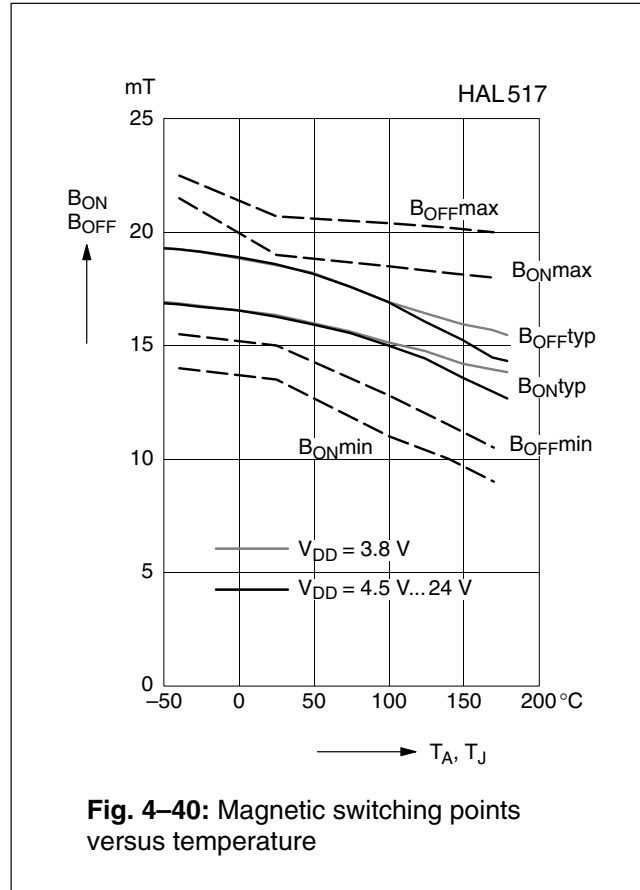
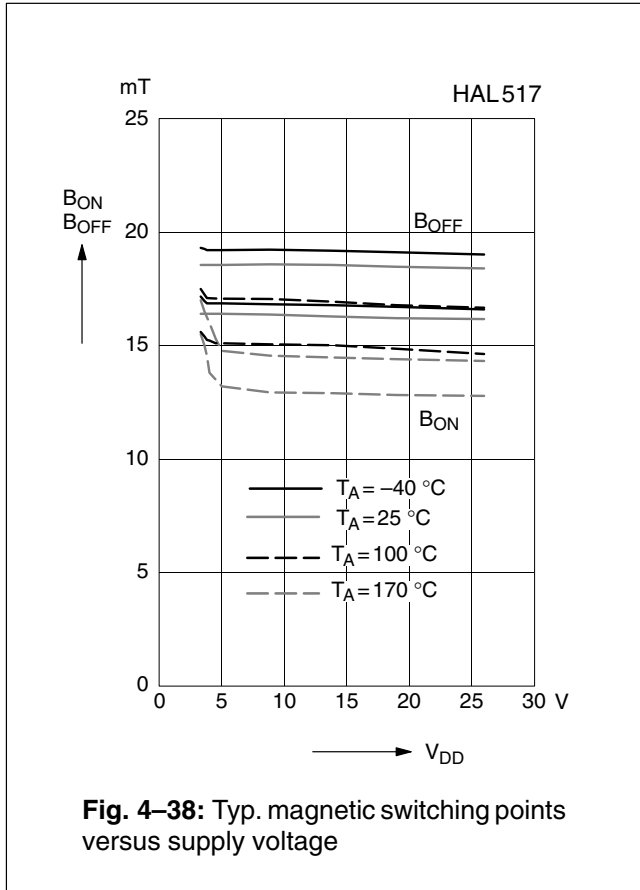

Note: In the diagram “Magnetic switching points versus ambient temperature” the curves for B_ONmin, B_ONmax, B_OFFmin, and B_OFFmax refer to junction temperature, whereas typical curves refer to ambient temperature.

4.11. HAL518

The HAL518 is a unipolar switching sensor with inverted output (see Fig. 4–41).

The output turns high with the magnetic south pole on the branded side of the package and turns low if the magnetic field is removed. The sensor does not respond to the magnetic north pole on the branded side.

For correct functioning in the application, the sensor requires only the magnetic south pole on the branded side of the package.

In the HAL5xx family, the HAL508 is a sensor with the same magnetic characteristics but with a normal output characteristic.

Magnetic Features:

- switching type: unipolar inverted
- medium sensitivity
- typical B_{ON} : 16 mT at room temperature
- typical B_{OFF} : 18 mT at room temperature
- operates with static magnetic fields and dynamic magnetic fields up to 10 kHz
- typical temperature coefficient of magnetic switching points is -1000 ppm/K

Applications

The HAL518 is the optimal sensor for applications with one magnetic polarity where an inverted output signal is required such as:

- solid state switches,
- contactless solution to replace micro switches,
- position and end point detection, and
- rotating speed measurement.

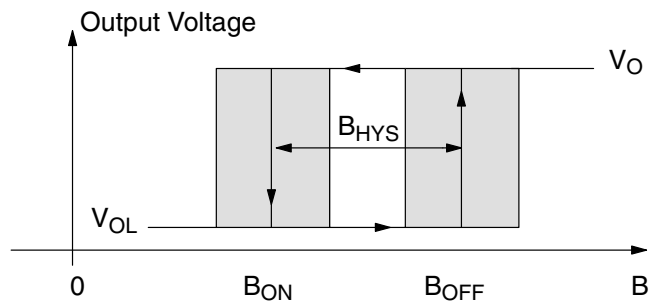

Fig. 4–41: Definition of magnetic switching points for the HAL518

Magnetic Characteristics at $T_J = -40\text{ °C}$ to $+170\text{ °C}$, $V_{DD} = 3.8\text{ V}$ to 24 V ,
Typical Characteristics for $V_{DD} = 12\text{ V}$

Magnetic flux density values of switching points.

Positive flux density values refer to the magnetic south pole at the branded side of the package.

Parameter T_J	On point B_{ON}			Off point B_{OFF}			Hysteresis B_{HYS}			Magnetic Offset			Unit
	Min.	Typ.	Max.	Min.	Typ.	Max.	Min.	Typ.	Max.	Min.	Typ.	Max.	
-40 °C	14	16.7	20	15.5	19	22	1.5	2.3	3		17.8		mT
25 °C	13.5	16	19	15	18	20.7	1.4	2	2.8	14	17	20	mT
140 °C	11.7	14.1	18.5	13	15.8	20.2	0.9	1.7	2.7		15		mT
170 °C	11	13.6	18.3	12.2	15.3	20	0.8	1.7	2.6		14.4		mT

The hysteresis is the difference between the switching points $B_{HYS} = B_{OFF} - B_{ON}$

The magnetic offset is the mean value of the switching points $B_{OFFSET} = (B_{ON} + B_{OFF}) / 2$

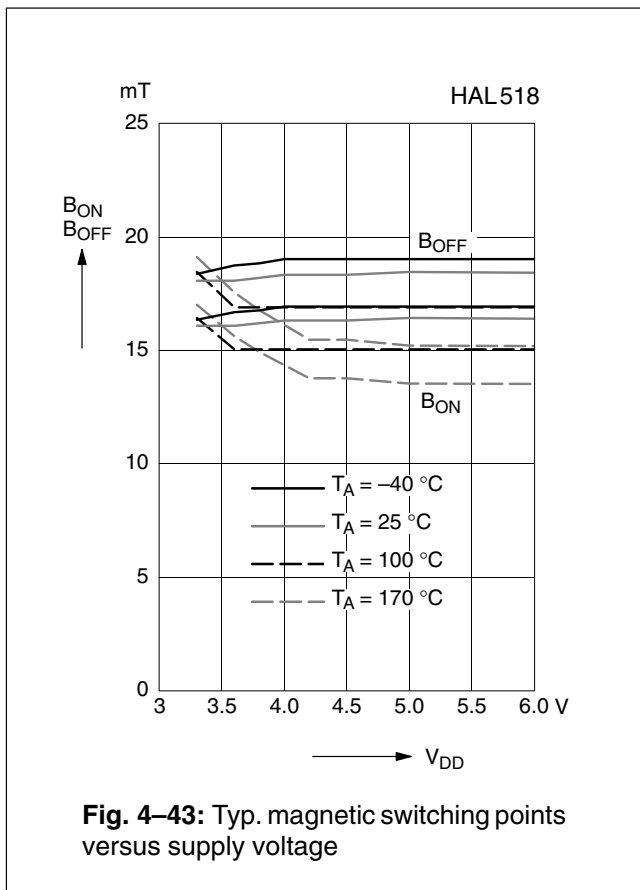
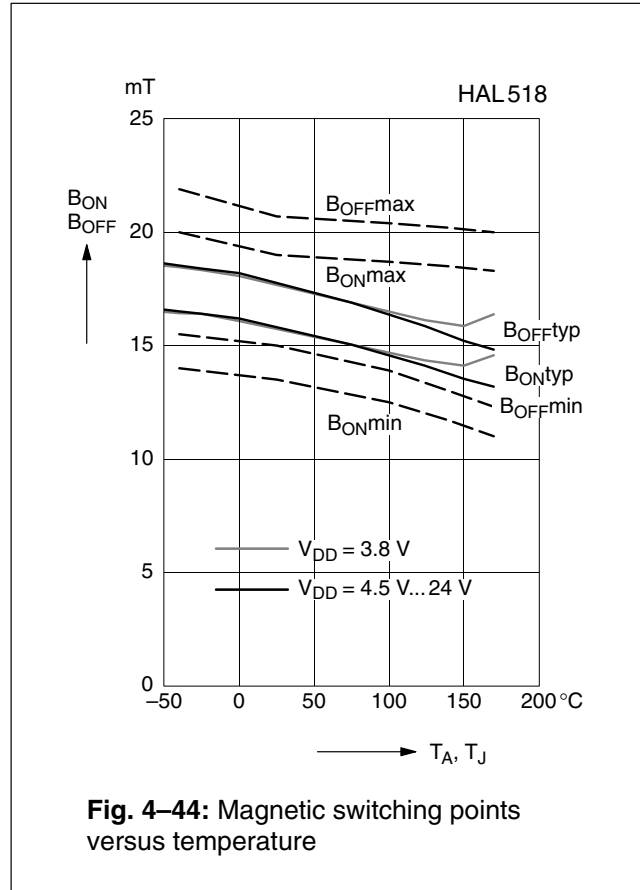
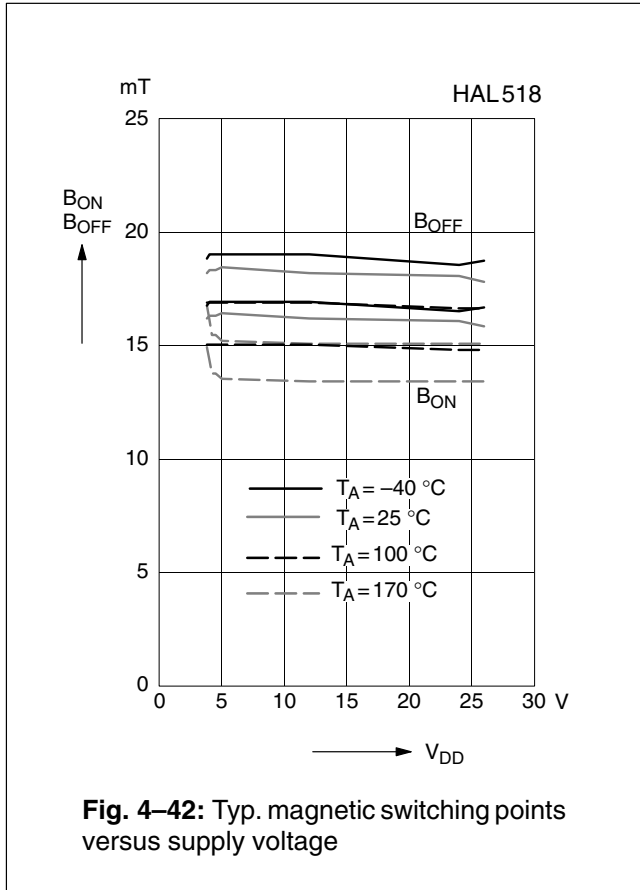

Note: In the diagram “Magnetic switching points versus temperature” the curves for B_{ONmin} , B_{ONmax} , B_{OFFmin} , and B_{OFFmax} refer to junction temperature, whereas typical curves refer to ambient temperature.

4.12. HAL519

The HAL519 is a very sensitive unipolar switching sensor with an inverted output sensitive only to the magnetic north polarity. (see Fig. 4–45).

The output turns high with the magnetic north pole on the branded side of the package and turns low if the magnetic field is removed. The sensor does not respond to the magnetic south pole on the branded side, the output remains low. For correct functioning in the application, the sensor requires only the magnetic north pole on the branded side of the package.

Magnetic Features:

- switching type: unipolar inverted, north sensitive
- high sensitivity
- typical B_{ON} : -3.5 mT at room temperature
- typical B_{OFF} : -5.5 mT at room temperature
- operates with static magnetic fields and dynamic magnetic fields up to 10 kHz
- typical temperature coefficient of magnetic switching points is -1000 ppm/K

Applications

The HAL519 is the optimal sensor for all applications with the north magnetic polarity and weak magnetic amplitude at the sensor position where an inverted output signal is required such as:

- solid state switches,
- contactless solution to replace micro switches,
- position and end point detection, and
- rotating speed measurement.

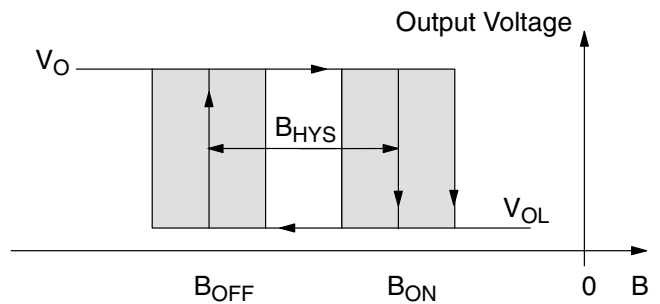

Fig. 4–45: Definition of magnetic switching points for the HAL519

Magnetic Characteristics at $T_J = -40\text{ °C}$ to $+170\text{ °C}$, $V_{DD} = 3.8\text{ V}$ to 24 V , Typical Characteristics for $V_{DD} = 12\text{ V}$

Magnetic flux density values of switching points. Positive flux density values refer to the magnetic south pole at the branded side of the package.

Parameter T_J	On point B_{ON}			Off point B_{OFF}			Hysteresis B_{HYS}			Magnetic Offset			Unit
	Min.	Typ.	Max.	Min.	Typ.	Max.	Min.	Typ.	Max.	Min.	Typ.	Max.	
-40 °C	-5.4	-3.8	-2.1	-7.7	-5.9	-4.3	1.6	2.1	2.8		-4.8		mT
25 °C	-5	-3.6	-2	-7.2	-5.5	-3.8	1.5	1.9	2.7	-6.2	-4.5	-3.8	mT
140 °C	-5.1	-3.1	-1.7	-6.8	-4.8	-3.1	1	1.7	2.6		-4		mT
170 °C	-5.2	-3	-1.5	-6.8	-4.6	-2.8	0.9	1.6	2.6		-3.8		mT

The hysteresis is the difference between the switching points $B_{HYS} = B_{ON} - B_{OFF}$
 The magnetic offset is the mean value of the switching points $B_{OFFSET} = (B_{ON} + B_{OFF}) / 2$

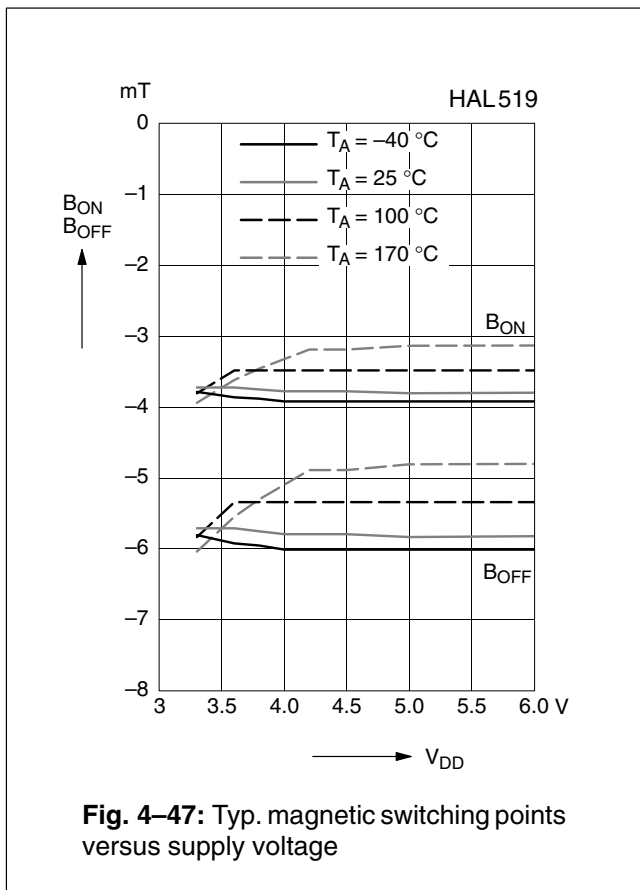
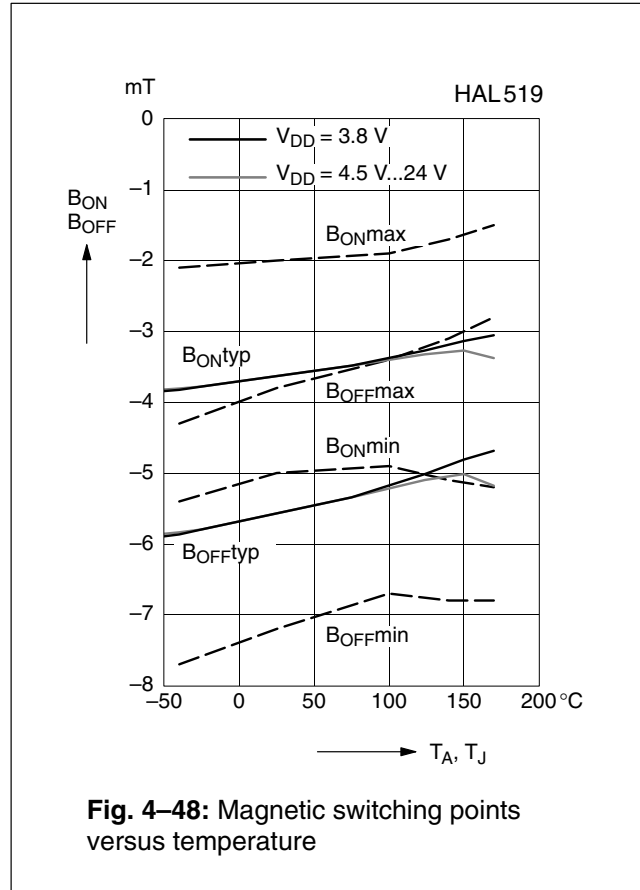
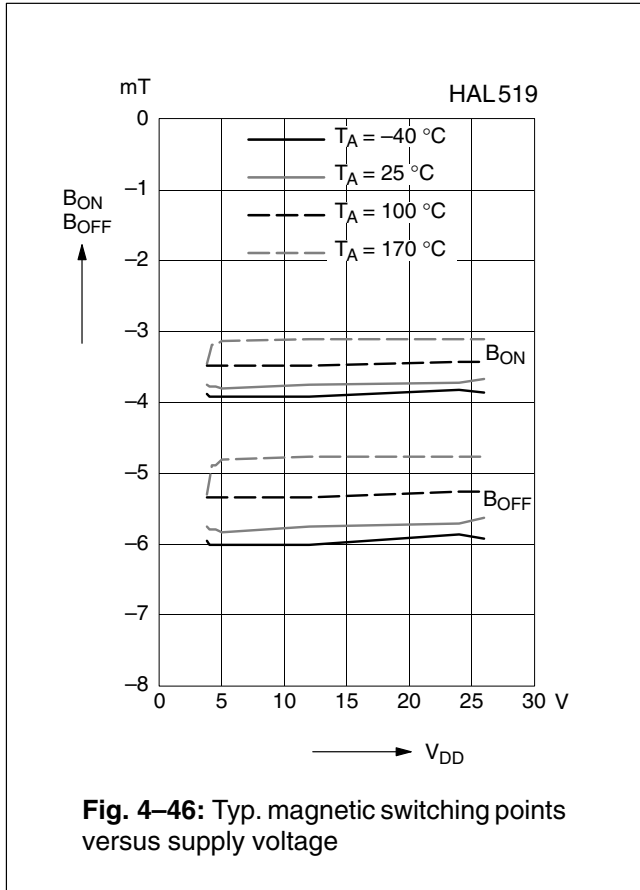

Note: In the diagram “Magnetic switching points versus temperature” the curves for B_{ONmin} , B_{ONmax} , B_{OFFmin} , and B_{OFFmax} refer to junction temperature, whereas typical curves refer to ambient temperature.

4.13. HAL523

The HAL523 is the least sensitive unipolar switching sensor of this family (see Fig. 4–49).

The output turns low with the magnetic south pole on the branded side of the package and turns high if the magnetic field is removed. The sensor does not respond to the magnetic north pole on the branded side.

For correct functioning in the application, the sensor requires only the magnetic south pole on the branded side of the package.

Magnetic Features:

- switching type: unipolar
- low sensitivity
- typical B_{ON} : 34.5 mT at room temperature
- typical B_{OFF} : 24 mT at room temperature
- operates with static magnetic fields and dynamic magnetic fields up to 10 kHz

Applications

The HAL523 is the optimal sensor for applications with one magnetic polarity and strong magnetic fields at the sensor position such as:

- solid state switches,
- contactless solution to replace micro switches,
- position and end point detection, and
- rotating speed measurement.

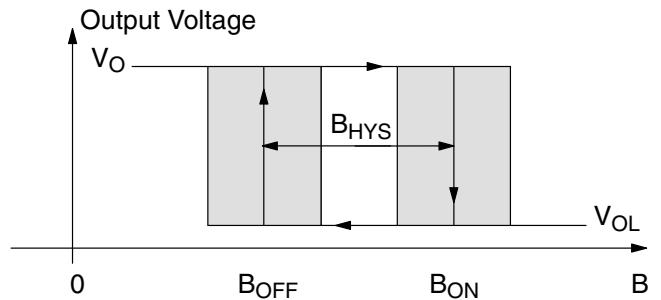

Fig. 4–49: Definition of magnetic switching points for the HAL523

Magnetic Characteristics at $T_J = -40\text{ °C}$ to $+170\text{ °C}$, $V_{DD} = 3.8\text{ V}$ to 24 V , Typical Characteristics for $V_{DD} = 12\text{ V}$

Magnetic flux density values of switching points.

Positive flux density values refer to the magnetic south pole at the branded side of the package.

Parameter T_J	On point B_{ON}			Off point B_{OFF}			Hysteresis B_{HYS}			Magnetic Offset			Unit
	Min.	Typ.	Max.	Min.	Typ.	Max.	Min.	Typ.	Max.	Min.	Typ.	Max.	
-40 °C	28	34.5	42	18	24	30	7	10.5	14		29.3		mT
25 °C	28	34.5	42	18	24	30	7	10.5	14		29.3		mT
140 °C	28	34.5	42	18	24	30	7	10.5	14		29.3		mT
170 °C	28	34.5	42	18	24	30	7	10.5	14		29.3		mT

The hysteresis is the difference between the switching points $B_{HYS} = B_{ON} - B_{OFF}$
 The magnetic offset is the mean value of the switching points $B_{OFFSET} = (B_{ON} + B_{OFF}) / 2$

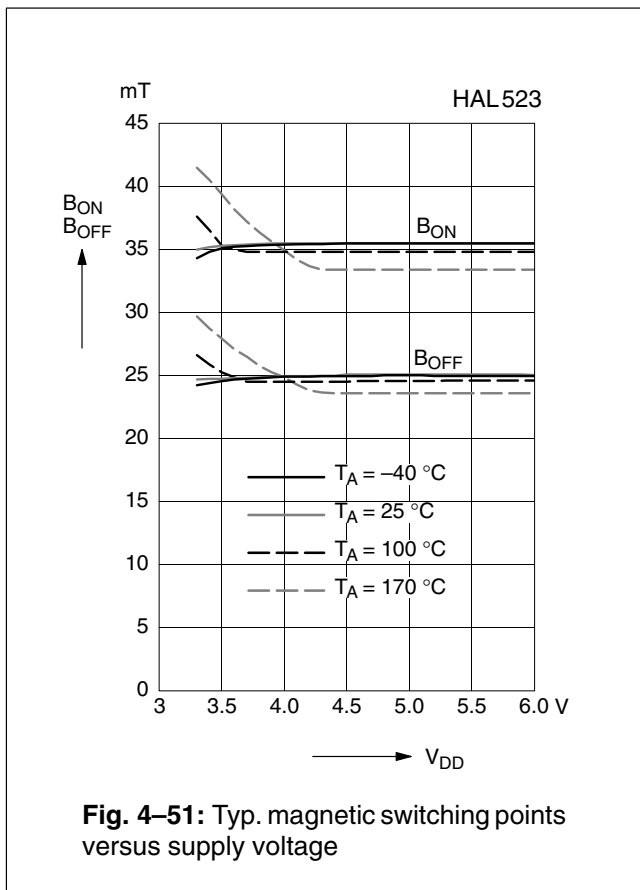
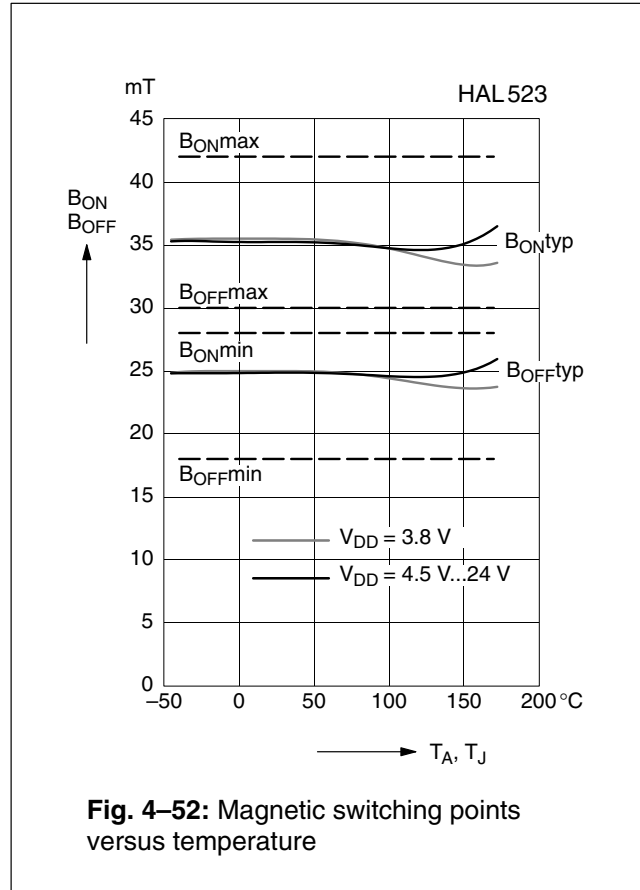
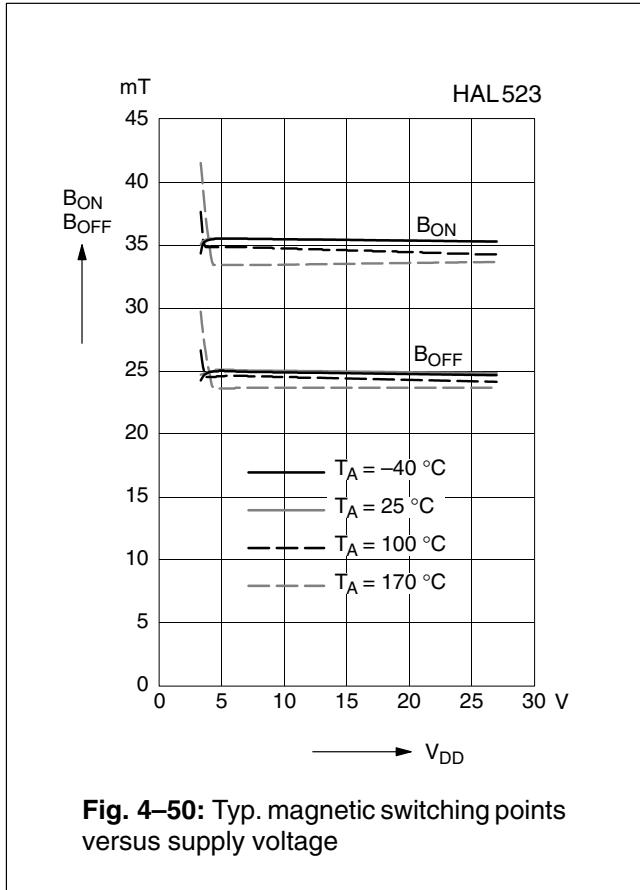

Note: In the diagram “Magnetic switching points versus temperature” the curves for B_{ONmin} , B_{ONmax} , B_{OFFmin} , and B_{OFFmax} refer to junction temperature, whereas typical curves refer to ambient temperature.

5. Application Notes

WARNING:

DO NOT USE THESE SENSORS IN LIFE-SUPPORTING SYSTEMS, AVIATION, AND AEROSPACE APPLICATIONS!

5.1. Ambient Temperature

Due to the internal power dissipation, the temperature on the silicon chip (junction temperature T_J) is higher than the temperature outside the package (ambient temperature T_A).

$$T_J = T_A + \Delta T$$

Under static conditions and continuous operation, the following equation applies:

$$\Delta T = I_{DD} * V_{DD} * R_{th}$$

For all sensors, the junction temperature range T_J is specified. The maximum ambient temperature T_{Amax} can be calculated as:

$$T_{Amax} = T_{Jmax} - \Delta T$$

For typical values, use the typical parameters. For worst case calculation, use the max. parameters for I_{DD} and R_{th} , and the max. value for V_{DD} from the application.

5.2. Extended Operating Conditions

All sensors fulfill the electrical and magnetic characteristics when operated within the Recommended Operating Conditions (see page 12).

Supply Voltage Below 3.8 V

Typically, the sensors operate with supply voltages above 3 V, however, below 3.8 V some characteristics may be outside the specification.

Note: The functionality of the sensor below 3.8 V is not tested on a regular base. For special test conditions, please contact Micronas.

5.3. Start-up Behavior

Due to the active offset compensation, the sensors have an initialization time (enable time $t_{en(O)}$) after applying the supply voltage. The parameter $t_{en(O)}$ is specified in the Electrical Characteristics (see page 13).

During the initialization time, the output state is not defined and the output can toggle. After $t_{en(O)}$, the output will be low if the applied magnetic field B is above B_{ON} . The output will be high if B is below B_{OFF} . In case of sensors with an inverted switching behavior (HAL516 ... HAL519), the output state will be high if $B > B_{OFF}$ and low if $B < B_{ON}$.

Note: For magnetic fields between B_{OFF} and B_{ON} , the output state of the HAL sensor will be either low or high after applying V_{DD} . In order to achieve a defined output state, the applied magnetic field must be above B_{ON} , respectively, below B_{OFF} .

5.4. EMC and ESD

For applications with disturbances on the supply line or radiated disturbances, a series resistor and a capacitor are recommended (see figures 5–1). The series resistor and the capacitor should be placed as closely as possible to the HAL sensor.

Applications with this arrangement passed the EMC tests according to the product standards DIN 40839.

Note: The international standard ISO 7637 is similar to the product standard DIN 40839.

Please contact Micronas for the detailed investigation reports with the EMC and ESD results.

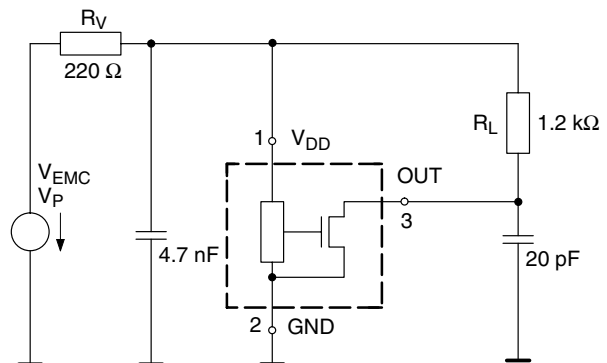

Fig. 5–1: Test circuit for EMC investigations

6. Data Sheet History

1. Final data sheet: "HAL501...506, 508, 509, 516... 518, Hall Effect Sensor Family, Aug. 11, 1999, 6251-485-1DS. First release of the final data sheet. Major changes to the previous edition "HAL501 ... HAL506, HAL 508", Hall Effect Sensor ICs, May 5, 1997, 6251-405-1DS:
 - additional types: HAL509, HAL516 ... HAL518
 - additional package SOT-89B
 - additional temperature range "K"
 - outline dimensions for SOT-89A and TO-92UA changed
 - absolute maximum ratings changed
 - electrical characteristics changed
 - magnetic characteristics for HAL 501, HAL 503, HAL 506, and HAL 509 changed
2. Final data sheet: "HAL501...506, 508, 509, 516... 519, 523, Hall Effect Sensor Family", Feb. 14, 2001, 6251-485-2DS. Second release of the final data sheet. Major changes:
 - additional types: HAL519, HAL523
 - phased-out package SOT-89A removed
 - temperature range "C" removed
 - outline dimensions for SOT-89B: reduced tolerances
3. Final data sheet: "HAL501...506, 508, 509, 516... 519, 523, Hall Effect Sensor Family", Oct. 7, 2002, 6251-485-3DS. Third release of the final data sheet. Major changes:
 - temperature range "E" removed
 - outline dimensions for TO-92UA: package diagram updated
 - absolute maximum ratings changed
 - section 3.4.1. added
 - electrical characteristics changed
 - magnetic characteristics changed
4. Final data sheet: "HAL501...506, 508, 509, 516... 519, 523, Hall Effect Sensor Family", Nov. 27, 2003, 6251-485-4DS. Fourth release of the final data sheet. Major changes:
 - new package diagrams for SOT89-1 and TO92UA-1
 - package diagram for TO92UA-2 added
 - ammopack diagrams for TO92UA-1/-2 added

Micronas GmbH
 Hans-Bunte-Strasse 19
 D-79108 Freiburg (Germany)
 P.O. Box 840
 D-79008 Freiburg (Germany)
 Tel. +49-761-517-0
 Fax +49-761-517-2174
 E-mail: docservice@micronas.com
 Internet: www.micronas.com

Printed in Germany
 Order No. 6251-485-4DS

All information and data contained in this data sheet are without any commitment, are not to be considered as an offer for conclusion of a contract, nor shall they be construed as to create any liability. Any new issue of this data sheet invalidates previous issues. Product availability and delivery are exclusively subject to our respective order confirmation form; the same applies to orders based on development samples delivered. By this publication, Micronas GmbH does not assume responsibility for patent infringements or other rights of third parties which may result from its use.

Further, Micronas GmbH reserves the right to revise this publication and to make changes to its content, at any time, without obligation to notify any person or entity of such revisions or changes.

No part of this publication may be reproduced, photocopied, stored on a retrieval system, or transmitted without the express written consent of Micronas GmbH.