

NDIR TYPE INFRARED GAS ANALYZER (3-COMPONENT ANALYZER)

DATA SHEET

ZKJ7

This product is the replacement of our gas analyzer <model: ZRG>

This gas analyzer (ZKJ7) is capable of measuring the concentrations of NO, SO₂, CO₂, CO, CH₄ and O₂ components in sample gas.

NO, SO₂, CO₂, CO, CH₄ are measured by non-dispersion infrared method (NDIR), while O₂ is measured by external-mount type zirconia method sensor. A maximum of three components including O₂ are simultaneously measurable. The mass flow type twin detector of high sensitivity and reliability adopted in the infrared ray method detection block makes the measurement hardly affected by interfering components.

In addition, a microprocessor is built in and a large-size liquid crystal display is equipped for easier operation, higher accuracy and more functions.

Optimum as an analyzer unit of gas measurement system for combustion exhaust gas from refuse incinerator and boiler, or gas from different industrial furnaces.

Combination of this product and model sampling system (ZSU) is satisfied authentication test by measurement act.



FEATURES

1. Measure three components including O₂ simultaneously and continuously
Simultaneously and continuously measures up to three components out of NO, SO₂, CO₂, CO, CH₄, plus O₂, or up to totally three components.
2. Hardly affected by interference by other gases
The mass flow type twin detector of high sensitivity and reliability adopted makes the measurement hardly affected by interfering components of other gas, ensuring a stable operation.
3. Equipped with abundant functions
O₂ conversion, average value computation, automatic calibration, one touch calibration, upper/lower limit alarm, remote measurement range changeover, range identification signal output, etc. incorporated can configure applications to match particular uses.
4. Easy-to-see large LCD unit
The large LCD unit adopted allows observing easily the indication of all measured components and computation values.
The interactive operation facilitates setting.
5. Maximum range ratio is 1:25
Measuring ranges are changeable.
6. Drift +/-1% FS/week (more than 0 to 200ppm range)

SPECIFICATIONS

Standard Specifications

Principle of measurement:

NO, SO₂, CO₂, CO, CH₄;

Non-dispersion infrared-ray absorption method

Single light source and double beams (double-beam system)

O₂ ; Exclusive zirconia O₂ sensor (externally installed). Model: ZFK7

Measurable gas components and measuring range:

	Minimum range	Maximum range
NO	0 – 100ppm	0 – 5000ppm
SO ₂	0 – 100ppm	0 – 10vol%
CO ₂	0 – 100ppm	0 – 100vol%
CO	0 – 100ppm	0 – 100vol%
CH ₄	0 – 200ppm	0 – 100vol%
O ₂ (External Zirconia)	0 – 10vol%	0 – 25vol%

- Max. 3 components measurement including O₂.
- Measuring range ratio ≤ 1:5 (O₂ sensor) ≤ 1:25 (except for O₂ sensor)
- Measuring ranges are changeable between the specified minimum and maximum range
Settable one range or two ranges

*For measurable components and possible combinations of measuring ranges, refer to Tables 1-(1) to (3).

Measured value indication:

- Digital indication in 4 digits (LCD with back light)
- Instantaneous value of each component
- Instantaneous value after O₂ conversion (only in NO, SO₂, CO sensor with O₂ sensor)
- Average value after O₂ conversion (only in NO, SO₂, CO sensor with O₂ sensor)

Analog output signals:

4 to 20mA DC or 0 to 1V DC, non-isolated output ; 7 points max.
 Analog output corresponds to measured value indication in 1:1.
 max.load 550Ω. for 4 to 20 mA DC
 min.load 100kΩ. for 0 to 1V DC
 * Refer to Table 2, for the channel No. of displayed values and analog output signals.

Analog input signal:

For signal input from externally installed O₂ sensor.
 Signal requirement;
 (1) Signal from Fuji's Zirconia O₂ sensor (TYPE: ZFK7)
 (2) 0 to 1V DC from an O₂ sensor
 Input section is not isolated.
 (Depend on O₂ input signal, measured concentration indication and O₂ conversion.)

Relay contact output:

1a contact (250V AC/2A, resistive load)
 Instrument error, calibration error, range identification, auto calibration status, pump ON/OFF.
 solenoid valve drive signal for auto calibration, auto calibration end.
 1c contact (250V AC/2A, resistive load selectable 6 outputs)
 High/Low limit alarm contact output.
 * All relay contacts are isolated mutually and from the internal circuit.

Contact input:

No-voltage contact (ON/0V, OFF/5V DC, 5mA flowing at ON)
 * For ZRG (ON/5V, OFF/0V)
 Remote range switch, auto calibration remote start, remote holding, average value reset.
 Isolated from the internal circuit with photocoupler. Contact inputs are not isolated from one another.

Power supply:

Voltage rating ; 100V to 240V AC
 Allowable range; 85V to 264V AC
 Frequency ; 50Hz/60Hz
 Power consumption; 250VA max.

Operating conditions:

Ambient temperature; -5°C to 45°C
 Ambient humidity ; 90% RH max., non-condensing

Storage conditions:

Ambient temperature; -20°C to 60°C
 Ambient humidity ; 95% RH max., non-condensing

Dimensions (H x W x D):

Analyzer main unit;
 835 x 218 x 202mm

Mass:

Approx. 16 kg

Finish color:

Front panel; Off-white (Munsell 10Y7.5/0.5 or equivalent)

Enclosure:

Steel casing, for indoor use

Material of gas-contacting parts:

Gas inlet/outlet; Teflon
 Sample cell; SUS304, chloroprene rubber
 Infrared-ray transmitting window; CaF₂
 O₂ sensor sample cell : SUS316
 Internal piping; Toaron, Teflon

Gas inlet/outlet:

Rc¹/₄ or ø6 hose end

Purge gas flow rate: 1L/min (when required)

Standard Functions

Output signal holding:

Output signals are held during manual and auto calibrations by activation of holding (turning "ON" its setting).

The values to be held are the ones just before start calibration mode or setting value.

It is selectable.

Indication of instantaneous values will not be held.

Remote output holding:

Output signal is held at the latest value or setting value by short-circuiting the remote output holding input terminals.

Holding is maintained while the terminals are short-circuited. Indication of instantaneous values will not be held.

Switch ranges :

The switch ranges is available in manual, auto, and remote modes. Only preset switch method is effective.

Manual: Allows range to switch by key operation.

Auto: Allows range to switch from low to high range when 90%FS or more is available in the low range.

Allows range to switch from high to low range when 80%FS or less is available in the low range.

Remote: No-voltage contact input (for measurable components)

Allows range to switch via an external signal when remote range switch input is received.

When the contact input terminals for each component are short-circuited, the first range is selected, and it is switched to the second range when the terminals are open.

Range identification signal:

The present measuring range is identified by a contact signal.

The contact output terminals for each component are short-circuited when the first range is selected, and when the second range is selected, the terminals are open.

Auto calibration:

Auto calibration is carried out periodically at the preset cycle.

When a standard gas cylinder for calibration and a solenoid valve for opening/closing the gas flow line are prepared externally by the customer, calibration will be carried out with the solenoid valve drive contacts for zero calibration and each span calibration turned on/off sequentially at the set auto calibration timing.

Auto calibration cycle setting:

Auto calibration cycle is set.

Setting is variable within 1 to 99 hours (in increments of 1 hour) or 1 to 40 days (in increments of 1 day).

Gas flow time setting:

The time for flowing each calibration gas in auto calibration is set.

Settable within 60 to 900 seconds (in increments of 1 second)

Auto calibration remote start:

Auto calibration is carried out only once according to an external input signal. Calibration sequence is settable in the same way as the general auto calibration.

Auto calibration is started by opening the auto calibration remote start input terminals after short-circuiting for 1.5 seconds or longer.

Auto zero calibration:

Auto zero calibration is carried out periodically at the preset cycle.

This cycle is independent on "Auto calibration" cycle.

When zero calibration gas and solenoid valve for opening/closing the calibration gas flow line are prepared externally by the customer, zero calibration will be carried out with the solenoid valve drive contact for zero calibration turned on/off at the set auto zero calibration timing.

Auto zero calibration cycle setting:

Auto zero calibration cycle is set.

Setting is variable within 1 to 99 hours (in increments of 1 hour) or

Setting is variable within 1 to 40 days (in increments of 1 day)

Gas flow time setting:

The timing for flowing zero gas in auto zero calibration is set.

Settable 60 to 900 seconds (in increments of 1 second)

High/Low limit alarm:

Alarm contact output turns on when measurement value reach to the preset high or low limit alarm value.

Contacts close when the channel value of each channel becomes larger than the high alarm limit value or smaller than the low alarm limit value.

Instrument error contact output:

Contacts close at occurrence of analyzer error No. 1, 3 or 10.

Calibration error contact output:

Contacts close at occurrence of manual or auto calibration error (any of errors No. 4 to 9).

Auto calibration status contact outputs:

Contacts close during auto calibration.

Pump ON/OFF contact output:

During measurement, this contact close. While calibration gas is flowing, this contact open. This contact is connected in power supply of pump, and stop the sample gas while calibration gas flowing.

Average value reset:

Average value after O₂ conversion is started under preset condition by opening the average value reset input terminals after short-circuiting for 1.5 seconds or longer.

Reset is carried out by short-circuiting. Restart is carried out by opening.

Auto calibration interlocking function:

When these two products are lined up and installed, output the auto calibration synchronized signal to second product.

Contact output during auto calibration:

While auto calibration is carried out, this contact is closed.

Auto calibration end contact output:

Contact is closed for 1.5 seconds after finishing to flow the gas of auto calibration.

Optional Functions

O₂ conversion: Conversion of measured NO, SO₂ and CO gas concentrations into values at standard O₂ concentration

$$\text{Conversion formula: } C = \frac{21 - O_n}{21 - O_s} \times C_s$$

C : Sample gas concentration after O₂ conversion

C_s: Measured concentration of sample gas

O_s: Measured O₂ concentration (Limit settable, 1 to 20%O₂)

O_n: Standard O₂ concentration (value changeable by setting; 0 to 19%O₂)

Average value after O₂ conversion :

The result of O₂ conversion or instantaneous O₂ value can be outputted as an average value in the preset period of time.

Used for averaging is the moving average method in which sampling is carried out at intervals of 30 seconds.

(Output is updated every 30 seconds. It is the average value in the determined period of time just before the latest updating.)

Averaging time is settable within 1 to 59 minutes (in increments of 1 minute) or 1 to 4 hours (in increments of 1 hour).

Communication function:

RS-232C (9pins D-sub)

Half-duplex bit serial

Start-stop synchronization

Modbus™ protocol

Contents: Read/Wright parameters

Read measurement concentration and instrument status

Remark: When connecting via RS-485 interface, a RS-232C ↔ RS-485 converter should be used.

Performance

- Repeatability** : ±0.5% of full scale
- Linearity** : ±1% of full scale
- Zero drift** : ±1% of full scale/week
(±2% of full scale/week; range between 0 to 100ppm and 0 to 200ppm)
- Span drift** : ±2% of full scale/week
- Response time** :
(for 90% FS response)
15 sec electrical response
Within 60 seconds including replacement time of sampling gas (when gas flow rate is 0.5L/min)
Gas replacement time depends on the number of measuring components and measuring range

Standard Requirements for Sample Gas

- Flow rate** : 0.5L / min ±0.2L / min
- Temperature** : 0 to 50°C
- Pressure** : 10 kPa or less (Gas outlet side should be open to the atmospheric air.)
- Dust** : 100µg/Nm³ or less in particle size of 1µm or less
- Mist** : Unallowable
- Moisture** : Below a level where saturation occurs at 2°C (condensation unallowable).

Corrosive component:

1 ppm or less

Standard gas for calibration:

Zero gas ; Dry N₂

Span gas ; Each sample gas having concentration 90 to 100% of its measuring component range (recommended).

Gas beyond concentration 100%FS is unusable.

In case a zirconia O₂ analyzer is installed externally and calibration is carried out on the same calibration gas line:

Zero gas ; Dry air or atmospheric air (provided without CO₂ sensor)

Span gas ; Except O₂ measurement, each sample gas having concentration 90 to 100% of its measuring range. For O₂ sensor, O₂ gas of 1 to 2vol%.

Installation Requirements

- Indoor use. (Select a place where the equipment does not receive direct sunshine, draft/rain or radiation from hot substances. If such a place cannot be found, a roof or cover should be prepared for protection.)
- Avoid a place where receives heavy vibration
- Select a place where atmospheric air is clean

EC Directive Compliance

The product conforms to requirement of the Low Voltage Directive and EMC directive.

It conforms to following standards for product safety and electromagnetic compatibility ;

EN61010-1 : 2001, EN62311 : 2008

Safety requirements for electrical equipment for measurement, control and laboratory use.

EN61326-1~2006

EN61326-2-3 : 2006, EN61000-3-2 : 2006, A1: 2009, A2: 2009,

EN61000-3-3 : 2008

Electrical equipment for measurement, control and laboratory use – EMC requirements.

*The product mounted in a steel enclosure conforms to the requirements of EMC directive.

ZRG ↔ ZKJ7 differences

	ZRG	ZKJ7
Contact input	DC5V	No-voltage contact
Zirconia O ₂ analyzer	ZFK3, 4	ZFK7
Average value	Calculation is always carried out even during holding.	Calculation is suspended during holding
Calibration error contact	Auto calibration status error	Calibration status error (Auto/manual)

Principle diagram of NDIR type measurement (For NO, SO₂, CO₂, CO)

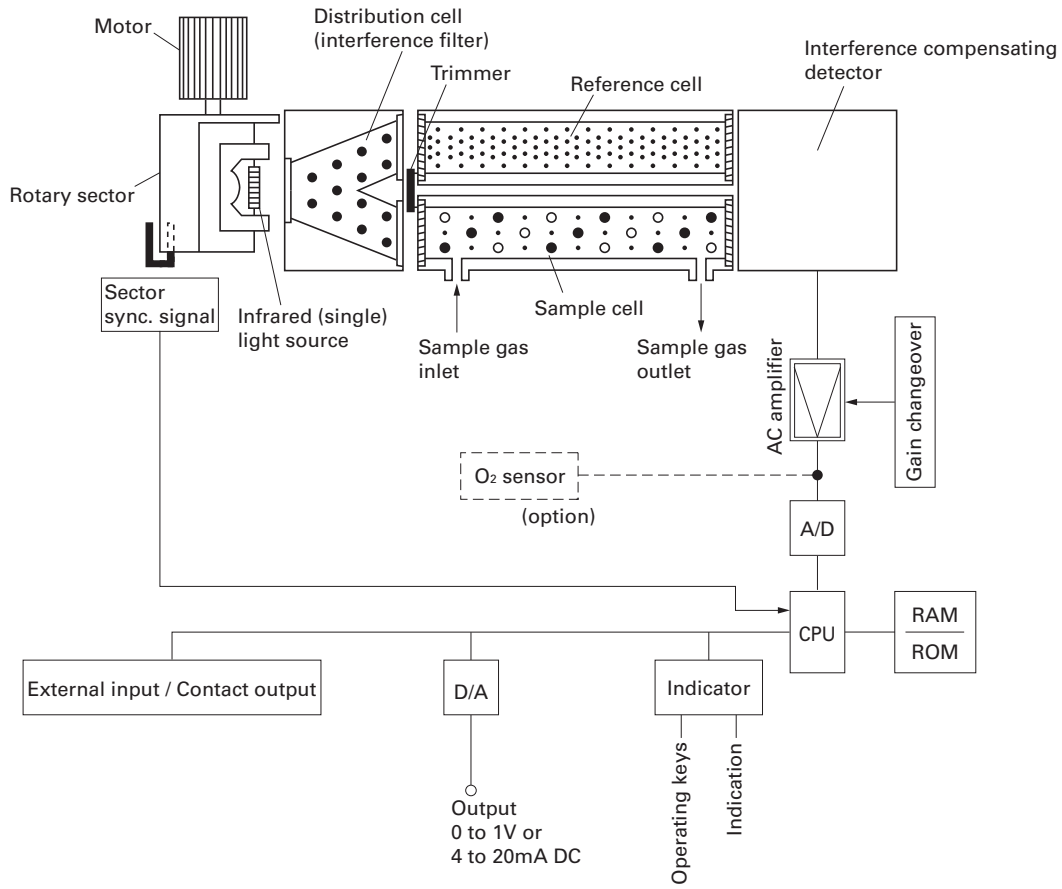

Example configuration of gas sampling system

The following illustrates a typical system configuration for five component gas measurement for monitoring combustion exhaust gas from boiler, refuse incinerator, etc.

Contact FUJI ELECTRIC for system configuration matching the particular use or further information.

In the case infrared gas analyzer (Model: ZRG) is replaced, Zirconia O₂ sensor should also be replaced.

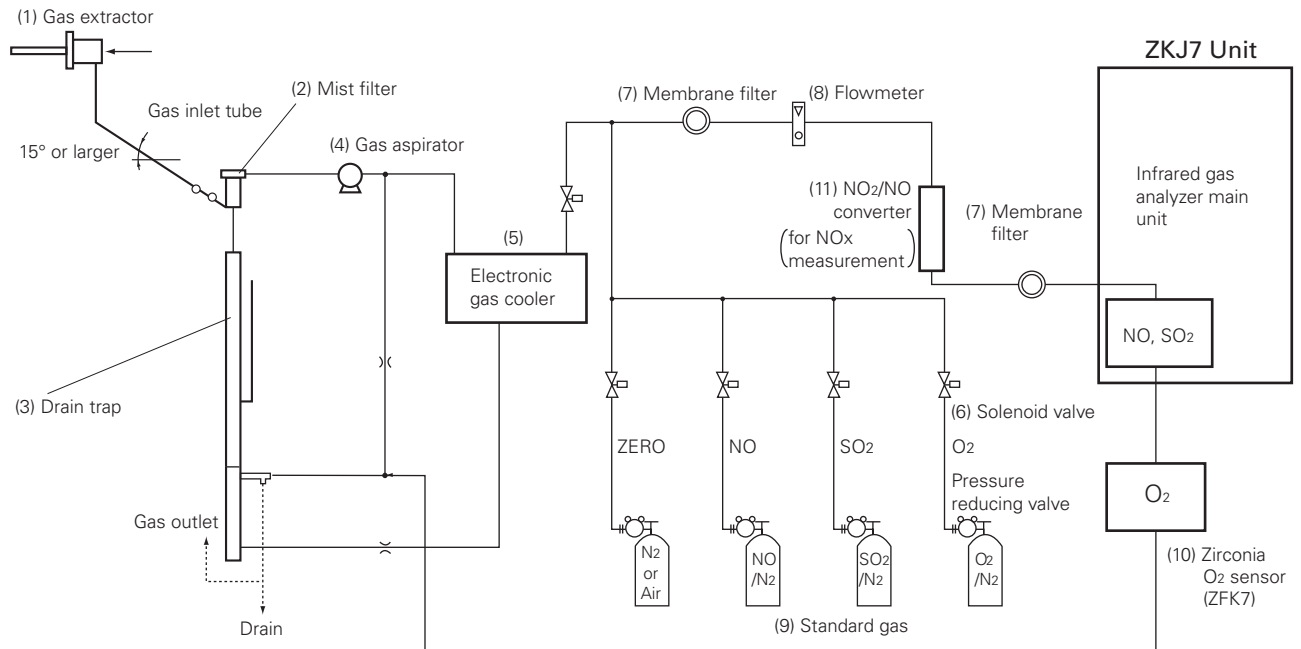

Functions of Individual Components

- (1) **Gas extractor:** Gas extractor with a heating type stainless steel filter of standard mesh 40 μ m
- (2) **Mist filter:** For separation of drain and removal of dust and mist
- (3) **Safety drain trap:** Prevention of drain from being sucked and composite operation of constant-pressure bubbler
- (4) **Gas aspirator:** For aspiration of sample gas (sample gas flow rate approx. 2L/min)
- (5) **Electronic gas cooler:** Dries the moisture in sample gas to a dew point of approx. 3°C.
- (6) **Solenoid valve:** Used for introducing calibration gas.
- (7) **Membrane filter:** PTFE filter used to eliminate fine dust particles and permit monitoring of dust adhering condition on the front panel of the gas analyzer.

- (8) **Flowmeter:** Adjusts and monitors the flow rate of sample gas.
- (9) **Standard gas:** Reference gas used for calibrating zero and span of the analyzer.
- (10) **Zirconia O₂ sensor:** External zirconia oxygen sensor used for measuring the oxygen concentration (0 to 25%) in sample gas. In the case ZFK3-4 is used, ZFK7 should also be replaced.
- (11) **Converter:** Added to NO_x analyzer. A special catalyst material for efficient conversion of NO₂ gas to NO is used.

*(Note)

For each gas sampling device, refer to the separate Data Sheet for each gas sampling device.

CODE SYMBOLS

Digit	Description	note	1	2	3	4	5	6	7	8	9	10	11	12	13	14	15	16	17	18	19	20	21	22	23	← Digit No. of code
4	<Custom specifications> Replecement of ZRG type		Z	K	J	7					Y															
5	<Measurable component (NO, SO ₂ , CO ₂ , CO, CH ₄)>																									
	1st component	2nd component																								
	NO																									
	SO ₂																									
	CO ₂																									
	CO																									
	CH ₄																									
	NO	SO ₂																								
	CO ₂	CO																								
	Others																									
6	<Measurable component (O ₂)> None External zirconia type O ₂ sensor (ZFK7 type) External O ₂ analyzer without external indication (input the signal for O ₂ conversion externally)	note 1 note 2, 9																								
7	<Gas inlet/outlet> Rc1/4 (with purging inlet) Teflon φ6 (none purging inlet)																									
8	<Revision code>																									
9	-																									
10	<Indication> In Japanese In English																									
11	<Measuring range> 1st component.1st range 0-100ppm 0-200ppm 0-250ppm 0-500ppm 0-1000ppm	note 3																								
	0-2000ppm 0-5000ppm 0-1% 0-2% 0-5%																									
	0-10% 0-20% 0-50% 0-100% Others																									
12	<Measuring range> 1st component.2nd range None 0-200ppm 0-250ppm 0-500ppm	note 3																								
	0-1000ppm 0-2000ppm 0-5000ppm 0-1% 0-2% 0-5%																									
	0-10% 0-20% 0-50% 0-100% Others																									

Digit	Description	note	1	2	3	4	5	6	7	8	9	10	11	12	13	14	15	16	17	18	19	20	21	22	23	← Digit No. of code
13	<Measuring range> 2nd component.1st range None 0-100ppm 0-200ppm 0-250ppm 0-500ppm 0-1000ppm	note 3	Z	K	J	7				4	-	Y	J			Y	Y	Y	Y							
	0-2000ppm 0-5000ppm 0-1% 0-2% 0-5%														Y											
	0-10% 0-20% 0-50% 0-100% Others														B											
14	<Measuring range> 2nd component.2nd range None 0-200ppm 0-250ppm 0-500ppm 0-1000ppm	note 3																								
	0-2000ppm 0-5000ppm 0-1% 0-2% 0-5%																									
	0-10% 0-20% 0-50% 0-100% Others																									
15	-																Y	Y								
16	-																									
17	-																			Y	Y					
18	-																									
19	<O ₂ sensor range>																									
20	Minimum range	Maximum range																								
	None	None																				Y	Y			
	0-10%	0-25%																				M	V			
	0-25%	None																				V	Y			
	Others																					Z	Z			
21	<Output> 4 to 20mA DC 0 to 1V DC 4 to 20mA DC + communication function 0 to 1V DC + communication function																									
																							A	B	C	D
22	<O ₂ conversion> None With O ₂ conversion output	note 6 note 7																								
																										Y
																										A
23	<Ajustment> For combustion exhaust gas Others	note 8																								
																										B
																										Z

- Note 1** a) when "B" is specified at the 6th digit, O₂ sensor signal should be set as 0-1VDC linear corresponding to full scale.
b) External zirconia O₂ sensor and external O₂ analyzer are not included in the scope of supply.
- Note 2** When two products are lined up and installed, please refer to the corresponding table for measured value to specify the digit for second product. (Please also refer to note 9)
- Note 3** Please refer to the appendix, for possible combination of measuring components and range in the data sheet.
- Note 4** When "Y", "D" is specified at the 6th digit, Only "YY" should be selected.
- Note 5** When two products are lined up and installed, Only "VY" should be selected for both products. (Please also refer to note 9)
- Note 6** Only measuring value of NO, SO₂, CO are calculated as O₂ calculation, O₂ converted average value are outputted at the same time.
- Note 7** When "Y" is specified at the 6th digit, Only "Y" should be selected.
- Note 8** When "Z" is specified at the 23rd digit, gas composition table of actual measured gas has to be sent to Fuji with your purchase order.

Note 9 Precaution to observe when performing installation of two analyzers with external O₂ analyzer

- When two ZKJ7 are lined up side by side and installed with external O₂ analyzer, Be sure to observe connection of external O₂ analyzer shown following diagram on the right side. (with converted value/converted average value)
In this case O₂ indication can not be conducted with second ZKJ7 (due to limitation of measurement)
Please refer to "Connecting method/analog output component" for connection to the terminal.

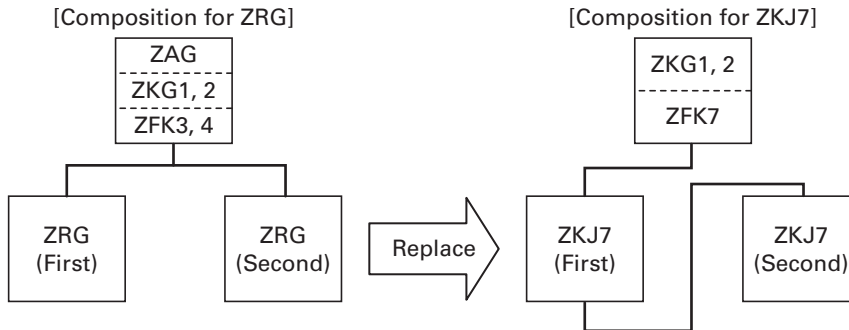

- *First analyzer: This analyzer is connected to O₂ signal directly and indicate O₂ indication.
- Second analyzer: This analyzer is connected to O₂ instantaneous value from first analyzer and could not indicate O₂ indication.

- O₂ range is fixed 0-25%.
- With these connection component for second analyzer should be NO sensor, SO₂ sensor or NO/SO₂ sensor.
Please refer to the "correspondence table for measured value" "Code symbols" for details.
- When ZRG is replaced, two analyzers should be replaced at the same time.

Table 1. Measurable component and range – availability check table –

(*) Range code shows settable combination of the maximum range rate.

(1) Single component analyzer (NO, SO₂, CO₂, CO, CH₄)

☆ : NO Measuring range □ : SO₂ Measuring range ◎ : CO₂ Measuring range
 ○ : CO Measuring range △ : CH₄ Measuring range

2st range \ 1st range		C	D	E	F	G	H	J	K	L	M	N	P	R
		0 ~ 200ppm	0 ~ 250ppm	0 ~ 500ppm	0 ~ 1000ppm	0 ~ 2000ppm	0 ~ 5000ppm	0 ~ 1%	0 ~ 2%	0 ~ 5%	0 ~ 10%	0 ~ 20%	0 ~ 50%	0 ~ 100%
B	0 ~ 100ppm	☆□○○	☆□○○	☆□○○	☆□○○	☆□○○								
C	0 ~ 200ppm		☆□○○△	☆□○○△	☆□○○△	☆□○○△	☆□○○△							
D	0 ~ 250ppm			☆□○○△	☆□○○△	☆□○○△	☆□○○△							
E	0 ~ 500ppm				☆□○○△	☆□○○△	☆□○○△	□○○△						
F	0 ~ 1000ppm					☆□○○△	☆□○○△	□○○△	□○○△					
G	0 ~ 2000ppm						☆□○○△	□○○△	□○○△	□○○△				
H	0 ~ 5000ppm							□○○△	□○○△	□○○△	□○○△			
J	0 ~ 1%								□○○△	□○○△	□○○△	◎○○		
K	0 ~ 2%									□○○△	□○○△	◎○○	◎○○	
L	0 ~ 5%										□○○△	◎○○	◎○○	◎○○
M	0 ~ 10%											◎○○	◎○○	◎○○
N	0 ~ 20%												◎○○	◎○○
P	0 ~ 50%													◎○○
R	0 ~ 100%													◎○○

(2) Double-component analyzer (NO/SO₂)

○ : Double-component analyzer Measuring range (1st range)

NO \ SO ₂		B	C	D	E	F	G	H
		0 ~ 100ppm	0 ~ 200ppm	0 ~ 250ppm	0 ~ 500ppm	0 ~ 1000ppm	0 ~ 2000ppm	0 ~ 5000ppm
B	0 ~ 100ppm	○	○	○	○	○	○	○
C	0 ~ 200ppm	○	○	○	○	○	○	○
D	0 ~ 250ppm	○	○	○	○	○	○	○
E	0 ~ 500ppm	○	○	○	○	○	○	○
F	0 ~ 1000ppm	○	○	○	○	○	○	○
G	0 ~ 2000ppm	○	○	○	○	○	○	○

* 2nd range: Max. NO (0-200ppm), SO₂ (0-5000ppm), Selectable range up to 25 times of 1st. range

(3) Double-component analyzer (CO₂/CO)

①~⑤ : Double-component analyzer Measuring range (1st range)

CO ₂ \ CO		B	C	D	E	F	G	H	J	K	L	M	N	P	R
		0 ~ 100ppm	0 ~ 200ppm	0 ~ 250ppm	0 ~ 500ppm	0 ~ 1000ppm	0 ~ 2000ppm	0 ~ 5000ppm	0 ~ 1%	0 ~ 2%	0 ~ 5%	0 ~ 10%	0 ~ 20%	0 ~ 50%	0 ~ 100%
B	0 ~ 100ppm	①	①	①	①	①	①	①							
C	0 ~ 200ppm	①	①	①	①	①	①	①							
D	0 ~ 250ppm	①	①	①	①	①	①	①							
E	0 ~ 500ppm	①	①	①	①	①	①	①							
F	0 ~ 1000ppm	①	①	①	①	①	①	①							
G	0 ~ 2000ppm	①	①	①	①	①	①	①							
H	0 ~ 5000ppm	①	①	①	①	①	①	①	③	③	③				
J	0 ~ 1%								③	④	④				
K	0 ~ 2%								③	④	④				
L	0 ~ 5%								③	④	④				
M	0 ~ 10%	②	②	②	②	②	②	②				⑤	⑤	⑤	⑤
N	0 ~ 20%	②	②	②	②	②	②	②				⑤	⑤	⑤	⑤
P	0 ~ 50%											⑤	⑤	⑤	⑤
R	0 ~ 100%											⑤	⑤	⑤	⑤

* Max. measuring range as 2nd range is following. Selectable range up to 25times of 1st range.

- ① : CO (0-500ppm), CO₂ (0-5000ppm) ② : CO (0-5000ppm), CO₂ (0-20%)
- ③ : CO (0-50%), CO₂ (0-20%) ④ : Selectable range up to 25 times. ⑤ : CO (0-100%), CO₂ (0-100%)

OUTLINE DIAGRAM (Unit: mm)

<Analyzer main unit>

<Upper>

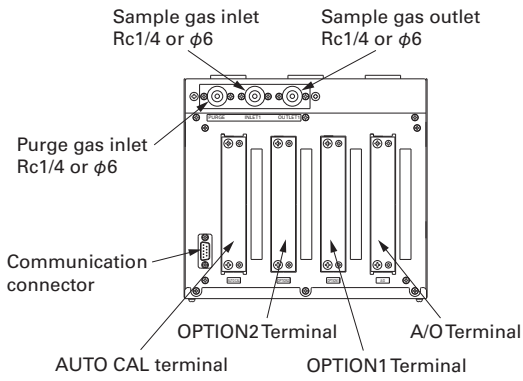

<Mounting size>

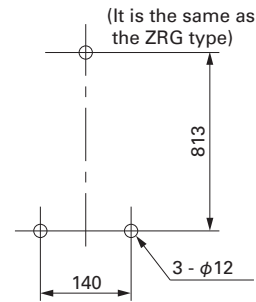

M10 screw is needed formounting to main unit

<Front>

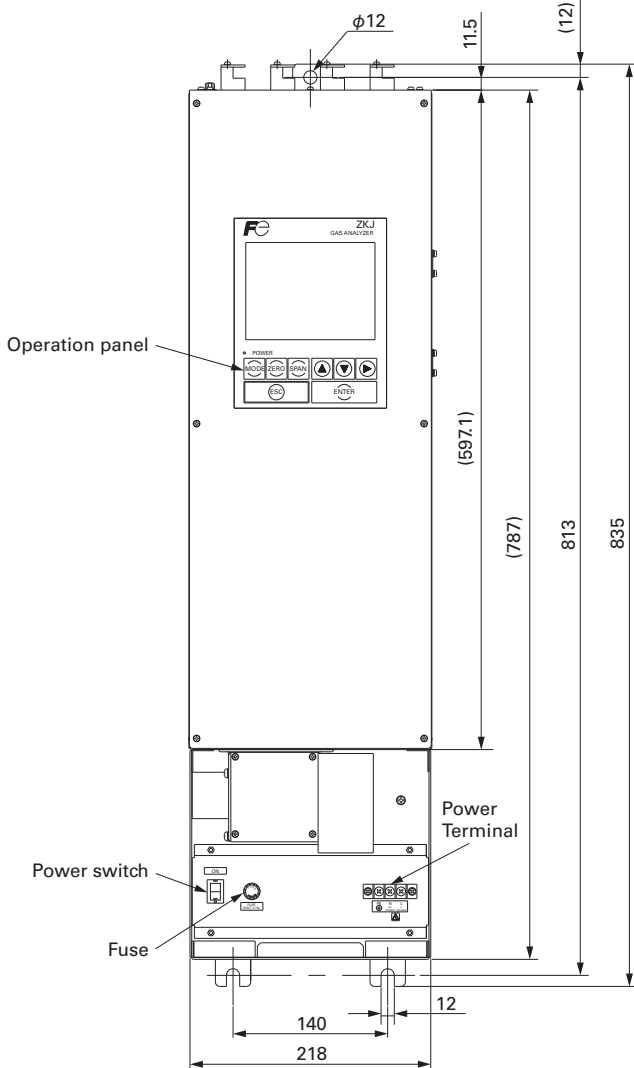

<Side>

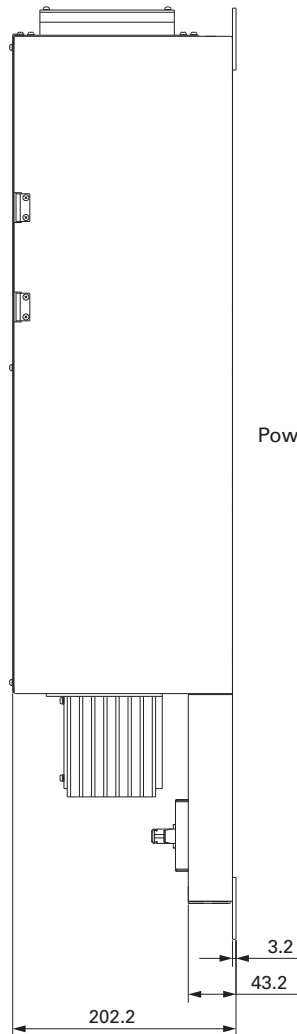

Power supply (M4 screw)

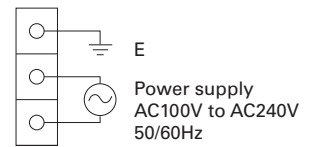

EXTERNAL CONNECTION DIAGRAM

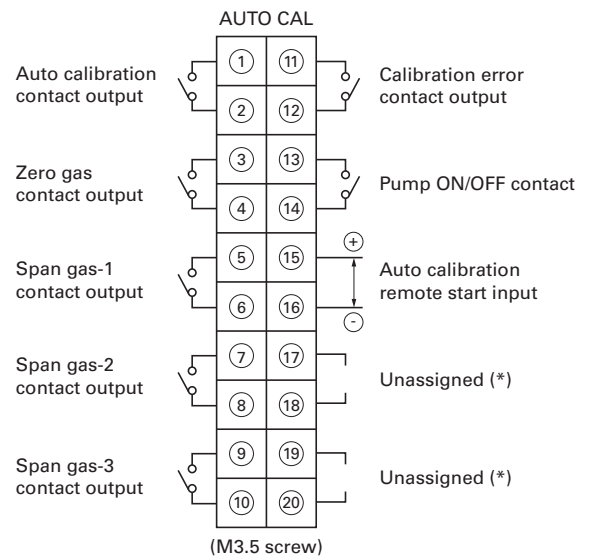
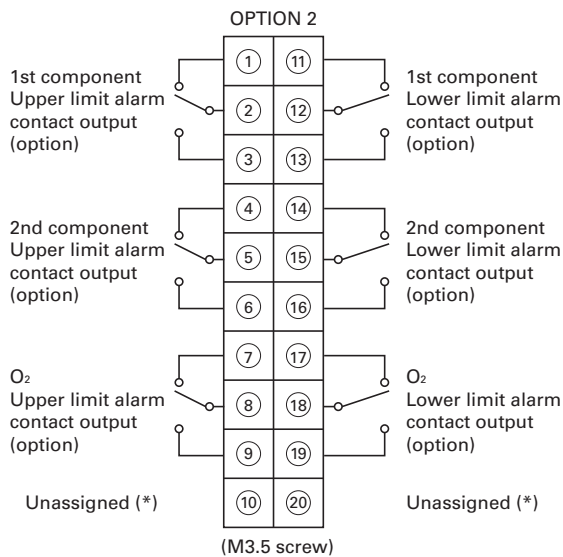
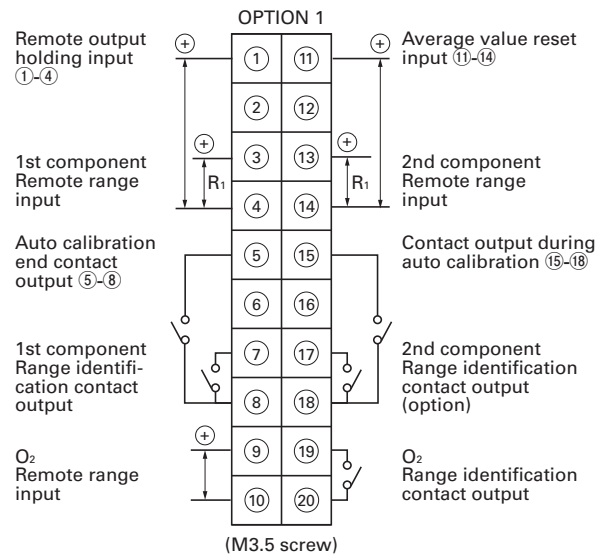
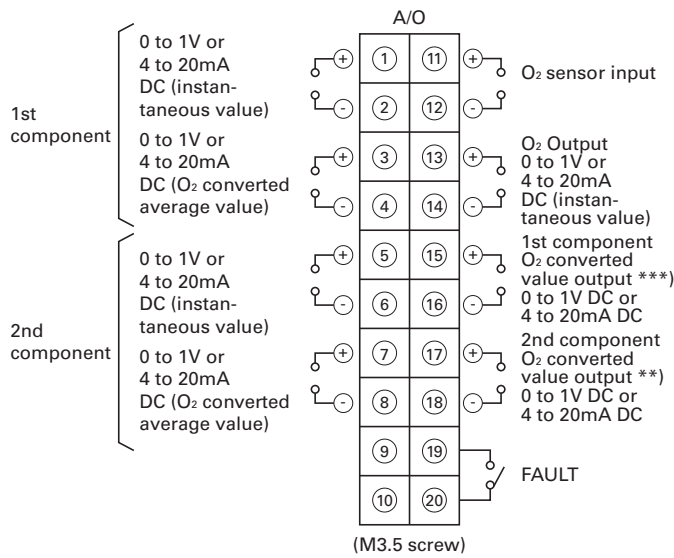

Power supply (M4 screw)

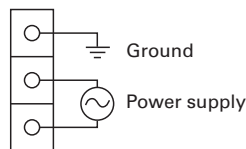

Connector <CN2>
For serial communication

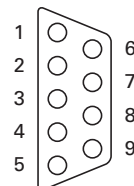

- *) Do not use the terminal for relay.
- **) When two analyzers are lined up and installed with O₂ converted value and converted average value, by First analyzer O₂ instantaneous value (0-1V DC: 0-25% range equivalent) is outputted.
- ***) When two analyzers are lined up and installed and first analyzer is used as CO₂/CO sensor, CO converted value is outputted to 1st component O₂ converted value output.

Connecting method/analog output component

Measurement of NO/SO₂/CO/O₂ sensor [Example connection]
 (with converted value and converted average value)

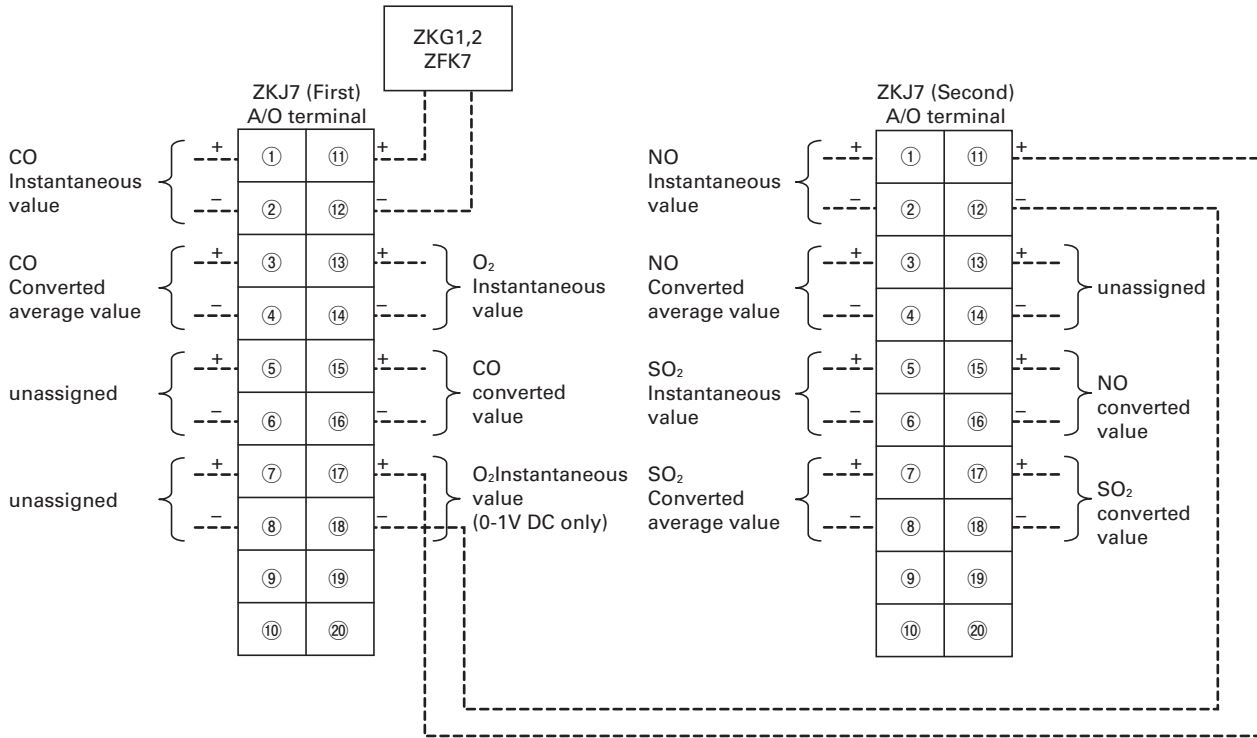

Measurement of NO/SO₂/CO₂CO/O₂ sensor [Example connection]
 (with converted value and converted average value)

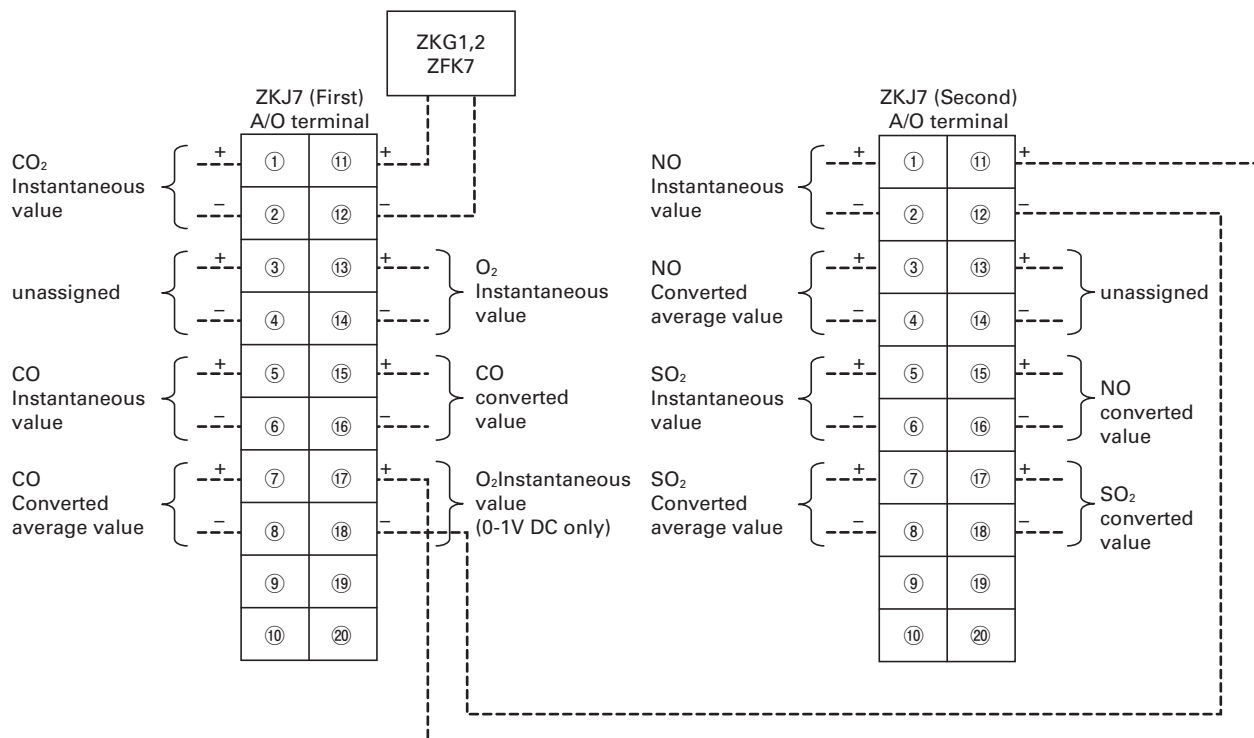

Table 2. Correspondence between measurement channels and measured value

The following table gives measurement channels and their contents according to the code symbols.

1. In case of using only one analyzer.

Code symbol			Contents
5th digit	6th digit	22nd digit	
P	Y	Y	Ch1: NO
A	Y	Y	Ch1: SO ₂
D	Y	Y	Ch1: CO ₂
B	Y	Y	Ch1: CO
E	Y	Y	Ch1: CH ₄
F	Y	Y	Ch1: NO, Ch2: SO ₂
G	Y	Y	Ch1: CO ₂ , Ch2: CO
P	A, B	Y	Ch1: NO, Ch2: O ₂
A	A, B	Y	Ch1: SO ₂ , Ch2: O ₂
D	A, B	Y	Ch1: CO ₂ , Ch2: O ₂
B	A, B	Y	Ch1: CO, Ch2: O ₂
E	A, B	Y	Ch1: CH ₄ , Ch2: O ₂
F	A, B	Y	Ch1: NO, Ch2: SO ₂ , Ch3: O ₂
G	A, B	Y	Ch1: CO ₂ , Ch2: CO, Ch3: O ₂
P	A, B	A	Ch1: NO, Ch2: O ₂ , Ch3: Converted NO, Ch4: Converted NO average
A	A, B	A	Ch1: SO ₂ , Ch2: O ₂ , Ch3: Converted SO ₂ , Ch4: Converted SO ₂ average
B	A, B	A	Ch1: CO, Ch2: O ₂ , Ch3: Converted CO, Ch4: Converted CO average
F	A, B	A	Ch1: NO, Ch2: SO ₂ , Ch3: O ₂ , Ch4: Converted NO, Ch5: Converted SO ₂ , Ch6: Converted NO average, Ch7: Converted SO ₂ average
G	A, B	A	Ch1: CO ₂ , Ch2: CO, Ch3: O ₂ , Ch4: Converted CO, Ch5: Converted CO average

2. In case of using two analyzers installed.

1st analyzer			
Code symbol			Contents
5th digit	6th digit	22nd digit	
B	Y	Y	Ch1: CO
D	Y	Y	Ch1: CO ₂
E	Y	Y	Ch1: CH ₄
G	Y	Y	Ch1: CO ₂ , Ch2: CO
B	Y	Y	Ch1: CO
D	Y	Y	Ch1: CO ₂
E	Y	Y	Ch1: CH ₄
G	Y	Y	Ch1: CO ₂ , Ch2: CO
B	Y	Y	Ch1: CO
D	Y	Y	Ch1: CO ₂
E	Y	Y	Ch1: CH ₄
G	Y	Y	Ch1: CO ₂ , Ch2: CO
B	Y	Y	Ch1: CO
D	Y	Y	Ch1: CO ₂
E	Y	Y	Ch1: CH ₄
G	Y	Y	Ch1: CO ₂ , Ch2: CO
B	Y	Y	Ch1: CO
D	Y	Y	Ch1: CO ₂
E	Y	Y	Ch1: CH ₄
G	Y	Y	Ch1: CO ₂ , Ch2: CO
D	A, B	Y	Ch1: CO ₂
E	A, B	Y	Ch1: CH ₄
D	A, B	Y	Ch1: CO ₂
E	A, B	Y	Ch1: CH ₄
D	A, B	Y	Ch1: CO ₂
E	A, B	Y	Ch1: CH ₄
B	A, B	A	Ch1: CO, Ch2: O ₂ Ch3: Converted CO Ch4: Converted CO average
G	A, B	A	Ch1: CO ₂ , Ch2: CO, Ch3: O ₂ Ch4: Converted CO Ch5: Converted CO average
B	A, B	A	Ch1: CO, Ch2: O ₂ Ch3: Converted CO Ch4: Converted CO average
G	A, B	A	Ch1: CO ₂ , Ch2: CO, Ch3: O ₂ Ch4: Converted CO Ch5: Converted CO average
B	A, B	A	Ch1: CO, Ch2: O ₂ Ch3: Converted CO Ch4: Converted CO average
G	A, B	A	Ch1: CO ₂ , Ch2: CO, Ch3: O ₂ Ch4: Converted CO Ch5: Converted CO average

Second analyzer			
Code symbol			Contents
5th digit	6th digit	22nd digit	
P	Y	Y	Ch1: NO
A	Y	Y	Ch1: SO ₂
F	Y	Y	Ch1: NO, Ch2: SO ₂
P	A, B	Y	Ch1: NO, Ch2: O ₂
A	A, B	Y	Ch1: SO ₂ , Ch2: O ₂
F	A, B	Y	Ch1: NO, Ch2: SO ₂ Ch3: O ₂
P	A, B	A	Ch1: NO Ch2: O ₂ Ch3: Converted NO Ch4: Converted NO average
A	A, B	A	Ch1: SO ₂ Ch2: O ₂ Ch3: Converted SO ₂ Ch4: Converted SO ₂ average
F	A, B	A	Ch1: NO Ch2: SO ₂ Ch3: O ₂ Ch4: Converted NO Ch5: Converted SO ₂ Ch6: Converted NO average Ch7: Converted SO ₂ average
P	D	A	Ch1: NO Ch2: Converted NO Ch3: Converted NO average
A	D	A	Ch1: SO ₂ Ch2: Converted SO ₂ Ch3: Converted SO ₂ average
F	D	A	Ch1: NO Ch2: SO ₂ Ch3: Converted NO Ch4: Converted SO ₂ Ch5: Converted NO average Ch6: Converted SO ₂ average

Example of Code symbol for replacement

[ZRG]

	Component	Example of code symbol
1st analyzer	CO, CO ₂ , O ₂	ZRG6GBB2-0B0ND-FF1F5FY
2nd analyzer	NO, SO ₂ , O ₂	ZRG6FBB2-0B0ND-FF1F5FY



[ZKJ7]

	Component	Example of code symbol
1st analyzer	CO, CO ₂ , O ₂	ZKJ7G[A]14-YJBFB-FYYYY[VY]-CAB ↳ External zirconia O ₂ sensor ↳ O ₂ range 0-25% fixed
2nd analyzer	NO, SO ₂	ZKJ7F[D]14-YJBFB-FYYYYY-CAB ↳ without external O ₂ indication

SCOPE OF DELIVERY

- Gas analyzer ... 1 unit
- Spare fuses (250V, 3.15A AC, delay type) ... 2 pcs
- Instruction manual ... 1 copy

ORDERING INFORMATION

1. Code symbols
2. Application and composition of sample gas

Items to be prepared separately

- Various sampling devices (refer to Data Sheets for the sampling devices)
- Dedicated zirconia O₂ sensor (see Page 16)

Exclusive Zirconia O₂ Sensor (to be purchased separately)

This sensor should be used with ZKJ7.
 Measuring method: Zirconia system
 Measurable component and measuring range:

Measurable component		Range
O ₂	Oxygen	0 to 25vol%

Repeatability: Within ± 0.5% of full scale
 Linearity: Within ± 1% of full scale
 Zero drift: Within ± 1% of full scale/week
 Span drift: Within ± 2% of full scale/week
 Response time: Approx. 20 seconds (for 90% response)
 Measured gas flow rate:
 0.5 ± 0.25L / min

Remark: The Zirconia system, due to its principle, may produce a measuring error due to relative concentration versus the com-bustible O₂ gas concentration. Also, a corrosive gas (SO₂ of 250 ppm or more, etc.) may affect the life of the sensor.

Gas inlet/outlet size: Rc¹/₄ or NPT¹/₄

Power supply: Rated voltage ; 100 to 115V AC or 200 to 240V AC
 Rated frequency ; 50Hz/60Hz
 Max. rated power ; 215VA (during power ON)
 65VA (during steady-state operation)

Enclosure: Steel casing, for indoor application
 Indication: Temperature indication (LED)
 Temperature alarm output:
 Contact output 1a contact,
 Contact capacity 220V, 1A AC (resistive load)

Outer dimensions (H x W x D):
 141 x 170 x 190mm
 Mass {weight}: Approx. 3kg
 Finish color: Munsell 5Y 7/1

CODE SYMBOLS

1	2	3	4	5	6	7	8	9	10	11	12	13	Description
Z	F	K					4	-	Y	0	Y	Y	Measuring method Zirconia method
							7	Y					Power supply 100 to 115V AC 50/60Hz(Standard) 200 to 240V AC 50/60Hz(Standard) 200 to 240V AC 50/60Hz(CE mark)
													Gas inlet/outlet size Rc ¹ / ₄ NPT ¹ / ₄

OUTLINE DIAGRAM (Unit:mm)

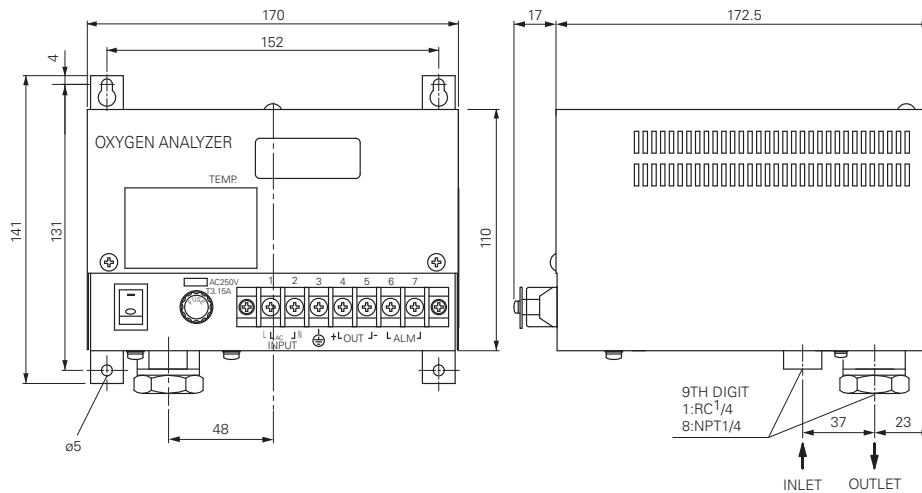

EXTERNAL CONNECTION DIAGRAM

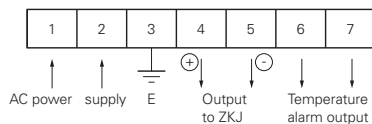

⚠ Caution on Safety

*Before using this product, be sure to read its instruction manual in advance.

Fuji Electric Co., Ltd.

**International Sales Div
Sales Group**

Gate City Ohsaki, East Tower, 11-2, Osaki 1-chome,
Shinagawa-ku, Tokyo 141-0032, Japan

<http://www.fujielectric.com>

Phone: 81-3-5435-7280, 7281 Fax: 81-3-5435-7425

<http://www.fujielectric.com/products/instruments/>