

## General Description

The MIC4467/8/9 family of 4-output CMOS buffer/drivers is an expansion from the earlier single- and dual-output drivers, to which they are functionally closely related. Because package pin count permitted it, each driver has been equipped with a 2-input logic gate for added flexibility. Placing four high-power drivers in a single package also improves system reliability and reduces total system cost. In some applications, one of these drivers can replace not only two packages of single-input drivers, but some of the associated logic as well.

Although primarily intended for driving power MOSFETs, and similar highly capacitive loads, these drivers are equally well suited to driving any other load (capacitive, resistive, or inductive), which requires a high-efficiency, low-impedance driver capable of high peak currents, rail-to-rail voltage swings, and fast switching times. For example, heavily loaded clock lines, coaxial cables, and piezoelectric transducers can all be

## Features

- Built using reliable, low power CMOS processes
- Latchproof. Withstands 500mA Inductive Kickback
- 3 Input Logic Choices
- Symmetrical Rise and Fall Times ..... 25ns
- Short, Equal Delay Times ..... 75ns
- High Peak Output Current ..... 1.2A
- Wide Operating Range ..... 4.5 to 18V
- Low Equivalent Input Capacitance (typ) ..... 6pF
- Inputs = Logic 1 for Any Input From 2.4V to  $V_S$
- ESD Protected

## Applications

- General-Purpose CMOS Logic Buffer
- Driving All 4 MOSFETs in an H-Bridge
- Direct Small-Motor Driver
- Relay or Peripheral Drivers
- Dual Differential Output Power Drivers
- CCD Driver
- Pin-Switching Network Driver

## Logic Diagrams

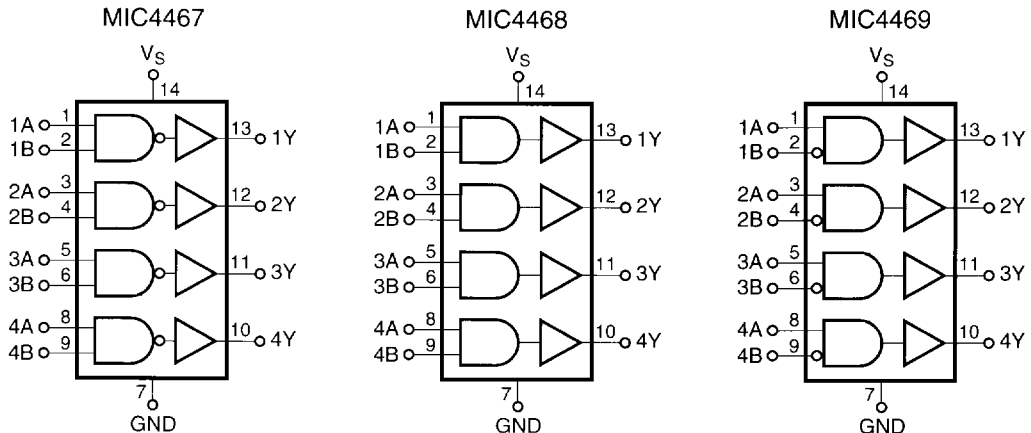

driven easily with MIC446X series drivers. The only limitation on loading is that total power dissipation in the IC must be kept within the power dissipation limits of the package.

The MIC446X series drivers are built using a BCD process. They will not latch under any conditions within their power and

voltage ratings. They are not subject to damage when up to 5V of noise spiking (either polarity) occurs on the ground line. They can accept up to half an amp of inductive kickback current (either polarity) into their outputs without damage or logic upset.

**Ordering Information**

Part No.	Package	Temp. Range
MIC44**CN	14-Pin Plastic DIP	0° to +70°C
MIC44**CWM	16-Pin Wide SOIC	0° to +70°C
MIC44**BN	14-Pin Plastic DIP	-40° to +85°C
MIC44**BWM	16-Pin Wide SOIC	-40° to +85°C
MIC44**BJ	14-Pin CerDIP	-40° to +85°C
MIC44**AJB*	14-Pin CerDIP	-55° to +125°C
MIC44**AL	20-Pin LCC	-55° to +125°C
MIC44**CY	Die	0° to +70°C

\* AJB indicates units screened to MIL-STD 883, Method 5004, condition B, and burned-in for 1-week.

\*\*Two digits must be added in this position to define the device logic:  
 67 — NAND  
 68 — AND  
 69 — AND with one inverting input

**Truth Table**

Part No.	Inputs		Output Y
	A	B	
MIC4467 (Each Driver)	L	X	H
	X	L	H
	H	H	L
MIC4468 (Each Driver)	H	H	H
	L	X	L
	X	L	L
MIC4469 (Each Driver)	L	X	L
	X	H	L
	H	L	H

**Pin Configurations**

14-Pin Dual-In-Line Package - N, J

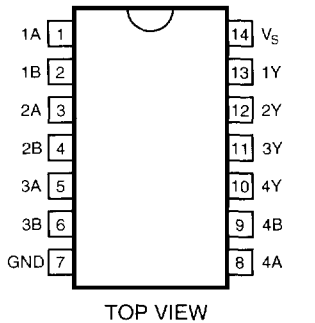

16-Pin Wide SOIC - WM

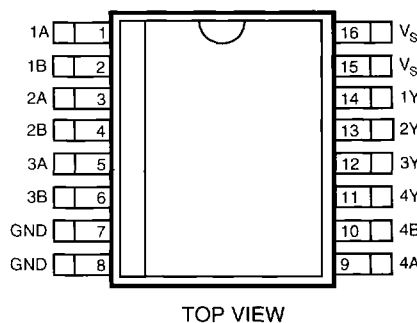

20-Pin LCC - L

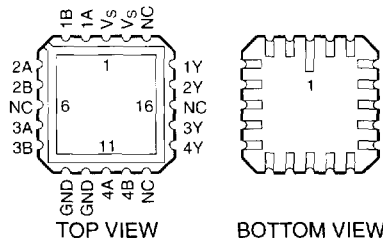

**Absolute Maximum Ratings (Notes 1 and 2)**

Supply Voltage	22V	Power Dissipation	
Input Voltage	(GND – 5V) to (V <sub>S</sub> + 0.3V)	P Package (14-Pin Plastic DIP)	1.5W
Maximum Chip Temperature		WM Package (16-Pin Wide SOIC)	1W
Operating	150°C	J Package (14-Pin CerDIP)	1.25W
Storage	–65° to +150°C	L Package (20-Pin LCC)	1W
Maximum Load Temperature		Package Thermal Resistance	
(10 sec, for soldering)	300°C	P Package (14-Pin Plastic DIP) R <sub>θJ-A</sub>	80°C/W
Operating Ambient Temperature		WM Package (16-Pin Wide SOIC) R <sub>θJ-A</sub>	120°C/W
C Version	0° to +70°C	J Package (14-Pin CerDIP) R <sub>θJ-A</sub>	100°C/W
B Version	–40° to +85°C	L Package (20-Pin LCC) R <sub>θJ-A</sub>	120°C/W
A Version	–55° to +125°C		

**Electrical Characteristics:** Measured at T<sub>A</sub> = 25°C with 4.5V ≤ V<sub>S</sub> ≤ 18V unless otherwise specified.

Symbol	Parameter	Conditions	Min	Typ	Max	Units
<b>INPUT</b>						
V <sub>IH</sub>	Logic 1 Input Voltage		2.4	1.3		V
V <sub>IL</sub>	Logic 0 Input Voltage			1.2	0.8	V
I <sub>IN</sub>	Input Current	0 ≤ V <sub>IN</sub> ≤ V <sub>S</sub>	–1		1	μA
<b>OUTPUT</b>						
V <sub>OH</sub>	High Output Voltage	I <sub>LOAD</sub> = 10mA	V <sub>S</sub> –0.15			V
V <sub>OL</sub>	Low Output Voltage	I <sub>LOAD</sub> = 10mA			0.15	V
R <sub>O</sub>	Output Resistance	I <sub>OUT</sub> = 10mA, V <sub>S</sub> = 18V		5	15	Ω
I <sub>PK</sub>	Peak Output Current			1.2		A
I	Latch-Up Protection Withstand Reverse Current		>500			mA
<b>SWITCHING TIME</b>						
t <sub>R</sub>	Rise Time	Test Figure 1		14	25	ns
t <sub>F</sub>	Fall Time	Test Figure 1		13	25	ns
t <sub>D1</sub>	Delay Time	Test Figure 1		30	75	ns
t <sub>D2</sub>	Delay Time	Test Figure 1		45	75	ns
<b>POWER SUPPLY</b>						
I <sub>S</sub>	Power Supply Current Supply			0.2	4	mA

**Electrical Characteristics:**

Measured over operating temperature range with  $4.5V \leq V_S \leq 18V$  unless otherwise specified.

Symbol	Parameter	Conditions	Min	Typ	Max	Units
<b>INPUT</b>						
$V_{IH}$	Logic 1 Input Voltage		2.4	1.4		V
$V_{IL}$	Logic 0 Input Voltage			1.0	0.8	V
$I_{IN}$	Input Current	$0 \leq V_{IN} \leq V_S$	-1		1	$\mu A$
<b>OUTPUT</b>						
$V_{OH}$	High Output Voltage	$I_{LOAD} = 10 \text{ mA}$	$V_S - 0.3$			V
$V_{OL}$	Low Output Voltage	$I_{LOAD} = 10 \text{ mA}$			0.3	V
$R_O$	Output Resistance	$I_{OUT} = 10 \text{ mA}, V_S = 18V$		7	30	$\Omega$
$I_{PK}$	Peak Output Current			1.2		A
I	Latch-Up Protection Withstand Reverse Current		500			mA
<b>SWITCHING TIME</b>						
$t_R$	Rise Time	Test Figure 1		17	50	ns
$t_F$	Fall Time	Test Figure 1		16	50	ns
$t_{D1}$	Delay Time	Test Figure 1		35	100	ns
$t_{D2}$	Delay Time	Test Figure 1		55	100	ns
<b>POWER SUPPLY</b>						
$I_S$	Power Supply Current Supply			0.4	8	mA

**NOTE 1:** Functional operation above the absolute maximum stress ratings is not implied.

**NOTE 2:** Static sensitive device. Store only in conductive containers. Handling personnel and equipment should be grounded to prevent static damage.

5

# Typical Characteristics

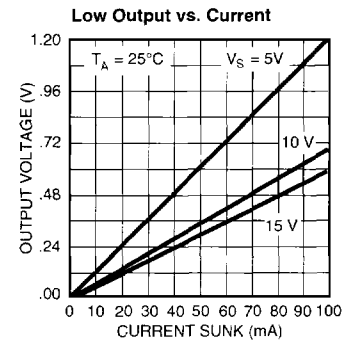
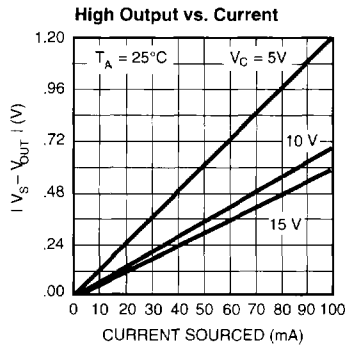
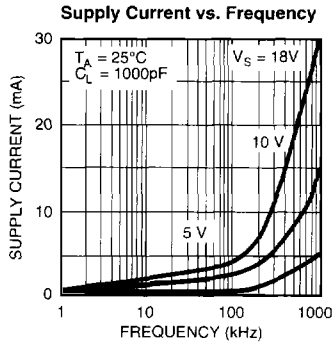
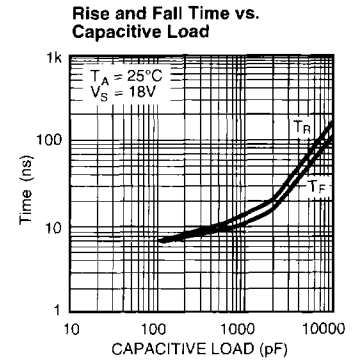
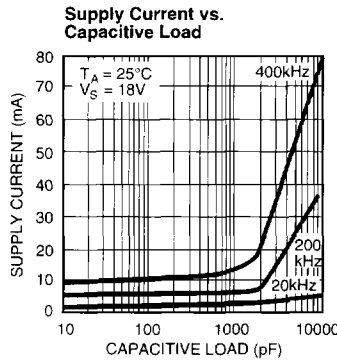
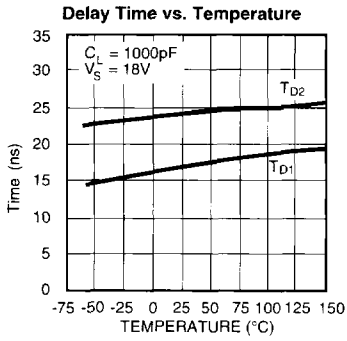
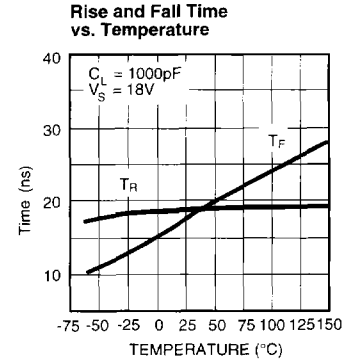
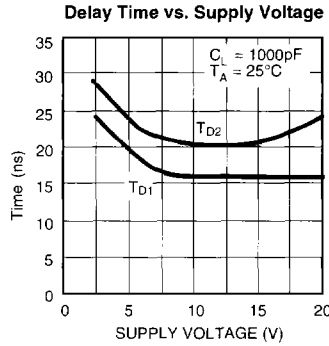
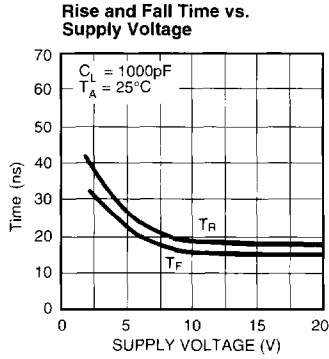

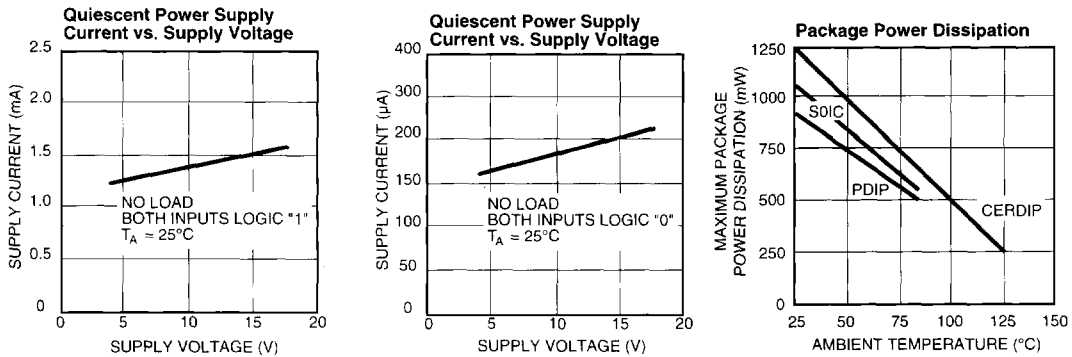

Test Figure 1

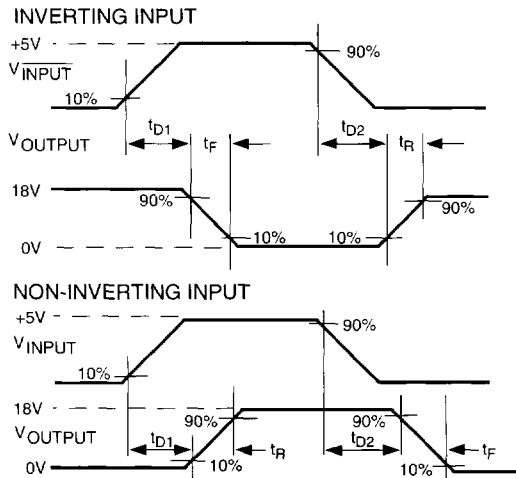
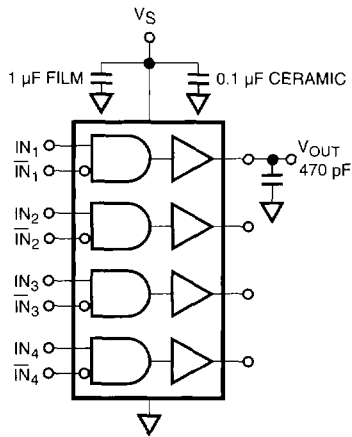

5

Package Power Dissipation

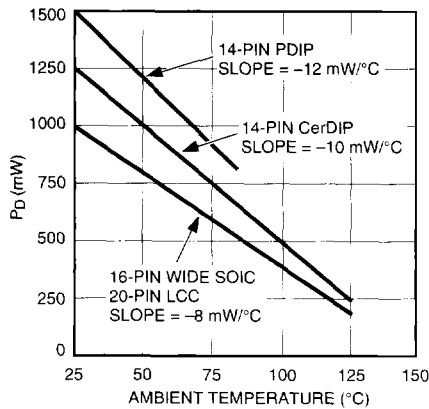

Quad Driver Drives H Bridge to Control Motor Speed and Direction

