

WDM COMPONENTS

COARSE WDM

DiCon's Coarse WDM is designed to multiplex and demultiplex signals in metropolitan, access, and enterprise networks. Coarse WDMs are low cost components for systems with fewer than eight channels and feature wide 13 nm channel passbands to accommodate variations in laser center wavelengths over temperature.



FEATURES

- Channel plans based on 20 nm channel spacing
- High isolation for demultiplexing applications
- Low insertion loss
- Tested to Telcordia GR-1221

APPLICATIONS

Coarse WDMs multiplex and demultiplex signals in systems based on an emerging industry standard grid with 20 nm channel spacings. These systems use uncooled lasers and low cost Coarse WDM components as an alternative to more expensive components based on 100 GHz or 200 GHz channel plans.



WDM COMPONENTS

SPECIFICATIONS¹

Channel spacing	20 nm
Passband C - P1 ²	13 nm min.
Insertion loss C - P1	0.6 dB typ., 1.0 dB max.
Insertion loss C - P2	0.6 dB max.
Isolation C - P1	25 dB min.
Isolation C - P2	10 dB min.
Directivity	55 dB min.
Back-reflection	-45 dB max.
PDL	0.05 dB typ., 0.1 dB max.
Optical power	300 mW max.
Fiber type	9/125 Corning SMF-28
Operating temperature	0°C to +65°C
Storage temperature	-40°C to +85°C

1. All specifications referenced without connectors.
2. Other passbands available by request.

HOUSING DIMENSIONS¹

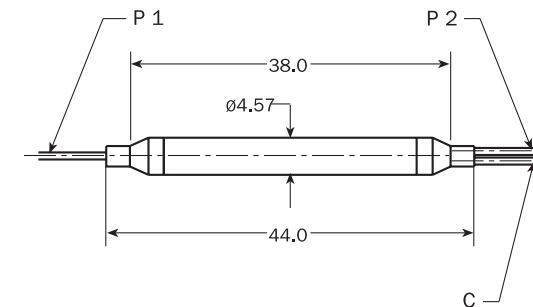

Units: mm
1. Optional 38 or 40 mm housing lengths by request.

ORDERING INFORMATION

CWDM CWL		CW2- [] - [] - [] - []	
01	1431		
02	1451		
03	1471		
04	1491		
05	1511		
06	1531		
07	1551		
08	1571		
09	1591		
10	1611		
Connector Type			
FC	FC/SPC		
FC/APC	FC/APC		
FC/UPC	FC/UPC		
SC	SC/SPC		
SC/APC	SC/APC		
SC/UPC	SC/UPC		
ST	ST/SPC		
ST/UPC	ST/UPC		
LC	LC/SPC		
LC/UPC	LC/UPC		
MU/UPC	MU/UPC		
N	None		
Fiber Jacket			
2	250 micron, 200 kpsi bare fiber		
9	900 micron, tight buffer		
Pigtail Length			
1	1 meter		
X	Specify X meters		