

# KR CONNECTOR

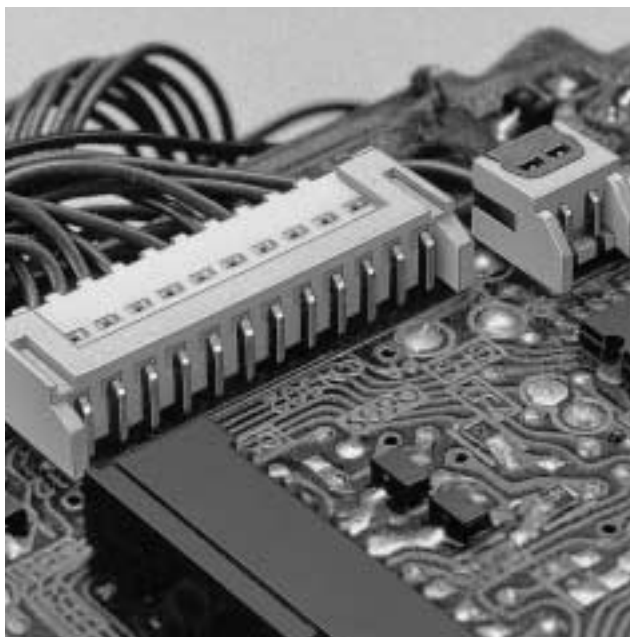

Disconnectable Insulation displacement connectors



**The KR connector features a mounting height as low as 6.9mm (.272") and a thickness as thin as 4.8mm (.189") (for top entry type). It is suitable for interconnection of a wide range of electronic equipment such as VCRs, video cameras, car stereo systems and communication equipment.**

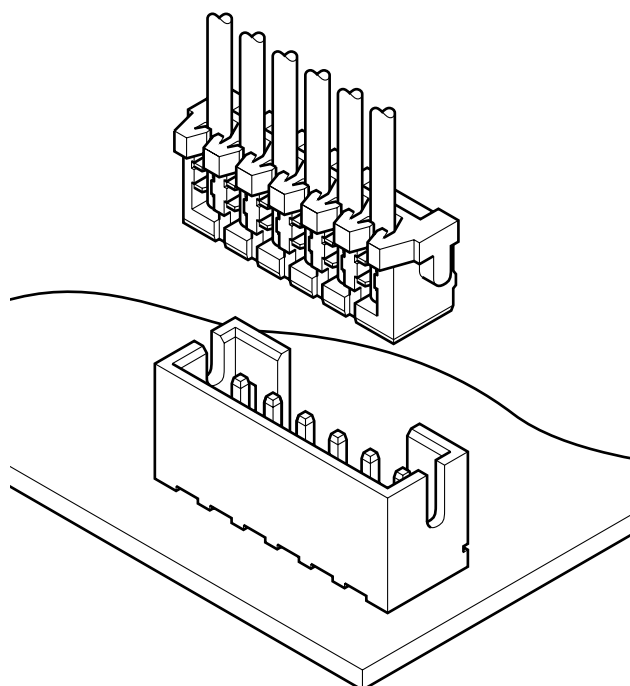

## Features

### • **Folded beam double-leaf contact construction**

The contact springs are folded to increase their effective strength. This design provides a safety margin that allows the contacts to endure the distortion of misinsertion without being permanently distorted.

### • **Twin U-slot insulation displacement section**

The insulation displacement section connected to the wire consists of two tin-plated slots (twin U-slot) for superb reliability.

### • **Strain relief**

The strain relief feature prevents stress due to vibration, impact or bending from effecting the insulation displacement connection. This is accomplished by holding the outside of the wire with the insulation gripping device on the housing. To ensure circuit integrity against vibration and undue tension, ample clearance is provided between the insulation displacement connection and the strain relief.

### • **Compatible with the PH crimp style connector**

The same shrouded header can be used for either PH crimp style connector or KR insulation displacement connector. This allows both types of connector to be used interchangeably without replacing the header.

### • **Surface mount model (SMT)**

This connector is also available in a surface mount configuration. Its housing is made of heat resistant resin so that it is not adversely affected during reflow soldering. Because of its tiny size and ability to be surface mounted, this connector meets the demand for high-density mounting of components inside electronic products.

## Specifications

- Current rating: 1.0A AC, DC (AWG #26)
  - Voltage rating: 100V AC, DC
  - Temperature range: -25°C to +85°C  
(including temperature rise in applying electrical current)
  - Contact resistance: Initial value/10m max.  
After environmental testing/20m max.
  - Insulation resistance: 1,000M min.
  - Withstanding voltage: 800V AC/minute
  - Applicable wire: UL1571, 1061 (Contact JST regarding other UL styles.)  
AWG #28 to #26  
Conductor/7 strands, tin-coated  
Insulation O.D./0.9 to 1.0mm(.035" to .039")  
(The standard applicable wire for connectors having 13 circuits or more is UL 1061.)
  - Applicable panel thickness: 0.8 to 1.6mm(.031" to .063")
- \* Contact JST for details.

## Standards

Recognized E60389

Certified LR20812

R75088

# KR CONNECTOR

## Receptacle

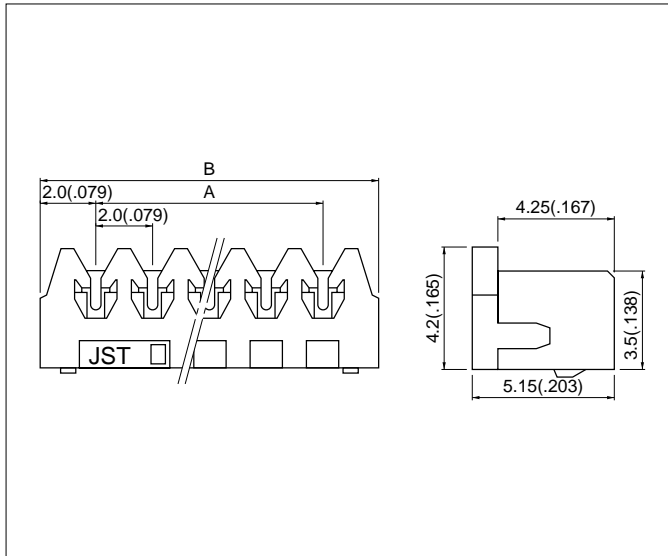

Circuits	Model No.		Dimensions mm(in.)		Q'ty / box
	AWG #28 (green)	AWG #26 (natural/white)	A	B	
2	<b>02KR-8M</b>	<b>02KR-6S</b>	2.0(.079)	6.0(.236)	2,000
3	<b>03KR-8M</b>	<b>03KR-6S</b>	4.0(.157)	8.0(.315)	2,000
4	<b>04KR-8M</b>	<b>04KR-6S</b>	6.0(.236)	10.0(.394)	2,000
5	<b>05KR-8M</b>	<b>05KR-6S</b>	8.0(.315)	12.0(.472)	2,000
6	<b>06KR-8M</b>	<b>06KR-6S</b>	10.0(.394)	14.0(.551)	2,000
7	<b>07KR-8M</b>	<b>07KR-6S</b>	12.0(.472)	16.0(.630)	2,000
8	<b>08KR-8M</b>	<b>08KR-6S</b>	14.0(.551)	18.0(.709)	1,000
9	<b>09KR-8M</b>	<b>09KR-6S</b>	16.0(.630)	20.0(.787)	1,000
10	<b>10KR-8M</b>	<b>10KR-6S</b>	18.0(.709)	22.0(.866)	1,000
11	<b>11KR-8M</b>	<b>11KR-6S</b>	20.0(.787)	24.0(.945)	1,000
12	<b>12KR-8M</b>	<b>12KR-6S</b>	22.0(.866)	26.0(1.024)	1,000
13	<b>13KR-8M</b>	<b>13KR-6S</b>	24.0(.945)	28.0(1.102)	1,000
14	<b>14KR-8M</b>	<b>14KR-6S</b>	26.0(1.024)	30.0(1.181)	500
15	<b>15KR-8M</b>	<b>15KR-6S</b>	28.0(1.102)	32.0(1.260)	500
16	<b>16KR-8M</b>	<b>16KR-6S</b>	30.0(1.181)	34.0(1.339)	500

### Material and Finish

Contact: Phosphor bronze, copper-undercoated, tin/lead-plated  
 Housing: 2 to 12 circuits/Nylon 66, UL94V-0  
 13 to 16 circuits/Glass-filled nylon 66, UL94V-0

## Through-hole type shrouded header

The shrouded headers are interchangeable with those of the PH crimp style connectors and with KR and CR insulation displacement connectors.

## Through-hole type PC board layout (viewed from soldering side) and Assembly layout

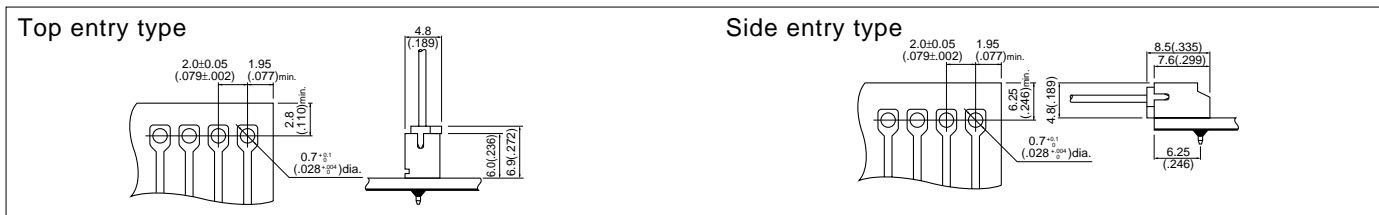

Note: 1. Tolerances are non-cumulative:  $\pm 0.05\text{mm} (\pm 0.002")$  for all centers.

2. Hole dimensions differ according to the kind of PC board and piercing method. If PC board are made of hard material such as FR-4 are used, the hole dimensions should be larger. The hole dimensions above should serve as a guideline.

Contact JST for details.

## SMT type shrouded header

The shrouded headers are interchangeable with those of the PH crimp style connectors and CRand KRd insulation displacement connectors.

## SMT type PC board layout (viewed from component side) and Assembly layout

