

THIS COPY IS PROVIDED ON A RESTRICTED BASIS AND IS NOT TO BE USED IN ANY WAY DETRIMENTAL TO THE INTERESTS OF PANDUIT CORP.

PANDUIT PART NUMBER	STUD SIZE	DIMENSIONS in.				
		A ±.040	W ±.010	C ±.020	M ±.040	H ±.010
PNF10-6F-2K	#6	1.01 (25.65)	.31 (7.87)	.24 (6.10)	.80 (20.32)	.15 (3.81)
PNF10-8F-2K	#8	1.02 (25.91)	.37 (9.40)	.24 (6.10)	.80 (20.32)	.17 (4.32)
PNF10-10F-2K	#10	1.04 (26.42)	.37 (9.40)	.22 (5.59)	.80 (20.32)	.20 (5.08)
PNF10-14F-2K	1/4"	1.15 (29.21)	.49 (12.45)	.32 (8.13)	.90 (22.86)	.27 (6.86)

NOTES :

- UL LISTED AND CSA CERTIFIED FOR :
 - 600 V MAX. VOLTAGE RATING
 - 221°F (105°C) MAX. TEMP. RATING
 - #12-10 AWG (2.5-6.0 mm²) SOLID OR STRANDED, COPPER WIRE
- PACKAGE QTY. : 2K = 2000 PCS.
CONTINUOUS MOLDED CARRIER STRIP
- MATERIAL :
 - STAMPING - .04" THK COPPER, TIN PLATED
 - HOUSING - YELLOW NYLON
 - SLEEVE - BRASS, TIN PLATED
- DIMENSIONS IN BRACKETS ARE IN MILLIMETERS
- INSTALLATION TOOLS :
 - PRESSES - CP-851, CP-860, CP-861
 - APPLICATOR - CA-800
 - DIE INSERTS - CD-800-3
- WIRE STRIP LENGTH: $11/32^{+1/32}$ (8.7^{+0.8}₋₀)

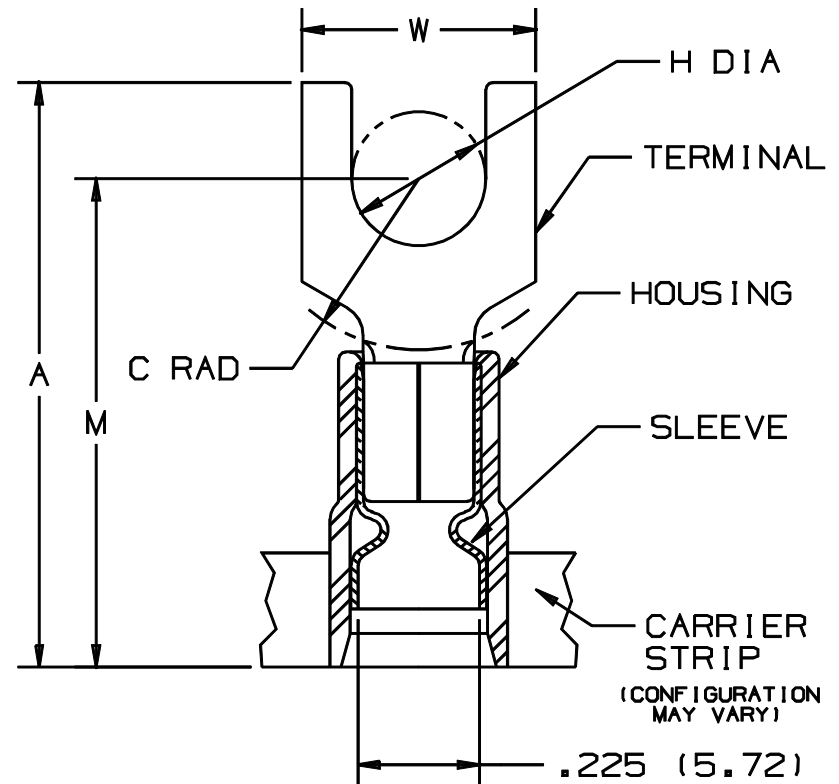

.225 (5.72)
MAX WIRE
INSUL DIA
.135 (3.43)
MIN. WIRE
INSUL. DIA.

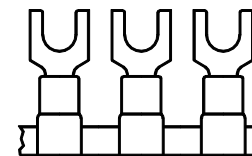

A41139_05

05	2/00	ED		FILESPEC WAS: N41139AA_PCD_04						<p>TINLEY PARK, ILLINOIS</p> <p>TERMO 3PC, CONTINUOUSLY MOLDED NYLON (FUNNEL) INSULATED, 12-10 BARREL, FORKS</p>		
04	5/99	ED		UPDATED "A" & "M" DIM.S, AND MODIFIED DIMENSIONAL TOLERANCES								
03	1/97	JAMB	RLS	ADDED DIM., "MIN. WIRE INSULATION DIA."	05442	LA	DBH					
REV	DATE	BY	CHK	DESCRIPTION	ECN	QA	CUST	PM	DRAWN BY GRM	CHK'D FS	SCALE NONE	DRAWING NO. A41139