

**2.5V 20-Bit Bus Interface
Flip-Flop with 3-State Outputs**

Product Features

- PI74AVC+16821 is designed for low-voltage operation, $V_{CC} = 1.65V$ to $3.6V$
- True $\pm 24mA$ Balanced Drive @ $3.3V$
- I_{OFF} supports partial power-down operation
- $3.6V$ I/O Tolerant Inputs and Outputs
- All outputs contain a patented DDC (Dynamic Drive Control) circuit that reduces noise without degrading propagation delay
- Industrial operation: $-40^{\circ}C$ to $+85^{\circ}C$
- Available Packages:
 - 56-pin 240 mil wide plastic TSSOP (A)
 - 56-pin 173 mil wide plastic TVSOP (K)

Description

Pericom Semiconductor's PI74AVC+ series of logic circuits are produced using the Company's advanced submicron CMOS technology, achieving industry leading speed.

The PI74AVC+ 16821 is a 20-bit bus interface flip-flop designed for $1.65V$ to $3.6V$ V_{CC} operation. It can be used as two 10-bit flip-flops or one 20-bit flip-flop. The 20 flip-flops are edge-triggered D-type flip-flops. On the positive transition of the clock (CLK) input, the device provides true data at the Q outputs.

A buffered output-enable (\overline{OE}) input can be used to place the ten outputs in either a normal logic state (HIGH or LOW level) or a high-impedance state. In the high-impedance state, the outputs neither load nor drive the bus lines significantly. The high-impedance state and increased drive provide the capacity to drive bus lines without the need for interface or pullup components.

\overline{OE} does not affect the internal operation of the flip-flops. Old data can be retained or new data can be entered while the outputs are in the high-impedance state.

To ensure the high-impedance state during power up or power down, \overline{OE} should be tied to V_{CC} through a pullup resistor; the minimum value of the resistor is determined by the current sinking capability of the driver.

Logic Block Diagram

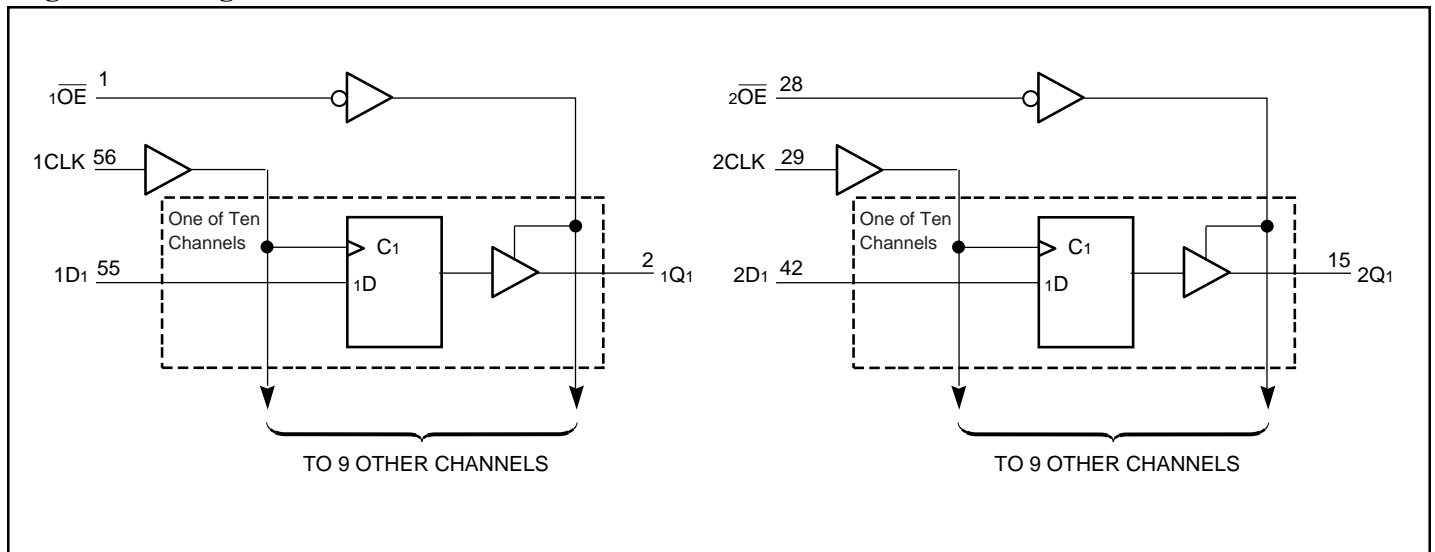

Pin Description

Pin Name	Description
\overline{OE}	Output Enable Input (Active LOW)
CLK	Clock Input (Active HIGH)
Dx	Data Inputs
Qx	3-State Outputs
GND	Ground
VCC	Power

Truth Table⁽¹⁾

Inputs			Outputs
\overline{OEn}	CLK	D	Qn
L	↑	H	H
L	↑	L	L
L	H OR L	X	Q0
H	X	X	Z

Note:

1. H = High Signal Level
- L = Low Signal Level
- X = Irrelevant
- Z = High Impedance
- ↑ = LOW-to-HIGH Transition
- n = 1,2

Pin Configuration

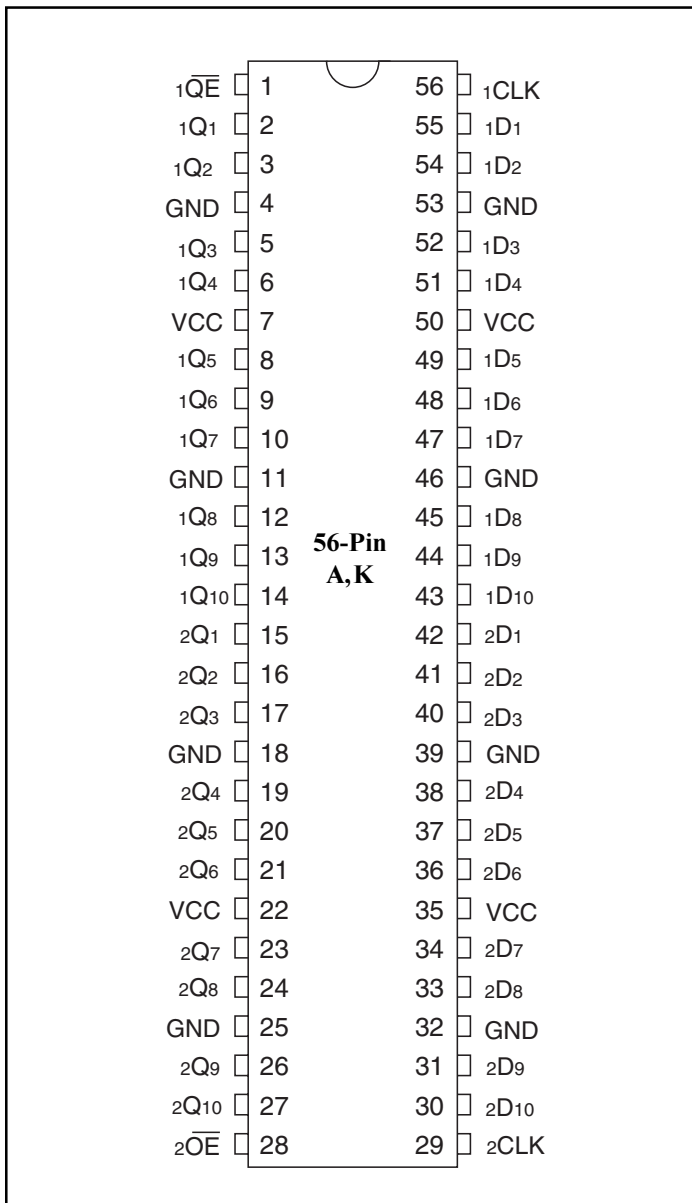

Maximum Ratings

(Above which useful life may be impaired. For user guidelines, not tested.)

Supply voltage range, V_{CC}	-0.5V to +4.6V
Input voltage range, V_I	-0.5V to +4.6V
Voltage range applied to any output in the high-impedance or power-off state, $V_O^{(1)}$	-0.5V to +4.6V
Voltage range applied to any output in the high or low state, $V_O^{(1,2)}$	-0.5V to $V_{CC}+0.5V$
Input clamp current, $I_{IK} (V_I < 0)$	-50mA
Output clamp current, $I_{OK} (V_O < 0)$	-50mA
Continuous output current, I_O	$\pm 50mA$
Continuous current through each V_{CC} or GND	$\pm 100mA$
Package thermal impedance, $\theta_{JA}^{(3)}$: Package A	64°C/W
Package K	48°C/W
Storage Temperature range, T_{stg}	-65°C to 150°C

Note:

Stresses greater than those listed under MAXIMUM RATINGS may cause permanent damage to the device. This is a stress rating only and functional operation of the device at these or any other conditions above those indicated in the operational sections of this specification is not implied. Exposure to absolute maximum rating conditions for extended periods may affect reliability.

Notes:

1. Input & output negative-voltage ratings may be exceeded if the input and output current rating are observed.
2. Output positive-voltage rating may be exceeded up to 4.6V maximum if the output current rating is observed.
3. The package thermal impedance is calculated in accordance with JESD 51.

Recommended Operating Conditions⁽¹⁾

		Min.	Max.	Units
V_{CC} Supply Voltage	Operating	1.65	3.6	V
	Data retention only	1.2		
V_{IH} High-level Input Voltage	$V_{CC} = 1.2V$	V_{CC}		
	$V_{CC} = 1.65V$ to $1.95V$	$0.65 \times V_{CC}$		
	$V_{CC} = 2.3V$ to $2.7V$	1.7		
	$V_{CC} = 3V$ to $3.6V$	2		
V_{IL} Low-level Input Voltage	$V_{CC} = 1.2V$		GND	
	$V_{CC} = 1.65V$ to $1.95V$		$0.35 \times V_{CC}$	
	$V_{CC} = 2.3V$ to $2.7V$		0.7	
	$V_{CC} = 3V$ to $3.6V$		0.8	
V_I Input Voltage		0	3.6	
V_O Output Voltage	Active State	0	V_{CC}	
	3-State	0	3.6	
I_{OH} High-level output current	$V_{CC} = 1.65V$ to $1.95V$		-6	mA
	$V_{CC} = 2.3V$ to $2.7V$		-12	
	$V_{CC} = 3V$ to $3.6V$		-24	
I_{OL} Low-level output current	$V_{CC} = 1.65V$ to $1.95V$		6	
	$V_{CC} = 2.3V$ to $2.7V$		12	
	$V_{CC} = 3V$ to $3.6V$		24	
DtDv Input transition rise or fall rate	$V_{CC} = 1.65V$ to $3.6V$		5	ns/V
T_A Operating free-air temperature		-40	85	°C

Notes:

1. All unused inputs must be held at V_{CC} or GND to ensure proper device operation.

DC Electrical Characteristics (Over the Operating Range, $T_A = -40^\circ\text{C} + 85^\circ\text{C}$)

Parameters		Test Conditions ⁽¹⁾	V _{CC}	Min.	Max.	Units
V _{OH}		I _{OH} = -100μA	1.65V to 3.6V	V _{CC} - 0.2V		V
		I _{OH} = -6mA V _{IH} = 1.07V	1.65V	1.2		
		I _{OH} = -12mA V _{IH} = 1.7V	2.3V	1.75		
		I _{OH} = -24mA V _{IH} = 2V	3V	2.0		
V _{OL}		I _{OL} = 100μA	1.65V to 3.6V		0.2	V
		I _{OL} = 6mA V _{IH} = 0.57V	1.65V		0.45	
		I _{OL} = 12mA V _{IH} = 0.7V	2.3V		0.55	
		I _{OL} = 24mA V _{IH} = 0.8V	3V		0.8	
I _I		V _I = V _{CC} or GND	3.6V		±2.5	μA
I _{OFF}		V _I or V _O = 3.6V	0		±10	
I _{OZ}		V _I = V _{CC} or GND	3.6V		±10	
I _{CC}		V _O = V _{CC} or GND I _O = 0	3.6V		40	
C _I	Control Inputs	V _I = V _{CC} or GND	2.5V		4	pF
			3.3V		4	
	Data Inputs		2.5V		6	
			3.3V		6	
C _O	Outputs	V _O = V _{CC} or GND	2.5V		8	
			3.3V		8	

Note:

1. Typical values are measured at $T_A = 25^\circ\text{C}$.

Timing requirements

(Over recommended operating free-air temperature range, unless otherwise noted, see Figures 1 thru 4)

	V _{CC} = 1.2V		V _{CC} = 1.5V ± 0.1V		V _{CC} = 1.8V ± 0.15V		V _{CC} = 2.5V ± 0.2V		V _{CC} = 3.3V ± 0.3V		Units
	Min.	Max.	Min.	Max.	Min.	Max.	Min.	Max.	Min.	Max.	
f _{clock} Clock frequency						160		200		200	ns
t _w Pulse duration, CLK high or low					3.1		2.5		2.5		
t _{su} Setup time, data before CLK-	4.1		2.7		2.1		1.5		1.4		
t _h Hold time, data after CLK-	1.7		1.3		1.0		1.0		1.0		

Switching Characteristics

(Over recommended operating free-air temperature range, unless otherwise noted, see Figures 1 thru 4)

Parameters	From (Input)	To (Output)	V _{CC} = 1.2V		V _{CC} = 1.5V ± 0.1V		V _{CC} = 1.8V ± 0.15V		V _{CC} = 2.5V ± 0.2V		V _{CC} = 3.3V ± 0.3V		Units
			Typ.	Min.	Max.	Min.	Max.	Min.	Max.	Min.	Max.		
f _{max}						160		200		200		ns	
t _{pd}	CLK	Q	6.8	1.5	4.5	1.2	4.0	0.8	3.2	0.7	2.8		
t _{en}	$\overline{\text{OE}}$	Q	6.8	1.6	4.5	1.6	4.0	0.9	3.3	0.7	3.0		
t _{dis}	$\overline{\text{OE}}$	Q	5.4	2.5	4.2	2.3	3.6	1	3.4	1.5	3.4		

Operating Characteristics, T_A=25°C

Parameters		Test Conditions	V _{CC} = 1.8V ±0.15V	V _{CC} = 2.5V ±0.2V	V _{CC} = 3.3V ±0.3V	Units
			Typical	Typical	Typical	
C _{pd} Power Dissipation Capacitance	Outputs Enabled	C _L = 0pF, f = 10 MHz	90	100	110	pF
	Outputs Disabled		66	72	78	

PARAMETER MEASUREMENT INFORMATION

$V_{CC} = 1.2V$ and $1.5V \pm 0.1V$

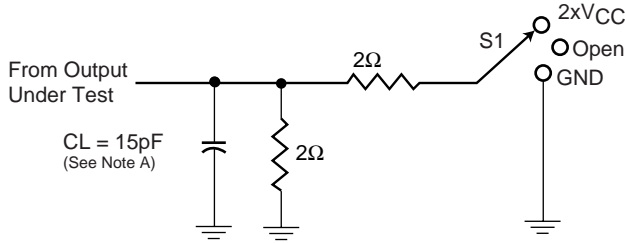

Load Circuit

Test	S1
t_{pd} t_{PLZ}/t_{PZL} t_{PHZ}/t_{PZH}	Open $2 \times V_{CC}$ GND

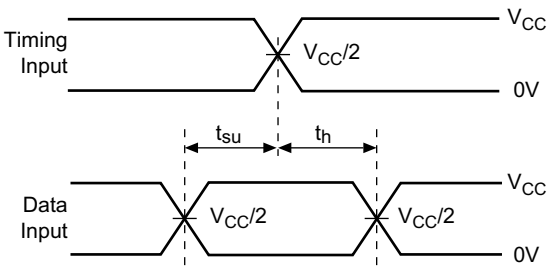

Voltage Waveforms
Setup and Hold Times

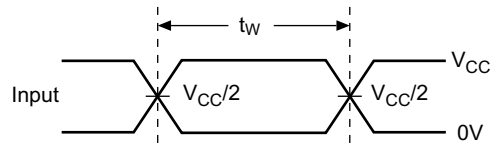

Voltage Waveforms
Pulse Duration

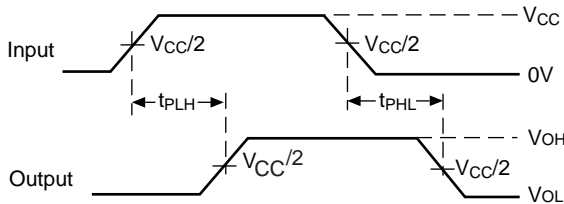

Voltage Waveforms
Propagation Delay Times

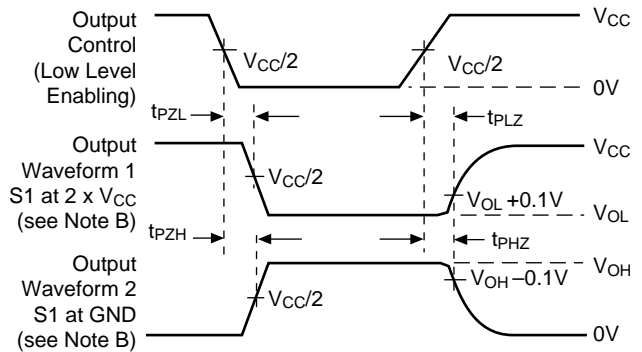

Voltage Waveforms
Enable and Disable Times

Figure 1. Load Circuit and Voltage Waveforms

Notes:

- A. C_L includes probe and jig capacitance.
- B. Waveform 1 is for an output with internal conditions such that the output is low except when disabled by the output control. Waveform 2 is for an output with internal conditions such that the output is high except when disabled by the output control.
- C. All input impulses are supplied by generators having the following characteristics: $PRR \leq 10$ MHz, $Z_O = 50\Omega$, $t_R \leq 2.0ns$, $t_F \leq 2.0ns$.
- D. The outputs are measured one at a time with one transition per measurement.
- E. t_{PLZ} and t_{PHZ} are the same as t_{dis}
- F. t_{PZL} and t_{PZH} are the same as t_{en}
- G. t_{PLH} and t_{PHL} are the same as t_{pd}

PARAMETER MEASUREMENT INFORMATION

$V_{CC} = 1.8V \pm 0.15V$

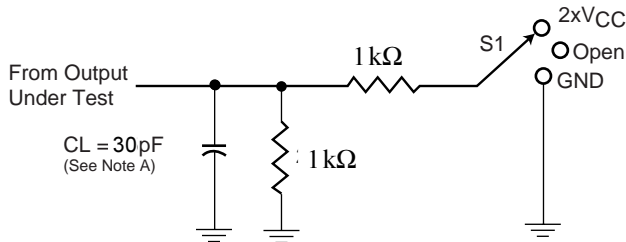

Load Circuit

Test	S1
t_{pd} t_{PLZ}/t_{PZL} t_{PHZ}/t_{PZH}	Open $2 \times V_{CC}$ GND

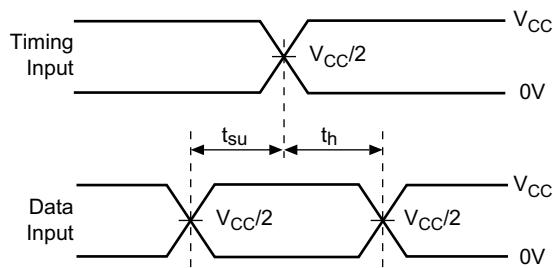

Voltage Waveforms
Setup and Hold Times

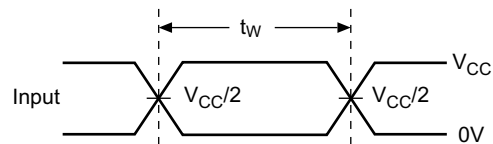

Voltage Waveforms
Pulse Duration

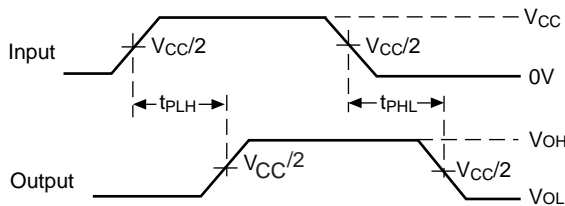

Voltage Waveforms
Propagation Delay Times

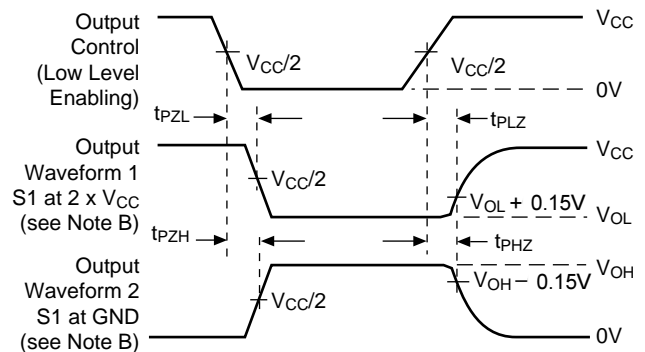

Voltage Waveforms
Enable and Disable Times

Figure 2. Load Circuit and Voltage Waveforms

Notes:

- A. C_L includes probe and jig capacitance.
- B. Waveform 1 is for an output with internal conditions such that the output is low except when disabled by the output control. Waveform 2 is for an output with internal conditions such that the output is high except when disabled by the output control.
- C. All input impulses are supplied by generators having the following characteristics: $PRR \leq 10 \text{ MHz}$, $Z_O = 50\Omega$, $t_R \leq 2.0ns$, $t_F \leq 2.0ns$.
- D. The outputs are measured one at a time with one transition per measurement.
- E. t_{PLZ} and t_{PHZ} are the same as t_{dis}
- F. t_{PZL} and t_{PZH} are the same as t_{en}
- G. t_{PLH} and t_{PHL} are the same as t_{pd}

PARAMETER MEASUREMENT INFORMATION

$V_{CC} = 2.5V \pm 0.2V$

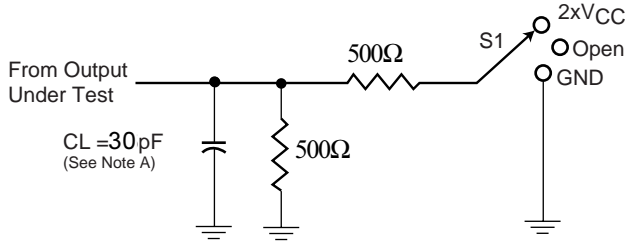

Load Circuit

Test	S1
t_{pd} t_{PLZ}/t_{PZL} t_{PHZ}/t_{PZH}	Open $2 \times V_{CC}$ GND

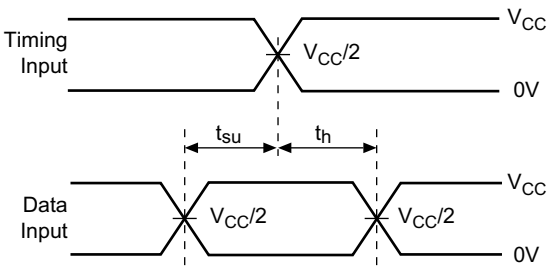

**Voltage Waveforms
Setup and Hold Times**

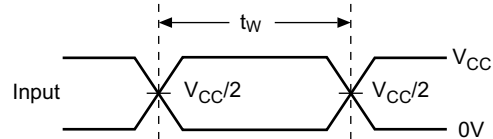

**Voltage Waveforms
Pulse Duration**

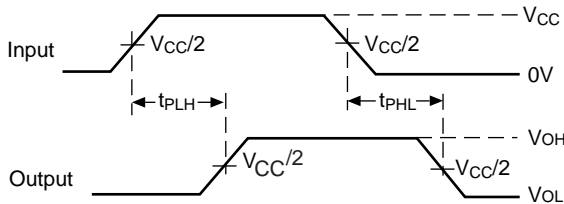

**Voltage Waveforms
Propagation Delay Times**

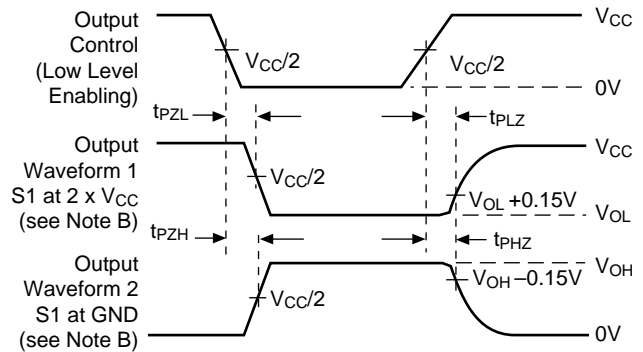

**Voltage Waveforms
Enable and Disable Times**

Figure 3. Load Circuit and Voltage Waveforms

Notes:

- A. C_L includes probe and jig capacitance.
- B. Waveform 1 is for an output with internal conditions such that the output is low except when disabled by the output control. Waveform 2 is for an output with internal conditions such that the output is high except when disabled by the output control.
- C. All input impulses are supplied by generators having the following characteristics: $PRR \leq 10 \text{ MHz}$, $Z_O = 50\Omega$, $t_R \leq 2.0\text{ns}$, $t_F \leq 2.0\text{ns}$.
- D. The outputs are measured one at a time with one transition per measurement.
- E. t_{PLZ} and t_{PHZ} are the same as t_{dis}
- F. t_{PZL} and t_{PZH} are the same as t_{en}
- G. t_{PLH} and t_{PHL} are the same as t_{pd}

PARAMETER MEASUREMENT INFORMATION

$V_{CC} = 3.3V \pm 0.3V$

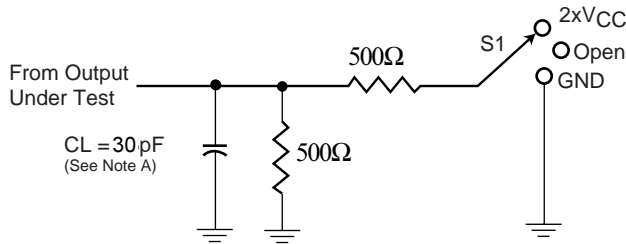

Load Circuit

Test	S1
t_{pd} t_{PLZ}/t_{PZL} t_{PHZ}/t_{PZH}	Open $2 \times V_{CC}$ GND

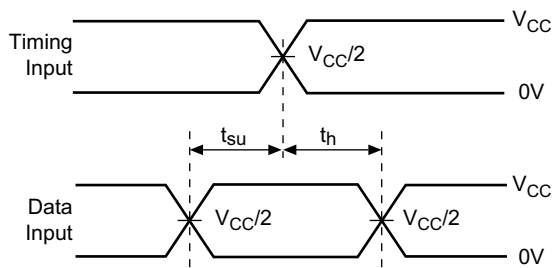

**Voltage Waveforms
Setup and Hold Times**

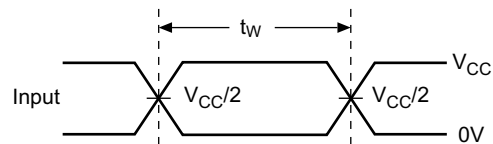

**Voltage Waveforms
Pulse Duration**

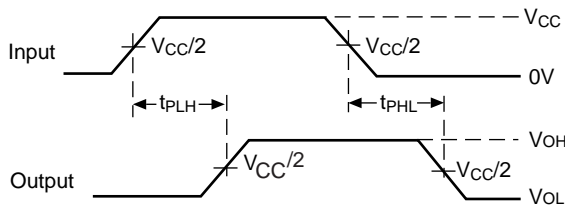

**Voltage Waveforms
Propagation Delay Times**

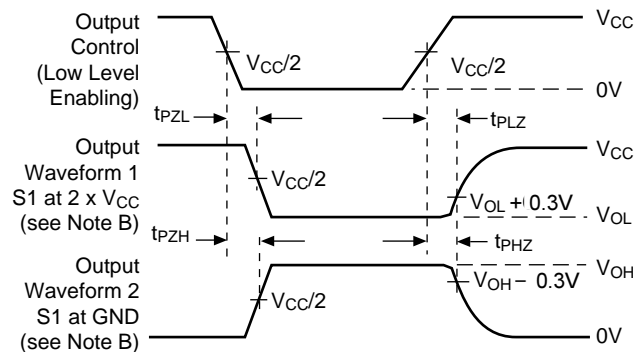

**Voltage Waveforms
Enable and Disable Times**

Figure 4. Load Circuit and Voltage Waveforms

Notes:

- A. C_L includes probe and jig capacitance.
- B. Waveform 1 is for an output with internal conditions such that the output is low except when disabled by the output control.
Waveform 2 is for an output with internal conditions such that the output is high except when disabled by the output control.
- C. All input impulses are supplied by generators having the following characteristics: $PRR \leq 10 \text{ MHz}$, $Z_O = 50\Omega$, $t_R \leq 2.0\text{ns}$, $t_F \leq 2.0\text{ns}$.
- D. The outputs are measured one at a time with one transition per measurement.
- E. t_{PLZ} and t_{PHZ} are the same as t_{dis}
- F. t_{PZL} and t_{PZH} are the same as t_{en}
- G. t_{PLH} and t_{PHL} are the same as t_{pd}

56-pin TSSOP (A) Package

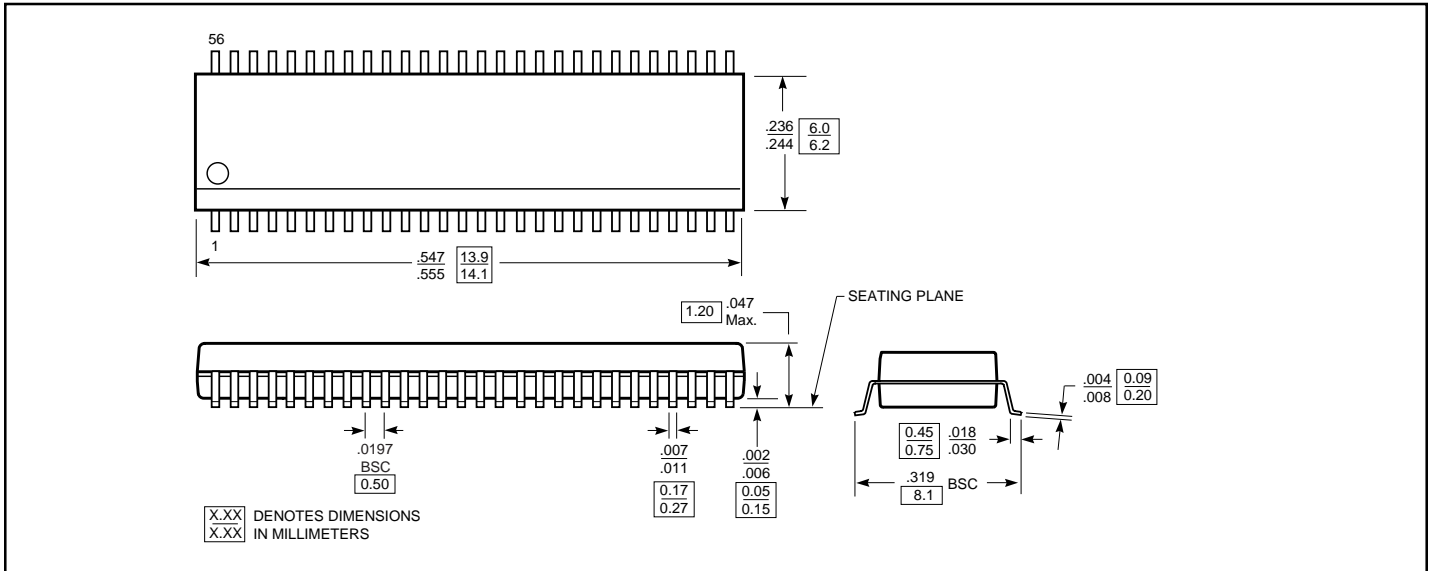

56-pin TVSOP (K) Package

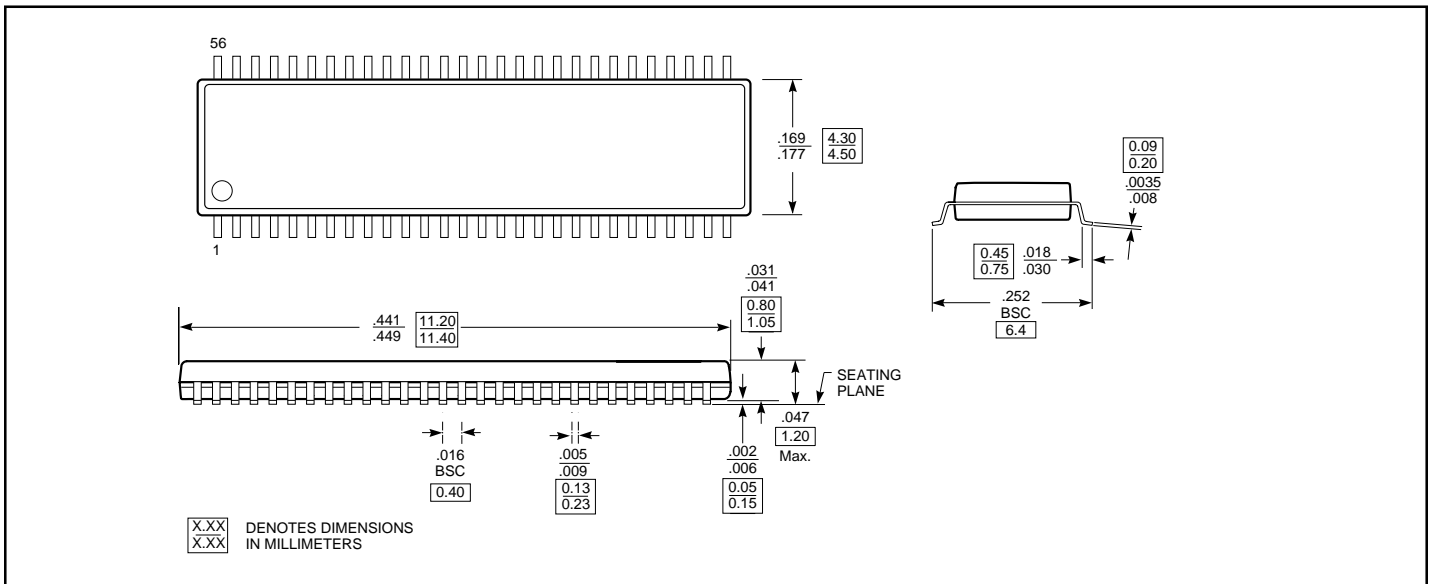

Ordering Information

Ordering Data	Description
PI74AVC+16821A	56-pin, 240-mil wide plastic TSSOP
PI74AVC+16821K	56-pin, 173-mil wide plastic TVSOP