

# SMT POWER INDUCTORS

## Shielded Drum Core - PG0048 Series

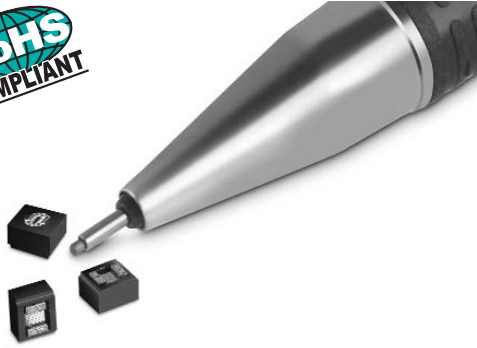

- Height:** 1.8mm Max
- Footprint:** 2.97mm x 2.54mm Max
- Current Rating:** up to .35A
- Inductance Range:** 6 $\mu$ H to 282 $\mu$ H

### Electrical Specifications @ 25°C — Operating Temperature -40°C to +125°C

Part <sup>7</sup> Number	Inductance @0Adc ( $\mu$ H $\pm$ 20%)	Inductance @Irated ( $\mu$ H TYP)	Irated <sup>5</sup> (mA)	DCR ( $\Omega$ )		Saturation <sup>6</sup> Current IsAT -40% (mA)	Heating <sup>7</sup> Current Idc +40°C (mA)	Q@1MHz (MIN)	SRF (MHz TYP)
				TYP	MAX				
PG0048.103	10	6.0	350	0.5	0.8	350	560	10	160
PG0048.153	15	9.0	226	1.1	1.3	226	440	10	110
PG0048.223	22	13.2	220	1.3	1.5	220	390	10	80
PG0048.333	33	19.8	176	1.7	1.9	176	330	15	50
PG0048.473	47	28.2	140	2.1	2.4	140	300	15	35
PG0048.683	68	40.8	110	2.4	2.6	110	260	15	25
PG0048.104	100	60	96	3.0	3.3	96	240	15	20
PG0048.154	150	90	80	6.2	6.5	80	180	15	15
PG0048.224	220	132	66	6.8	7.4	66	160	15	10
PG0048.334	330	198	55	10.5	11.2	55	140	15	5
PG0048.474	470	282	45	13.2	14.0	45	120	15	3

NOTES FROM TABLE: (See page 43)

### Mechanical

### Schematic

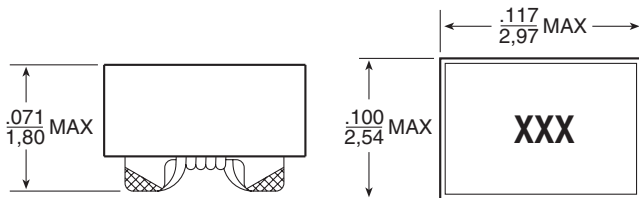

#### SUGGESTED PAD LAYOUT

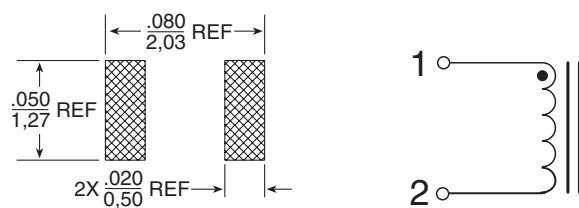

Weight .....0.1 grams  
Tape & Reel.....1600/reel

Dimensions: Inches  
mm  
Unless otherwise specified,  
all tolerances are  $\pm \frac{.010}{0.25}$

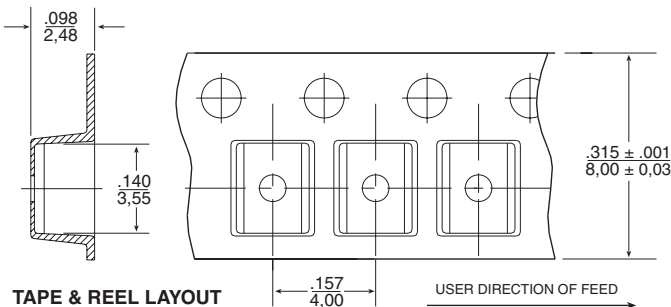

### Inductance vs Current Characteristics

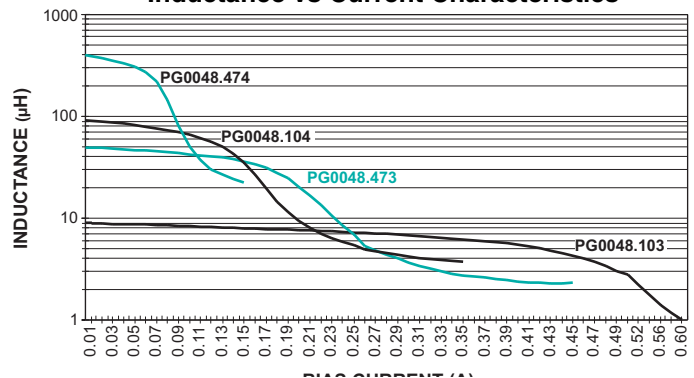

# SMT POWER INDUCTORS

## Shielded Drum Core Series



### Notes from Tables (pages 27 - 42)

1. Unless otherwise specified, all testing is made at 100kHz, 0.1VAC.
2. Optional Tape & Reel packaging can be ordered by adding a "T" suffix to the part number (i.e. P1166.102 becomes P1166.102T). Pulse complies with industry standard Tape and Tape & Reel specification EIA481.
3. To order RoHS compliant part, add the suffix "NL" to the part number (i.e. P1166.102 becomes P1166.102NL and P1166.102T becomes P1166.102NLT).
4. Temperature of the component (ambient plus temperature rise) must be within specified operating temperature range.
5. The rated current (I<sub>rated</sub>) as listed is either the saturation current or the heating current depending on which value is lower.
6. The saturation current, I<sub>sat</sub>, is the current at which the component inductance drops by the indicated percentage (typical) at an ambient temperature of 25°C. This current is determined by placing the component in the specified ambient environment and applying a short duration pulse current (to eliminate self-heating effects) to the component.
7. The heating current, I<sub>dc</sub>, is the DC current required to raise the component temperature by the indicated delta (approximately). The heating current is determined by mounting the component on a typical PCB and applying current for 30 minutes. The temperature is measured by placing the thermocouple on top of the unit under test.

8. In high volt\*time (Et) or ripple current applications, additional heating in the component can occur due to core losses in the inductor which may necessitate derating the current in order to limit the temperature rise of the component. In order to determine the approximate total loss (or temperature rise) for a given application, both copper losses and core losses should be taken into account.

### Estimated Temperature Rise:

$$\text{Trise} = [\text{Total loss (mW)} / K0]^{.833} (\text{°C})$$

$$\text{Total loss} = \text{Copper loss} + \text{Core loss (mW)}$$

$$\text{Copper loss} = I_{RMS}^2 \times \text{DCR (Typical)} \text{ (mW)}$$

$$I_{rms} = [I_{DC}^2 + \Delta I^2/12]^{1/2} \text{ (A)}$$

$$\text{Core loss} = K1 \times f \text{ (kHz)}^{1.23} \times B_{ac}(Ga)^{2.38} \text{ (mW)}$$

$$\text{Bac (peak to peak flux density)} = K2 \times \Delta I \text{ (Ga)}$$

$$[= K2/L(\mu H) \times Et(V-\mu Sec) \text{ (Ga)}]$$

where f varies between 25kHz and 1MHz, and Bac is less than 2500 Gauss.

K2 is a core size and winding dependant value and is given for each p/n in the proceeding datasheets. K0 & K1 are platform and material dependant constants and are given in the table below for each platform.

Part No.	Trise Factor (K0)	Core Loss Factor (K1)
PG0085/86	2.3	5.29E-10
PG0087	5.8	15.2E-10
PG0040/41	0.8	2.80E-10
P1174	0.8	6.47E-10
PF0601	4.6	14.0E-10
PF0464	3.6	24.7E-10
PF0465	3.6	33.4E-10
P1166	1.9	29.6E-10
P1167	2.1	42.2E-10
PF0560NL	5.5	136E-10
P1168/69	4.8	184E-10
P1170/71	4.3	201E-10
P1172/73	5.6	411E-10
PF0552NL	8.3	201E-10
PF0553NL	7.1	411E-10

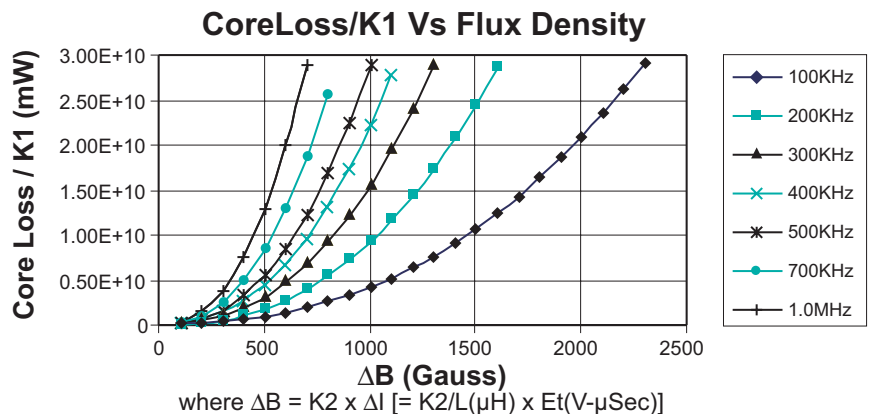

Take note that the component's temperature rise varies depending on the system condition. It is suggested that the component be tested at the system level, to verify the temperature rise of the component during system operation.