

Series 802 "Aqua Mouse"
Crimp Receptacles
802-002



Series 802
Submersible





How to Order Series 802 Crimp Receptacles

Series 802 Crimp Receptacles are available in two shell styles:

Jam Nut Mount for rear panel mounting.

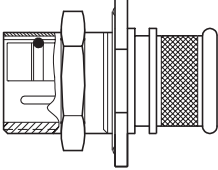
Box Mount for front mounting to a panel.

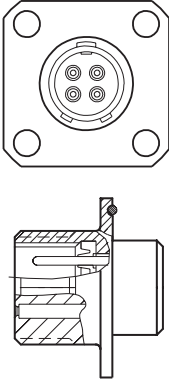
How To Order Series 802 Crimp Receptacles

| Series | Shell Style | Shell Material / Finish | Shell Size / Insert Arrangement | Contact Type | Shell Key Position |
|------------------------------|---|--|---|---|---|
| 802-002 Crimp Receptacles | 07 Jam Nut  | Z1 Stainless Steel, with Passivated Finish | 6-4 4 Contacts  | P Pin S Socket | N Normal Alternate Key Positions X Y Z |
| | 02 Square Flange  | | 6-7 7 Contacts  | | |

Part Number Example

802-002

—07

Z1

6 — 4

S

N

Series 802 Crimp Receptacle Dimensions

Series 802 Jam Nut Receptacle Dimensions

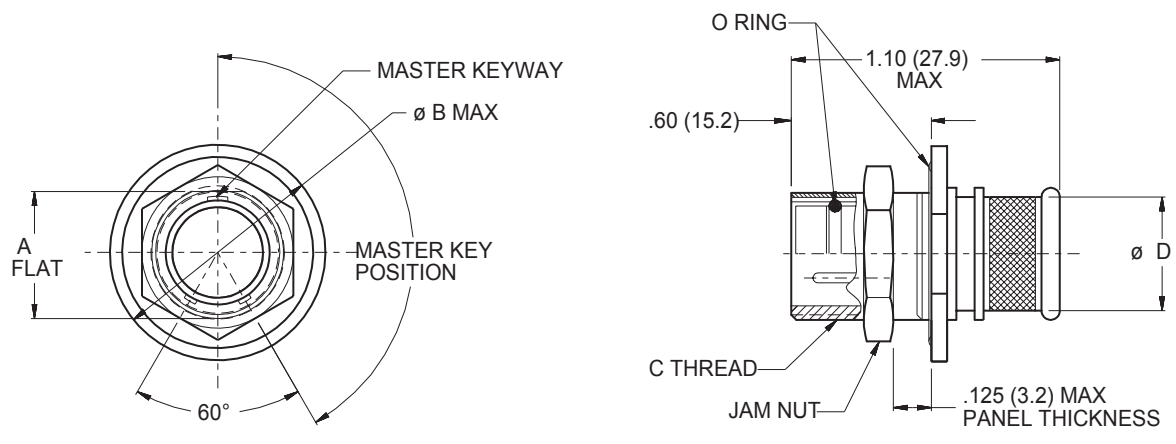

Series 802 Box Mount Receptacle Dimensions

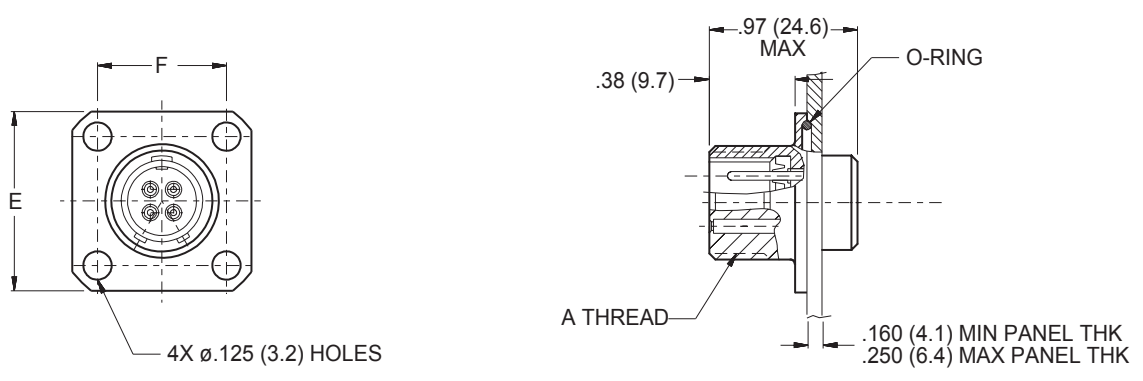

Series 802 Crimp Receptacle Dimensions

| Layout | A | Ø B Max | C Thread | Ø D | E | F |
|--------|-------------|--------------|-----------------|------------|--------------|-------------|
| 6-4 | .500 (12.7) | .906 (23.0) | .5625-20 UN-2A | .30 (7.6) | .875 (22.2) | .625 (15.9) |
| 6-7 | .500 (12.7) | .906 (23.0) | .5625-20 UN-2A | .30 (7.6) | .875 (22.2) | .625 (15.9) |
| 9-19 | .688 (17.5) | 1.062 (27.0) | .750-20 UNEF-2A | .52 (13.2) | 1.062 (27.0) | .812 (20.6) |