

μ PD70F3826, 70F3827, 70F3828, 70F3829, 70F3830, 70F3831, 70F3832, 70F3833, 70F3834, 70F3835, 70F3836, 70F3837

R01DS0029EJ0001

Rev.0.01

Sep 30, 2010

–V850ES/JE3-E, V850ES/JF3-E, V850ES/JG3-E– RENESAS MCU

Description

The μ PD70F3826, 70F3827, 70F3828, 70F3829 (V850ES/JF3-E), and μ PD70F3830, 70F3831, 70F3832, 70F3833 (V850ES/JF3-E), and μ PD70F3834, 70F3835, 70F3836, 70F3837 (V850ES/JG3-E) are products of the V850 32-bit single-chip microcontrollers, and include peripheral functions such as ROM/RAM, timer/counters, serial interfaces, an A/D converter, a DMA controller, a CAN controller, a USB function controller, and an Ethernet controller.

In addition to their high real-time responsiveness and one-clock-pitch execution of instructions, the V850ES/JE3-E, V850ES/JF3-E, and V850ES/JG3-E include instructions executed via a hardware multiplier, saturation instructions, and bit manipulation instructions.

Detailed function descriptions are provided in the following user's manuals. Be sure to read them before designing.

V850ES/JE3-E, V850ES/JF3-E, V850ES/JG3-E Hardware User's Manual: To be prepared

V850ES Architecture User's Manual:

U15943E

Features

- Number of instructions: 83
- Minimum instruction execution time:
20 ns (@ 50 MHz operation with main clock (fx))
- Clock
 - Main clock oscillation: $f_x = 3$ to 6.25 MHz
 - Subclock oscillation: $f_{XT} = 32.768$ kHz
 - Internal oscillation: $f_R = 220$ kHz (TYP.)
- General-purpose registers: 32 bits \times 32 registers
- Instruction set:
Signed multiplication, saturation operations, 32-bit shift instructions, bit manipulation instructions, load/store instructions
- Memory space:
64 MB linear address space
- Internal memory
Flash memory: 64/128/256 KB
RAM: 32/48/64 KB
(Including 16 KB of data RAM area)
- I/O lines Total: 26/42/62
- Interrupts and exceptions
Non-maskable interrupts: 2 sources
Maskable interrupts: 63/78/85 sources
- Timer/counters
 - 16-bit timer/event counter AA (TAA): 5 channels
 - 16-bit timer/event counter AB (TAB): 1 channel
 - Motor control function supported
 - 16-bit interval timer M (TMM): 4 channels
 - 16-bit encoder timer T (TMT): 1 channel
- Real-time counter: 1 channel
- Watchdog timer: 1 channel
- Real-time output function: 6 channels
- A/D converter: 10-bit resolution \times 10/10 channels
- Ethernet controller: 1 channel
- USB function controller: 1 channel
- Serial interface
 - CAN :1 channel (μ PD70F3829, 70F3833, 70F3837 only)
 - Asynchronous serial interface C(UARTC): 3/4 channels
 - Clocked serial interface F(CSIF): 2/3/5 channels
 - I²C bus interface: 2/3 channels
- DMA controller: 4 channels
- Power save function:
HALT/IDLE1/IDLE2/STOP/subclock/sub-IDLE mode
- On-chip debug function
- Package: 64-pin LQFP (V850ES/JE3-E)
64-pin WQFN (V850ES/JE3-E)
80-pin LQFP (V850ES/JF3-E)
100-pin LQFP (V850ES/JG3-E)
113-pin FBGA (Under planing)
- Operating supply voltage: 2.85 to 3.6 V

Function list (V850ES/JE3-E)

Generic Name		V850ES/JE3-E			
Product Name		μPD70F3826	μPD70F3827	μPD70F3828	μPD70F3829
Internal memory	Flash memory	64 KB	128 KB	256 KB	256 KB
	Internal RAM	16 KB	32 KB	48 KB	48 KB
	Data RAM	16 KB	16 KB	16 KB	16 KB
Memory space		64 MB			
General-purpose register		32 bits × 32 registers			
Clocks	Main clock oscillation	PLL mode : f _x = 3 to 6.25 MHz, f _{xx} = 24 to 50 MHz (multiplication by 8) Clock through mode : f _x = 3 to 6.25 MHz (internal : f _{xx} = 3 to 6.25 MHz)			
	Subclock oscillation	f _{xT} = 32.768 kHz			
	Internal oscillation	f _R = 220 kHz (TYP.)			
	Minimum instruction execution time	20 ns (@ 50 MHz operation with main system clock (f _{xx}))			
I/O ports		I/O: 26 (5 V tolerant : 12)			
Timer	16-bit TAA	5 channels (among which two channels have the interval function only)			
	16-bit TAB	-			
	16-bit TMM	4 channels			
	16-bit TMT	1 channel (Interval function only)			
	Motor control	-			
	Watch timer	1 channel (RTC)			
	WDT	1 channel			
Real-time output function		6 bits × 1 channel			
10-bit A/D converter		10 channels			
Serial interface	CSIF/UARTC	1 channel			
	CSIF/UARTC/I ² C	1 channel			
	CSIF	-			
	UARTC/I ² C	1 channel			-
	UARTC/I ² C/CAN	-	-	-	1 channel
USB function		1 channel			
Ethernet controller		1 channel			
DMA controller		4 channels (transfer target: on-chip peripheral I/O, internal RAM)			
Interrupt source	External ^{Note 1, 2}	7(7)	7(7)	7(7)	7(7)
	Internal	54	54	54	58
Power-save function		HALT/IDLE1/IDLE2/STOP/subclock/sub-IDLE modes			
Reset factor		RESET pin input, watchdog timer 2 (WDT2), clock monitor (CLM), low-voltage detector (LVI)			
On-chip debugging		MINICUBE®, MINICUBE2 supported			
Operating supply voltage		2.85 to 3.6 V			
Operating ambient temperature		-40 to +85°C			
Package		64-pin plastic LQFP (fine pitch) (10 × 10 mm), 64-pin plastic WQFN (9 × 9 mm),			

- Notes**
1. The figure in parentheses indicates the number of external interrupts that can release the STOP mode.
 2. Include NMI.

Function list (V850ES/JF3-E)

Generic Name		V850ES/JF3-E			
Product Name		μPD70F3830	μPD70F3831	μPD70F3832	μPD70F3833
Internal memory	Flash memory	64 KB	128 KB	256 KB	256 KB
	Internal RAM	16 KB	32 KB	48 KB	48 KB
	Data RAM	16 KB	16 KB	16 KB	16 KB
Memory space		64 MB			
General-purpose register		32 bits × 32 registers			
Clocks	Main clock oscillation	PLL mode : f _x = 3 to 6.25 MHz, f _{xx} = 24 to 50 MHz (multiplication by 8) Clock through mode : f _x = 3 to 6.25 MHz (internal : f _{xx} = 3 to 6.25 MHz)			
	Subclock oscillation	f _{xT} = 32.768 kHz			
	Internal oscillation	f _R = 220 kHz (TYP.)			
	Minimum instruction execution time	20 ns (@ 50 MHz operation with main system clock (f _{xx}))			
I/O ports		I/O: 42 (5 V tolerant : 28)			
Timer	16-bit TAA	5 channels			
	16-bit TAB	1 channel			
	16-bit TMM	4 channels			
	16-bit TMT	1 channel			
	Motor control	1 channel			
	Watch timer	1 channel (RTC)			
	WDT	1 channel			
Real-time output function		6 bits × 1 channel			
10-bit A/D converter		10 channels			
Serial interface	CSIF/UARTC	1 channel			
	CSIF/UARTC/I ² C	2 channels			
	CSIF	-			
	UARTC/I ² C	1 channel			-
	UARTC/I ² C/CAN	-			1 channel
USB function		1 channel			
Ethernet controller		1 channel			
DMA controller		4 channels (transfer target: on-chip peripheral I/O, internal RAM)			
Interrupt source	External ^{Note 1, 2}	19(19)	19(19)	19(19)	19(19)
	Internal	57	57	57	61
Power-save function		HALT/IDLE1/IDLE2/STOP/subclock/sub-IDLE modes			
Reset factor		RESET pin input, watchdog timer 2 (WDT2), clock monitor (CLM), low-voltage detector (LVI)			
On-chip debugging		MINICUBE, MINICUBE2 supported			
Operating supply voltage		2.85 to 3.6 V			
Operating ambient temperature		-40 to +85°C			
Package		80-pin plastic LQFP (fine pitch) (12 × 12 mm)			

- Notes**
1. The figure in parentheses indicates the number of external interrupts that can release the STOP mode.
 2. Include NMI.

Function list (V850ES/JG3-E)

Generic Name		V850ES/JG3-E			
Product Name		μPD70F3834	μPD70F3835	μPD70F3836	μPD70F3837
Internal memory	Flash memory	64 KB	128 KB	256 KB	256 KB
	Internal RAM	16 KB	32 KB	48 KB	48 KB
	Data RAM	16 KB	16 KB	16 KB	16 KB
Memory space		64 MB			
General-purpose register		32 bits × 32 registers			
Clocks	Main clock oscillation	PLL mode : f _x = 3 to 6.25 MHz, f _{xx} = 24 to 50 MHz (multiplication by 8) Clock through mode : f _x = 3 to 6.25 MHz (internal : f _{xx} = 3 to 6.25 MHz)			
	Subclock oscillation	f _{xT} = 32.768 kHz			
	Internal oscillation	f _R = 220 kHz (TYP.)			
	Minimum instruction execution time	20 ns (@ 50 MHz operation with main system clock (f _{xx}))			
I/O ports		I/O: 62 (5 V tolerant : 35)			
Timer	16-bit TAA	5 channels			
	16-bit TAB	1 channel			
	16-bit TMM	4 channels			
	16-bit TMT	1 channel			
	Motor control	1 channel			
	Watch timer	1 channel (RTC)			
	WDT	1 channel			
Real-time output function		6 bits × 1 channel			
10-bit A/D converter		10 channels			
Serial interface	CSIF/UARTC	1 channel			
	CSIF/UARTC/I ² C	2 channels			
	CSIF	2 channels			
	UARTC/I ² C	1 channel			–
	UARTC/I ² C/CAN	–			1 channel
USB function		1 channel			
Ethernet controller		1 channel			
DMA controller		4 channels (transfer target: on-chip peripheral I/O, internal RAM)			
Interrupt source	External ^{Note 1, 2}	22(22)	22(22)	22(22)	22(22)
	Internal	61	61	61	65
Power-save function		HALT/IDLE1/IDLE2/STOP/subclock/sub-IDLE modes			
Reset factor		RESET pin input, watchdog timer 2 (WDT2), clock monitor (CLM), low-voltage detector (LVI)			
On-chip debugging		MINICUBE, MINICUBE2 supported			
Operating supply voltage		2.85 to 3.6 V			
Operating ambient temperature		–40 to +85°C			
Package		100-pin plastic LQFP (fine pitch) (14 × 14 mm), 113-pin plastic FBGA ^{Note3}			

- Notes**
1. The figure in parentheses indicates the number of external interrupts that can release the STOP mode.
 2. Include NMI.
 3. Under planning.

APPLICATIONS

- Applications that require Ethernet controller
Home audio, printers, and scanners.

ORDERING INFORMATION

- V850ES/JE3-E

Part Number	Package	On-Chip Flash Memory
μPD70F3826GB-GAH-AX	64-pin plastic LQFP (fine pitch) (10 × 10)	64 KB
μPD70F3827GB-GAH-AX	64-pin plastic LQFP (fine pitch) (10 × 10)	128 KB
μPD70F3828GB-GAH-AX	64-pin plastic LQFP (fine pitch) (10 × 10)	256 KB
μPD70F3829GB-GAH-AX	64-pin plastic LQFP (fine pitch) (10 × 10)	256 KB
μPD70F3826K8-6B4-AX	64-pin plastic WQFN (9 × 9)	64 KB
μPD70F3827K8-6B4-AX	64-pin plastic WQFN (9 × 9)	128 KB
μPD70F3828K8-6B4-AX	64-pin plastic WQFN (9 × 9)	256 KB
μPD70F3829K8-6B4-AX	64-pin plastic WQFN (9 × 9)	256 KB

- V850ES/JF3-E

Part Number	Package	On-Chip Flash Memory
μPD70F3830GK-GAK-AX	80-pin plastic LQFP (fine pitch) (12 × 12)	64 KB
μPD70F3831GK-GAK-AX	80-pin plastic LQFP (fine pitch) (12 × 12)	128 KB
μPD70F3832GK-GAK-AX	80-pin plastic LQFP (fine pitch) (12 × 12)	256 KB
μPD70F3833GK-GAK-AX	80-pin plastic LQFP (fine pitch) (12 × 12)	256 KB

- V850ES/JG3-E

Part Number	Package	On-Chip Flash Memory
μPD70F3834GC-UEU-AX	100-pin plastic LQFP (fine pitch) (14 × 14)	64 KB
μPD70F3835GC-UEU-AX	100-pin plastic LQFP (fine pitch) (14 × 14)	128 KB
μPD70F3836GC-UEU-AX	100-pin plastic LQFP (fine pitch) (14 × 14)	256 KB
μPD70F3837GC-UEU-AX	100-pin plastic LQFP (fine pitch) (14 × 14)	256 KB
μPD70F3837F1-CAH-AX ^{Note}	113-pin plastic FBGA (8 × 8)	256 KB

Note Under planning

Remark The V850ES/Jx3-E microcontrollers are lead-free products.

PIN CONFIGURATION

- V850ES/JE3-E
64-pin plastic LQFP (fine pitch) (10 × 10)
μPD70F3826GB-GAH-AX μPD70F3827GB-GAH-AX
μPD70F3828GB-GAH-AX μPD70F3829GB-GAH-AX

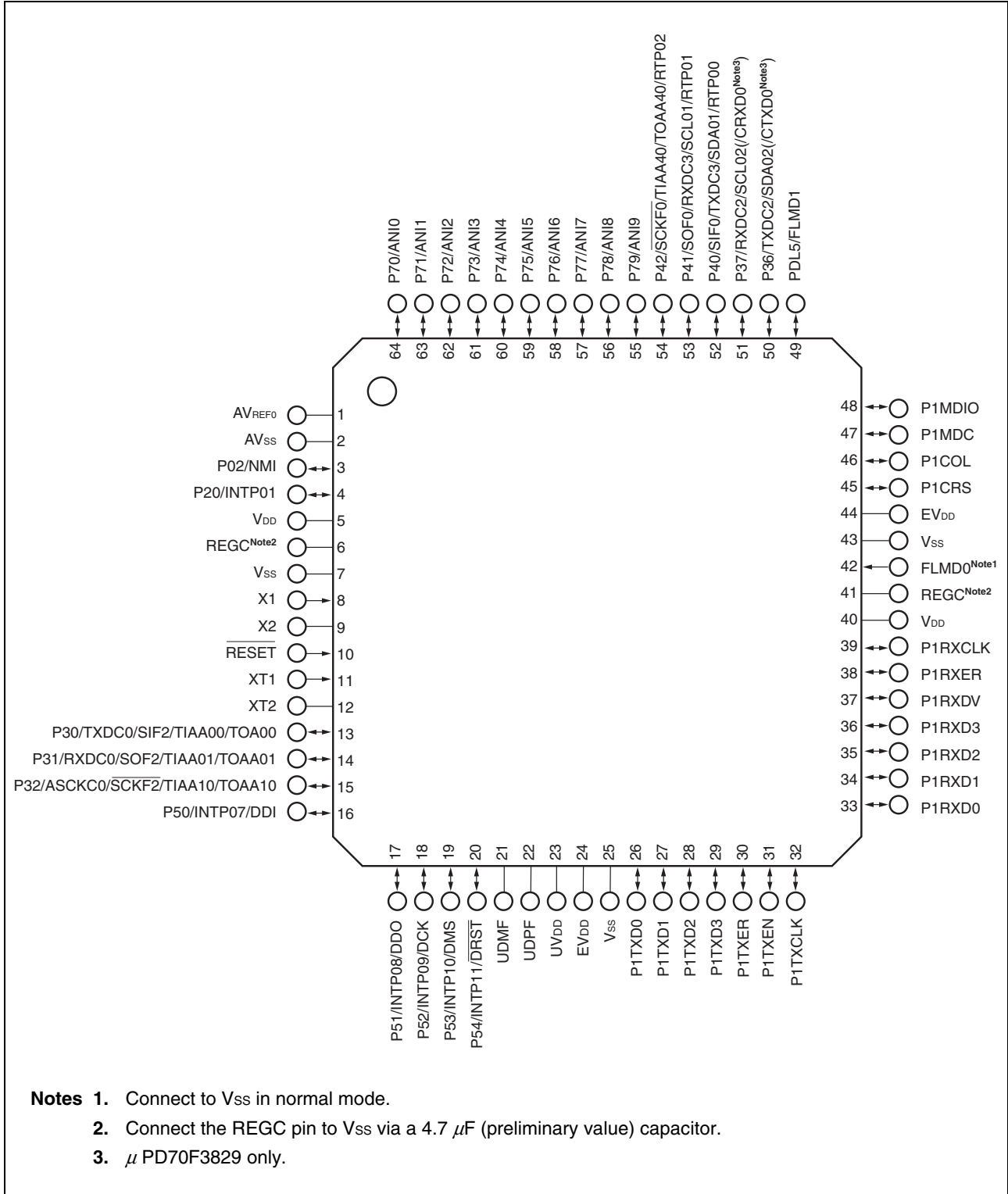

• V850ES/JE3-E

64-pin plastic WQFN (9 × 9)

μPD70F3826K8-6B4-AX

μPD70F3827K8-6B4-AX

μPD70F3828 K8-6B4-AX

μPD70F3829K8-6B4-AX

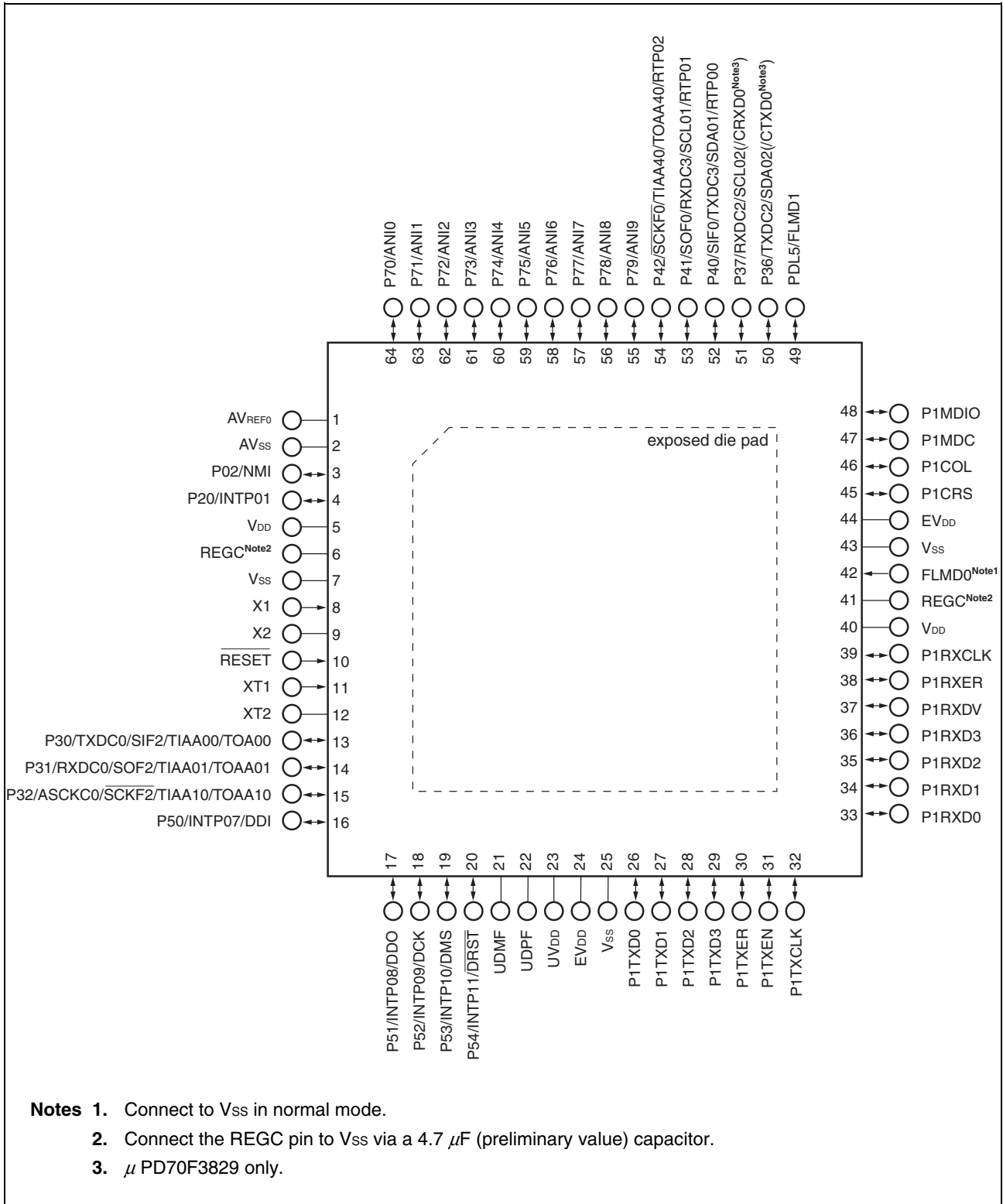

• V850ES/JF3-E

80-pin plastic LQFP (fine pitch) (12 × 12)

μPD70F3830GK-GAK-AX

μPD70F3831GK-GAK-AX

μPD70F3832GK-GAK-AX

μPD70F3833GK-GAK-AX

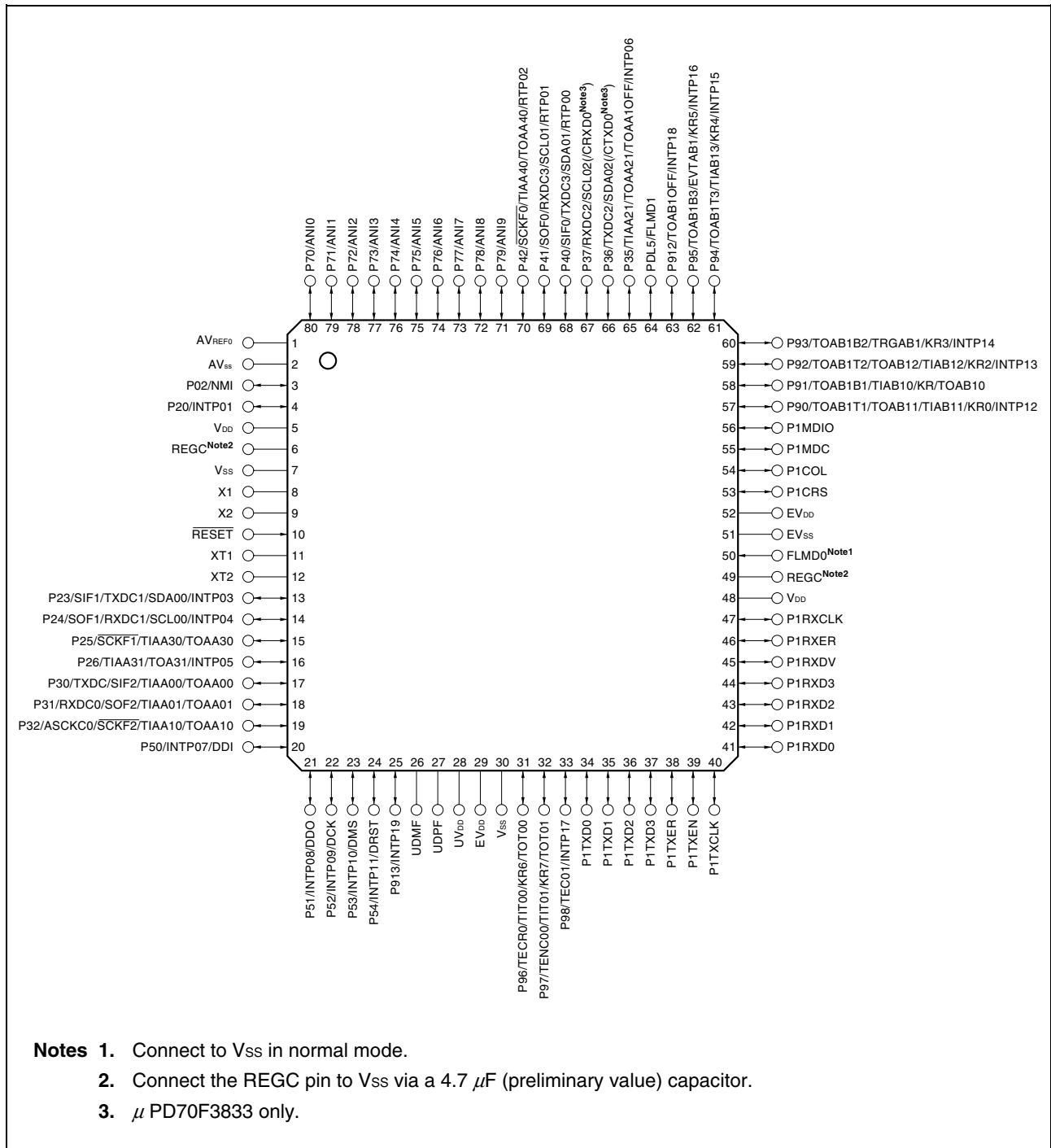

- Notes**
1. Connect to V_{SS} in normal mode.
 2. Connect the REGC pin to V_{SS} via a 4.7 μF (preliminary value) capacitor.
 3. μPD70F3833 only.

- V850ES/JG3-E
 100-pin plastic LQFP (fine pitch) (14 × 14)
 μPD70F3834GC-UEU-AX μPD70F3835GC-UEU-AX
 μPD70F3836GC-UEU-AX μPD70F3837GC-UEU-AX

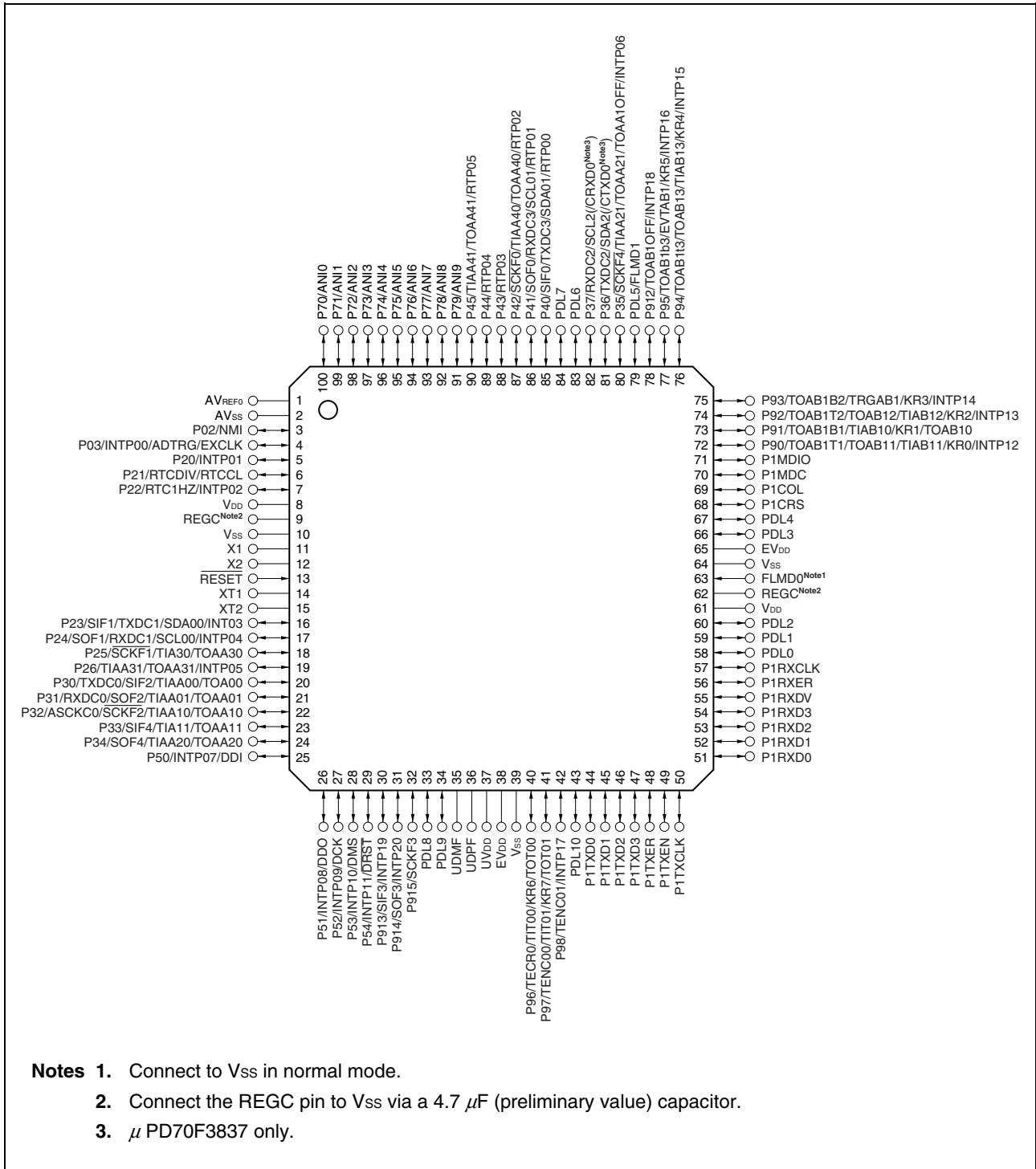

- Notes**
1. Connect to Vss in normal mode.
 2. Connect the REGC pin to Vss via a 4.7 μF (preliminary value) capacitor.
 3. μPD70F3837 only.

PIN IDENTIFICATION

ADTRG:	A/D Trigger Input	RXDC0 to RXDC3	Receive Data
ANI0 to ANI9:	Analog Input	$\overline{\text{SCKF0}}$ to $\overline{\text{SCKF4}}$:	Serial Clock
ASCKC0:	Asynchronous Serial Clock	SCL00 to SCL02:	Serial Clock
AVREF0:	Analog Reference Voltage	SDA00 to SDA02:	Serial Data
AVSS:	Grand for Analog Pin	SIF0 to SIF4:	Serial Input
CRXD0:	CAN Receive Data	SOF0 to SOF4:	Serial Output
CTXD0:	CAN Transmit Data	TECR0:	Timer Encoder Clear Input
DCK:	Debug Clock	TENC00, TENC01:	Timer Encoder Input
DDI:	Debug Data Input	TIAA00, TIAA01,	Timer Input
DDO:	Debug Data Output	TIAA10, TIAA11,	
DMS:	Debug Mode Select	TIAA20, TIAA21,	
$\overline{\text{DRST}}$:	Debug Reset	TIAA30, TIAA31,	
EVDD:	Power Supply for External Pin	TIAA40, TIAA41,	
EVTAB1:	Timer Event Count Input	TIAB10 to TIAB13,	
EXCLK	USB clock	TIT00, TIT01:	
FLMD0, FLMD1:	Flash Programming Mode	TOAA00, TOAA01,	Timer Output
INTP00 to INTP20:	External Interrupt Input	TOAA10, TOAA11,	
KR0 to KR7:	Key Return	TOAA20, TOAA21,	
NMI:	Non-maskable Interrupt Request	TOAA30, TOAA31,	
P02, P03:	Port0	TOAA40, TOAA41,	
P1COL, P1CRS,	Ethernet PHY Interface	TOAB10 to TOAB13,	
P1MDC, P1MDIO,		TOAB1B1 to TOAB1B3,	
P1RXCLK,		TOAB1T1 to TOAB1T3,	
P1RXD0 to P1RXD3,		TOT00, TOT01:	
P1RXDV, P1RXER		TOAA1OFF,	Timer Output Off
P1TXCLK,		TOAB1OFF	
P1TXD0 to P1TXD3,		TRGAB1:	Timer Trigger Input
P1TXEN, P1TXER:		TXDC0 to TXDC3:	Serial Output
P20 to P26	Port2	UDMF:	USB Data I/O (-) Function
P30 to P37:	Port3	UDPF:	USB Data I/O (+) Function
P40 to P45:	Port4	UVDD:	Power Supply for External USB
P50 to P54:	Port5	VDD:	Power Supply
P70 to P79:	Port7	VSS:	Ground
P90 to P98,	Port9	X1, X2:	Crystal for Main Clock
P912 to P915:		XT1, XT2:	Crystal for Sub-clock
PDL0 to PDL10:	Port DL		
REGC:	Regulator Control		
$\overline{\text{RESET}}$:	Reset		
RTC1HZ, RTCCL,	Real-time Counter Clock Output		
RTCDIV:			
RTP00 to RTP05:	Real-time Output Port		

INTERNAL BLOCK DIAGRAM

• V850ES/JE3-E

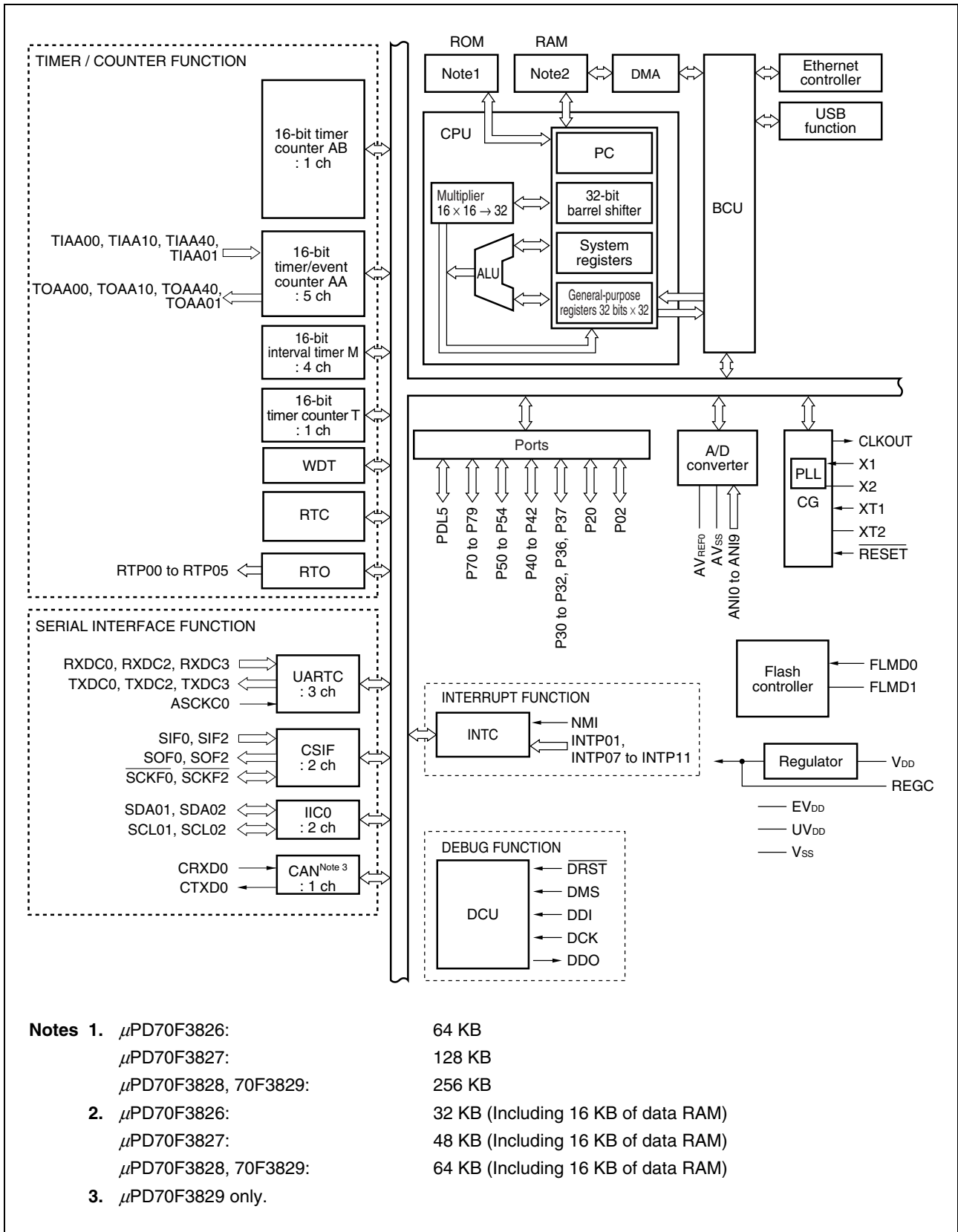

• V850ES/JF3-E

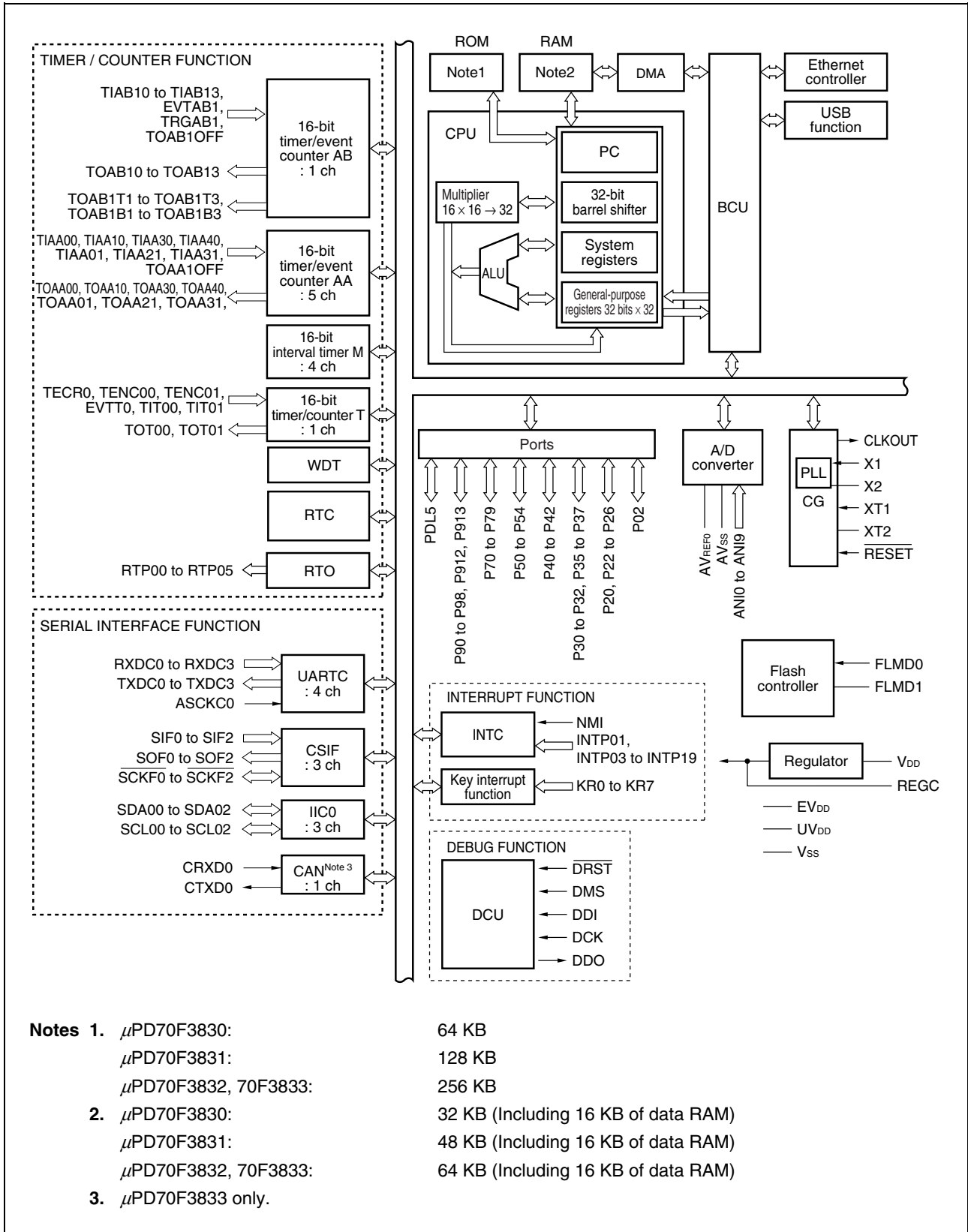

• V850ES/JG3-E

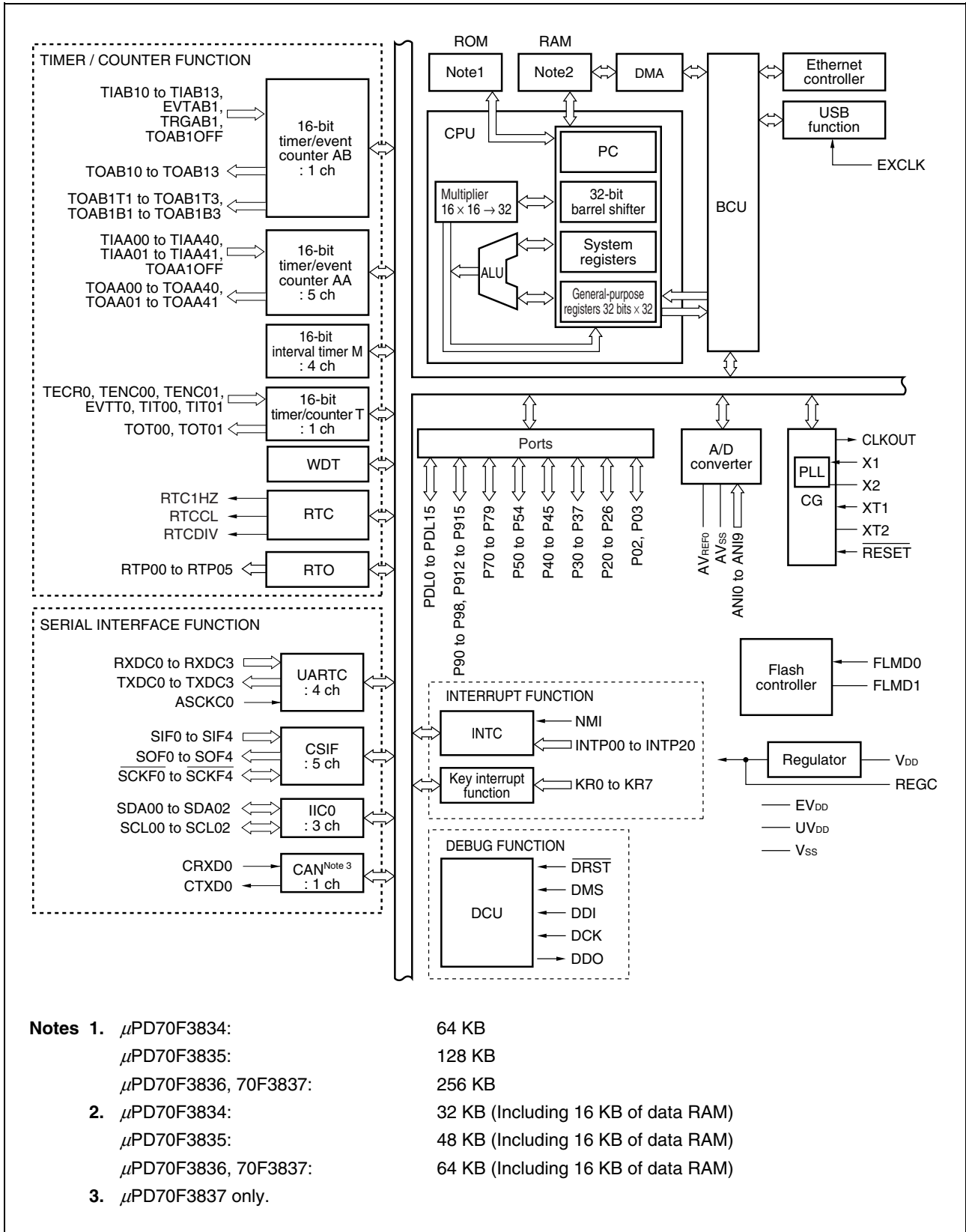

CONTENTS

1.	PIN FUNCTIONS	15
1.1	Port Pins.....	15
1.2	Non-Port Pins.....	17
1.3	Pin I/O Circuits and Recommended Connection of Unused Pins.....	22
2.	CPU FUNCTIONS	26
3.	MEMORY MAP	27
4.	PORTS.....	29
5.	CLOCK GENERATION FUNCTION.....	30
6.	16-BIT TIMER/EVENT COUNTER AA (TAA).....	32
7.	16-BIT TIMER/EVENT COUNTER AB (TAB).....	34
8.	16-BIT TIMER/EVENT COUNTER T (TMT).....	36
9.	16-BIT INTERVAL TIMER M (TMM).....	38
10.	MOTOR CONTROL FUNCTION	39
11.	REAL-TIME COUNTER.....	41
12.	WATCHDOG TIMER 2 FUNCTIONS.....	43
13.	REAL-TIME OUTPUT FUNCTION (RTO).....	44
14.	A/D CONVERTER	45
15.	ASYNCHRONOUS SERIAL INTERFACE C (UARTC).....	47
16.	CLOCKED SERIAL INTERFACE F (CSIF)	49
17.	I ² C BUS	51
18.	CAN CONTROLLER.....	53
19.	USB FUNCTION CONTROLLER (USBF).....	54
20.	ETHERNET CONTROLLER.....	55
21.	DMA CONTROLLER	56
22.	INTERRUPT/EXCEPTION PROCESSING FUNCTION.....	58
23.	KEY INTERRUPT FUNCTION (V850ES/JF3-E, V850ES/JG3-E).....	62
24.	STANDBY FUNCTION	63
25.	RESET FUNCTIONS.....	64
26.	CLOCK MONITOR, LOW-VOLTAGE DETECTOR.....	65
27.	CRC FUNCTIONS	66
28.	REGULATOR FUNCTION.....	67
29.	FLASH MEMORY	68
30.	ON-CHIP DEBUG FUNCTION	69
31.	PACKAGE DRAWINGS.....	70

1. PIN FUNCTIONS

1.1 Port Pins

(1/2)

Pin Name	I/O	Function	Alternate Function	Pin number		
				JE3-E	JF3-E	JG3-E
P02	I/O	Port 0 2-bit I/O port(V850ES/JG3-E) 1-bit I/O port(V850ES/JE3-E, V850ES/JF3-E) Input/output can be specified in 1-bit units.	NMI	3	3	3
P03			INTP00/ADTRG/EXCLK	-	-	4
P20	I/O	Port 2 7-bit I/O port(V850ES/JG3-E) 5-bit I/O port(V850ES/JF3-E) 1-bit I/O port(V850ES/JE3-E) Input/output can be specified in 1-bit units.	INTP01	4	4	5
P21			RTGDIV/RTCCCL	-	-	6
P22			RTC1HZ/INTP02	-	-	7
P23			SIF1/TXDC1/SDA00/INTP03	-	13	16
P24			SOF1/RXDC1/SDL00/INTP04	-	14	17
P25			SCKF1/TIAA30/TOAA30	-	15	18
P26			TIAA31/TOAA31/INTP05	-	16	19
P30	I/O	Port 3 8-bit I/O port(V850ES/JG3-E) 6-bit I/O port(V850ES/JF3-E) 5-bit I/O port(V850ES/JE3-E) Input/output can be specified in 1-bit units.	TXDC0/SIF2/TIAA00/TOAA00	13	17	20
P31			RXDC0/SOF2/TIAA01/TOAA01	14	18	21
P32			ASCKC0/SCKF2/TIAA10/TOAA10	15	19	22
P33			SIF4/TIAA11/TOAA11	-	-	23
P34			SOF4/TIAA20/TOAA20	-	-	24
P35			SCKF4/TIAA21/TOAA21 /TOAA1OFF/INTP06	-	-	80
			TIAA21/TOAA21/TOAA1OFF/INTP06	-	65	-
P36			TXDC2/SDA02/CTXD0 ^{Note}	50	66	81
P37	RXDC2/SCL02/CRXD0 ^{Note}	51	67	82		
P40	I/O	Port 4 6-bit I/O port(V850ES/JG3-E) 3-bit I/O port(V850ES/JE3-E, V850ES/JF3-E) Input/output can be specified in 1-bit units.	SIF0/TXDC3/SDA01/RTP00	52	68	85
P41			SOF0/RXDC3/SCL01/RTP01	53	69	86
P42			SCKF0/TIAA40/TOAA40/RTP02	54	70	87
P43			RTP03	-	-	88
P44			RTP04	-	-	89
P45			TIAA41/TOAA41/RTP05	-	-	90
P50	I/O	Port 5 5-bit I/O port Input/output can be specified in 1-bit units.	INTP07/DDI	16	20	25
P51			INTP08/DDO	17	21	26
P52			INTP09/DCK	18	22	27
P53			INTP10/DMS	19	23	28
P54			INTP11/DRST	20	24	29

Note Available only in on-chip CAN controller products

Remark JE3-E: V850ES/JE3-E, JF3-E: V850ES/JF3-E, JG3-E: V850ES/JG3-E

(2/2)

Pin Name	I/O	Function	Alternate Function	Pin number		
				JE3-E	JF3-E	JG3-E
P70	I/O	Port 7 10-bit I/O port Input/output can be specified in 1-bit units.	ANI0	64	80	100
P71			ANI1	63	79	99
P72			ANI2	62	78	98
P73			ANI3	61	77	97
P74			ANI4	60	76	96
P75			ANI5	59	75	95
P76			ANI6	58	74	94
P77			ANI7	57	73	93
P78			ANI8	56	72	92
P79			ANI9	55	71	91
P90	I/O	Port 9 13-bit I/O port(V850ES/JG3-E) 11-bit I/O port(V850ES/JF3-E) Input/output can be specified in 1-bit units.	TOAB1T1/TOAB11/TIAB11/KR0/INTP12	-	57	72
P91			TOAB1B1/TIAB10/KR1/TOAB10	-	58	73
P92			TOAB1T2/TOAB12/TIAB12/KR2/INTP13	-	59	74
P93			TOAB1B2/TRGAB1/KR3/INTP14	-	60	75
P94			TOAB1T3/TOAB13/TIAB13/KR4/INTP15	-	61	76
P95			TOAB1B3/EVTB1/KR5/INTP16	-	62	77
P96			TECR0/TIT00/KR6/TOT00	-	31	40
P97			TENC00/TIT01/KR7/TOT01	-	32	41
P98			TENC01/INTP17	-	33	42
P912			TOAB1OFF/INTP18	-	63	78
P913			SIF31/INTP19	-	-	30
			INTP19	-	25	-
P914			SOF3/INTP20	-	-	31
P915			SCKF3	-	-	32
PDL0			I/O	Port DL 11-bit I/O port(V850ES/JG3-E) 1-bit I/O port(V850ES/JF3-E, V850ES/JE3-E) Input/output can be specified in 1-bit units.	-	-
PDL1	-	-			-	59
PDL2	-	-			-	60
PDL3	-	-			-	66
PDL4	-	-			-	67
PDL5	FLMD1	49			64	79
PDL6	-	-			-	83
PDL7	-	-			-	84
PDL8	-	-			-	33
PDL9	-	-			-	34
PDL10	-	-	-	43		

Remark JE3-E: V850ES/JE3-E, JF3-E: V850ES/JF3-E, JG3-E: V850ES/JG3-E

1.2 Non-Port Pins

(1/5)

Pin Name	I/O	Function	Alternate Function	Pin number		
				JE3-E	JF3-E	JG3-E
ADTRG	Input	External trigger input for A/D converter	P03/INTP00/EXCLK	–	–	4
ANI0	Input	Analog voltage input for A/D converter	P70	64	80	100
ANI1			P71	63	79	99
ANI2			P72	62	78	98
ANI3			P73	61	77	97
ANI4			P74	60	76	96
ANI5			P75	59	75	95
ANI6			P76	58	74	94
ANI7			P77	57	73	93
ANI8			P78	56	72	92
ANI9			P79	55	71	91
ASCKC0	Input	UARTC0 baud rate clock input	P32/SCKF2/TIAA10/TOAA10	15	19	22
AV _{REF0}	–	Reference voltage input for A/D converter, and positive power supply for port 7	–	1	1	1
AV _{SS}	–	Ground voltage for A/D converter	–	2	2	2
CRXD0 ^{Note}	Input	CAN receive data input	P37/RXDC2/SCL02	51	67	82
CTXD0 ^{Note}	Output	CAN transmit data output	P36/TXDC2/SDA02	50	66	81
DCK	Input	Clock input for on-chip debugging	P52/INTP09	18	22	27
DDI	Input	Data input for on-chip debugging	P50/INTP07	16	20	25
DDO	Output	Data output for on-chip debugging In the on-chip debug mode, high-level output is forcibly set.	P51/INTP08	17	21	26
DMS	Input	Mode select signal input for on-chip debugging	P53/INTP10	19	23	28
DRST	Input	Reset signal input for on-chip debugging	P54/INTP11	20	24	29
EV _{DD}	–	Positive power supply for external (same potential as V _{DD})	–	24, 44	29, 52	38, 65
EVTAB1	Input	External event count input of TAB1	P95/TOAB1B3/KR5/INTP16	–	62	77
EXCLK	Input	USB clock signal input	P03/INTP00/ADTRG	–	–	4
FLMD0	Input	Flash programming mode setting pins	–	42	50	63
FLMD1	Input		PDL5/AD5	49	64	79
INTP00	Input	External interrupt request input (maskable, analog noise elimination). Analog noise elimination or digital noise elimination selectable for INTP02 pin.	P03/ADTRG/EXCLK	–	–	4
INTP01			P20	4	4	5
INTP02			P22/RTC1HZ	–	–	7
INTP03			P23/SIF1/TXDC1/SDA00	–	13	16
INTP04			P24/SOF1/RXDC1/SDL00	–	14	17
INTP05			P26/TIAA31/TOAA31	–	16	19
INTP06			P35/SCKF4/TIAA21/TOAA21 /TOAA1OFF	–	–	80
			P35/TIAA21/TOAA21/TOAA1OFF	–	65	–
INTP07			P50/DDI	16	20	25
INTP08			P51/DDO	17	21	26
INTP09			P52/DCK	18	22	27
INTP10	P53/DMS	19	23	28		

Note Available only in on-chip CAN controller products

Remark JE3-E: V850ES/JE3-E, JF3-E: V850ES/JF3-E, JG3-E: V850ES/JG3-E

(2/5)

Pin Name	I/O	Function	Alternate Function	Pin number		
				JE3-E	JF3-E	JG3-E
INTP11	Input	External interrupt request input (maskable, analog noise elimination).	P54/DRST	20	24	29
INTP12			P90/TOAB1T1/TOAB11/TIAB11 /KR0	-	57	72
INTP13			P92/TOAB1T2/TOAB12/TIAB12 /KR2	-	59	74
INTP14			P93/TOAB1B2/TRGAB1/KR3	-	60	75
INTP15			P94/TOAB1T3/TOAB13/TIAB13 /KR4	-	61	76
INTP16			P95/TOAB1B3/EVTAB1/KR5	-	62	77
INTP17			P98/TENC01	-	33	42
INTP18			P912/TOAB1OFF	-	63	78
INTP19			P913/SIF3	-	-	30
INTP20			P913	-	25	-
					P914/SOF3	-
KR0	Input	Key interrupt input (analog noise elimination)	P90/TOAB1T1/TOAB11/TIAB11 /INTP12	-	57	72
KR1			P91/TOAB1B1/TIAB10/TOAB10	-	58	73
KR2			P92/TOAB1T2/TOAB12/TIAB12 /INTP13	-	59	74
KR3			P93/TOAB1B2/TRGAB1/INTP14	-	60	75
KR4			P94/TOAB1T3/TOAB13/TIAB13 /INTP15	-	61	76
KR5			P95/TOAB1B3/EVTAB1/INTP16	-	62	77
KR6			P96/TECR0/TIT00/TOT00	-	31	40
KR7			P97/TENC00/TIT01/TOT01	-	32	41
NMI	Input	External interrupt (non-maskable, analog noise elimination)	P02	3	3	3
P1COL	Input	Collision detection input for Ethernet	-	46	54	69
P1CRS	Input	Carrier detection input for Ethernet	-	45	53	68
P1MDC	Output	Serial transmit clock output	-	32	40	50
P1MDIO	I/O	Serial I/O	-	47	55	70
P1RXCLK	Input	Receive clock input for Ethernet	-	48	56	71
P1RXD0	Input	Receive data input for Ethernet	-	39	47	57
P1RXD1	Input	Receive data input for Ethernet	-	33	41	51
P1RXD2	Input	Receive data input for Ethernet	-	34	42	52
P1RXD3	Input	Receive data input for Ethernet	-	35	43	53
P1RXDV	Input	Receive data VALID input for Ethernet	-	36	44	54
P1RXER	Input	Receive data error input for Ethernet	-	37	45	55
P1TXCLK	Output	Transmit clock output for Ethernet	-	38	46	56
P1TXD0	Output	Transmit data output for Ethernet	-	26	34	44
P1TXD1	Output	Transmit data output for Ethernet	-	27	35	45
P1TXD2	Output	Transmit data output for Ethernet	-	28	36	46
P1TXD3	Output	Transmit data output for Ethernet	-	29	37	47
P1TXEN	Output	Transmit data enable output for Ethernet	-	31	39	49
P1TXER	Output	Transmit error output for Ethernet	-	30	38	48

Remark JE3-E: V850ES/JE3-E, JF3-E: V850ES/JF3-E, JG3-E: V850ES/JG3-E

(3/5)

Pin Name	I/O	Function	Alternate Function	Pin number		
				JE3-E	JF3-E	JG3-E
REGC	–	Connecting capacitor for regulator output stabilization (4.7 μF (preliminary value))	–	6, 41	6, 49	9, 62
RESET	Input	System reset input	–	10	10	13
RTC1HZ	Output	Real-time counter correction clock (1 Hz) output	P22/INTP02	–	–	7
RTCC	Output	Real-time counter clock (original 32 kHz clock) output	P21/RTCDIV	–	–	6
RTCDIV	Output	Real-time counter clock (divided 32 kHz clock) output	P21/RTCC	–	–	6
RTP00	Output	Real-time output port RTP00, RTP01 are N-ch open-drain output selectable.	P40/SIF0/TXDC3/SDA01	52	68	85
RTP01			P41/SOF0/RXDC3/SCL01	53	69	86
RTP02			P42/SCKF0/TIAA40/TOAA40	54	70	87
RTP03			P43	–	–	88
RTP04			P44	–	–	89
RTP05			P45/TIAA41/TOAA41	–	–	90
RXDC0	Input	Serial receive data input (UARTC0 to UARTC3)	P31/SOF2/TIAA01/TOAA01	14	18	21
RXDC1			P24/SOF1/SDL00/INTP04	–	14	17
RXDC2			P37/SCL02/CRXD0 ^{Note}	51	67	82
RXDC3			P41/SOF0/SCL01/RTP01	53	69	86
SCKF0	I/O	Serial clock I/O (CSIF0 to CSIF4)	P42/TIAA40/TOAA40/RTP02	54	70	87
SCKF1			P25/TIAA30/TOAA30	–	15	18
SCKF2			P32/ASCKC0/TIAA10/TOAA10	15	19	22
SCKF3			P915	–	–	32
SCKF4			P35/TIAA21/TOAA21/TOAA1OFF /INTP06	–	–	80
SCL00	I/O	Serial clock I/O (I ² C00 to I ² C02) N-ch open-drain output selectable.	P24/SOF1/RXDC1/INTP04	–	14	17
SCL01			P41/SOF0/RXDC3/RTP01	53	69	86
SCL02			P37/RXDC2/CRXD0 ^{Note}	51	67	82
SDA00	I/O	Serial transmit/receive data I/O (I ² C00 to I ² C02) N-ch open-drain output selectable.	P23/SIF1/TXDC1/INTP03	–	13	16
SDA01			P40/SIF0/TXDC3/RTP00	52	68	85
SDA02			P36/TXDC2/CTXD0 ^{Note}	50	66	81
SIF0	Input	Serial receive data input (CSIF0 to CSIF4)	P40/TXDC3/SDA01/RTP00	52	68	85
SIF1			P23/TXDC1/SDA00/INTP03	–	13	16
SIF2			P30/TXDC0/TIAA00/TOAA00	13	17	20
SIF3			P913/INTP19	–	–	30
SIF4			P33/TIAA11/TOAA11	–	–	23
SOF0	Output	Serial transmit data output (CSIF0 to CSIF4) N-ch open-drain output selectable.	P41/RXDC3/SCL01/RTP01	53	69	86
SOF1			P24/RXDC1/SDL00/INTP04	–	14	17
SOF2			P31/RXDC0/TIAA01/TOAA01	14	18	21
SOF3			P914/INTP20	–	–	31
SOF4			P34/TIAA20/TOAA20	–	–	24
TECR0	Input	Encoder clear input of TMT0	P96/TIT00/KR6/TOT00	–	31	40
TENC00		Encoder input/external event input/external trigger input of TMT0	P97/TIT01/KR7/TOT01	–	32	41
TENC01		Encoder input of TMT0	P98/INTP17	–	33	42

Note Available only in on-chip CAN controller products

Remark JE3-E: V850ES/JE3-E, JF3-E: V850ES/JF3-E, JG3-E: V850ES/JG3-E

(4/5)

Pin Name	I/O	Function	Alternate Function	Pin number			
				JE3-E	JF3-E	JG3-E	
TIAA00	Input	Capture trigger input/external event input/external trigger input (TAA0)	P30/TXDC0/SIF2/TOAA00	13	17	20	
TIAA01		Capture trigger input (TAA0)	P31/RXDC0/SOF2/TOAA01	14	18	21	
TIAA10		Capture trigger input/external event input/external trigger input (TAA1)	P32/ASCKC0/SCKF2/TOAA10	15	19	22	
TIAA11		Capture trigger input (TAA1)	P33/SIF4/TXDB0/TOAA11	-	-	23	
TIAA20		Capture trigger input/external event input/external trigger input (TAA2)	P34/SOF4/RXDB0/TOAA20	-	-	24	
TIAA21		Capture trigger input (TAA2)	P35/SCKF4/TOAA21/TOAA1OFF /INTP06	-	-	80	
			TIAA21/TOAA21/TOAA1OFF/INT P06	-	65	-	
TIAA30		Capture trigger input/external event input/external trigger input (TAA3)	P25/SCKF1/TOAA30	-	15	18	
TIAA31		Capture trigger input (TAA3)	P26/TOAA31/INTP05	-	16	19	
TIAA40		Capture trigger input/external event input/external trigger input (TAA4)	P42/SCKF0/TOAA40/RTP02	54	70	87	
TIAA41		Capture trigger input (TAA4)	P45/SCKE0/TOAA41/RTP05	-	-	90	
TIAB10		Input	Capture trigger input/external event input/external trigger input (TAB1) N-ch open-drain output selectable.	P91/TOAB1B1/KR1/TOAB10	-	58	73
TIAB11			Capture trigger input (TAB1)	P90/TOAB1T1/TOAB11/KR0/INTP12	-	57	72
TIAB12	N-ch open-drain output selectable.		P92/TOAB1T2/TOAB12/KR2/INTP13	-	59	74	
TIAB13			P94/TOAB1T3/TOAB13/KR4/INTP15	-	61	76	
TIT00	Input	Capture trigger input of TMT0	P96/TECR0/KR6/TOT00	-	31	40	
TIT01		N-ch open-drain output selectable.	P97/TENC00/KR7/TOT01	-	32	41	
TOAA00	Output	Timer output (TAA0)	P30/TXDC0/SIF2/TIAA00	13	17	20	
TOAA01		N-ch open-drain output selectable.	P31/RXDC0/SOF2/TIAA01	14	18	21	
TOAA10		Timer output (TAA1)	P32/ASCKC0/SCKF2/TIAA10	15	19	22	
TOAA11		N-ch open-drain output selectable.	P33/SIF4/TIAA11	-	-	23	
TOAA1OFF	Input	TAA1 High-impedance output control signal input	P35/SCKF4/TIAA21/TOAA21/INTP06	-	-	80	
			P35/TIAA21/TOAA21/INTP06	-	65	-	
TOAA20	Output	Timer output (TAA2)	P34/SOF4/TIAA20	-	-	24	
TOAA21		N-ch open-drain output selectable.	P35/SCKF4/TIAA21/TOAA1OFF /INTP06	-	-	80	
			P35/TIAA21/TOAA1OFF/INTP06	-	65	-	
TOAA30		Timer output (TAA3)	P25/SCKF1/TIAA30/	-	15	18	
TOAA31		N-ch open-drain output selectable.	P26/TIAA31/INTP05	-	16	19	
TOAA40		Timer output (TAA4)	P42/SCKF0/TIAA40/RTP02	54	70	87	
TOAA41		N-ch open-drain output selectable.	P45/SCKE0/TIAA41/RTP05	-	-	90	
TOAB10	Output	Timer output (TAB1)	P91/TOAB1B1/TIAB10/KR1	-	58	73	
TOAB11		N-ch open-drain output selectable.	P90/TOAB1T1/TIAB11/KR0/INTP12	-	57	72	
TOAB12			P92/TOAB1T2/TIAB12/KR2/INTP13	-	59	74	
TOAB13			P94/TOAB1T3/TIAB13/KR4/INTP15	-	61	76	

Remark JE3-E: V850ES/JE3-E, JF3-E: V850ES/JF3-E, JG3-E: V850ES/JG3-E

(5/5)

Pin Name	I/O	Function	Alternate Function	Pin number		
				JE3-E	JF3-E	JG3-E
TOAB1B1	Output	Pulse signal output for 6-phase PWM low arm of TAB1	P91/TIAB10/KR1/TOAB10	–	58	73
TOAB1B2			P93/TRGAB1/KR3/INTP14	–	60	75
TOAB1B3			P95/EVTAB1/KR5/INTP16	–	62	77
TOAB1OFF	Input	TAB1 High-impedance output control signal input	P912/INTP18	–	63	78
TOAB1T1	Output	Pulse signal output for 6-phase PWM high arm of TAB1. N-ch open-drain output selectable.	P90/TOAB11/TIAB11/KR0/INTP12	–	57	72
TOAB1T2			P92/TOAB12/TIAB12/KR2/INTP13	–	59	74
TOAB1T3			P94/TOAB13/TIAB13/KR4/INTP15	–	61	76
TOT00	Output	Timer output of TMT0	P96/TECR0/TIT00/KR6	–	31	40
TOT01		N-ch open-drain output selectable	P97/TENC00/TIT01/KR7	–	32	41
TRGAB1	Input	External trigger input of TAB1 N-ch open-drain output selectable	P93/TOAB1B2/KR3/INTP14	–	60	75
TXDC0	Output	Serial transmit data output (UARTC0 to UARTC3) N-ch open-drain output selectable.	P30/SIF2/TIAA00/TOAA00	13	17	20
TXDC1			P23/SIF1/SDA00/INTP03	–	13	16
TXDC2			P36/SDA02/CTXD0 ^{Note}	50	66	81
TXDC3			P40/SIF0/SDA01/RTP00	52	68	85
UDMF	I/O	USB data I/O (–) function	–	21	26	35
UDPF		USB data I/O (+) function	–	22	27	36
UV _{DD}	–	3.3 V positive power supply for USB	–	23	28	37
V _{DD}	–	Positive power supply for internal circuit	–	5	5	8
V _{SS}	–	Ground potential for internal circuit	–	7	7	10
X1	Input	Connecting resonator for main clock	–	8	8	11
X2	–		–	9	9	12
XT1	Input	Connecting resonator for subclock	–	8	11	14
XT2	–		–	9	12	15

Note Available only in on-chip CAN controller products.

Remark JE3-E: V850ES/JE3-E, JF3-E: V850ES/JF3-E, JG3-E: V850ES/JG3-E

1.3 Pin I/O Circuits and Recommended Connection of Unused Pins

The I/O circuit type of each pin and recommended connection of unused pins are shown in Table 1-1. For the schematic circuit diagram of each type, refer to **Figure 1-1**.

Table 1-1. Types of Pin I/O Circuits (1/3)

Pin Name	Alternate Function	I/O Circuit Type	Recommended Connection of Unused Pins	JE3-E	JF3-E	JG3-E
P02	NMI	10-D	Input: Independently connect to EV _{DD} or V _{SS} via a resistor. Output: Leave open.	3	3	3
P03	INTP00/ADTRG/EXCLK			-	-	4
P20	TOAB02/INTP01	10-D	Input: Independently connect to EV _{DD} or V _{SS} via a resistor. Output: Leave open.	4	4	5
P21	RTCDIV/RTCCL			-	-	6
P22	RTC1HZ/INTP02			-	-	7
P23	SIF1/TXDC1/SDA00/INTP03			-	13	16
P24	SOF1/RXDC1/SCL00/INTP04			-	14	17
P25	SCKF1/TIAA30/TOAA30			-	15	18
P26	TIAA31/TOAA31/INTP05			-	16	19
P27	TIAB03/TOAB03/INTP21			4	4	5
P30	TXDC0/SIF2/TIAA00/TOAA00	10-D	Input: Independently connect to EV _{DD} or V _{SS} via a resistor. Output: Leave open.	13	17	20
P31	RXDC0/SOF2/TIAA01/TOAA01			14	18	21
P32	ASCKC0/SCKF2/TIAA10/TOAA10			15	19	22
P33	SIF4/TIAA11/TOAA11			-	-	23
P34	SOF4/TIAA20/TOAA20			-	-	24
P35	SCKF4/TIAA21/TOAA21 /TOAA1OFF/INTP06			-	-	80
	----- TIAA21/TOAA21/TOAA1OFF/INTP06			-	65	-
P36	TXDC2/SDA02/CTXD0 ^{Note}			50	66	81
P37	RXDC2/SCL02/CRXD0 ^{Note}	51	67	82		
P40	SIF0/TXDC3/SDA01/RTP00	10-D	Input: Independently connect to EV _{DD} or V _{SS} via a resistor. Output: Leave open.	52	68	85
P41	SOF0/RXDC3/SCL01/RTP01			53	69	86
P42	SCKF0/TIAA40/TOAA40/RTP02			54	70	87
P43	RTP03			-	-	88
P44	RTP04			-	-	89
P45	TIAA41/TOAA41/RTP05			-	-	90
P50	INTP07/DDI	10-D	Input: Independently connect to EV _{DD} or V _{SS} via a resistor. Output: Leave open.	16	20	25
P51	INTP08/DDO			17	21	26
P52	INTP09/DCK			18	22	27
P53	INTP10/DMS			19	23	28
P54	INTP11/DRST	10-N	Input: Independently connect to V _{SS} via a resistor. Fixing to V _{DD} level is prohibited. Output: Leave open. Internally pull-down after reset by RESET pin.	20	24	29
P70 to P79	ANI0 to ANI9	11-G	Input: Independently connect to AV _{REF0} or AV _{SS} via a resistor. Output: Leave open.	64 to 55	80 to 71	100 to 91

Note Available only in on-chip CAN controller products.

Remark JE3-E: V850ES/JE3-E, JF3-E: V850ES/JF3-E, JG3-E: V850ES/JG3-E

Table 1-1. Types of Pin I/O Circuits (2/3)

Pin Name	Alternate Function	I/O Circuit Type	Recommended Connection of Unused Pins	JE3-E	JF3-E	JG3-E	
P90	TOAB1T1/TOAB11/TIAB11/KR0 /INTP12	10-D	Input: Independently connect to EV _{DD} or V _{SS} via a resistor. Output: Leave open.	-	57	72	
P91	TOAB1B1/TIAB10/KR1/TOAB10			-	58	73	
P92	TOAB1T2/TOAB12/TIAB12/KR2 /INTP13			-	59	74	
P93	TOAB1B2/TRGAB1/KR3/INTP14			-	60	75	
P94	TOAB1T3/TOAB13/TIAB13/KR4 /INTP15			-	61	76	
P95	TOAB1B3/EVTB1/KR5/INTP16			-	62	77	
P96	TECR0/TIT00/KR6/TOT00			-	31	40	
P97	TENC00/TIT01/KR7/TOT01			-	32	41	
P98	TENC01/INTP17			-	33	42	
P912	TOAB1OFF/INTP18			-	63	78	
P913	SIF3/INTP19			-	-	30	
	INTP19			-	25	-	
P914	SOF3/INTP20			-	-	31	
P915	SCKF3			-	-	32	
PDL0 to PDL4	-			5	Input: Independently connect to EV _{DD} or V _{SS} via a resistor.	-	-
PDL5	FLMD1	5	Output: Leave open.	49	64	79	
PDL6 to PDL10	-	5		-	-	83,84, 33,34, 43	
AV _{REF0}	-	-	Directly connect to V _{DD} and always supply power.	1	1	1	
AV _{SS}	-	-	Directly connect to V _{SS} .	2	2	2	
EV _{DD}	-	-	Directly connect to V _{DD} and always supply power.	24, 44	29, 52	38, 65	
FLMD0	-	-	Connect to V _{SS} in other than flash mode.	42	50	63	
P1COL	-	5	Independently connect to EV _{DD} or V _{SS} via a resistor.	46	54	69	
P1CRS	-	5		45	53	68	
P1MDIO	-	5		47	55	70	
P1RXCLK	-	5		48	56	71	
P1RXD0	-	5		39	47	57	
P1RXD1	-	5		33	41	51	
P1RXD2	-	5		34	42	52	
P1RXD3	-	5		35	43	53	
P1RXDV	-	5		36	44	54	
P1RXER	-	5		37	45	55	
P1TXCLK	-	5		38	46	56	
P1MDC	-	5		Leave open.	32	40	50
P1TXD0	-	5			26	34	44
P1TXD1	-	5			27	35	45
P1TXD2	-	5			28	36	46
P1TXD3	-	5	29		37	47	
P1TXEN	-	5	31		39	49	
P1TXER	-	5	30		38	48	

Remark JE3-E: V850ES/JE3-E, JF3-E: V850ES/JF3-E, JG3-E: V850ES/JG3-E

Table 1-1. Types of Pin I/O Circuits (3/3)

Pin Name	Alternate Function	I/O Circuit Type	Recommended Connection of Unused Pins	JE3-E	JF3-E	JG3-E
REGC	–	–	Connect to regulator output stabilization (4.7 μF (preliminary value)) capacitor.	6, 41	6, 49	9, 62
RESET	–	2	–	10	10	13
UDMF	–	–	Leave open.	21	26	35
UDPF	–	–	Leave open.	22	27	36
UV _{DD}	–	–	Directly connect to V _{DD} and always supply power.	23	28	37
V _{DD}	–	–	–	5	5	8
V _{SS}	–	–	–	7	7	10
X1	–	–	–	8	8	11
X2	–	–	–	9	9	12
XT1	–	16-C	Connect to V _{SS} via a resistor.	8	11	14
XT2	–	16-C	Leave open.	9	12	15

Remark JE3-E: V850ES/JE3-E, JF3-E: V850ES/JF3-E, JG3-E: V850ES/JG3-E

Figure 1-1. Pin I/O Circuits

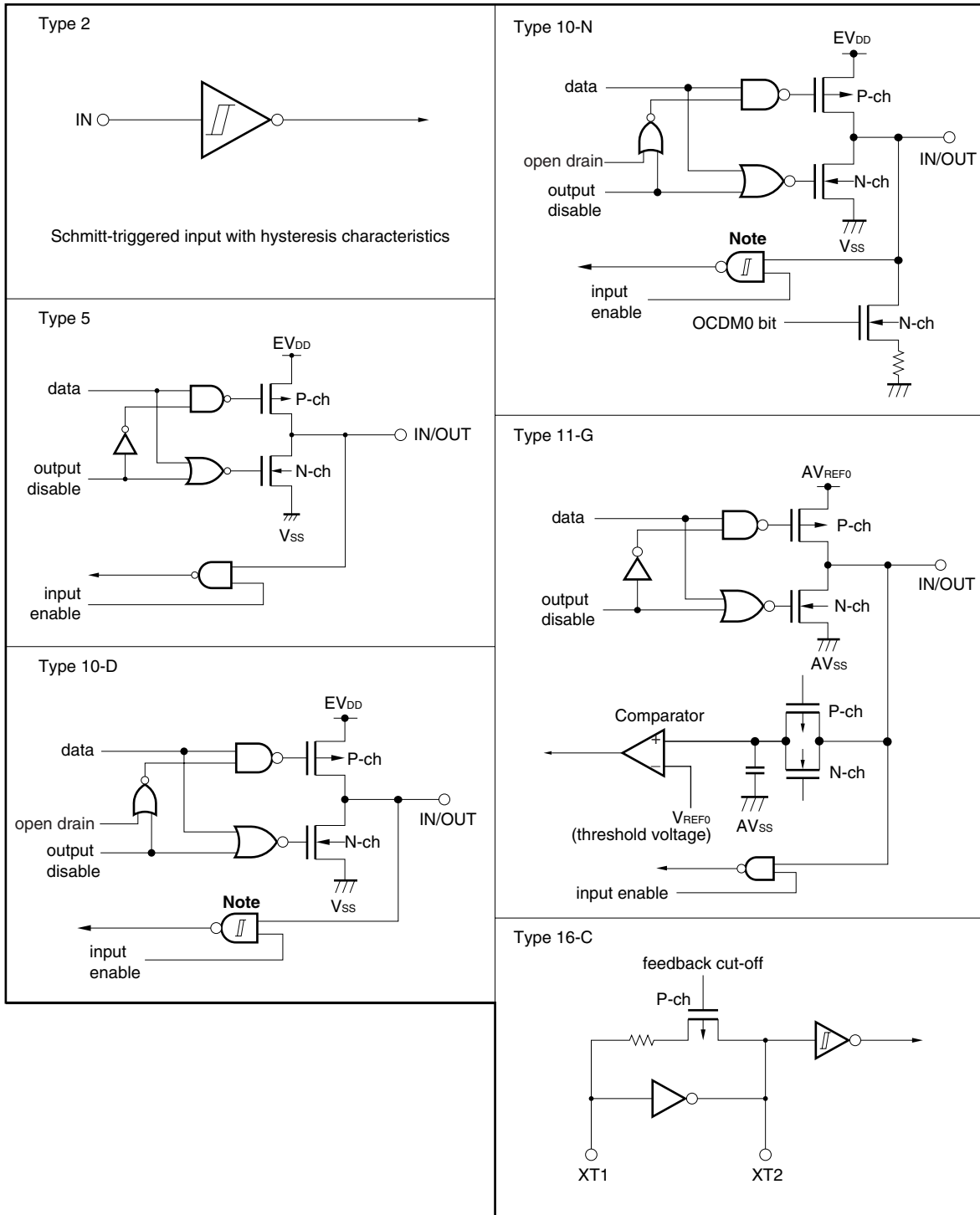

Note Hysteresis characteristics are not available in port mode.

2. CPU FUNCTIONS

The CPU of the V850ES/JE3-E, V850ES/JF3-E and V850ES/JG3-E is based on RISC architecture and executes most instructions in a 1-clock cycle by using a 5-stage pipeline.

The features of the CPU are as follows.

- Minimum instruction execution time: 20 ns (@ 50 MHz operation with main clock (f_{xx}))
30.5 μs (@ 32.768 kHz operation with sub-clock (f_{XT}))
- Memory space Program space: 64 MB linear
 Data space: 4 GB linear
- General-purpose registers: 32 bits × 32 registers
- Internal 32-bit architecture
- 5-stage pipeline control
- Multiplication/division instructions
- Saturation operation instructions
- 1-clock 32-bit shift instruction
- Load/store instructions with long/short format
- Internal memory

Table 2-1. ROM/RAM

Generic Name	Products	Flash Memory Size	RAM Size	
			Internal RAM	Data RAM
V850ES/JE3-E	μPD70F3826	64 KB	16 KB	16 KB
	μPD70F3827	128 KB	32 KB	16 KB
	μPD70F3828	256 KB	48 KB	16 KB
	μPD70F3829	256 KB	48 KB	16 KB
V850ES/JF3-E	μPD70F3830	64 KB	16 KB	16 KB
	μPD70F3831	128 KB	32 KB	16 KB
	μPD70F3832	256 KB	48 KB	16 KB
	μPD70F3833	256 KB	48 KB	16 KB
V850ES/JG3-E	μPD70F3834	64 KB	16 KB	16 KB
	μPD70F3835	128 KB	32 KB	16 KB
	μPD70F3836	256 KB	48 KB	16 KB
	μPD70F3837	256 KB	48 KB	16 KB

- Four types of bit manipulation instructions
 - SET1
 - CLR1
 - NOT1
 - TST1

3. MEMORY MAP

The memory maps of the V850ES/JE3-E, V850ES/JF3-E and V850ES/JF3-E are shown below.

○ Address Space

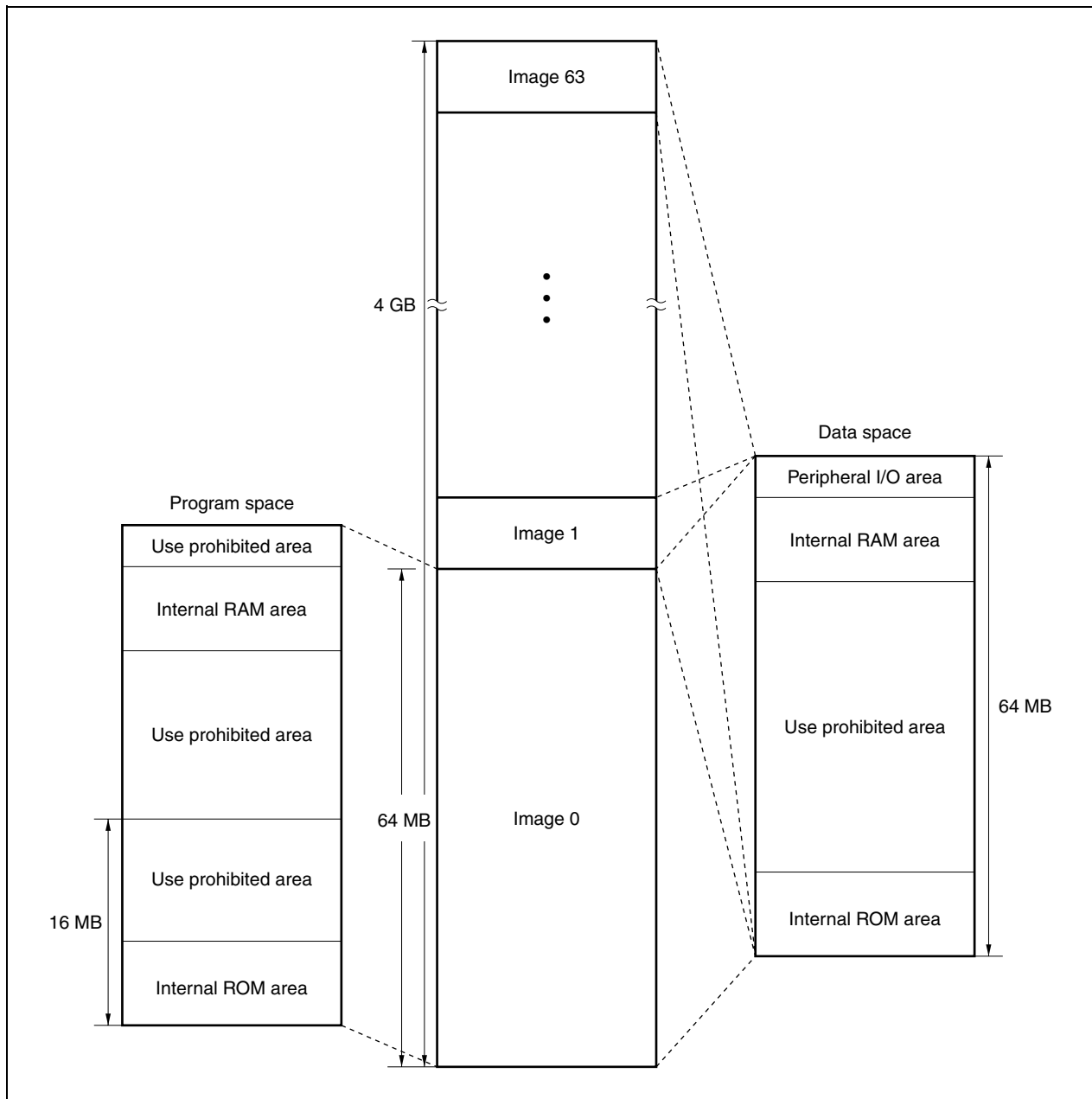

○ Data Memory Map

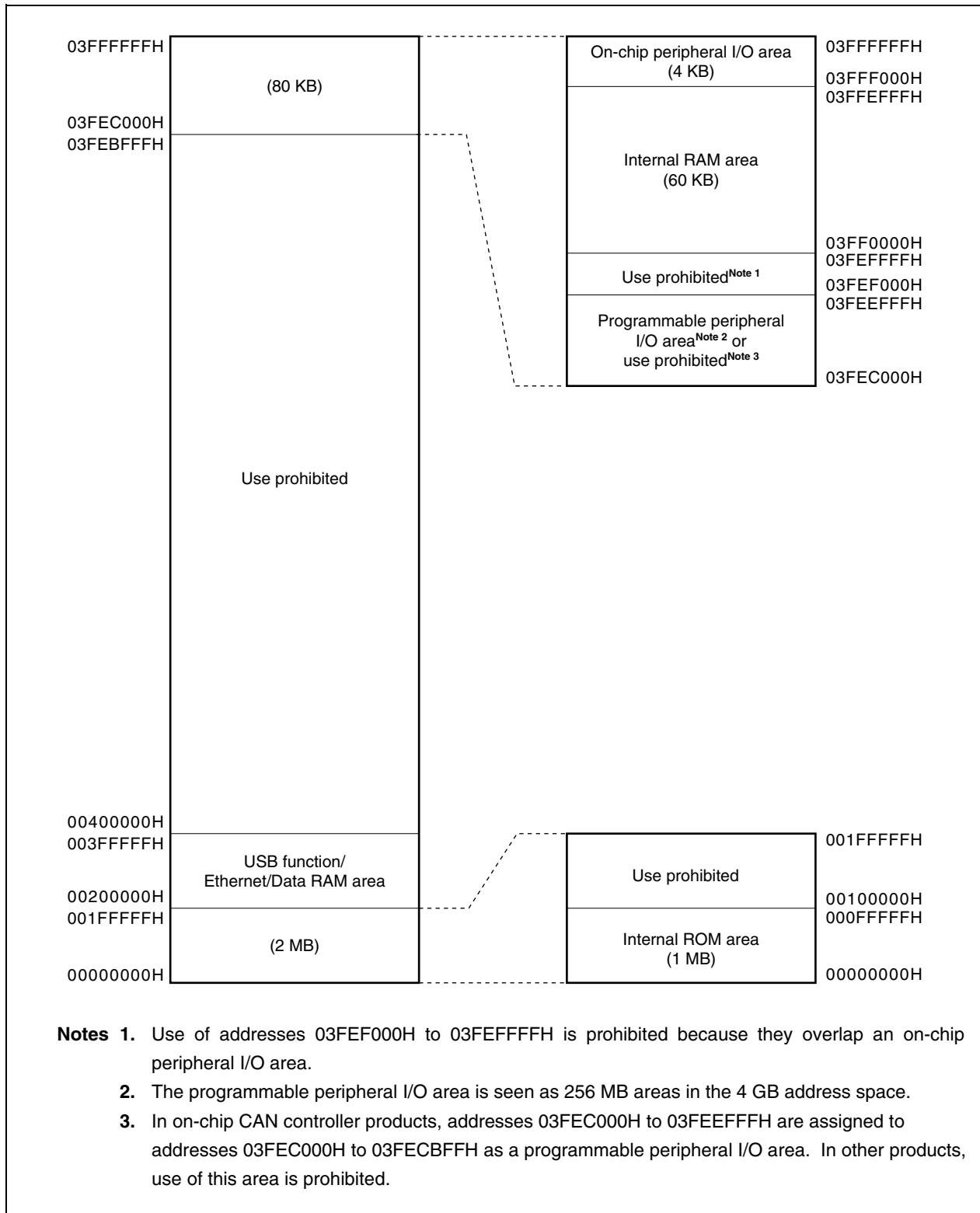

4. PORTS

The number of I/O ports of the V850ES/Jx3-E is shown below.

Product Name	V850ES/JF3-E	V850ES/JF-E	V850ES/JG3-E
Number of ports (5 V tolerant)	26 (12)	42 (28)	62 (35)

The following figure shows the basic configurations of ports.

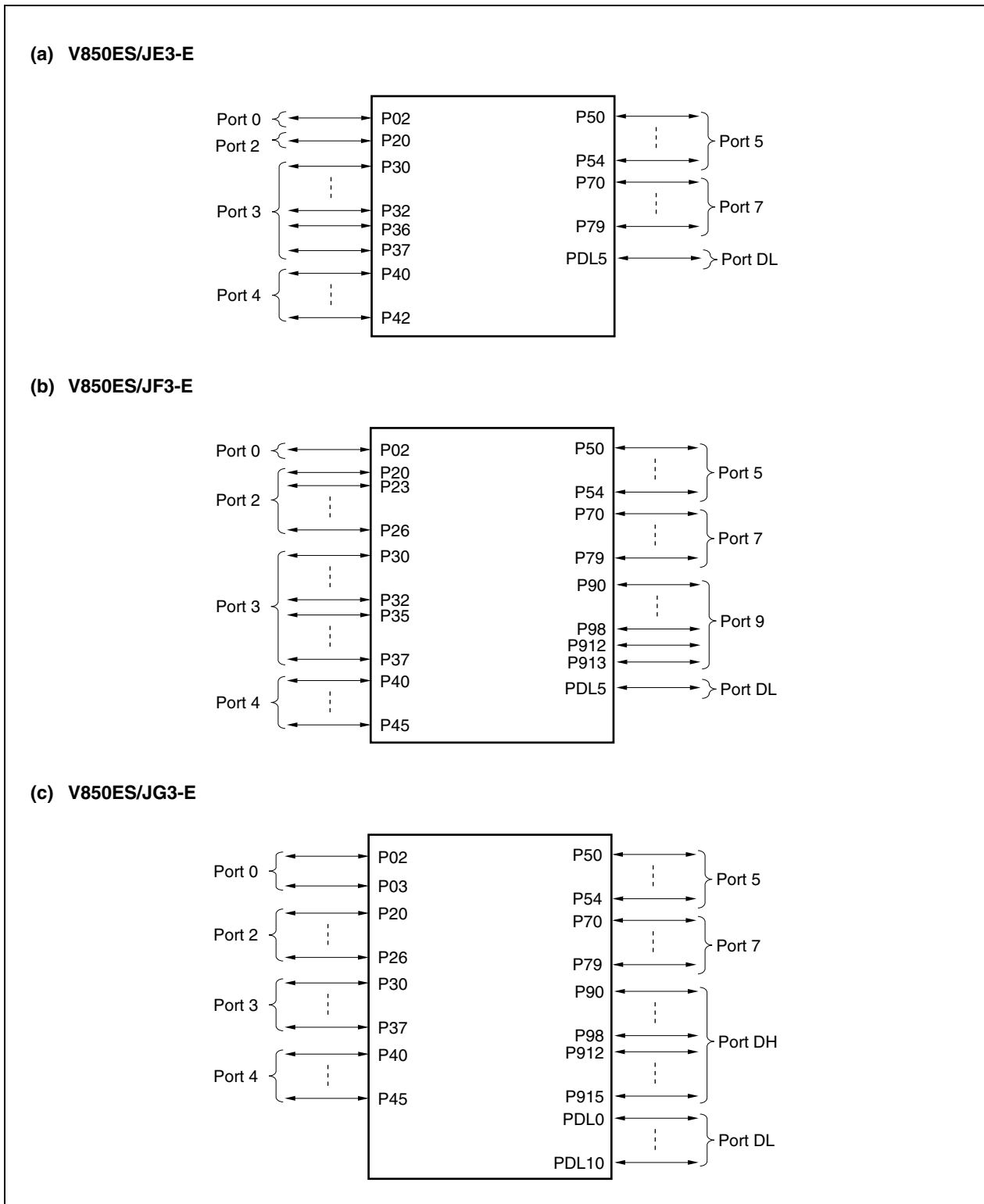

5. CLOCK GENERATION FUNCTION

The clock generation function has the following features.

- Main clock oscillator
 - PLL mode (×8): $f_x = 3$ to 6.25 MHz ($f_{xx} = 24$ to 50 MHz)
 - Clock through mode: $f_x = 3$ to 6.25 MHz ($f_{xx} = 3$ to 6.25 MHz)
- Subclock oscillator
 - $f_{XT} = 32.768$ kHz
- Internal oscillator ($f_R = 220$ kHz)
 - Default clock of watchdog timer
 - Sampling clock for clock monitor function of the main clock oscillator
 - Can be used as the internal system clock after the main clock is stopped
- Internal system clock generation
 - 7 levels (f_{xx} , $f_{xx}/2$, $f_{xx}/4$, $f_{xx}/8$, $f_{xx}/16$, $f_{xx}/32$, f_{XT})
- Peripheral clock generation
- Clock output function

The following figure shows the configuration of the clock generation function.

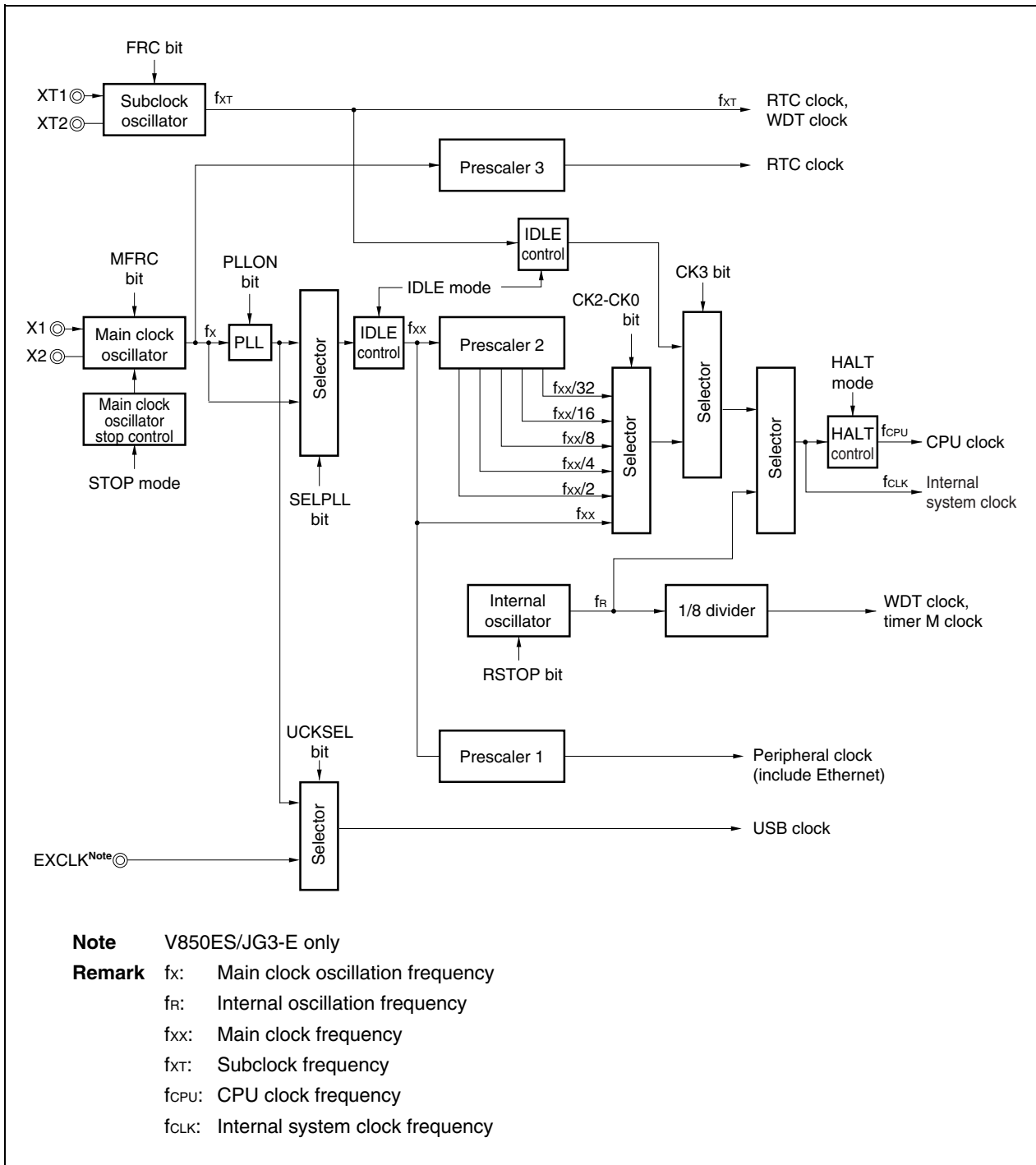

6. 16-BIT TIMER/EVENT COUNTER AA (TAA)

The number of TAA of the V850ES/Jx3-E is shown below.

Product Name	V850ES/JF3-E	V850ES/JF-E	V850ES/JG3-E
Number of channel	5 channels (TAA0 to TAA4 ^{Note})	5 channels (TAA0 to TAA4)	5 channels (TAA0 to TAA4)
Number of timer output	4	7	10

Note TAA2 and TAA3 have Interval timer function only.

The timer/counter function has the following features.

- 16 bit timer/counter (TAA_n)
- Clock selection: 8 ways
- Capture/trigger input pins (TIAA_{n0}, TIAA_{n1}): 2
- External event count input pin^{Note}: 1
- External trigger input pin^{Note}: 1
- Timer/counter: 1
- Capture/compare registers: 2
(32-bit capture function available by using a cascade connection with timer AA.)
- Capture/compare match interrupt request signals: 2
- Timer output pins (TOAA_{n0}, TOAA_{n1}): 2

The TAA_n function has the following features.

- Interval timer
- External event counter
- External trigger pulse output
- One-shot pulse output
- PWM output
- Free-running timer
- Pulse width measurement
- Timer tuning function
- Simultaneous start function

Note The external event count input pin and external trigger input pin also function as the capture trigger input pin (TIAA_{n0}).

Remark n = 0 to 4

The following figure shows the configuration of TAA.

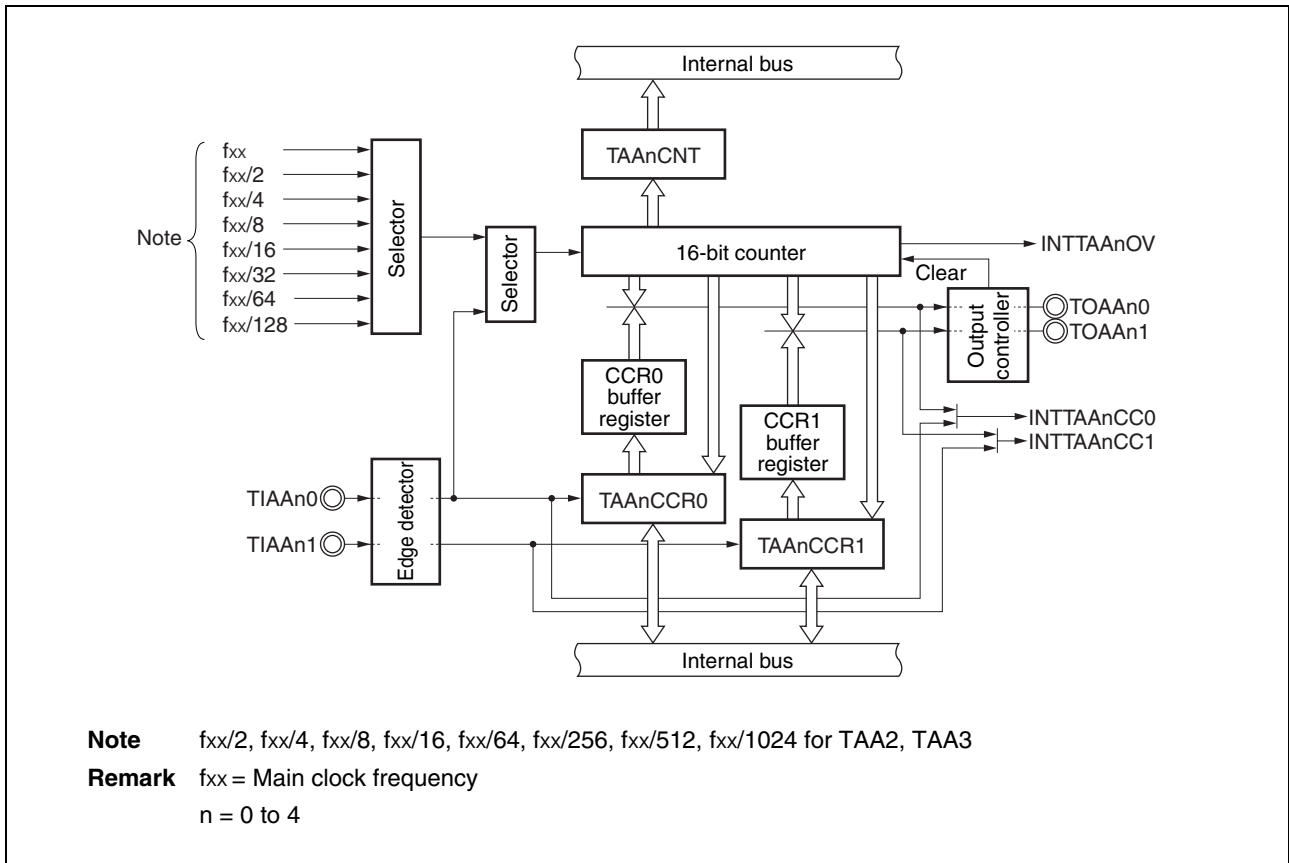

7. 16-BIT TIMER/EVENT COUNTER AB (TAB)

The number of TAB of the V850ES/Jx3-E is shown below.

Product Name	V850ES/JF3-E	V850ES/JF-E	V850ES/JG3-E
Number of channel	1 channel (TAB1 ^{Note})	1 channel (TAB1)	1 channel (TAB1)
Number of timer output	-	4	4

Note Interval timer function only.

The TAB function has the following features.

- 16-bit timer/counter (TAB1)
- Clock selection: 8 ways
- Capture/trigger input pins (TIAB10 to TIAB13): 4
- External event count input pin (EVTAB1): 1
- External trigger input pin (TRGAB1): 1
- Timer/counter: 1
- Capture/compare registers: 4
- Capture/compare match interrupt request signals: 4
- Timer output pins (TOAB10 to TOAB13): 4

The TAB1 function has the following features.

- Interval timer
- External event counter
- External trigger pulse output
- One-shot pulse output
- PWM output
- Free-running timer
- Pulse width measurement
- Triangular wave PWM output
- Timer tuning function

The following figure shows the configuration of TAB.

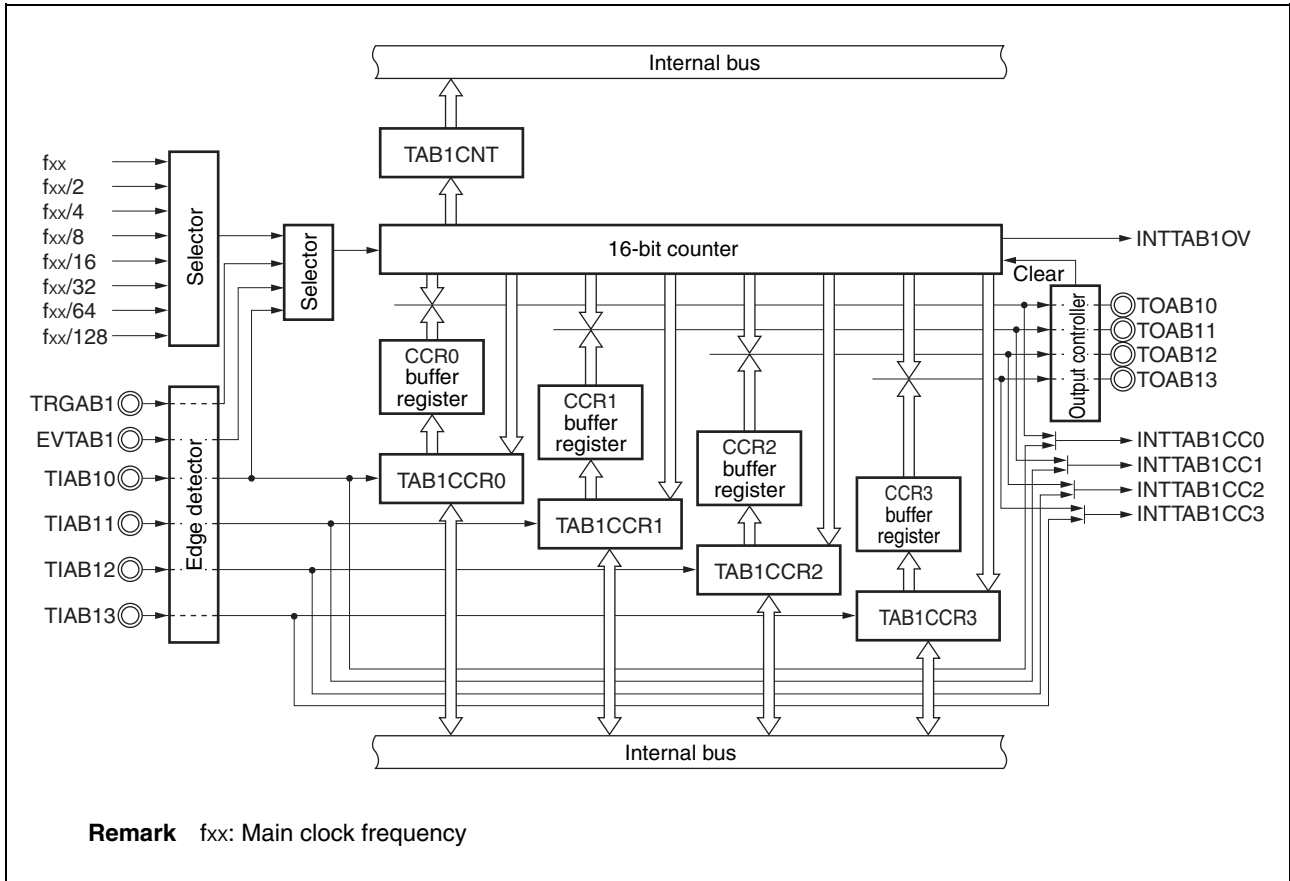

8. 16-BIT TIMER/EVENT COUNTER T (TMT)

The number of TAB of the V850ES/Jx3-E is shown below.

Product Name	V850ES/JF3-E	V850ES/JF-E	V850ES/JG3-E
Number of channel	1 channel (TMT0 ^{Note})	1 channel (TMT0)	1 channel (TMT0)
Number of timer output	-	2	2

Note Interval timer function only.

The TMT function has the following features.

- 16 bit timer/counter (TMT)
- Clock selection: 8 ways
- Capture/trigger input pins (TIT00, TIT01) : 2
- External event count input pin^{Note 1} : 1
- Encoder input pin (TENC00, TENC01) : 2
- Encoder clear input pin (TECR0) : 1
- External trigger input pin^{Note 1}: 1
- Timer/counter: 1
- Capture/compare registers: 2
- Capture/compare match interrupt request signals: 2
- Timer output pins (TOT00, TOT01) : 2

The TMT function has the following features^{Note 2}.

- Interval timer
- External event counter
- External trigger pulse output
- One-shot pulse output
- PWM output
- Free-running timer
- Pulse width measurement
- Triangular wave PWM output
- Encoder count function

Notes1. The external trigger input pin and the external event count input pin also function as the encoder input pin (TENC00)

2. The TMT0 function of V850ES/JE3-E is only Interval timer.

The following figure shows the configuration of TMT.

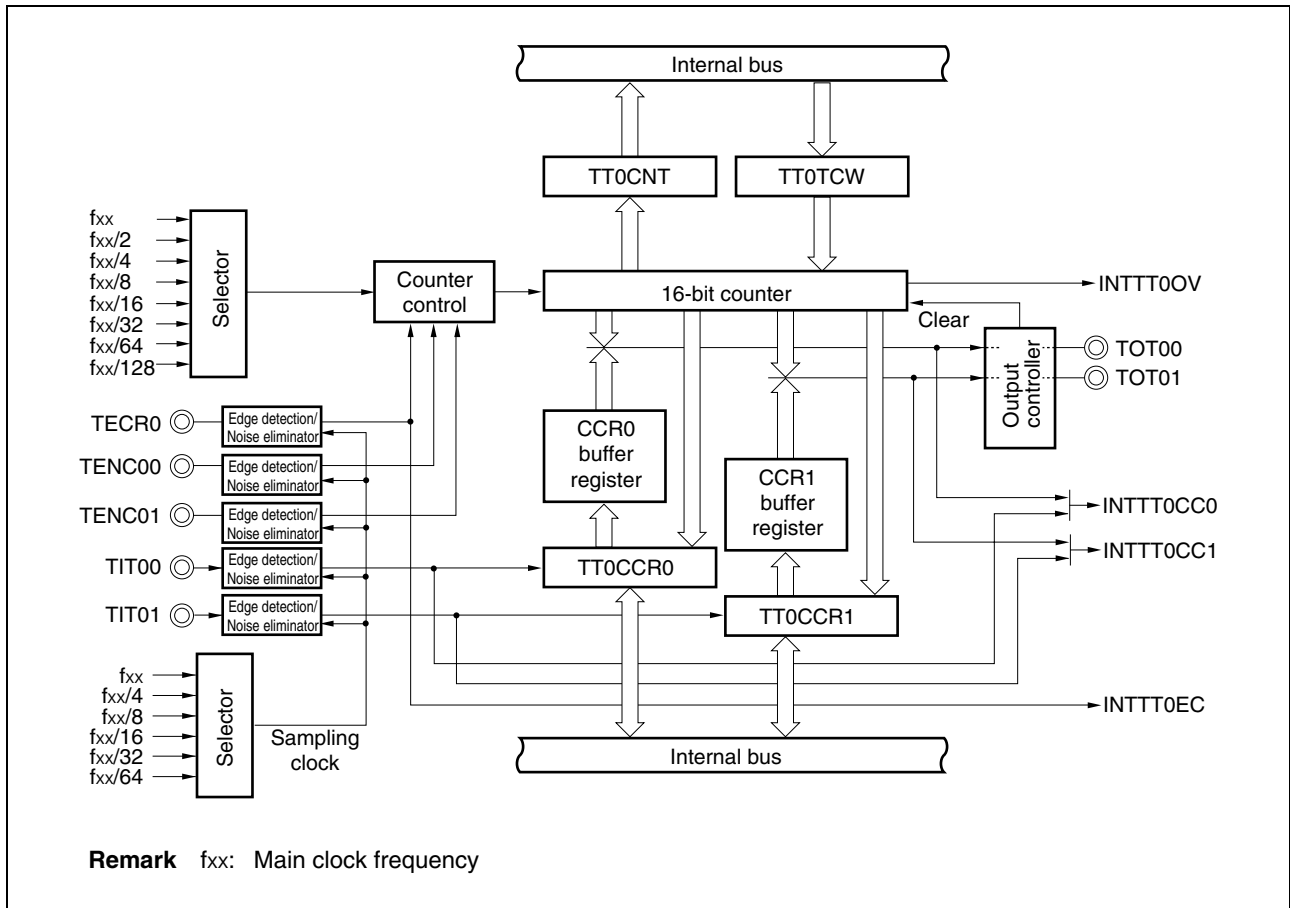

9. 16-BIT INTERVAL TIMER M (TMM)

The number of TMM of the V850ES/Jx3-E is shown below.

Product Name	V850ES/JF3-E	V850ES/JF-E	V850ES/JG3-E
Number of channel	4 channels (TMM0 to TMM3)	4 channels (TMM0 to TMM3)	4 channels (TMM0 to TMM3)

The TMM function has the following features.

- Interval function
- Clock selection: 8 ways
- 16 bit counter × 1 (Not available to counter lead in timer count operation)
- Compare register × 1 (Not available to write compare register in timer count operation)
- Compare match interrupt × 1

The following figure shows the configuration of TMM.

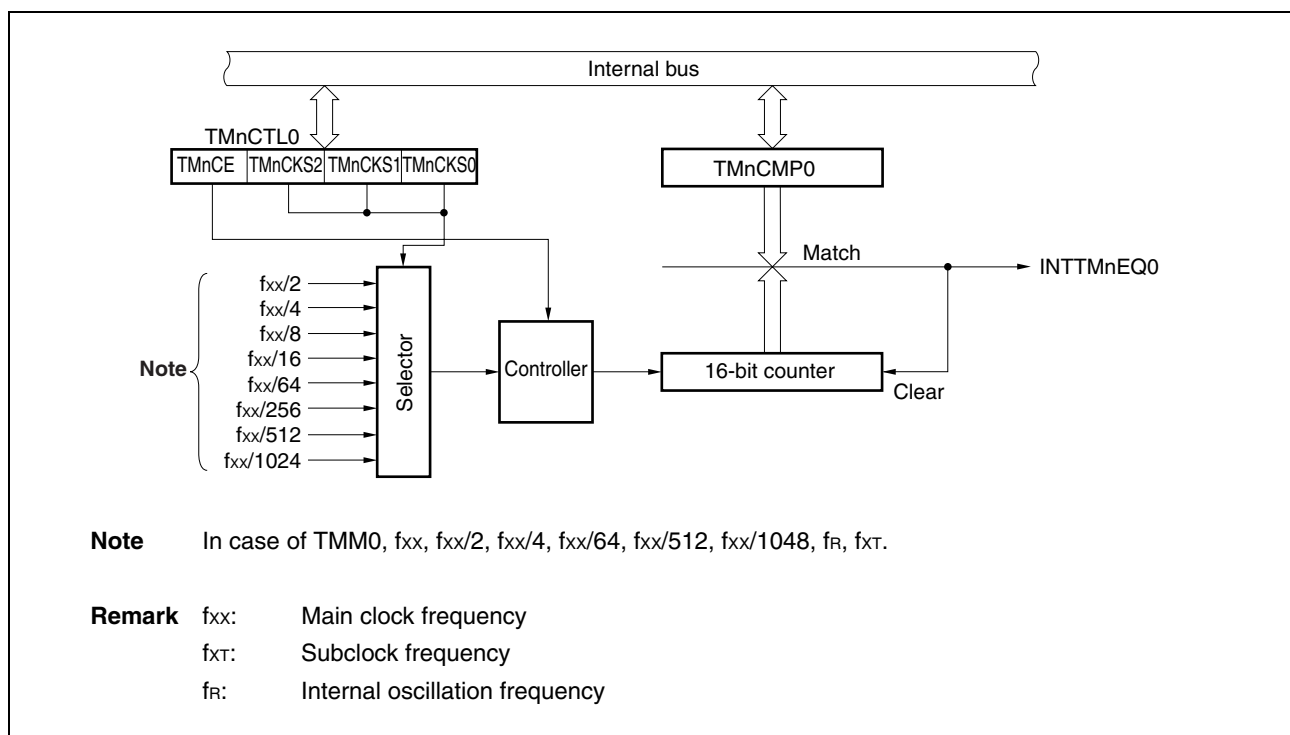

10. MOTOR CONTROL FUNCTION

In the V850ES/JF3-E and V850ES/JG3-E, one channel of motor control function is provided.

Timer AB1 (TAB) and the TAB option (TABOP) can be used as an inverter function that controls a motor.

It performs a tuning operation with timer AA4 (TAA4) and A/D conversion of the A/D converter can be started when the value of TAB matches the value of TAA4. The following operations can be performed as motor control functions.

- 6-phase PWM output function with 16-bit resolution (with dead-timer, for upper and lower arms)
- Timer tuning operation function (tunable with TAA4)
- Cycle setting function (cycle can be changed during operation of crest or valley interrupt)
- Compare register rewriting: Anytime rewrite, batch rewrite, or intermittent rewrite
(selectable during TAB operation)
- Interrupt and transfer culling functions
- Dead-time setting function
- A/D trigger timing function of the A/D converter (four types of timing can be generated)
- 0% output and 100% output available
- 0% output and 100% output selectable by crest interrupt and valley interrupt
- Forced output stop function
 - At valid edge detection by external pin input (INTP06/TOAA1OFF, INTP18/TOAB1OFF)
 - When stoppage of the main clock oscillation is detected by clock monitor function

The following figure shows the configuration of motor control function.

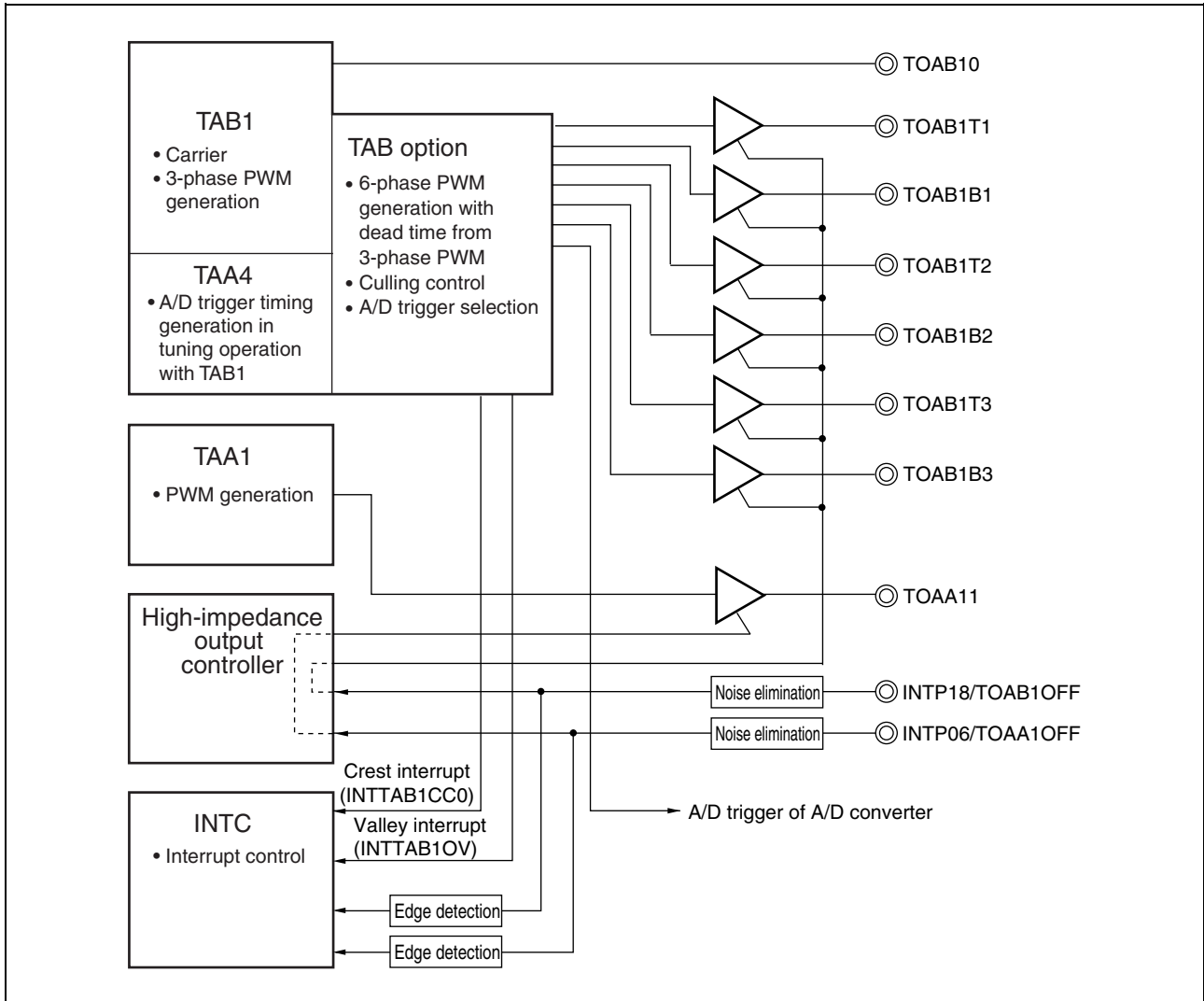

11. REAL-TIME COUNTER

In the V850ES/Jx3-E, one channel of real-time counter is provided.

The real-time counter has the following features.

- It has counters for year, month, week, day, hours, minutes and seconds, and it can count up to 99 years.
- The year, month, week, day, hour, minute and second counters show the count in BCD code^{Note 1}.
- Alarm interrupt function
- Fixed-cycle interrupt function (cycle: 1 month to 0.5 seconds)
- Interval interrupt function (cycle: 1.95 to 125 ms)
- 1 Hz pin output
- 32.768 kHz pin output
- 512 Hz or 16.384 kHz pin output
- Watch error correction function
- Subclock operation or main clock operation^{Note 2} selectable

Notes 1. BCD (binary-coded decimal) code is the code that represents each digit of a decimal number in 4-bit binary numerals.

2. The main clock can be divided into 32.768 kHz f_{BRG} with the baud rate generator dedicated to the real-time counter.

The following figure shows the configuration of real-time timer.

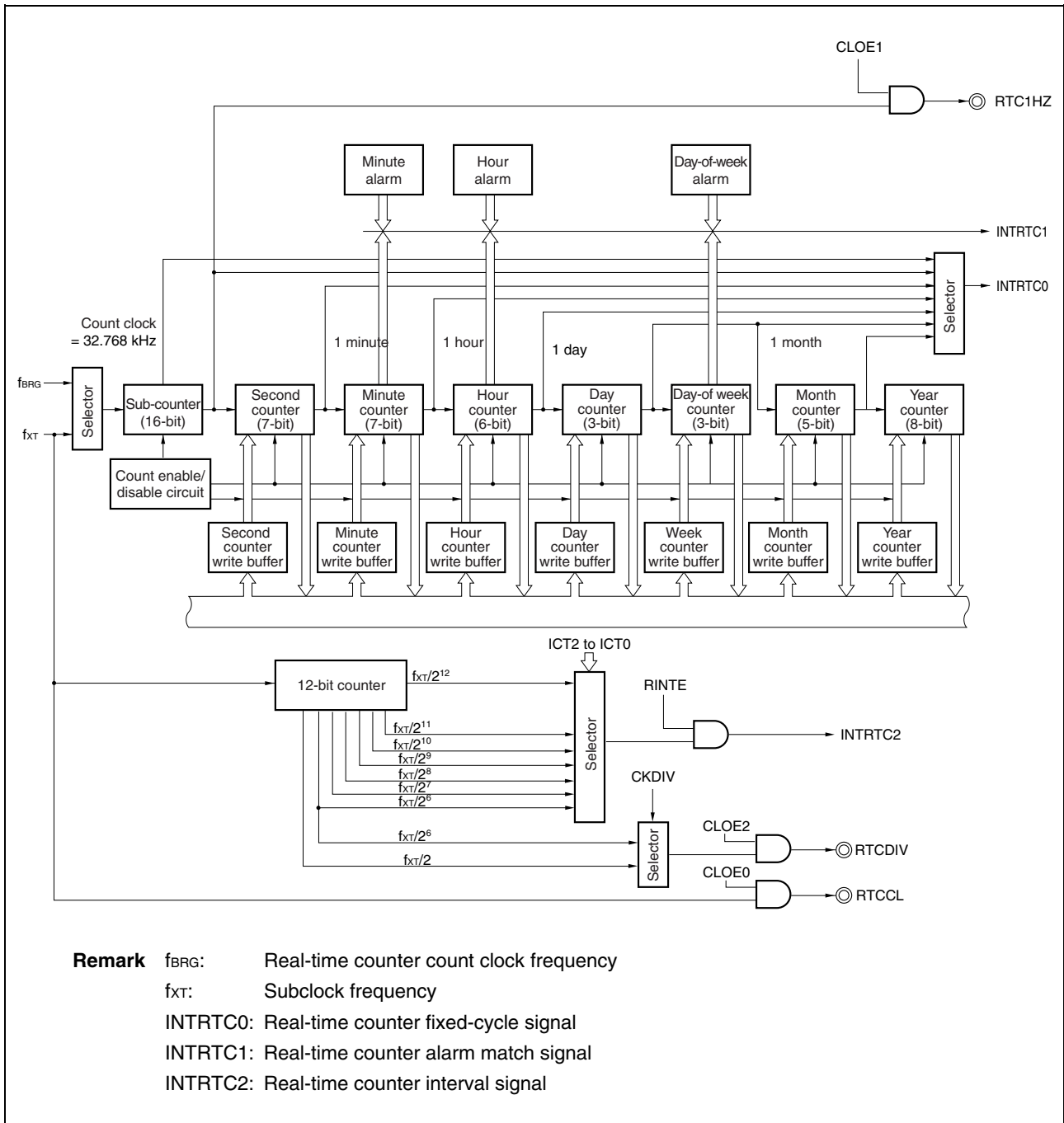

12. WATCHDOG TIMER 2 FUNCTIONS

In the V850ES/Jx3-E, one channel of watchdog timer 2 is provided.

The watchdog timer has the following functions.

- Reset mode: Reset operation upon overflow of watchdog timer (generates the WDT2RES signal)
- Non-maskable interrupt request mode: NMI operation upon overflow of watchdog timer (generates the INTWDT2 signal)

The following figure shows the configuration of the watchdog timer functions.

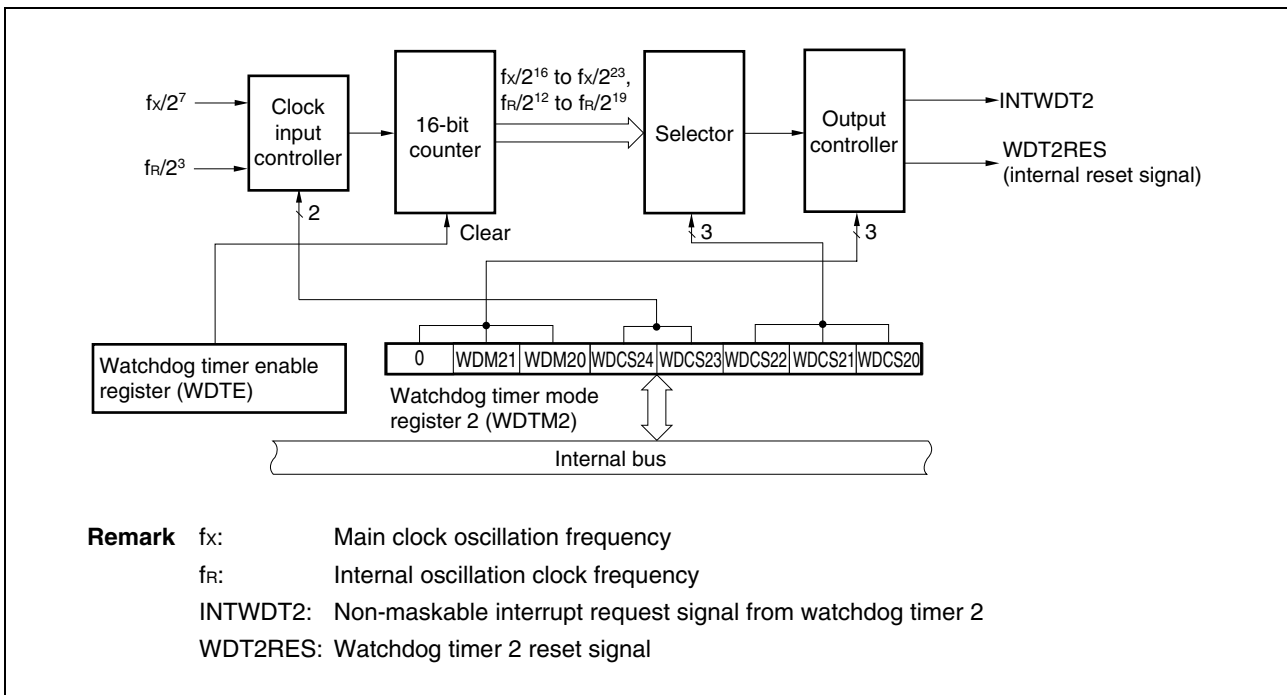

13. REAL-TIME OUTPUT FUNCTION (RTO)

In the V850ES/Jx3-E, one channel of real-time output is provided.

The RTO has the following features.

- 6-bit real-time output port: 1 channel
- The real-time output port can be set to the port mode or real-time output port mode in 1-bit units.

The RTO has the following configurations.

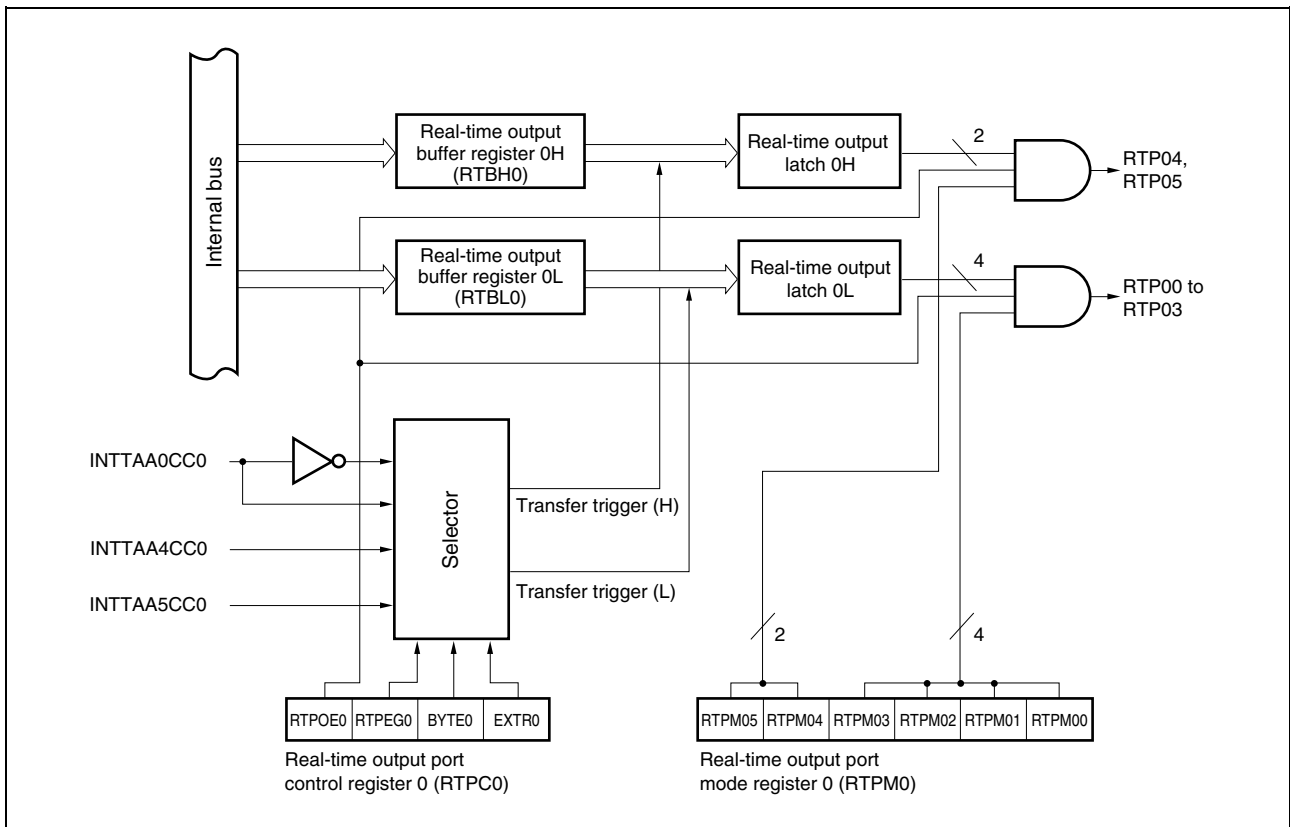

14. A/D CONVERTER

An A/D converter unit with ten channels is provided in the V850ES/Jx3-E.

The A/D converter has the following features.

- 10-bit resolution
- 10 channels
- Successive approximation method
- Operating voltage: $AV_{REF0} = 3.0$ to 3.6 V
- Analog input voltage: 0 V to AV_{REF0}
- The following functions are provided as operation modes.
 - Continuous select mode
 - Continuous scan mode
 - One-shot select mode
 - One-shot scan mode
- The following functions are provided as trigger modes.
 - Software trigger mode
 - External trigger mode (external, 1)
 - Timer trigger mode
- Power-fail monitor function (conversion result compare function)

The following figure shows the configuration of the A/D converter.

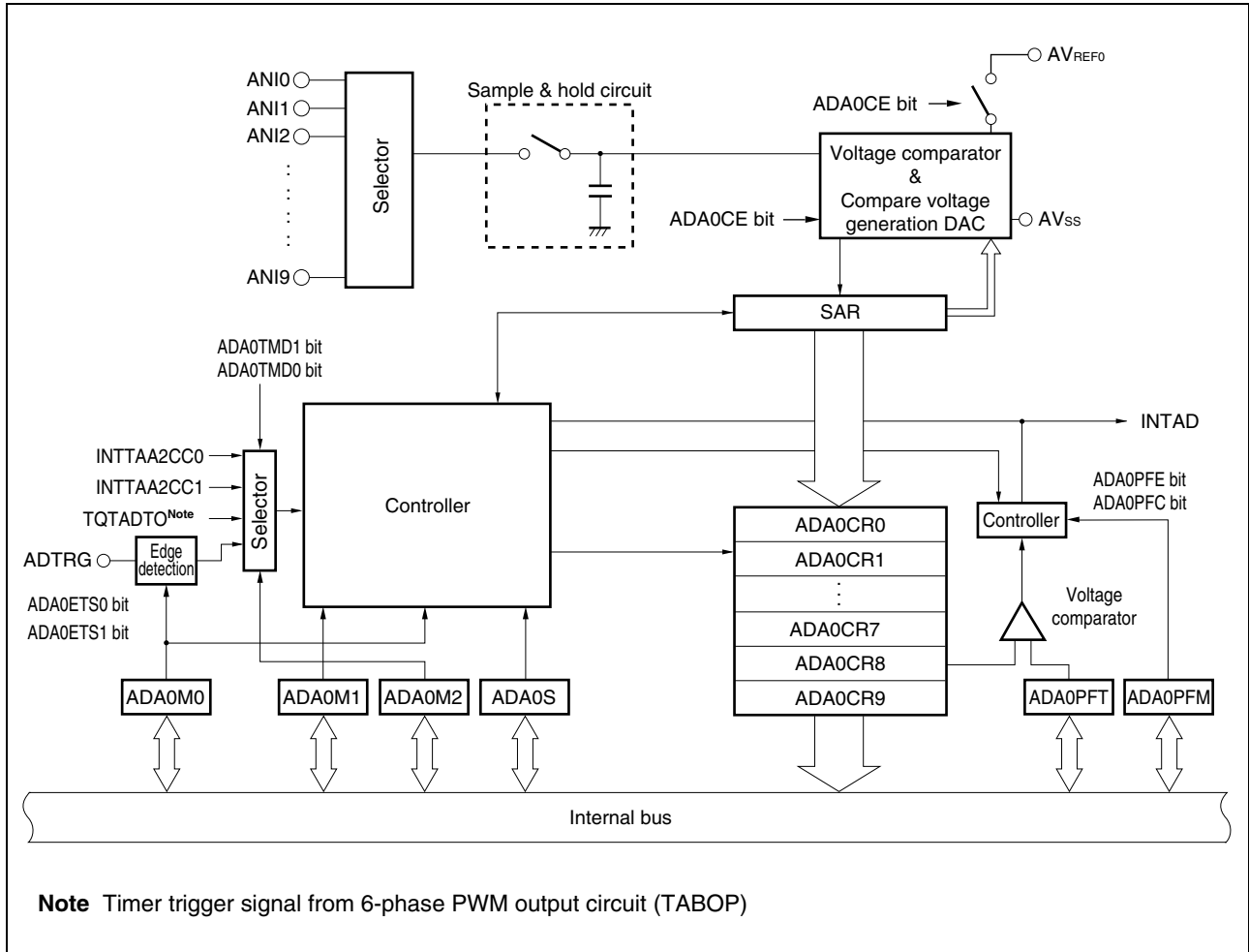

15. ASYNCHRONOUS SERIAL INTERFACE C (UARTC)

The number of UARTC of the V850ES/Jx3-E is shown below.

Product Name	V850ES/JF3-E	V850ES/JF-E	V850ES/JG3-E
Number of channel	3 channels (UARTC0, UARTC2 and UARTC3)	4 channels (UARTC0 to UARTC3)	4 channels (UARTC0 to UARTC3)

The UARTC has the following features.

- Transfer rate: 300 bps to 3.125 Mbps (using internal system clock of 24 MHz and dedicated baud rate generator)
- Full-duplex communication: On-chip UARTCn receive data register (UCnRX)
On-chip UARTCn transmit data register (UCnTX)
- 2-pin configuration: TXDCn: Transmit data output pin
RXDCn: Receive data input pin
- Reception error detect function
 - Parity error
 - Framing error
 - Overrun error
 - LIN communication data consistency error detect function
 - SBF reception success detect function
- Interrupt sources: 2 types
 - Reception completion interrupt (INTUCnR): This interrupt occurs upon transfer of receive data from the receive shift register to receive data register after serial transfer completion, in the reception enabled status.
 - Transmission enable interrupt (INTUCnT): This interrupt occurs upon transfer of transmit data from the transmit data register to the transmit shift register in the transmission enabled status.
- Character length: 7, 8, 9 bits
- Parity function: Odd, even, 0, none
- Transmission stop bit: 1, 2 bits
- On-chip dedicated baud rate generator
- MSB-/LSB-first transfer selectable
- Transmit/receive data inverted input/output possible
- SBF (Sync Break Field) transmission/reception in the LIN (Local Interconnect Network) communication format possible
 - 13 to 20 bits are selectable for SBF transmission
 - Recognition of 11 bits or more possible for SBF reception in LIN format
 - SBF reception flag provided

The following figure shows the configuration of UARTC.

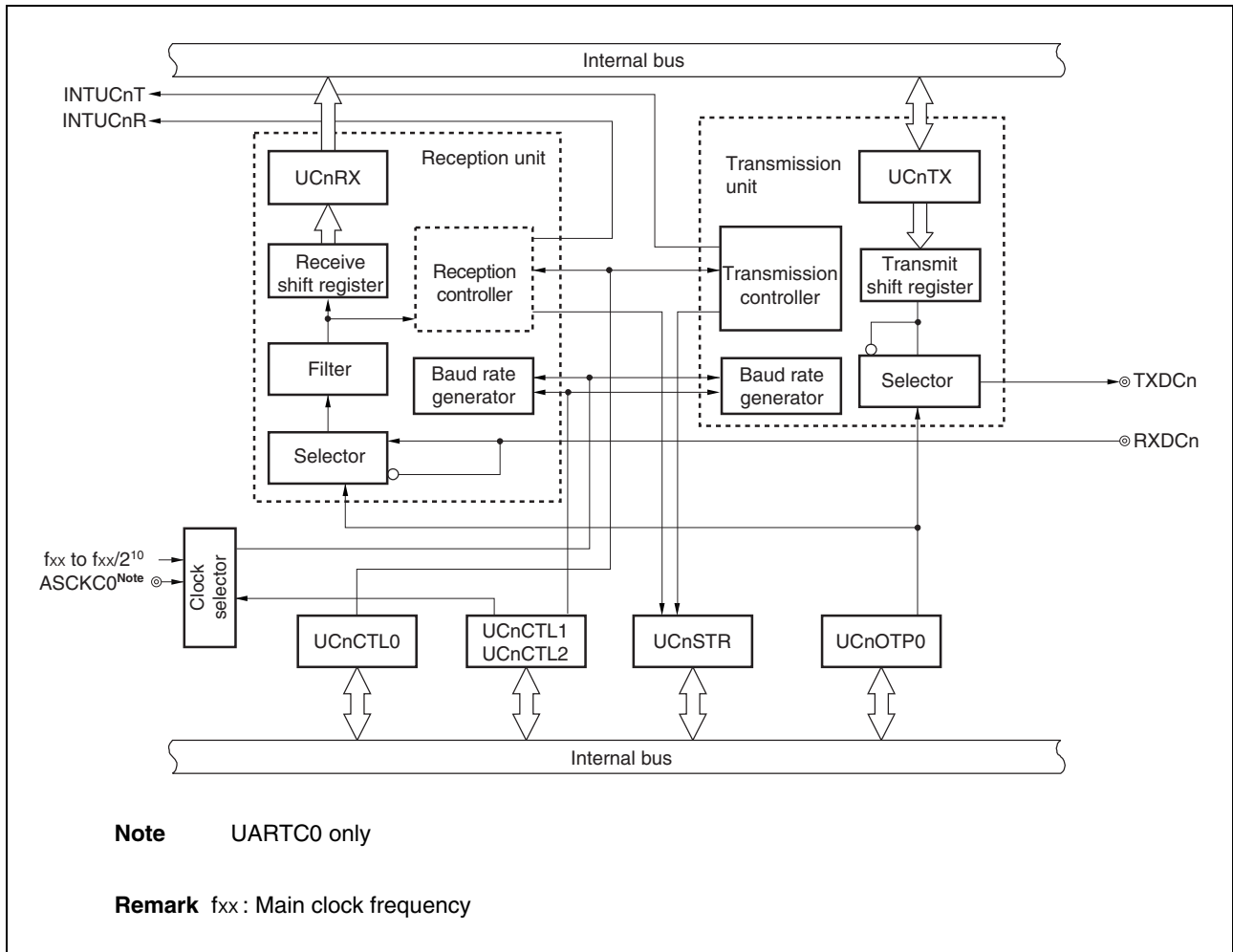

16. CLOCKED SERIAL INTERFACE F (CSIF)

The number of CSIF of the V850ES/Jx3-E is shown below.

Product Name	V850ES/JF3-E	V850ES/JF-E	V850ES/JG3-E
Number of channel	2 channels (CSIF0 and CSIF2)	3 channels (CSIF0 to CSIF2)	5 channels (CSIF0 to CSIF4)

- Transfer rate: 8 Mbps max. (f_{xx} = 50 MHz, using internal clock)
- Master mode and slave mode selectable
- 8-bit to 16-bit transfer, 3-wire serial interface
- Interrupt request signals (INTCFnT, INTCFnR)
- Serial clock and data phase switchable
- Transfer data length selectable in 1-bit units between 8 and 16 bits
- Transfer data MSB-first/LSB-first switchable
- 3-wire
 - SOFn: Serial data output
 - SIFn: Serial data input
 - SCKFn: Serial clock I/O

Transmission mode, reception mode, and transmission/reception mode specifiable

The following figure shows the configuration of CSIF.

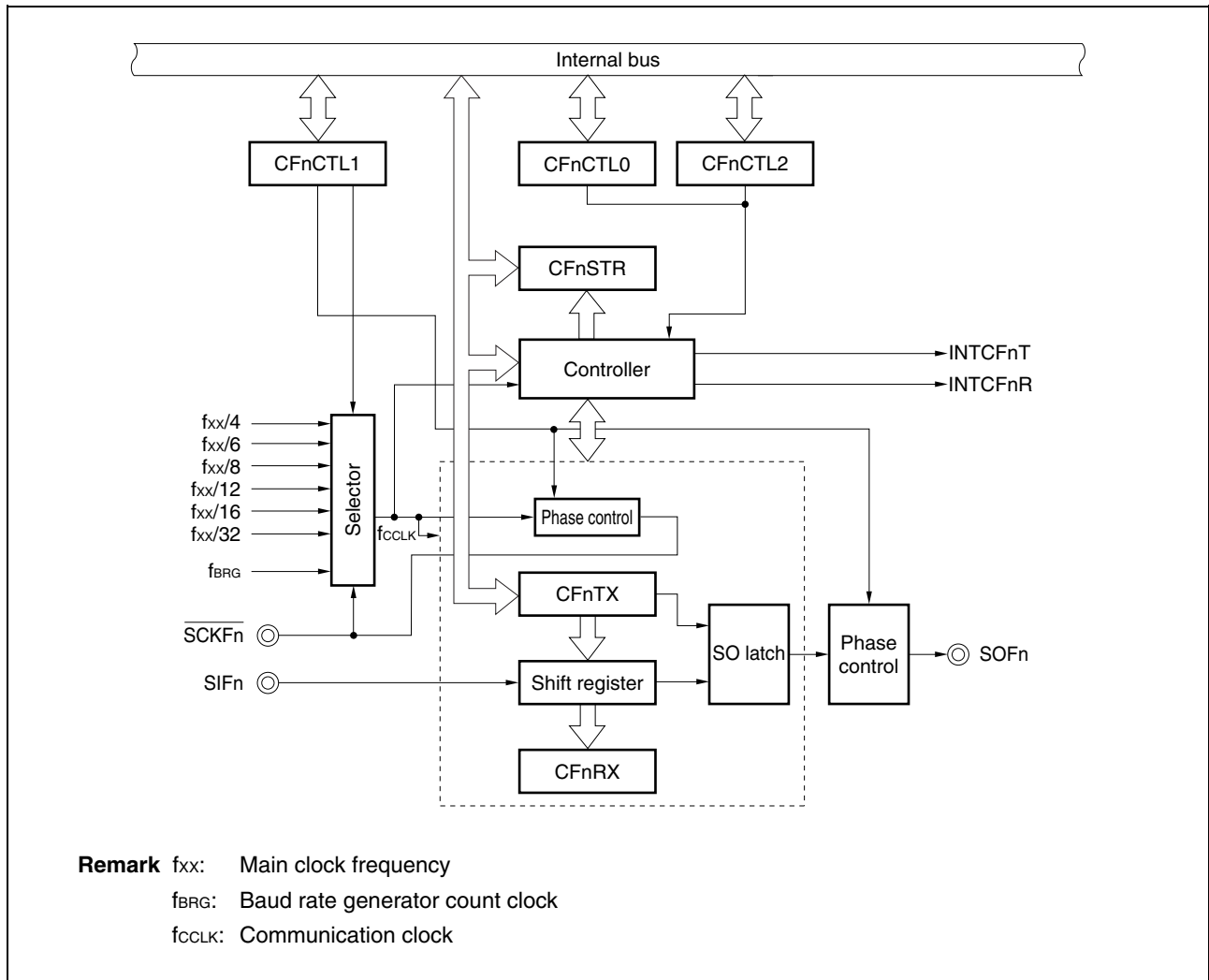

17. I²C BUS

The number of I²C bus of the V850ES/Jx3-E is shown below.

Product Name	V850ES/JF3-E	V850ES/JF-E	V850ES/JG3-E
Number of channel	2 channels (I ² C01 and I ² C02)	3 channels (I ² C00 to I ² C02)	3 channels (I ² C00 to I ² C02)

- Transfer rate: Standard mode (100 kbps max.)/high-speed mode (400 kbps max.)
- Conforms to I²C bus format (multimaster supported)
- 2-wire SCL0n: Serial clock pin
SDA0n: Serial data bus pin

The following figure shows the configuration of I²C.

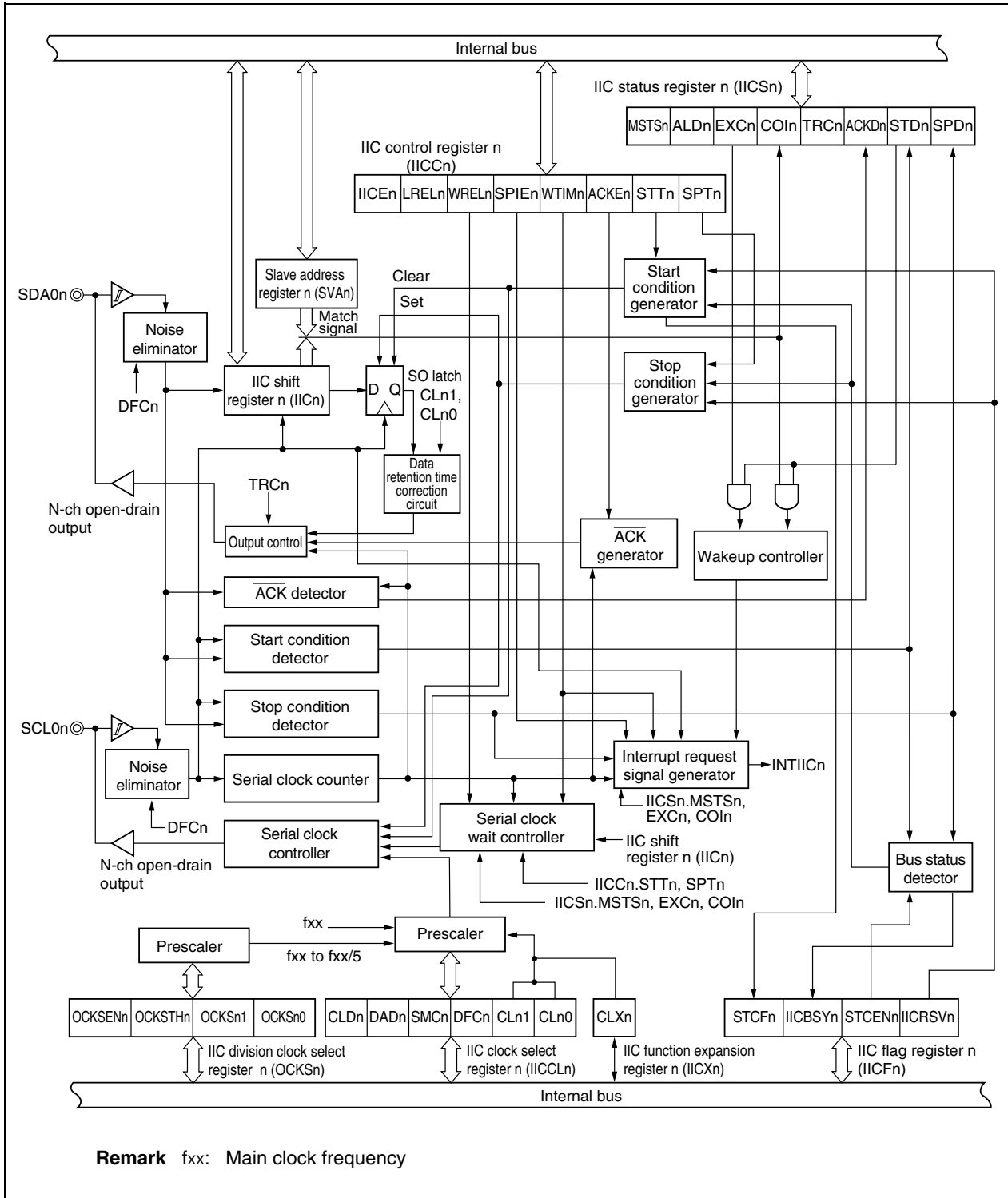

18. CAN CONTROLLER

In the μPD70F3829, 70F3833, 70F3837, one channel of CAN controller is provided.

- Compliant with ISO 11898 and tested according to ISO/DIS 16845 (CAN conformance test)
- Standard frame and extended frame transmission/reception enabled
- Transfer rate: 1 Mbps max. (CAN clock input ≥ 8 MHz)
- 32 message buffers/channels
- Receive/transmit history list function
- Automatic block transmission function
- Multi-buffer receive block function
- Mask setting of four patterns is possible for each channel

The following figure shows the configuration of CAN controller.

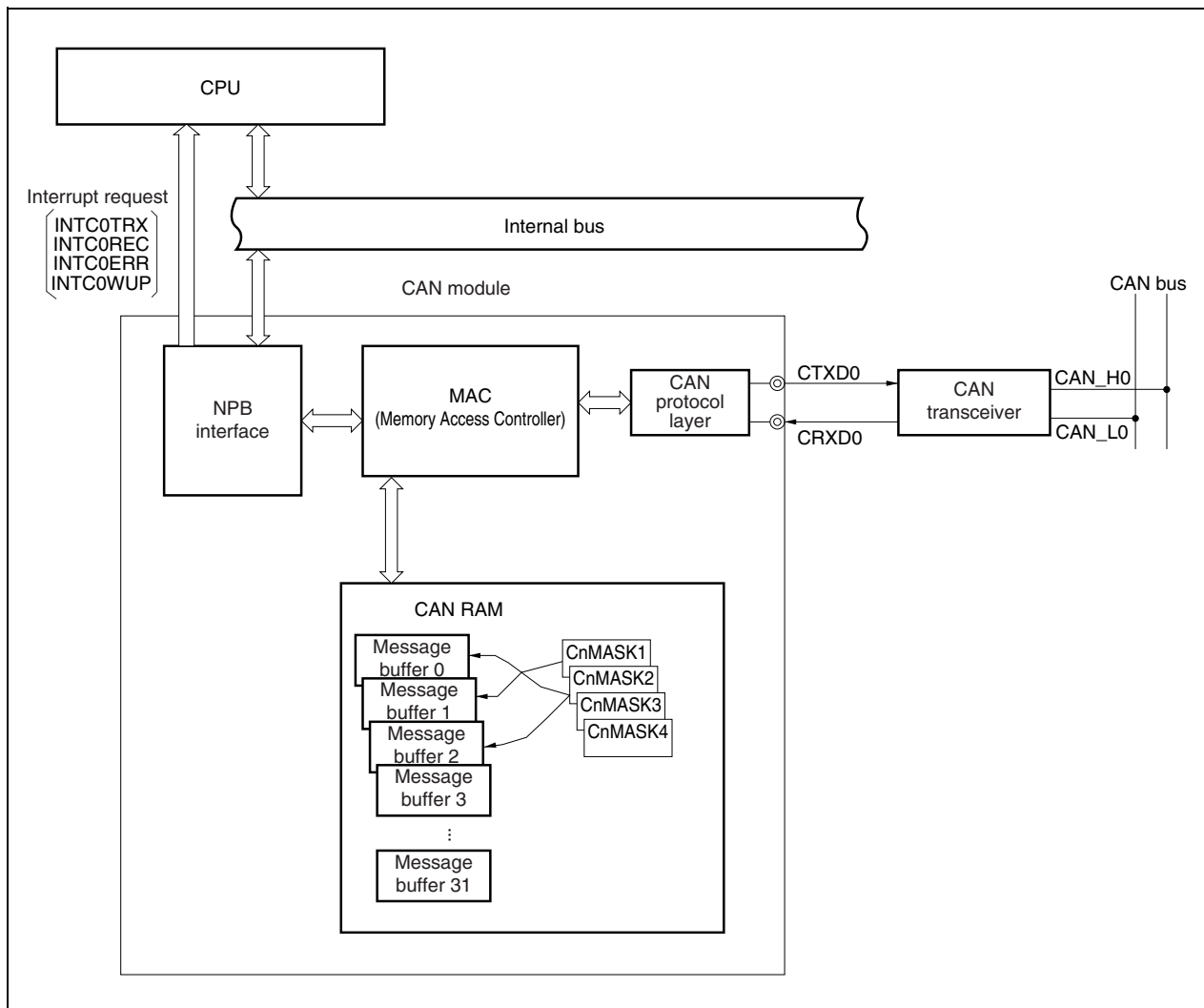

19. USB FUNCTION CONTROLLER (USBF)

In the V850ES/Jx3-E, one channel of USBF is provided.

- Conforms to the Universal Serial Bus (USB) Specification.
- USB 2.0-compatible full-speed transfer (12 Mbps) supported
- Endpoint for transfer incorporated

Endpoint Name	FIFO Size (Bytes)	Transfer Type	Remark
Endpoint0 Read	64	Control transfer	-
Endpoint0 Write	64	Control transfer	-
Endpoint1	64 × 2	Bulk 1 transfer (IN)	2-buffer configuration
Endpoint2	64 × 2	Bulk 1 transfer (OUT)	2-buffer configuration
Endpoint3	64 × 2	Bulk 2 transfer (IN)	2-buffer configuration
Endpoint4	64 × 2	Bulk 2 transfer (OUT)	2-buffer configuration
Endpoint7	8	Interrupt transfer (IN)	-

The following figure shows the configuration of USB function controller.

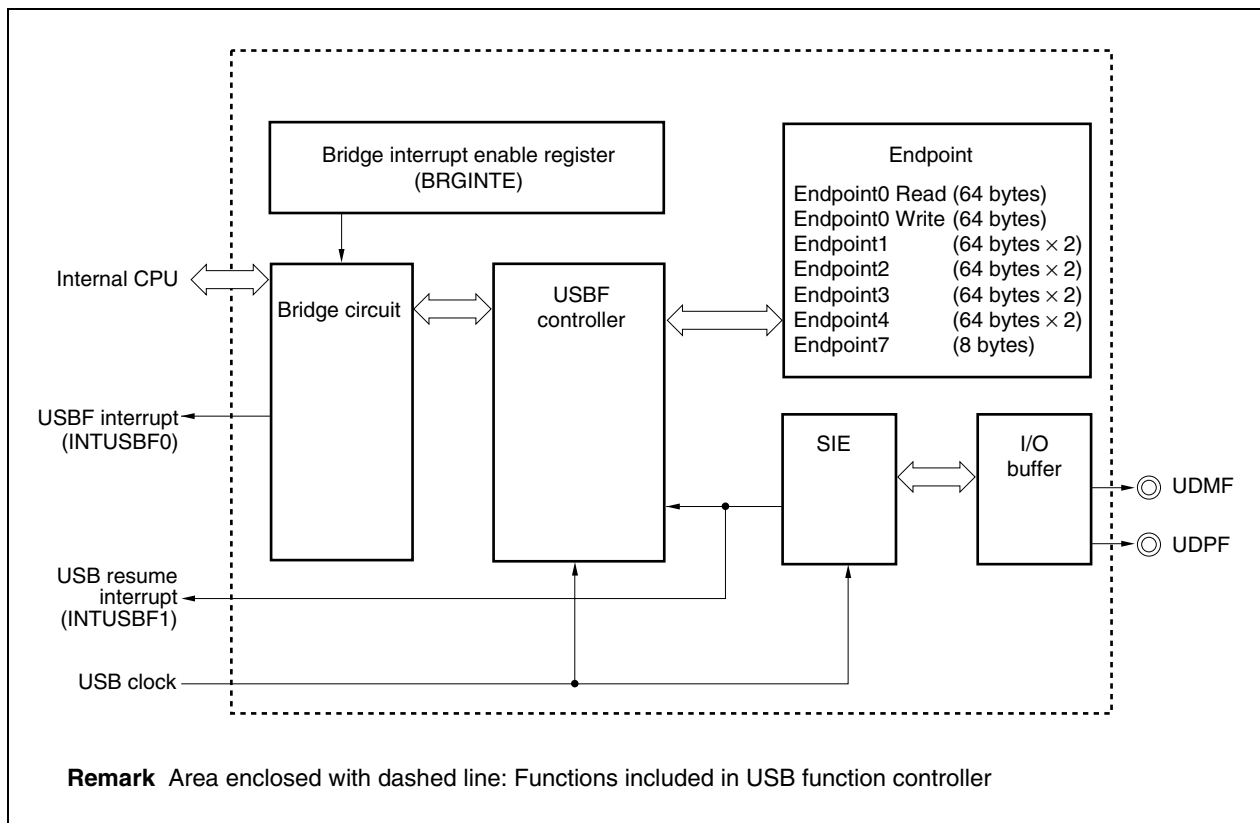

20. ETHERNET CONTROLLER

In the V850ES/Jx3-E, one channel of Ethernet controller is provided.

- 10 Mbps/100 Mbps MAC function conforming to the IEEE802.3 standard
 - Full-duplex and half-duplex communications and a flow control function are supported
 - On-chip packet filtering function based on address type
 - On-chip VLAN detection function
- Ethernet-dedicated DMA controller
 - Reception status DMA transfer possible
 - Reading (in pointer-chain format), analysis, and writing back of buffer descriptors possible
 - Interrupt control functions for packet transfers
- FIFO controller
 - Transmission/reception FIFO size: Transmission FIFO (2 KB), reception FIFO (2 KB)
 - On-chip FIFO status register
 - Interrupts occur in accordance with the transmission/reception status and FIFO status.
- MII is supported as the interface with physical-layer devices (PHY)
- On-chip reception checksum calculation function conforming to RFC1071

The following figure shows the configuration of USB function controller.

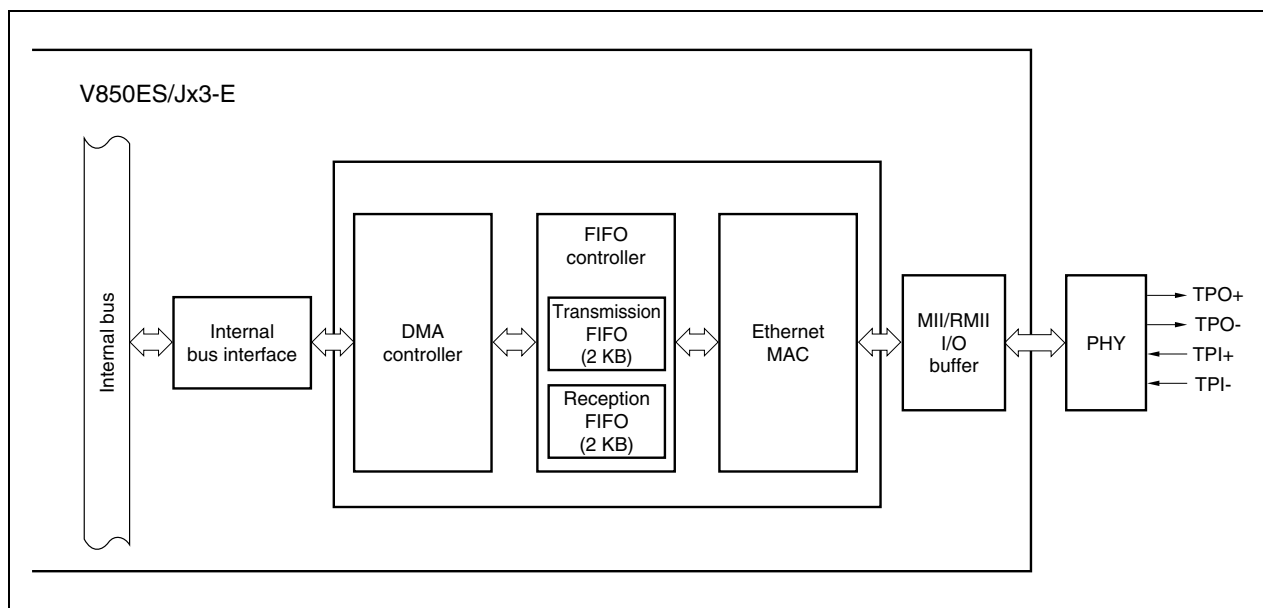

21. DMA CONTROLLER

In the V850ES/Jx3-E, four channels of DMA controller are provided.

- 4 independent DMA channels
- Transfer unit: 8/16 bits
- Maximum transfer count: 65,536 (2^{16})
- Transfer type: Two-cycle transfer
- Transfer mode: Single transfer mode
- Transfer requests
 - Request by interrupts from on-chip peripheral I/O (serial interface, timer/counter, real-time counter, A/D converter) or interrupts from external input pin
 - Requests by software trigger
- Transfer targets
 - Internal RAM \Leftrightarrow Peripheral I/O
 - Peripheral I/O \Leftrightarrow Peripheral I/O

The following figure shows the configuration of DMA controller.

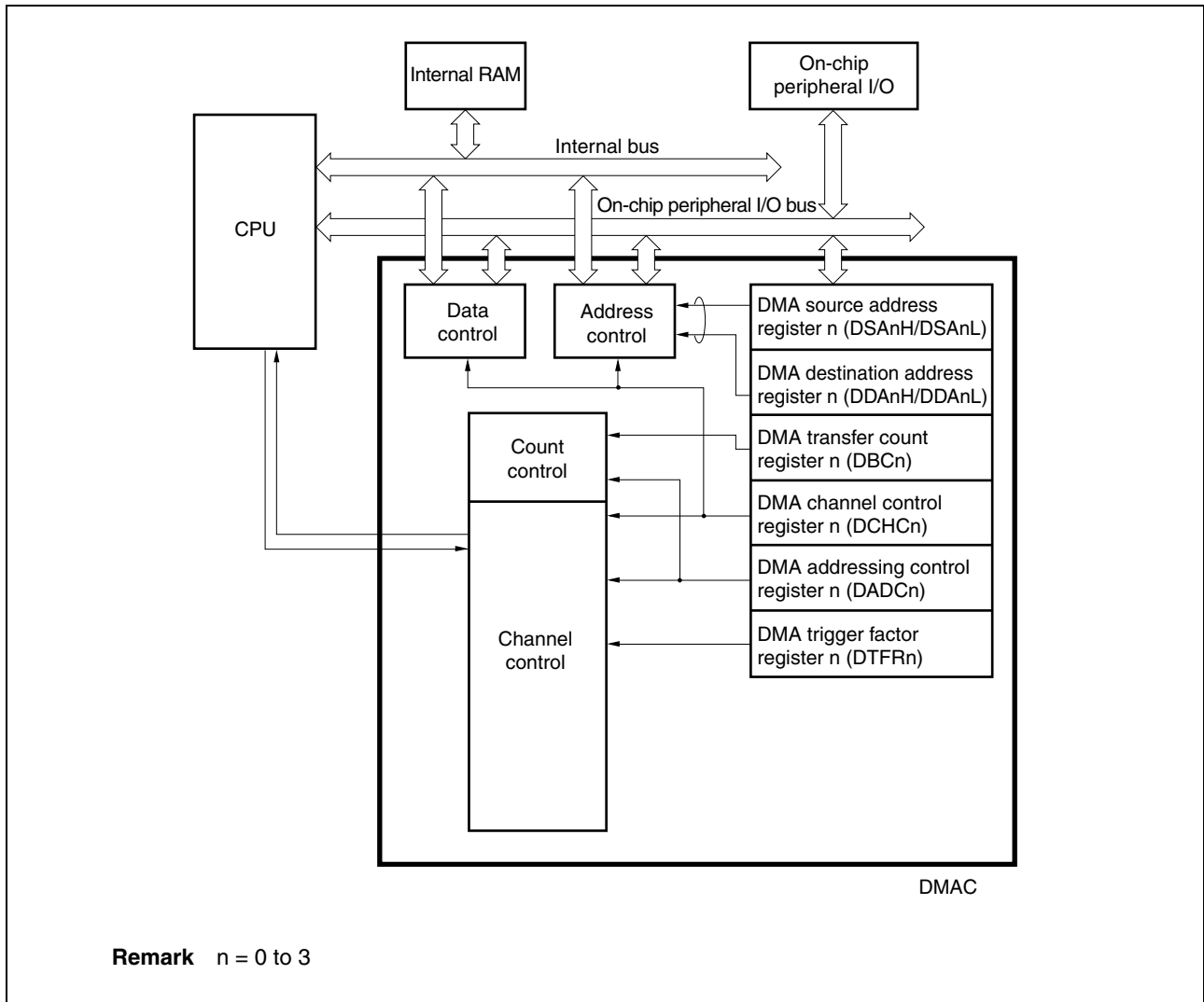

22. INTERRUPT/EXCEPTION PROCESSING FUNCTION

The features of interrupt/exception processing function is shown below.

○ Interrupts

		Internal			External		
		Non maskable	Maskable	Total	Non maskable	Maskable	Total
V850ES/JE3-E	μPD70F3826	1	53	54	1	6	7
	μPD70F3827	1	53	54	1	6	7
	μPD70F3828	1	53	54	1	6	7
	μPD70F3829	1	57	58	1	6	7
V850ES/JF3-E	μPD70F3830	1	56	57	1	18	19
	μPD70F3831	1	56	57	1	18	19
	μPD70F3832	1	56	57	1	18	19
	μPD70F3833	1	60	61	1	18	19
V850ES/JG3-E	μPD70F3834	1	60	61	1	21	22
	μPD70F3835	1	60	61	1	21	22
	μPD70F3836	1	60	61	1	21	22
	μPD70F3837	1	64	65	1	21	22

- 8 levels of programmable priorities
- Masks interrupt requests according to priority
- Masks can be specified for each maskable interrupt request.
- Noise elimination, edge detection, and valid edge specification for external interrupt request signals.

○ Exceptions

- Software exceptions: 32 sources
- Exception trap: 2 sources (illegal opcode exception, debug trap)

Interrupt/exception sources are listed in Table 22-1.

Table 22-1. Interrupt Source List (1/3)

Type	Classification	Default Priority	Name	Trigger	Generating Unit	Interrupt Control Register	JE3E	JF3E	JG3E
Reset	Interrupt	–	RESET	RESET pin input/reset input from internal source	RESET	–	√	√	√
Non-maskable	Interrupt	–	NMI	NMI pin valid edge input	Pin	–	√	√	√
		–	INTWDT2	WDT2 overflow	WDT2	–	√	√	√
Software exception	Exception	–	TRAP0n (n = 0-FH)	TRAP instruction	–	–	√	√	√
		–	TRAP1n (n = 0-FH)	TRAP instruction	–	–	√	√	√
Exception trap	Exception	–	ILGOP/DBG0	Illegal instruction code/DBTRAP instruction	–	–	√	√	√
Maskable	Interrupt	0	INTLVI	Detection of low voltage	POCLVI	LVIIC	√	√	√
		1	INTP00	Detection of external interrupt pin input edge (INTP00)	Pin	PIC0			√
		2	INTP01	Detection of external interrupt pin input edge (INTP01)	Pin	PIC1	√	√	√
		3	INTP02	Detection of external interrupt pin input edge (INTP02)	Pin	PIC2	–	–	√
		4	INTP03	Detection of external interrupt pin input edge (INTP03)	Pin	PIC3	–	√	√
		5	INTP04	Detection of external interrupt pin input edge (INTP04)	Pin	PIC4	–	√	√
		6	INTP05	Detection of external interrupt pin input edge (INTP05)	Pin	PIC5	–	√	√
		7	INTP06	Detection of external interrupt pin input edge (INTP06)	Pin	PIC6	–	√	√
		8	INTP07	Detection of external interrupt pin input edge (INTP07)	Pin	PIC7	√	√	√
		9	INTP08	Detection of external interrupt pin input edge (INTP08)	Pin	PIC8	√	√	√
		10	INTP09	Detection of external interrupt pin input edge (INTP09)	Pin	PIC9	√	√	√
		11	INTP10	Detection of external interrupt pin input edge (INTP10)	Pin	PIC10	√	√	√
		12	INTP11	Detection of external interrupt pin input edge (INTP11)	Pin	PIC11	√	√	√
		13	INTP12	Detection of external interrupt pin input edge (INTP12)	Pin	PIC12	–	√	√
		14	INTP13	Detection of external interrupt pin input edge (INTP13)	Pin	PIC13	–	√	√
		15	INTP14	Detection of external interrupt pin input edge (INTP14)	Pin	PIC14	–	√	√
		16	INTP15	Detection of external interrupt pin input edge (INTP15)	Pin	PIC15	–	√	√
		17	INTP16	Detection of external interrupt pin input edge (INTP16)	Pin	PIC16	–	√	√
		18	INTP17	Detection of external interrupt pin input edge (INTP17)	Pin	PIC17	–	√	√
		19	INTP18	Detection of external interrupt pin input edge (INTP18)	Pin	PIC18	–	√	√
		20	INTP19	Detection of external interrupt pin input edge (INTP19)	Pin	PIC19	–	√	√
		21	INTP20	Detection of external interrupt pin input edge (INTP20)	Pin	PIC20	–	–	√
		32	INTTAB1OV	TAB1 overflow	TAB1	TAB1OVIC	√	√	√
		33	INTTAB1CC0	TAB1 capture 0/compare 0 match	TAB1	TAB1CCIC0	√	√	√
		34	INTTAB1CC1	TAB1 capture 1/compare 1 match	TAB1	TAB1CCIC1	√	√	√
		35	INTTAB1CC2	TAB1 capture 2/compare 2 match	TAB1	TAB1CCIC2	√	√	√
		36	INTTAB1CC3	TAB1 capture 3/compare 3 match	TAB1	TAB1CCIC3	√	√	√
		37	INTTT0OV	TMT0 overflow	TMT0	TT0OVIC	√	√	√
		38	INTTT0CC0	TMT0 capture 0/compare 0 match	TMT0	TT0CCIC0	√	√	√
		39	INTTT0CC1	TMT0 capture 1/compare 1 match	TMT0	TT0CCIC1	√	√	√
		40	INTTT0EC	TMT0 encoder input	TMT0	TT0ECIC	–	–	√

Table 22-1. Interrupt Source List (2/3)

Type	Classification	Default Priority	Name	Trigger	Generating Unit	Interrupt Control Register	JE3E	JF3E	JG3E
Maskable	Interrupt	41	INTTAA0OV	TAA0 overflow	TAA0	TAA0OVIC	√	√	√
		42	INTTAA0CC0	TAA0 capture 0/compare 0 match	TAA0	TAA0CCIC0	√	√	√
		43	INTTAA0CC1	TAA0 capture 1/compare 1 match	TAA0	TAA0CCIC1	√	√	√
		44	INTTAA1OV	TAA1 overflow	TAA1	TAA1OVIC	√	√	√
		45	INTTAA1CC0	TAA1 capture 0/compare 0 match	TAA1	TAA1CCIC0	√	√	√
		46	INTTAA1CC1	TAA1 capture 1/compare 1 match	TAA1	TAA1CCIC1	√	√	√
		47	INTTAA2OV	TAA2 overflow	TAA2	TAA2OVIC	√	√	√
		48	INTTAA2CC0	TAA2 capture 0/compare 0 match	TAA2	TAA2CCIC0	√	√	√
		49	INTTAA2CC1	TAA2 capture 1/compare 1 match	TAA2	TAA2CCIC1	√	√	√
		50	INTTAA3OV	TAA3 overflow	TAA3	TAA3OVIC	√	√	√
		51	INTTAA3CC0	TAA3 capture 0/compare 0 match	TAA3	TAA3CCIC0	√	√	√
		52	INTTAA3CC1	TAA3 capture 1/compare 1 match	TAA3	TAA3CCIC1	√	√	√
		53	INTTAA4OV	TAA4 overflow	TAA4	TAA4OVIC	√	√	√
		54	INTTAA4CC0	TAA4 capture 0/compare 0 match	TAA4	TAA4CCIC0	√	√	√
		55	INTTAA4CC1	TAA4 capture 1/compare 1 match	TAA4	TAA4CCIC1	√	√	√
		59	INTTM0EQ0	TMM0 compare match	TMM0	TM0EQIC0	√	√	√
		60	INTTM1EQ0	TMM1 compare match	TMM1	TM1EQIC0	√	√	√
		61	INTTM2EQ0	TMM2 compare match	TMM2	TM2EQIC0	√	√	√
		62	INTTM3EQ0	TMM3 compare match	TMM3	TM3EQIC0	√	√	√
		67	INTCF0R /INTUC3R /INTIIC1	CSIF0 transfer completion/UARTC3 reception completion/UARTC3 reception error/IIC1 transfer completion	CSIF0 /UARTC3 /IIC1	CE0RIC /UC3RIC /IIC1C1	√	√	√
		68	INTCF0T /INTUC3T	CSIF0 continuous transfer write enable/ UARTC3 continuous transfer write enable	CSIF0 /UARTC3	CF0TIC /UC3TIC	√	√	√
		69	INTCF1R /INTUC1R /INTIIC0	CSIF1 reception completion/ CSIF1 reception error /UARTC1 reception completion/UARTC1 reception error/IIC0 transfer completion	CSIF1 /UARTC1 /IIC0	CF1RIC /UC1RIC /IIC0C0	-	-	√
		70	INTCF1T /INTUC1T	CSIF1 continuous transfer write enable/ UARTC1 continuous transfer write enable	CSIF1 /UARTC1	CF1TIC /UC1TIC	-	-	√
		71	INTCF2R /INTUC0R	CSIF2 reception completion/CSIF2 reception error/ UARTC0 reception completion/UARTC0 reception error	CSIF2 /UARTC0	CF2RIC /UC0RIC	√	√	√
		72	INTCF2T /INTUC0T	CSIF2 continuous transfer write enable/UARTC0 continuous transfer write enable	CSIF2 /UARTC0	CF2TIC /UC0TIC	√	√	√
		73	INTCF3R	CSIF3 reception completion/CSIF3 reception error	CSIF3	CF3RIC	-	√	√
		74	INTCF3T	CSIF3 continuous transfer write enable	CSIF3	CF3TIC	-	√	√
		78	INTCF4R	CSIF4 reception completion/CSIF4 reception error	CSIF4	CF4RIC	-	√	√
		79	INTCF4T	CSIF4 continuous transfer write enable	CSIF4	CF4TIC	-	√	√
		87	INTUC2R /INTIIC2	UARTC2 reception completion/UARTC2 reception error/IIC2 transfer completion	UARTC2 /IIC2	UC2RIC /IIC2C2	√	√	√
88	INTUC2T	UARTC2 continuous transfer write enable	UARTC2	UC2TIC	√	√	√		
90	INTAD	A/D converter completion	A/D	ADIC	√	√	√		

Table 22-1. Interrupt/Exception Source List (3/3)

Type	Classification	Default Priority	Name	Trigger	Generating Unit	Interrupt Control Register	JE3E	JF3E	JG3E
Maskable	Interrupt	91	INTDMA0	DMA0 transfer completion	DMA	DMAIC0	√	√	√
		92	INTDMA1	DMA1 transfer completion	DMA	DMAIC1	√	√	√
		93	INTDMA2	DMA2 transfer completion	DMA	DMAIC2	√	√	√
		94	INTDMA3	DMA3 transfer completion	DMA	DMAIC3	√	√	√
		95	INTKR	Key return interrupt	KR	KRIC	√	√	√
		96	INTRTC0	RTC fixed-cycle signal	RTC	RTC0IC	√	√	√
		97	INTRTC1	RTC alarm match	RTC	RTC1IC	√	√	√
		98	INTRTC2	RTC interval signal	RTC	RTC2IC	√	√	√
		99	INTUSBF0	USBF interrupt	USBF	UFIC0	√	√	√
		100	INTUSBF1	USBF resume interrupt	USBF	UFIC1	√	√	√
		101	INTEMRX	Packet reception	Ethernet	ETMRXIC	√	√	√
		102	INTEMTX	Packet transmission	Ethernet	ETMTXIC	√	√	√
		103	INTEMRQ	Received packet read request	Ethernet	ETMRQIC	√	√	√
		104	INTEMF5	FIFO status	Ethernet	ETMFSIC	√	√	√
		105	INTEMTS	Transmission status	Ethernet	ETMTSIC	√	√	√
		106	INTEMRS	Reception status	Ethernet	ETMRSIC	√	√	√
		107	INTEMOV	Statistic counter overflow	Ethernet	ETMOVIC	√	√	√
		108	INTEBER	Error interrupt	Ethernet	ETBERIC	√	√	√
		110	INTC0ERR	CAN0 error	CAN0	ERRIC0	√ ^{Note 1}	√ ^{Note 2}	√ ^{Note 3}
		111	INTC0WUP1	CAN0 wakeup	CAN0	WUPIC0	√ ^{Note 1}	√ ^{Note 2}	√ ^{Note 3}
112	INTC0REC	CAN0 reception	CAN0	RECIC0	√ ^{Note 1}	√ ^{Note 2}	√ ^{Note 3}		
113	INTC0TRX	CAN0 transmission	CAN0	TRXIC0	√ ^{Note 1}	√ ^{Note 2}	√ ^{Note 3}		

- Notes 1.** μ PD70F3829 only
2. μ PD70F3833 only
3. μ PD70F3837 only

23. KEY INTERRUPT FUNCTION (V850ES/JF3-E, V850ES/JG3-E)

A key interrupt request signal (INTKR) can be generated by inputting a falling edge to the eight key input pins (KR0 to KR7).

The following figure shows the configuration of key interrupt.

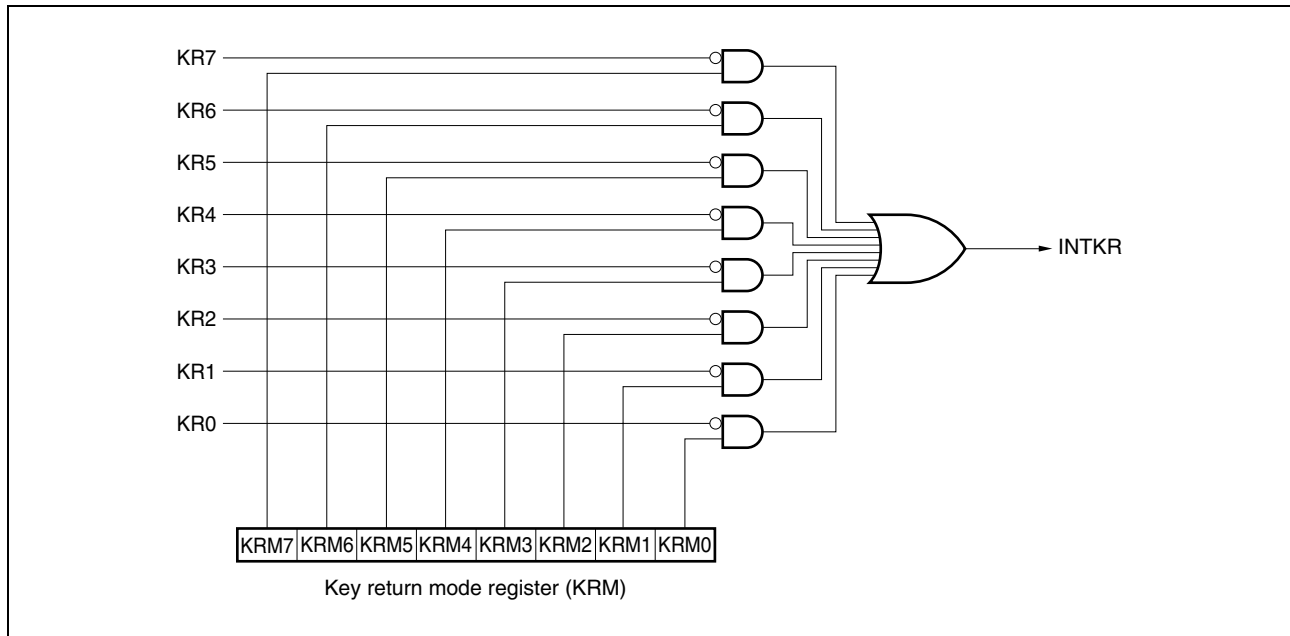

24. STANDBY FUNCTION

The power consumption of the system can be effectively reduced by using the standby modes in combination and selecting the appropriate mode for the application. The available standby modes are listed in Table 24-1.

Table 24-1. Standby Modes

Mode	Function Overview
HALT mode	Mode to stop only the operating clock of the CPU
IDLE1 mode	Mode to stop all the operations of the internal circuit except the oscillator, PLL operation ^{Note} , and flash memory
IDLE2 mode	Mode to stop all the operations of the internal circuit except the oscillator
STOP mode	Mode to stop all the operations of the internal circuit except the subclock oscillator
Subclock operation mode	Mode to operate internal system clock by subclock
Sub-IDLE mode	Mode to stop all the operations of the internal circuit except the oscillator in subclock operation mode

Note PLL retains the previous operation status.

The following figure shows the status transitions of the standby function.

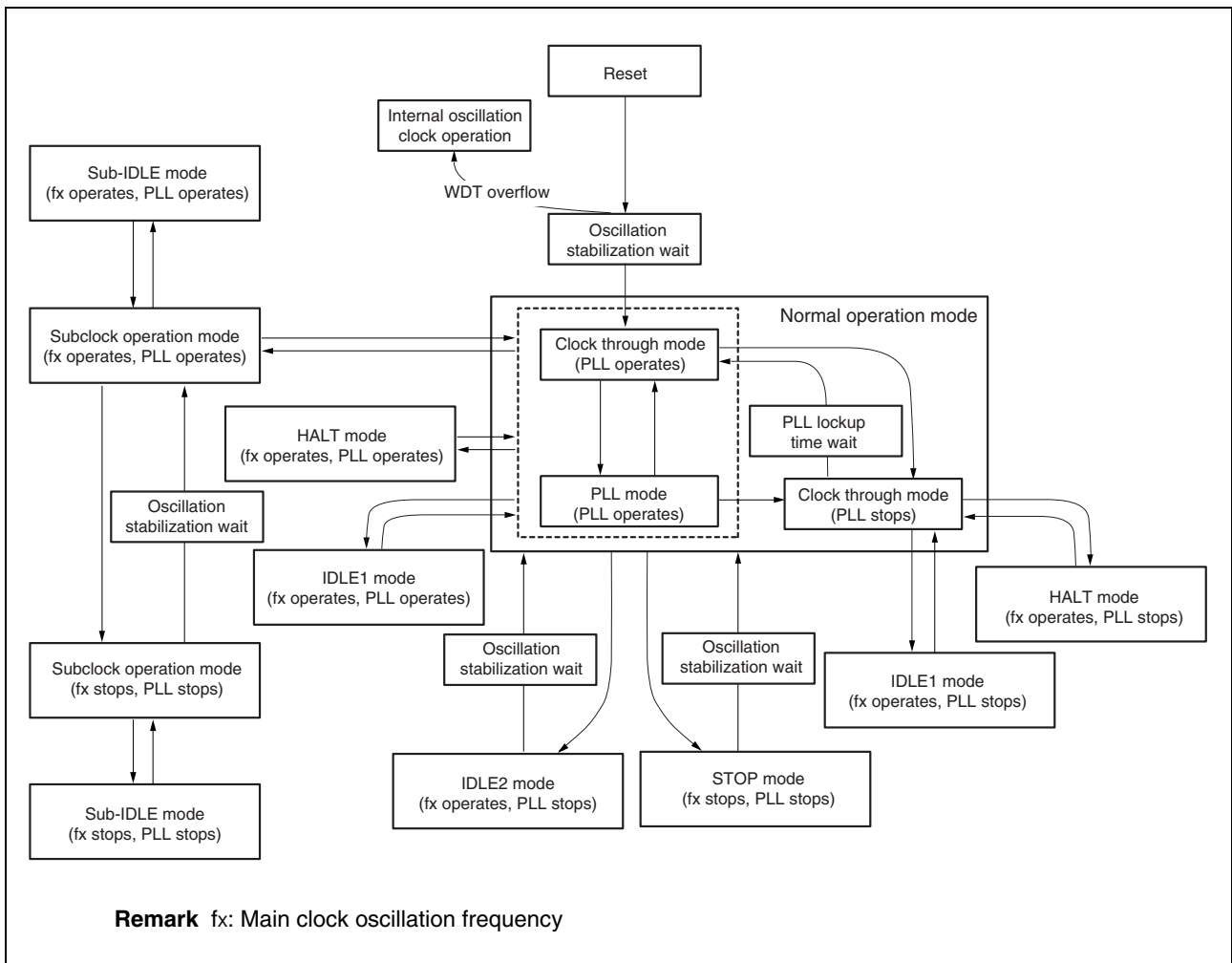

25. RESET FUNCTIONS

The following reset functions are available.

(1) Four types of reset sources

- External reset input via the $\overline{\text{RESET}}$ pin
- Reset via the watchdog timer 2 (WDT2) overflow (WDT2RES)
- System reset by comparing the supply voltage and detection voltage by using the low-voltage detector (LVI)
- System reset by the clock monitor (CLM) upon detection of oscillation stop

After a reset is released, the source of the reset can be confirmed with the reset source flag register (RESF).

(2) Emergency operation mode

If the WDT2 overflows during the main clock oscillation stabilization time inserted after reset, a main clock oscillation anomaly is judged and the CPU starts operating on the internal oscillation clock.

The outline of the reset functions is shown below.

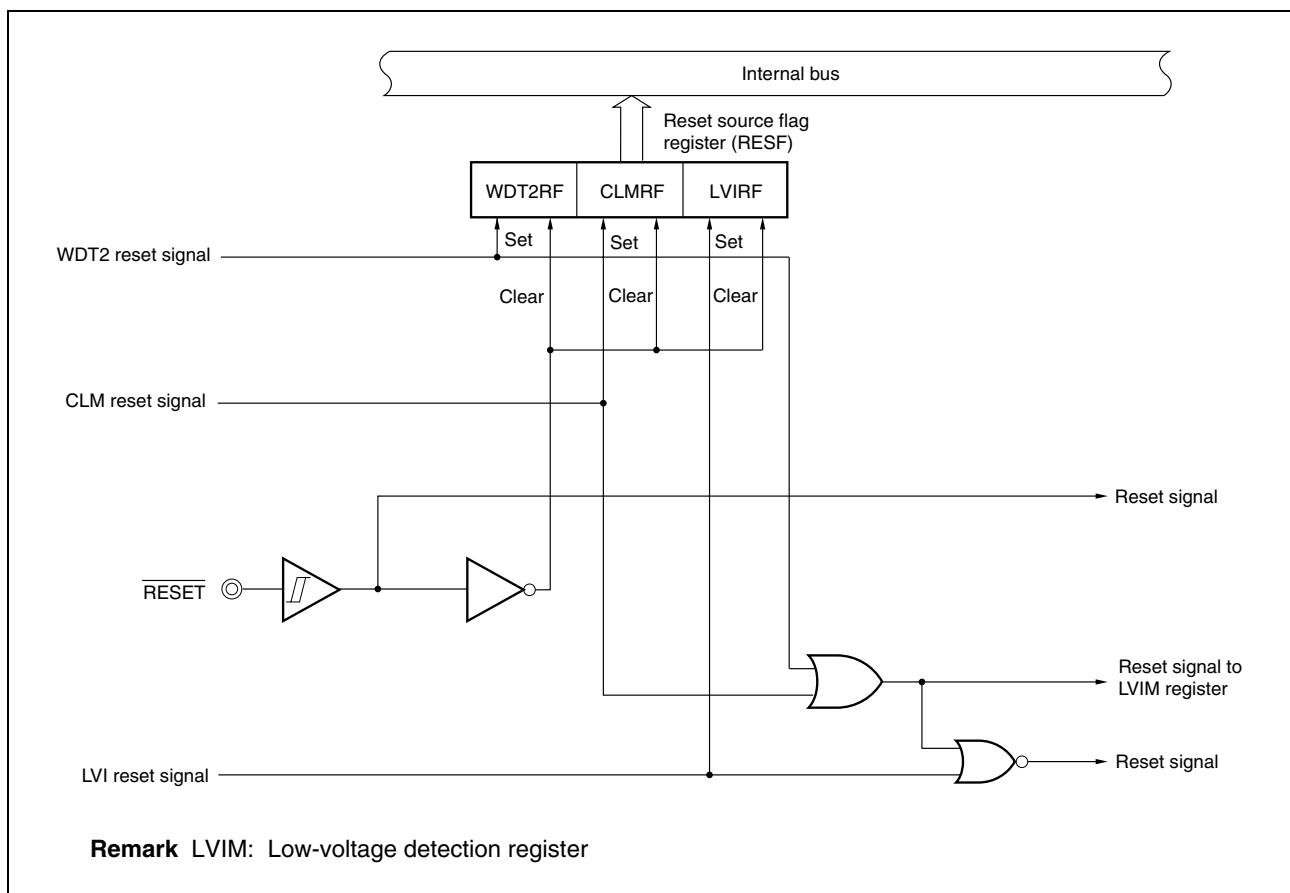

26. CLOCK MONITOR, LOW-VOLTAGE DETECTOR

(1) Clock monitor

The clock monitor samples the main clock by using the internal oscillation clock (f_R) and generates a reset request signal when oscillation of the main clock is stopped.

(2) Low-voltage detector

The low-voltage detector (LVI) has the following functions.

- Compares the supply voltage (V_{DD}) and detection voltage (V_{LVI}) and generates an interrupt request signal or internal reset signal when $V_{DD} < V_{LVI}$.
- An interrupt request signal or internal reset signal can be selected.
- Can operate in STOP mode.
- Operation can be stopped by software.

27. CRC FUNCTIONS

The outline of the CRC function is shown below.

- CRC operation circuit for detection of data block errors
- Generation of 16-bit CRC code using a CRC-CCITT ($X^{16} + X^{12} + X^5 + 1$) generation polynomial for blocks of data of any length in 8-bit units
- CRC code is set to the CRCD data register each time 1-byte data is transferred to the CRCIN register, after the initial value is set to the CRCD register.

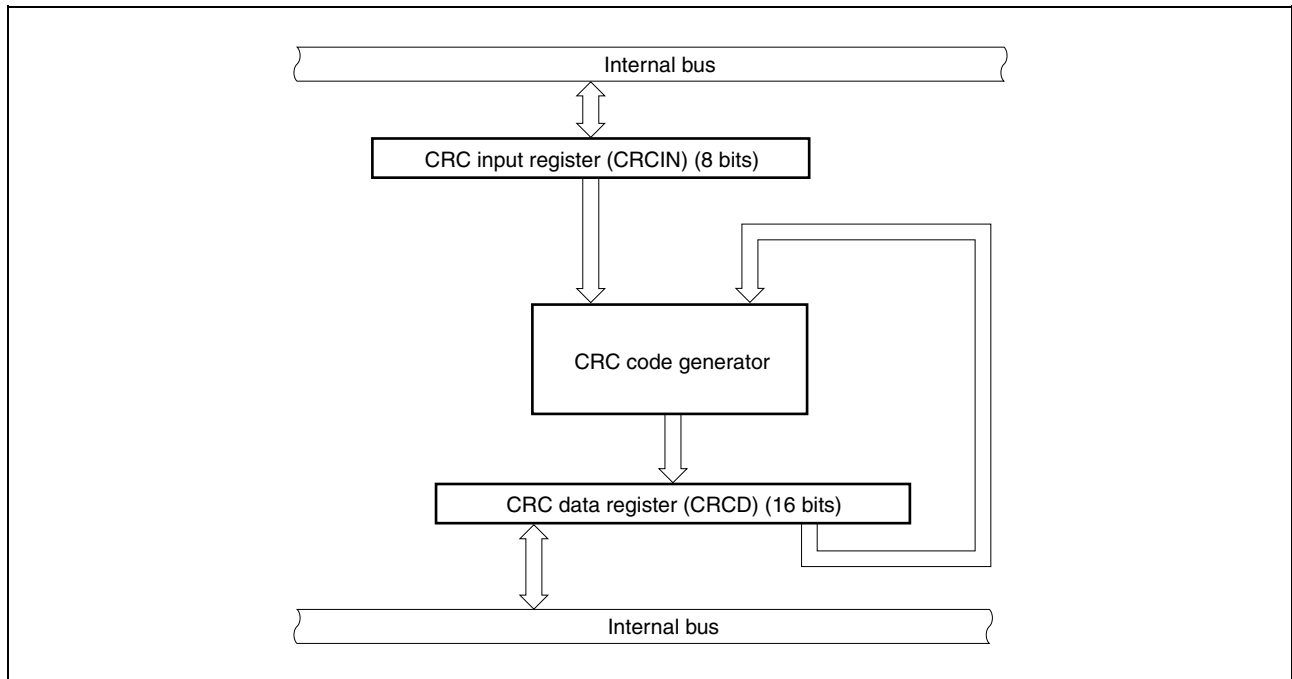

28. REGULATOR FUNCTION

The V850ES/Jx3-E includes a regulator to reduce power consumption and noise.

This regulator supplies a stepped-down V_{DD} power supply voltage to the oscillator block and internal logic circuits except the A/D converter and output buffers). The regulator output voltage is set to 2.5 V (TYP.).

The outline of the regulator functions is shown below.

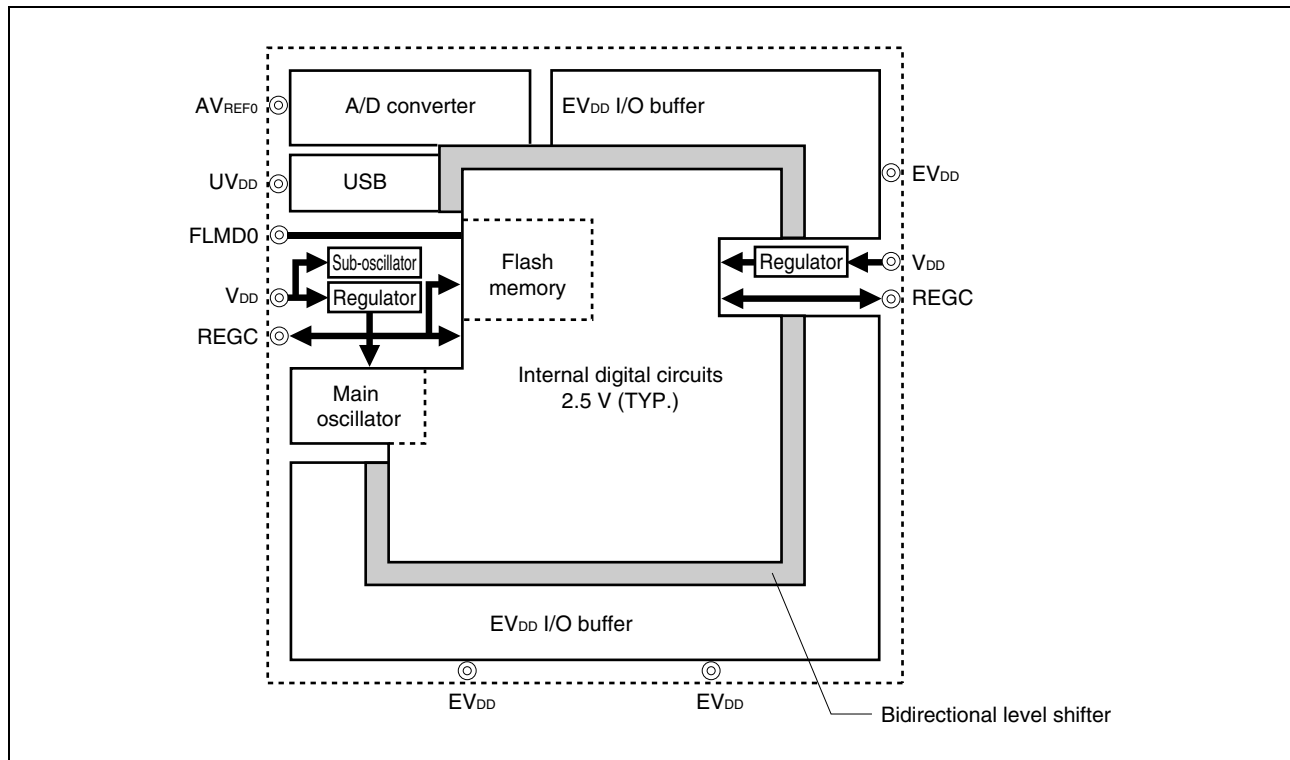

29. FLASH MEMORY

Flash memory versions offer the following advantages for development environments and mass production applications.

- For altering software after the V850ES/Jx3-E is soldered onto the target system.
- For data adjustment when starting mass production.
- For differentiating software according to the specification in small scale production of various models.
- For facilitating inventory management.
- For updating software after shipment.

The flash memory in the V850ES/Jx3-E has the following features.

- 4-byte/1-clock access (when instruction is fetched)
- Memory size: 64/128/256 KB
- Rewrite voltage: Erase/write with a single power supply
- Rewriting method
 - Rewriting by communication with dedicated flash programmer via serial interface (on-board/off-board programming)
 - Rewriting flash memory by user program (self programming)
- Flash memory write prohibit function supported (security function)
- Safe rewriting of entire flash memory area by self programming using boot swap function
- Interrupts can be acknowledged during self programming.

30. ON-CHIP DEBUG FUNCTION

Debugging can be implemented with the V850ES/Jx3-E mounted on the target system.

The NEC Electronics on-chip debug emulators MINICUBE and MINICUBE2 are planned to support the V850ES/Jx3-E.

○ MINICUBE

An on-chip debug function is implemented by using the DCU (debug control unit) in the V850ES/Jx3-E, using the $\overline{\text{DRST}}$, DCK, DMS, DDI, and DDO pins as the debug interface pins.

○ MINICUBE2

An on-chip debug function is implemented by using the user resources (on-chip flash memory, internal RAM, etc.) instead of the DCU, and using the SIF0, SOF0, and $\overline{\text{SCKF0}}$ pins or the SIF3, SOF3, and $\overline{\text{SCKF3}}$ pins or the RXDC0 and TXDC0 pins as the interface pins.

31. PACKAGE DRAWINGS

- V850ES/JE3-E

64-PIN PLASTIC LQFP(FINE PITCH)(10x10)

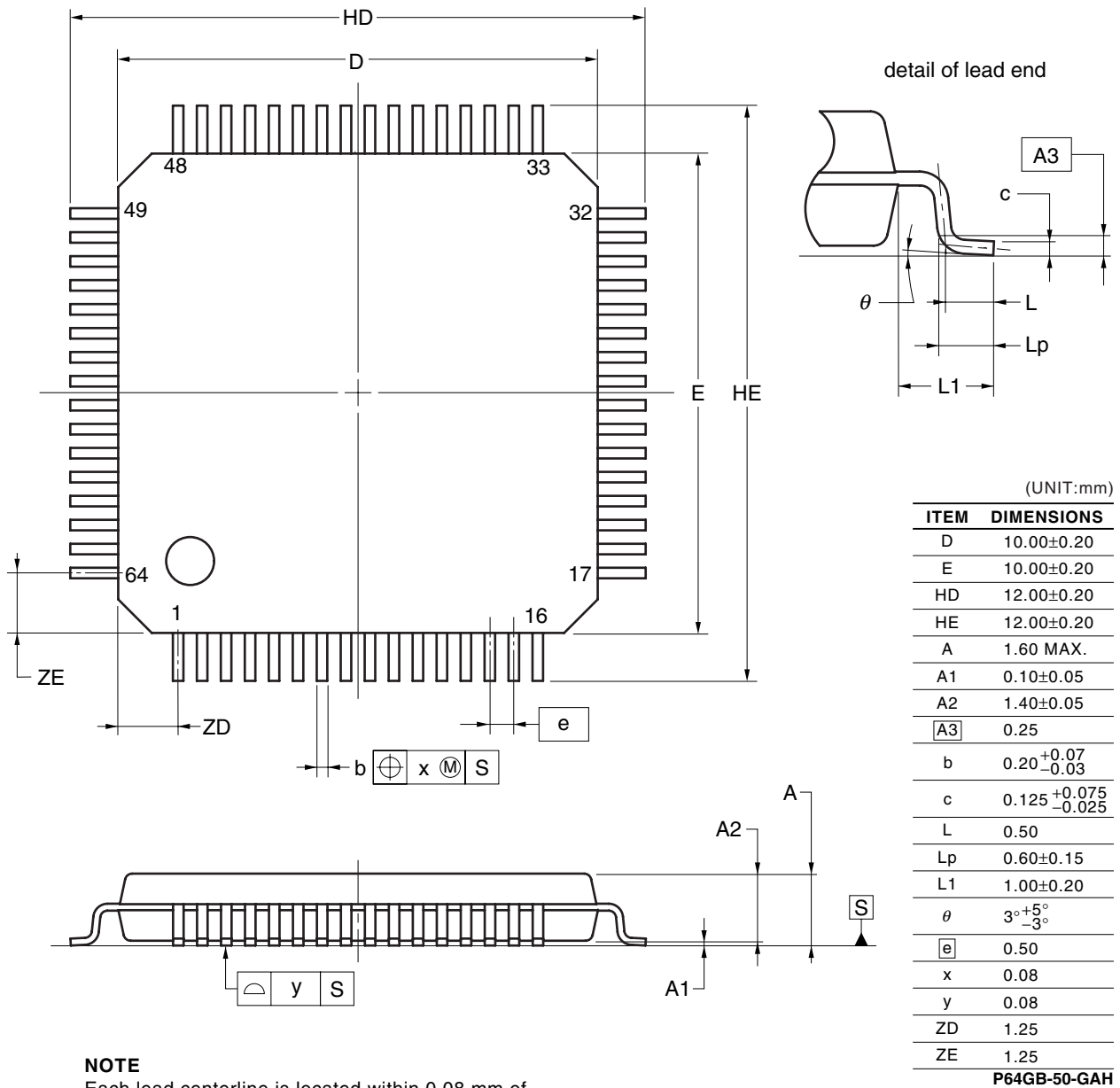

NOTE

Each lead centerline is located within 0.08 mm of its true position at maximum material condition.

Revision History	μ PD70F3826, 70F3827, 70F3828, 70F3829, 70F3830, 70F3831, 70F3832, 70F3833, 70F3834, 70F3835, 70F3836, 70F3837 Data Sheet
-------------------------	--

Rev.	Date	Description	
		Page	Summary
0.01	Sep 30, 2010	–	First Eddition Issued

All documents should contain the following section break and paragraph as the last item. The footers of this document refer to the paragraph in order to reference the last page of the document.

Caution: This product uses SuperFlash[®] technology licensed from Silicon Storage Technology, Inc.

**EEPROM is a trademark of Renesas Electronics Corporation.
 MINICUBE is a registered trademark of Renesas Electronics Corporation in Japan and Germany or a trademark in the United States of America.
 SuperFlash is a registered trademark of Silicon Storage Technology, Inc. in several countries, including the United States and Japan.**

All trademarks and registered trademarks are the property of their respective owners.

NOTES FOR CMOS DEVICES

① VOLTAGE APPLICATION WAVEFORM AT INPUT PIN

Waveform distortion due to input noise or a reflected wave may cause malfunction. If the input of the CMOS device stays in the area between V_{IL} (MAX) and V_{IH} (MIN) due to noise, etc., the device may malfunction. Take care to prevent chattering noise from entering the device when the input level is fixed, and also in the transition period when the input level passes through the area between V_{IL} (MAX) and V_{IH} (MIN).

② HANDLING OF UNUSED INPUT PINS

Unconnected CMOS device inputs can be cause of malfunction. If an input pin is unconnected, it is possible that an internal input level may be generated due to noise, etc., causing malfunction. CMOS devices behave differently than Bipolar or NMOS devices. Input levels of CMOS devices must be fixed high or low by using pull-up or pull-down circuitry. Each unused pin should be connected to V_{DD} or GND via a resistor if there is a possibility that it will be an output pin. All handling related to unused pins must be judged separately for each device and according to related specifications governing the device.

③ PRECAUTION AGAINST ESD

A strong electric field, when exposed to a MOS device, can cause destruction of the gate oxide and ultimately degrade the device operation. Steps must be taken to stop generation of static electricity as much as possible, and quickly dissipate it when it has occurred. Environmental control must be adequate. When it is dry, a humidifier should be used. It is recommended to avoid using insulators that easily build up static electricity. Semiconductor devices must be stored and transported in an anti-static container, static shielding bag or conductive material. All test and measurement tools including work benches and floors should be grounded. The operator should be grounded using a wrist strap. Semiconductor devices must not be touched with bare hands. Similar precautions need to be taken for PW boards with mounted semiconductor devices.

④ STATUS BEFORE INITIALIZATION

Power-on does not necessarily define the initial status of a MOS device. Immediately after the power source is turned ON, devices with reset functions have not yet been initialized. Hence, power-on does not guarantee output pin levels, I/O settings or contents of registers. A device is not initialized until the reset signal is received. A reset operation must be executed immediately after power-on for devices with reset functions.

⑤ POWER ON/OFF SEQUENCE

In the case of a device that uses different power supplies for the internal operation and external interface, as a rule, switch on the external power supply after switching on the internal power supply. When switching the power supply off, as a rule, switch off the external power supply and then the internal power supply. Use of the reverse power on/off sequences may result in the application of an overvoltage to the internal elements of the device, causing malfunction and degradation of internal elements due to the passage of an abnormal current.

The correct power on/off sequence must be judged separately for each device and according to related specifications governing the device.

⑥ INPUT OF SIGNAL DURING POWER OFF STATE

Do not input signals or an I/O pull-up power supply while the device is not powered. The current injection that results from input of such a signal or I/O pull-up power supply may cause malfunction and the abnormal current that passes in the device at this time may cause degradation of internal elements. Input of signals during the power off state must be judged separately for each device and according to related specifications governing the device.

Notice

- All information included in this document is current as of the date this document is issued. Such information, however, is subject to change without any prior notice. Before purchasing or using any Renesas Electronics products listed herein, please confirm the latest product information with a Renesas Electronics sales office. Also, please pay regular and careful attention to additional and different information to be disclosed by Renesas Electronics such as that disclosed through our website.
- Renesas Electronics does not assume any liability for infringement of patents, copyrights, or other intellectual property rights of third parties by or arising from the use of Renesas Electronics products or technical information described in this document. No license, express, implied or otherwise, is granted hereby under any patents, copyrights or other intellectual property rights of Renesas Electronics or others.
- You should not alter, modify, copy, or otherwise misappropriate any Renesas Electronics product, whether in whole or in part.
- Descriptions of circuits, software and other related information in this document are provided only to illustrate the operation of semiconductor products and application examples. You are fully responsible for the incorporation of these circuits, software, and information in the design of your equipment. Renesas Electronics assumes no responsibility for any losses incurred by you or third parties arising from the use of these circuits, software, or information.
- When exporting the products or technology described in this document, you should comply with the applicable export control laws and regulations and follow the procedures required by such laws and regulations. You should not use Renesas Electronics products or the technology described in this document for any purpose relating to military applications or use by the military, including but not limited to the development of weapons of mass destruction. Renesas Electronics products and technology may not be used for or incorporated into any products or systems whose manufacture, use, or sale is prohibited under any applicable domestic or foreign laws or regulations.
- Renesas Electronics has used reasonable care in preparing the information included in this document, but Renesas Electronics does not warrant that such information is error free. Renesas Electronics assumes no liability whatsoever for any damages incurred by you resulting from errors in or omissions from the information included herein.
- Renesas Electronics products are classified according to the following three quality grades: "Standard", "High Quality", and "Specific". The recommended applications for each Renesas Electronics product depends on the product's quality grade, as indicated below. You must check the quality grade of each Renesas Electronics product before using it in a particular application. You may not use any Renesas Electronics product for any application categorized as "Specific" without the prior written consent of Renesas Electronics. Further, you may not use any Renesas Electronics product for any application for which it is not intended without the prior written consent of Renesas Electronics. Renesas Electronics shall not be in any way liable for any damages or losses incurred by you or third parties arising from the use of any Renesas Electronics product for an application categorized as "Specific" or for which the product is not intended where you have failed to obtain the prior written consent of Renesas Electronics. The quality grade of each Renesas Electronics product is "Standard" unless otherwise expressly specified in a Renesas Electronics data sheets or data books, etc.
"Standard": Computers; office equipment; communications equipment; test and measurement equipment; audio and visual equipment; home electronic appliances; machine tools; personal electronic equipment; and industrial robots.
"High Quality": Transportation equipment (automobiles, trains, ships, etc.); traffic control systems; anti-disaster systems; anti-crime systems; safety equipment; and medical equipment not specifically designed for life support.
"Specific": Aircraft; aerospace equipment; submersible repeaters; nuclear reactor control systems; medical equipment or systems for life support (e.g. artificial life support devices or systems), surgical implantations, or healthcare intervention (e.g. excision, etc.), and any other applications or purposes that pose a direct threat to human life.
- You should use the Renesas Electronics products described in this document within the range specified by Renesas Electronics, especially with respect to the maximum rating, operating supply voltage range, movement power voltage range, heat radiation characteristics, installation and other product characteristics. Renesas Electronics shall have no liability for malfunctions or damages arising out of the use of Renesas Electronics products beyond such specified ranges.
- Although Renesas Electronics endeavors to improve the quality and reliability of its products, semiconductor products have specific characteristics such as the occurrence of failure at a certain rate and malfunctions under certain use conditions. Further, Renesas Electronics products are not subject to radiation resistance design. Please be sure to implement safety measures to guard them against the possibility of physical injury, and injury or damage caused by fire in the event of the failure of a Renesas Electronics product, such as safety design for hardware and software including but not limited to redundancy, fire control and malfunction prevention, appropriate treatment for aging degradation or any other appropriate measures. Because the evaluation of microcomputer software alone is very difficult, please evaluate the safety of the final products or system manufactured by you.
- Please contact a Renesas Electronics sales office for details as to environmental matters such as the environmental compatibility of each Renesas Electronics product. Please use Renesas Electronics products in compliance with all applicable laws and regulations that regulate the inclusion or use of controlled substances, including without limitation, the EU RoHS Directive. Renesas Electronics assumes no liability for damages or losses occurring as a result of your noncompliance with applicable laws and regulations.
- This document may not be reproduced or duplicated, in any form, in whole or in part, without prior written consent of Renesas Electronics.
- Please contact a Renesas Electronics sales office if you have any questions regarding the information contained in this document or Renesas Electronics products, or if you have any other inquiries.
(Note 1) "Renesas Electronics" as used in this document means Renesas Electronics Corporation and also includes its majority-owned subsidiaries.
(Note 2) "Renesas Electronics product(s)" means any product developed or manufactured by or for Renesas Electronics.



SALES OFFICES

Renesas Electronics Corporation

<http://www.renesas.com>

Refer to "<http://www.renesas.com/>" for the latest and detailed information.

Renesas Electronics America Inc.
2880 Scott Boulevard Santa Clara, CA 95050-2554, U.S.A.
Tel: +1-408-588-6000, Fax: +1-408-588-6130

Renesas Electronics Canada Limited
1101 Nicholson Road, Newmarket, Ontario L3Y 9C3, Canada
Tel: +1-905-898-5441, Fax: +1-905-898-3220

Renesas Electronics Europe Limited
Dukes Meadow, Millboard Road, Bourne End, Buckinghamshire, SL8 5FH, U.K
Tel: +44-1628-585-100, Fax: +44-1628-585-900

Renesas Electronics Europe GmbH
Arcadiastrasse 10, 40472 Düsseldorf, Germany
Tel: +49-211-6503-0, Fax: +49-211-6503-1327

Renesas Electronics (China) Co., Ltd.
7th Floor, Quantum Plaza, No.27 ZhichunLu Haidian District, Beijing 100083, P.R.China
Tel: +86-10-8235-1155, Fax: +86-10-8235-7679

Renesas Electronics (Shanghai) Co., Ltd.
Unit 204, 205, AZIA Center, No.1233 Lujiazui Ring Rd., Pudong District, Shanghai 200120, China
Tel: +86-21-5877-1818, Fax: +86-21-6887-7858 / -7898

Renesas Electronics Hong Kong Limited
Unit 1601-1613, 16/F., Tower 2, Grand Century Place, 193 Prince Edward Road West, Mongkok, Kowloon, Hong Kong
Tel: +852-2886-9318, Fax: +852-2886-9022/9044

Renesas Electronics Taiwan Co., Ltd.
7F, No. 363 Fu Shing North Road Taipei, Taiwan, R.O.C.
Tel: +886-2-8175-9600, Fax: +886-2-8175-9670

Renesas Electronics Singapore Pte. Ltd.
1 HarbourFront Avenue, #06-10, Keppel Bay Tower, Singapore 098632
Tel: +65-6213-0200, Fax: +65-6278-8001

Renesas Electronics Malaysia Sdn.Bhd.
Unit 906, Block B, Menara Amcorp, Amcorp Trade Centre, No. 18, Jln Persiaran Barat, 46050 Petaling Jaya, Selangor Darul Ehsan, Malaysia
Tel: +60-3-7955-9390, Fax: +60-3-7955-9510

Renesas Electronics Korea Co., Ltd.
11F, Samik Laviel'or Bldg., 720-2 Yeoksam-Dong, Kangnam-Ku, Seoul 135-080, Korea
Tel: +82-2-558-3737, Fax: +82-2-558-5141