

DATE	REV	ECN	APP'D. BY
7-1-08	B0	8479	TRM
9-2-08	B1	8529	TRM

B

B

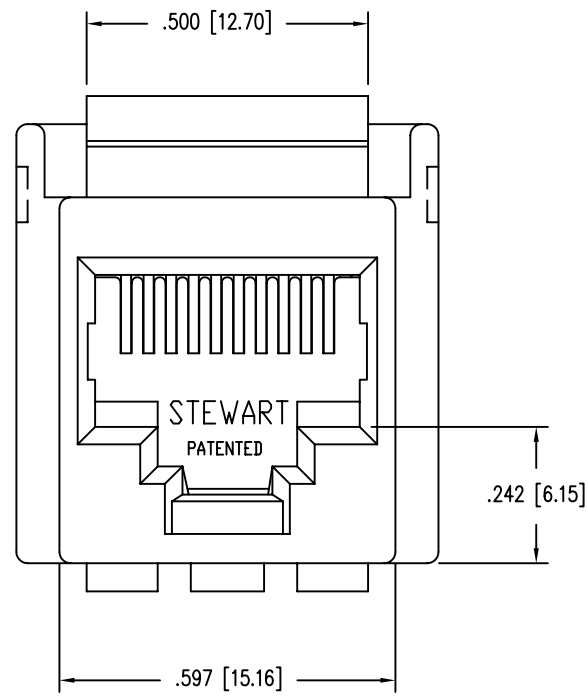
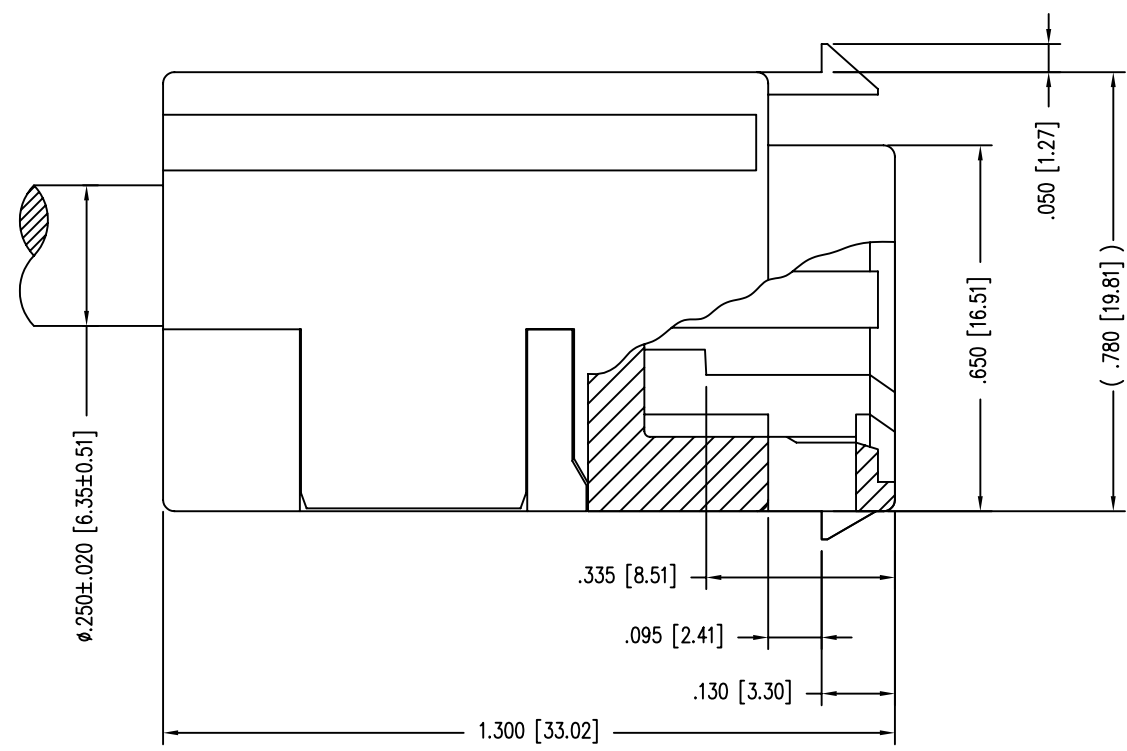
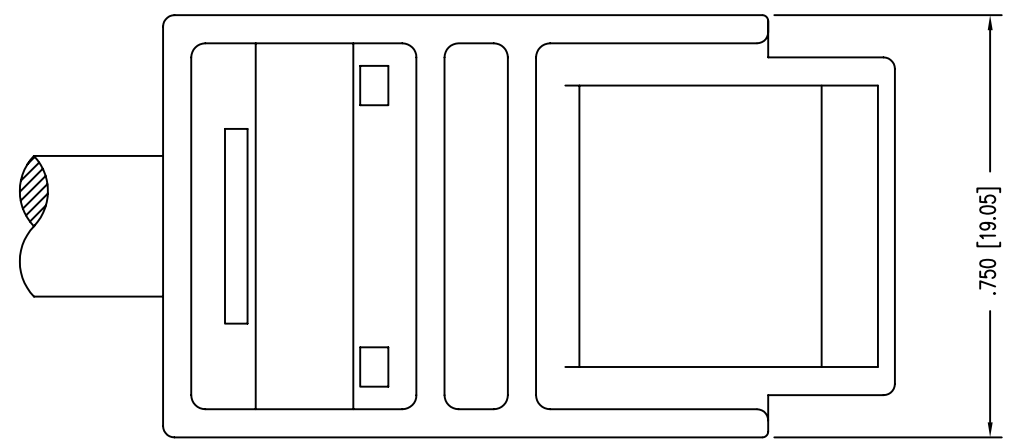

- NOTES:
- CONNECTOR MATERIALS:
HOUSING: PBT
REAR PLASTIC: PBT
STRAIN RELIEF: PBT
LOAD BAR: PC
CONTACTS: COPPER ALLOY
CONTACT PLATING: SELECTIVE GOLD IN CONTACT AREA
SEE CHART FOR PART NUMBER
 - DIMENSIONS AND TOLERANCES COMPLY WITH FCC/CFR 47, PART 68.
 - FOR PRODUCT SPECIFICATION SEE PR026-01

50 MICRO-INCHES [1.27um]	SS-801010SB-SP50-040-250
30 MICRO-INCHES [0.76um]	SS-801010SB-SP30-040-250
CONTACT PLATING IN MATING AREA	PART NUMBER

A

A

REV. 7/3/03

THIRD ANGLE PROJECTION

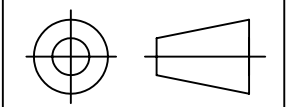

DO NOT SCALE DRAWING
DRAWING IS SUBJECT TO
CHANGE WITHOUT NOTICE

DIMENSIONS: INCHES [METRIC]
UNLESS OTHERWISE SPECIFIED
TOLERANCES ARE $\pm .005 [0.13]$
ANGLES ARE $\pm 1^\circ$

SHEET NO. 1 OF 2

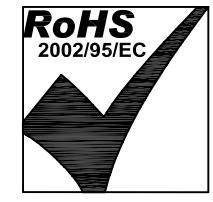

Bel Stewart Connector

11118 Susquehanna Trail South
Glen Rock, PA 17327-9199
(717) 235-7512 Fax: (717) 235-7954 <http://www.stewartconnector.com>

TITLE: 10 CONTACT 10 POSITION SHORT BODY CABLE READY JACK

THIS DRAWING AND THE SUBJECT MATTER SHOWN THEREON ARE CONFIDENTIAL AND THE PROPRIETARY PROPERTY OF BEL STEWART CONNECTOR AND SHALL NOT BE REPRODUCED, COPIED, OR USED IN ANY MANNER WITHOUT PRIOR WRITTEN CONSENT OF BEL STEWART CONNECTOR. THE SUBJECT MATTER MAY BE PATENTED OR A PATENT MAY BE PENDING.

DRN BY:	TRM	DATE	7-3-03
APPD BY:	RGC	DATE	7-3-03
DWG NO.	CT800010	REV.	B1

2

1

AutoCAD

2

1

B

B

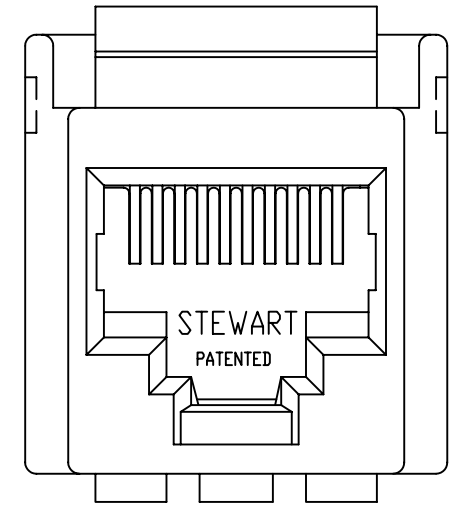
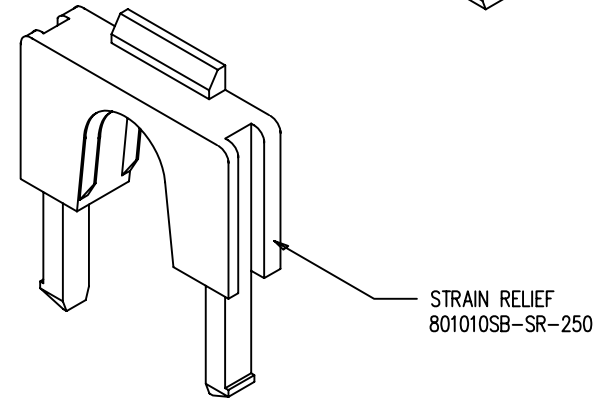
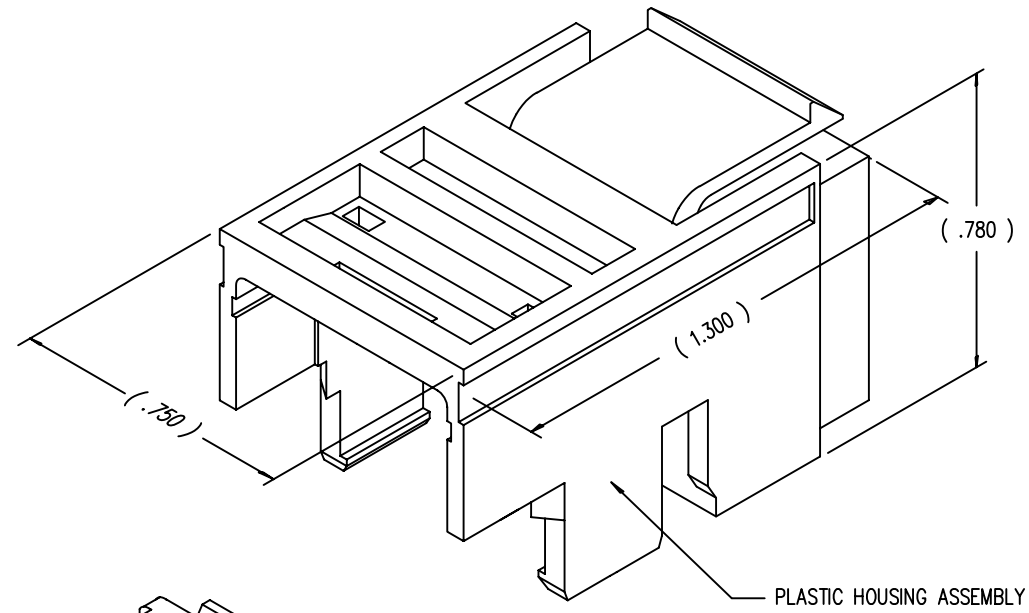

FRONT VIEW OF HOUSING

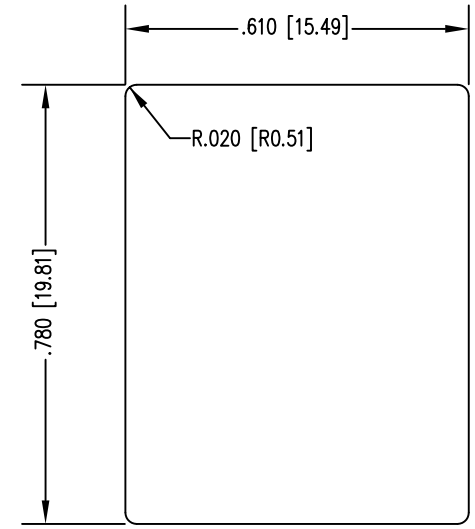

RECOMMENDED PANEL OPENING
(PANEL THICKNESS OF .090 [2.29])

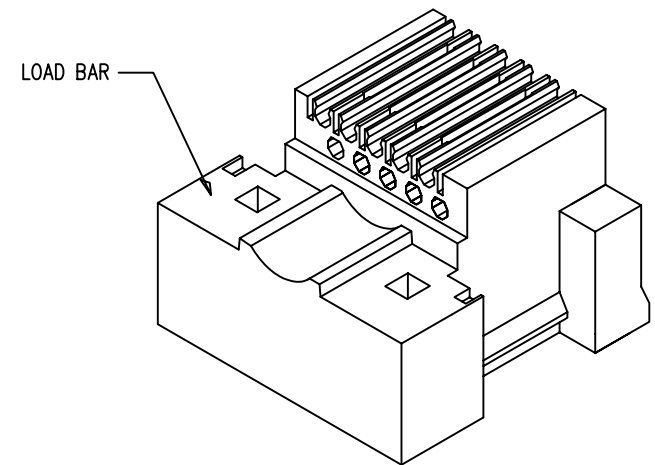

THIRD ANGLE PROJECTION	
DO NOT SCALE DRAWING DRAWING IS SUBJECT TO CHANGE WITHOUT NOTICE	
DIMENSIONS: INCHES [METRIC]	
UNLESS OTHERWISE SPECIFIED TOLERANCES ARE ±.005 [0.13] ANGLES ARE ± 1°	
SHEET NO. 2 OF 2	

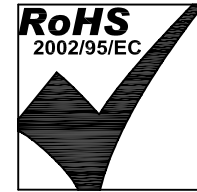

Bel Stewart Connector			
11118 Susquehanna Trail South Glen Rock, PA 17327-9199 (717) 235-7512 Fax: (717) 235-7954 http://www.stewartconnector.com			
TITLE: 10 CONTACT 10 POSITION SHORT BODY CABLE READY JACK			
DRN BY:	TRM	DATE	7-3-03
APPD BY:	RGC	DATE	7-3-03
DWG NO.	CT800010	REV.	B1

A

A

2

1

REV. 7/3/03

AutoCAD