

OL5204N-100-P20**1550+/-20nm 100mW Pulsed MQW Laser Diode DIL Module with SMF.****1. DESCRIPTION**

OL5204N-100-P20 is a 1550nm Laser Diode in DIL package with SMF.

2. FEATURES

- Fiber output : Po=100mW
- Pulsed MQW FP Laser
- 14-pin DIL package module
- Single mode fiber(SMF)
- Built-in TEC

3. APPLICATION

- OTDRs
- Optical Measuring Instruments

4.OPTICAL AND ELECTRICAL CHARACTERISTICS

(TLD= 25°C, 10μs pulse width and 1% duty)

Parameter	Symbol	Test Conditions	Min.	Typ.	Max.	Unit
Threshold Current	I _{th}	---	---	25	60	mA
Operation Current	I _{op}	Po=100mW	---	600	800	mA
LD Forward Voltage	V _f		---	2.0	3.0	V
Center Wavelength	λ _c		1530	1550	1570	nm
Spectral Width	σ	Po=100mW, RMS×1	---	5	10	nm
Cooler Capacity	ΔT	Po=100mW	40	---	---	°C
Cooler Current	I _c	ΔT=40° C,Po=100mW	---	---	1.2	A
Cooler Voltage	V _c		---	2	3	V
Thermistor Resistance	R _{th}	---	9.5	10	10.5	kΩ

5.ABSOLUTE MAXIMUM RATING

(Tc = 25°C, unless otherwise specified)

Parameter	Symbol	Rating	Unit
Fiber Output Power	Po	120*	mW
LD Reverse Voltage	VR(LD)	2.0	V
LD Forward Current	IF(LD)	1000*	mA
Cooler Current	Ic	1.2	A
Operating Temperature	Topr	-20 to +65	°C
Storage Temperature	Tstg	-40 to +70	°C

Pulse width ≤ 10μs , duty ≤ 1%

Exceeding these ratings may lead to immediate destruction or permanent deterioration of the device.

6. CONNECTOR AND FIBER SPECIFICATIONS

Parameter	Specifications	Unit
Type	SMF	---
Mode Field Diameter	10±1	μm
Cladding Diameter	125±2	μm
Jacket Diameter	900	μm
Length	1 (Min.)	m

7.ORDERING INFORMATION

OL 5 204 N – 100 – P 20 – FC

Wavelength Range

5: 1.5μm

Package number

Device Structure

N: FP Laser

Optical Output Power

Laser in mW

Pulsed

Wavelength Tolerance

20: +/-20nm

Connector

FC: FC/Super PC(default),

SC: SC/Super PC. LC:LC/Super PC

8.ATTACHED DATA (at 25°C)

- (1) If-Po graph (2) Spectrum graph at Po=100mW
- (3) Threshold current (Ith) (4) Operating current (Iop) at Po=100mW
- (5) Center wavelength(λc) at Po=100mW (6) Spectral Width(σ) at Po=100mW

9.OUTLINE DRAWING

All dimensions in millimeters
 Tolerances unless noted +/-0.5
 Package Type 204

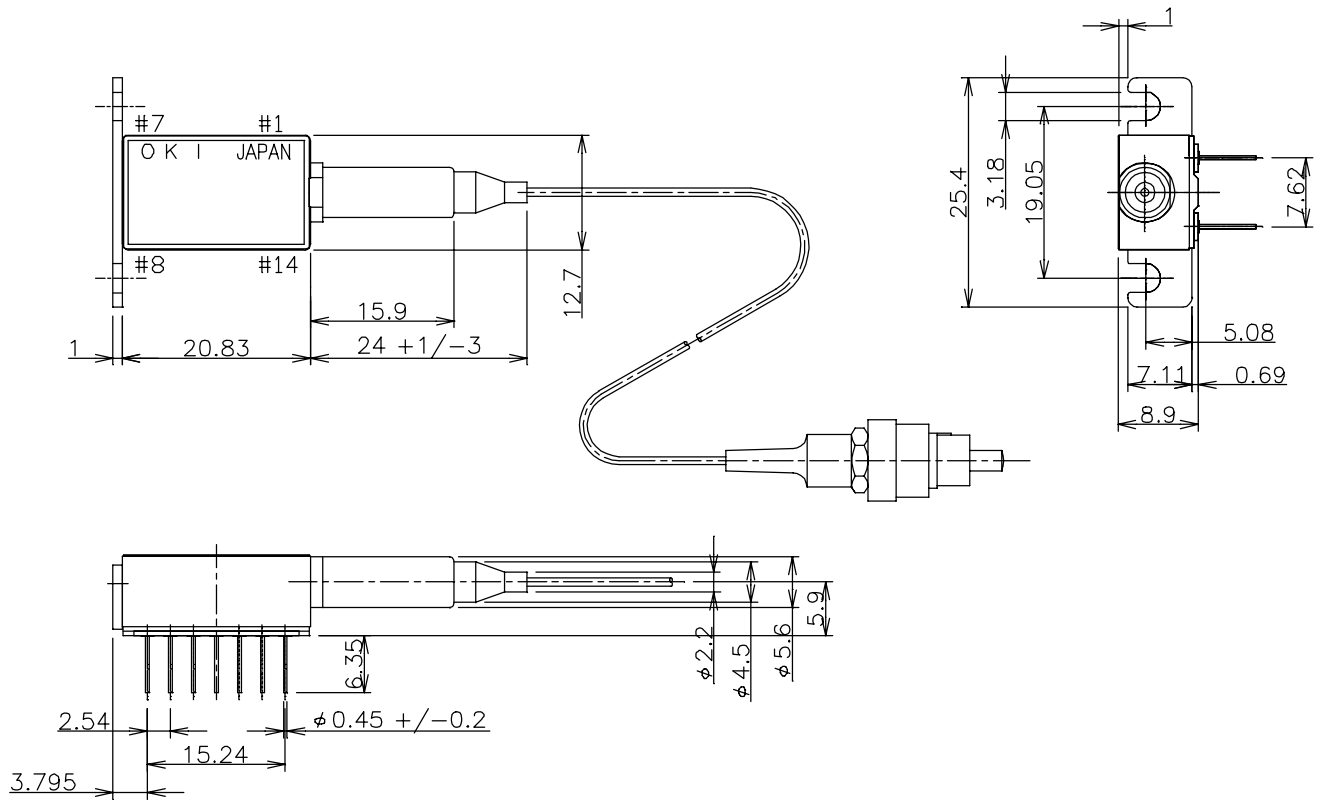

Package Pinout

Pin No.	Function	Pin No.	Function
1	TEC+	8	NC
2	NC	9	LD Cathode
3	NC	10	GND
4	NC	11	Thermistor
5	LD Anode(GND)	12	Thermistor
6	NC	13	NC
7	NC	14	TEC-

10 .Typical characteristics

Test Sample:OL5204N-100-P20

Optical and Electrical Characteristics

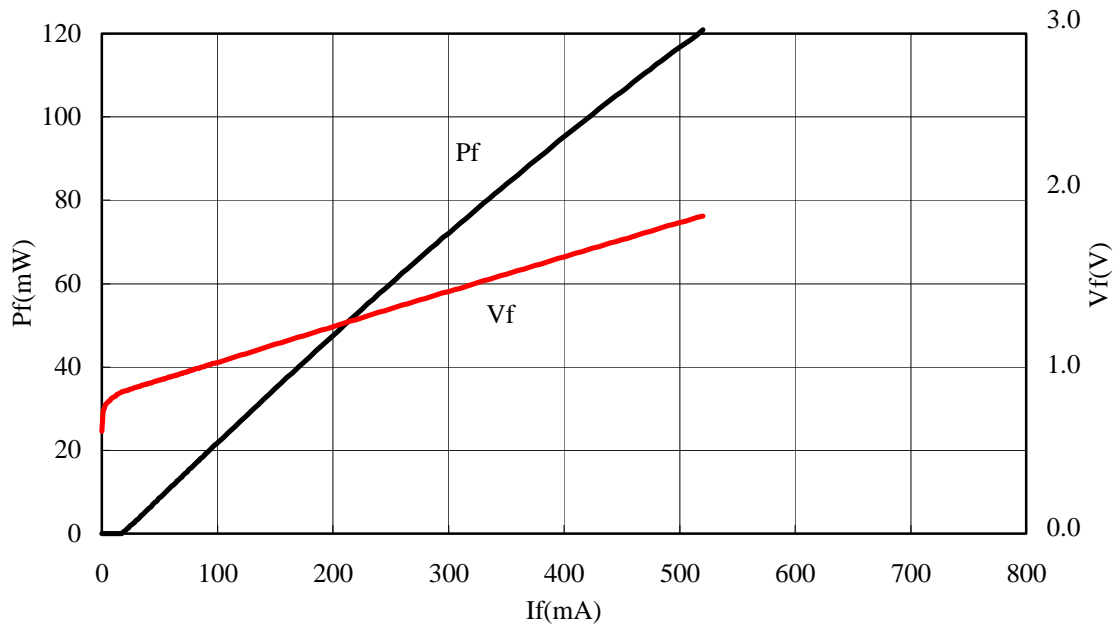

Spectrum Graph

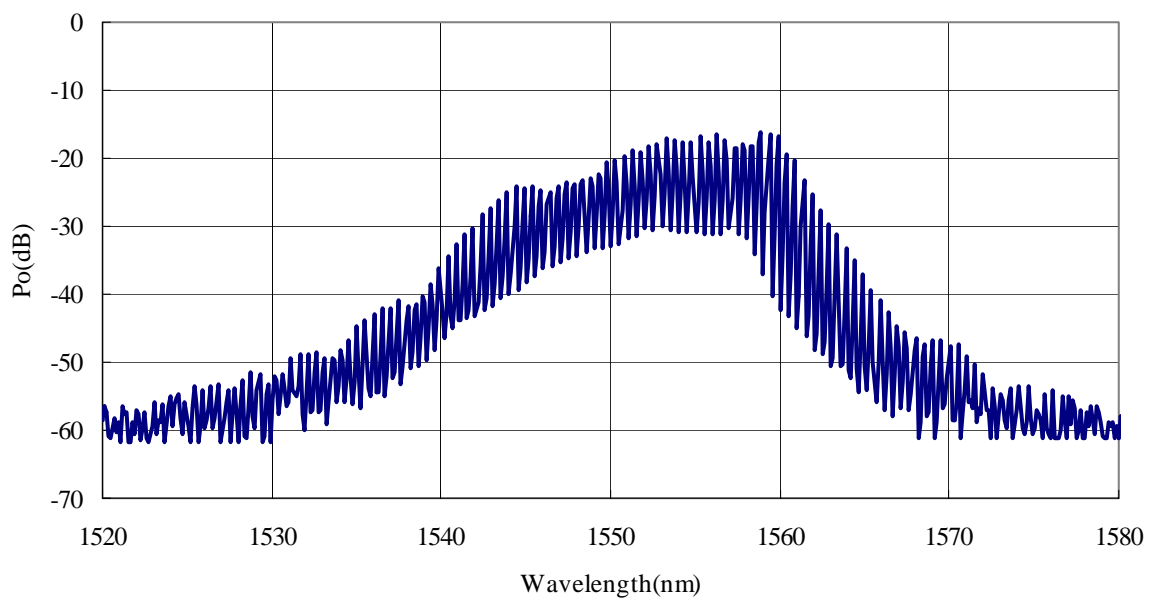

For LD
SAFETY INFORMATION ON THIS PRODUCT



<p>Warning</p> <p>Laser Beam</p>	<p>A laser beam is emitted from this laser diode during operation. The invisible or visible laser beam, directly or indirectly, may cause injury to the eye or loss of eyesight.</p> <p>Do not look directly into the laser beam.</p> <p>Avoid exposure to the laser beam, any reflected or collimated beam.</p>
<p>Caution</p> <p>GaAs Product</p>	<p>The product contains gallium arsenide, GaAs. GaAs vapor and powder are hazardous to human health if inhaled, ingested or swallowed.</p> <p>Do not destroy or burn the product.</p> <p>Do not crush or chemically dissolve the product.</p> <p>Do not put the product in the mouth.</p> <p>Observe related laws and company regulations when discarding this product. The product should be excluded from general industrial waste or household garbage.</p>
<p>Caution</p> <p>Optical Fiber</p>	<p>A glass-fiber is attached on the product. Handle with care.</p> <p>When the fiber is broken or damaged, handle carefully to avoid injury from the damaged part or fragments.</p>

OKI Electronics Components

Notice

1. The information contained herein can change without notice owing to product and/or technical improvements. Before using the product, please make sure that the information being referred to is up-to-date.
2. The outline of action and examples for application circuits described herein have been chosen as an explanation for the standard action and performance of the product. When planning to use the product, please ensure that the external conditions are reflected in the actual circuit, assembly, and program designs.
3. When designing your product, please use our product below the specified maximum ratings and within the specified operating ranges including, but not limited to, operating voltage, power dissipation, and operating temperature.
4. Oki assumes no responsibility or liability whatsoever for any failure or unusual or unexpected operation resulting from misuse, neglect, improper installation, repair, alteration or accident, improper handling, or unusual physical or electrical stress including, but not limited to, exposure to parameters beyond the specified maximum ratings or operation outside the specified operating range.
5. Neither indemnity against nor license of a third party's industrial and intellectual property right, etc. is granted by us in connection with the use of the product and/or the information and drawings contained herein. No responsibility is assumed by us for any infringement of a third party's right which may result from the use thereof.
6. The products listed in this document are intended for use in general electronics equipment for commercial applications (e.g., office automation, communication equipment, measurement equipment, consumer electronics, etc.). These products are not authorized for use in any system or application that requires special or enhanced quality and reliability characteristics nor in any system or application where the failure of such system or application may result in the loss or damage of property, or death or injury to humans. Such applications include, but are not limited to, traffic and automotive equipment, safety devices, aerospace equipment, nuclear power control, medical equipment, and life-support systems.
7. Certain products in this document may need government approval before they can be exported to particular countries. The purchaser assumes the responsibility of determining the legality of export of these products and will take appropriate and necessary steps at their own expense for these.
8. No part of the contents contained herein may be reprinted or reproduced without our prior permission.

Sales Support**JAPAN/ASIA Oki Electric Industry Co., Ltd.**

550-1, Higashiasakawa-cho, Hachioji-shi, Tokyo 193-8550
 Phone: +81-426-62-6646
 INTERNET: <http://www.oki.com>

AMERICA Oki Optical Components

785 North Mary Avenue, Sunnyvale, CA 94086
 Phone: +1-408-737-6379 Fax: +1-408-737-6579
 INTERNET: <http://www.okioptical.com>

EUROPE Oki Electric Europe GmbH

D-41460 Neuss, Germany
 Phone: +49-2131-15960 Fax: +49-2131-103539
 INTERNET: <http://www.oki-europe.de>

Copyright 2004 Oki Electric Industry Co., Ltd