

PLUG, 45° ADAPTER ASSEMBLY

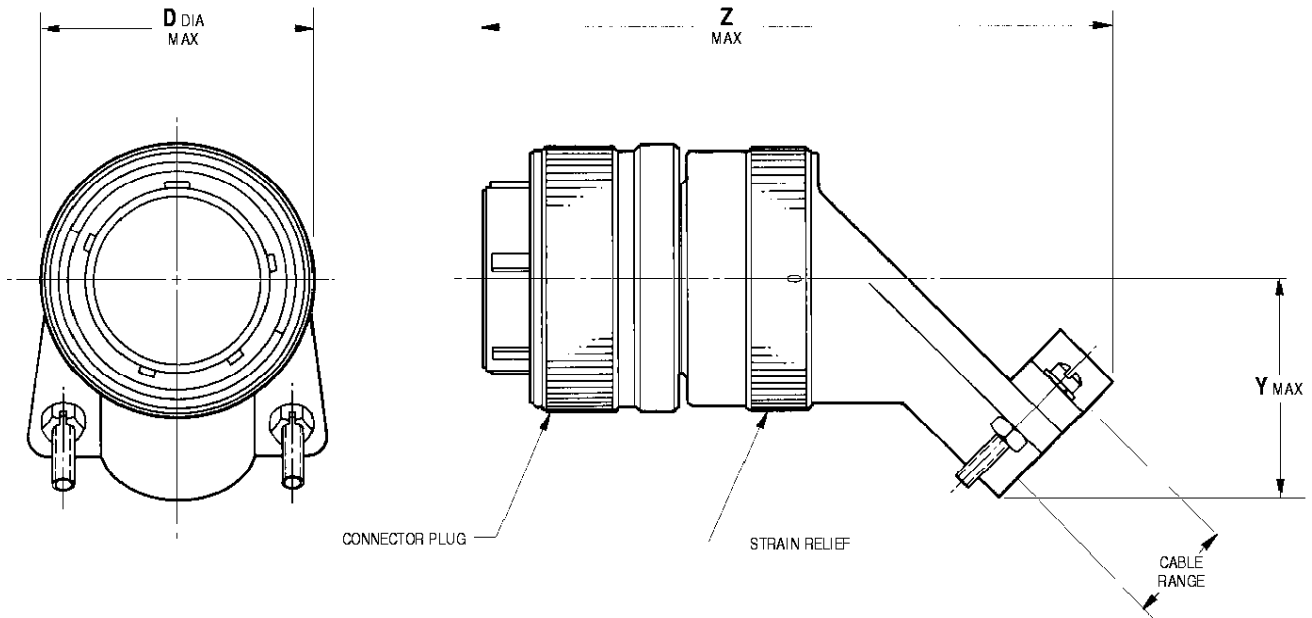

SAMPLE CATALOG NUMBER

To complete catalog number,
see detailed part number breakdown, pages 9 and 10.

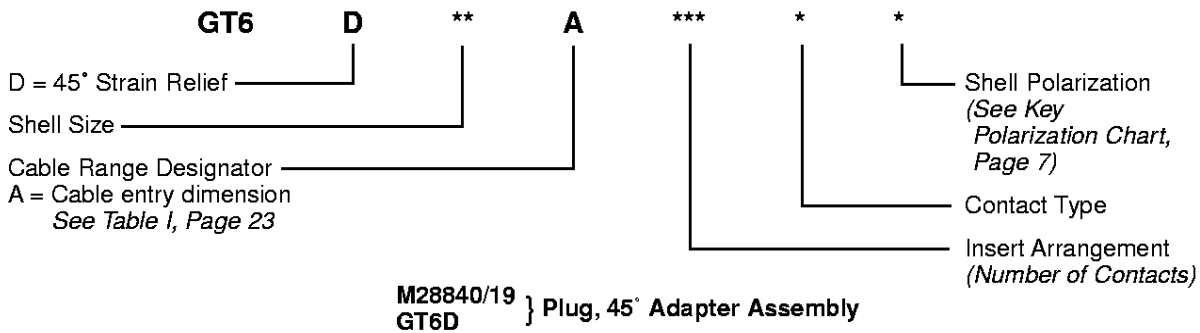

SHELL SIZE	CABLE RANGE DESIGNATOR <i>See Table I, Page 23</i>	D DIA MAX		Y MAX		Z MAX		MAX OD OVER REAR CLAMPS	
		IN	MM	IN	MM	IN	MM	IN	MM
11	A	1.028	26.11	.928	23.57	3.125	79.37	.832	21.13
13	A	1.141	28.98	.928	23.57	3.125	79.37	.832	21.13
15	A	1.263	32.59	.991	25.17	3.250	82.55	.989	25.12
17	A	1.387	35.23	1.110	28.19	3.312	84.12	1.046	26.57
19	A	1.513	38.43	1.172	29.77	3.375	85.72	1.319	33.50
23	A	1.703	43.26	1.235	31.37	3.438	87.32	1.557	39.55
25	A	1.825	46.35	1.297	32.94	3.500	88.90	1.653	41.99
29	A	2.143	54.43	1.543	39.19	3.750	95.25	1.819	46.20
33	A	2.329	59.16	1.668	42.37	3.875	98.42	2.020	51.31