



Section I. Cyclone II Device Family Data Sheet

This section provides information for board layout designers to successfully layout their boards for Cyclone™ II devices. It contains the required PCB layout guidelines, device pin tables, and package specifications.

This section includes the following chapters:

- Chapter 1. Introduction
- Chapter 2. Cyclone II Architecture
- Chapter 3. Configuration & Testing
- Chapter 4. Hot Socketing & Power-On Reset
- Chapter 5. DC Characteristics & Timing Specifications
- Chapter 6. Reference & Ordering Information

Revision History

The table below shows the revision history for Chapters 1 through 6.

Chapter(s)	Date / Version	Changes Made
1	November 2005, v2.1	<ul style="list-style-type: none">● Updated Introduction and Features.● Updated Table 1–3.
	July 2005, v2.0	<ul style="list-style-type: none">● Updated technical content throughout.● Updated Table 1–2.● Added Tables 1–3 and 1–4.
	November 2004, v1.1	<ul style="list-style-type: none">● Updated Table 1–2.● Updated bullet list in the “Features” section.
	June 2004 v1.0	Added document to the Cyclone II Device Handbook.

Chapter(s)	Date / Version	Changes Made
2	November 2005, v2.1	<ul style="list-style-type: none"> • Updated Table 2–8. • Updated Figures 2–11 and 2–12. • Updated Programmable Drive Strength table. • Updated Table 2–17. • Updated Table 2–19. • Updated Table 2–20.
	July 2005, v2.0	<ul style="list-style-type: none"> • Updated technical content throughout. • Updated Table 2–17.
	February 2005 v1.2	Updated figure 2-12.
	November 2004, v1.1	Updated Table 2–20 .
	June 2004, v1.0	Added document to the Cyclone II Device Handbook.
3	July 2005, v2.0	Updated technical content.
	February 2005, v1.2	Updated information on JTAG chain limitations.
	November 2004, v1.1	Updated Table 3–4 .
	June 2004, v1.0	Added document to the Cyclone II Device Handbook.
4	July 2005, v2.0	Updated technical content throughout.
	February 2005 v1.1	Removed ESD section.
	June 2004, v1.0	Added document to the Cyclone II Device Handbook.
5	March 2006, v2.3	<ul style="list-style-type: none"> • Updated Table 5–15 and associated notes.
	December 2005, v2.2	<ul style="list-style-type: none"> • Updated PLL Timing Specifications
	November 2005, v2.1	Updated technical content throughout.
	July 2005, v2.0	Updated technical content throughout.
	November 2004, v1.1	<ul style="list-style-type: none"> • Updated the “Differential I/O Standards” section. • Updated Table 5–51.
	June 2004, v1.0	Added document to the Cyclone II Device Handbook.

Chapter(s)	Date / Version	Changes Made
6	November 2005, v1.2	Updated software introduction.
	November 2004, v1.1	Updated Figure 6–1 .
	June 2004, v1.0	Added document to the Cyclone II Device Handbook.

Introduction

Following the immensely successful first-generation Cyclone™ device family, Altera® Cyclone II FPGAs extend the low-cost FPGA density range to 68,416 logic elements (LEs) and provide up to 622 usable I/O pins and up to 1.1 Mbits of embedded memory. Cyclone II FPGAs are manufactured on 300-mm wafers using TSMC's 90-nm low-k dielectric process to ensure rapid availability and low cost. By minimizing silicon area, Cyclone II devices can support complex digital systems on a single chip at a cost that rivals that of ASICs. Unlike other FPGA vendors who compromise power consumption and performance for low-cost, Altera's latest generation of low-cost FPGAs—Cyclone II FPGAs, offer 60 percent higher performance and half the power consumption of competing 90-nm FPGAs. The low cost and optimized feature set of Cyclone II FPGAs make them ideal solutions for a wide array of automotive, consumer, communications, video processing, test and measurement, and other end-market solutions. Reference designs, system diagrams, and IP, found at www.Altera.com, are available to help you rapidly develop complete end-market solutions using Cyclone II FPGAs.

Low-Cost Embedded Processing Solutions

Cyclone II devices support the Nios II embedded processor which allows you to implement custom-fit embedded processing solutions. Cyclone II devices can also expand the peripheral set, memory, I/O, or performance of embedded processors. Single or multiple Nios II embedded processors can be designed into a Cyclone II device to provide additional co-processing power or even replace existing embedded processors in your system. Using Cyclone II and Nios II together allow for low-cost, high-performance embedded processing solutions which allow you to extend your product's life cycle and improve time to market over standard product solutions.

Low-Cost DSP Solutions

Use Cyclone II FPGAs alone or as DSP co-processors to improve price-to-performance ratios for digital signal processing (DSP) applications. You can implement high-performance yet low-cost DSP systems with the following Cyclone II features and design support:

- Up to 150 18×18 multipliers
- Up to 1.1 Mbit of on-chip embedded memory
- High-speed interfaces to external memory

- DSP intellectual property (IP) cores
- DSP Builder interface to The Mathworks Simulink and Matlab design environment
- DSP Development Kit, Cyclone II Edition

Cyclone II devices include a powerful FPGA feature set optimized for low-cost applications including a wide range of density, memory, embedded multiplier, and packaging options. Cyclone II devices support a wide range of common external memory interfaces and I/O protocols required in low-cost applications. Parameterizable IP cores from Altera and partners make using Cyclone II interfaces and protocols fast and easy.

Features

The Cyclone II device family offers the following features:

- High-density architecture with 4,608 to 68,416 LEs
 - M4K embedded memory blocks
 - Up to 1.1 Mbits of RAM available without reducing available logic
 - 4,096 memory bits per block (4,608 bits per block including 512 parity bits)
 - Variable port configurations of $\times 1$, $\times 2$, $\times 4$, $\times 8$, $\times 9$, $\times 16$, $\times 18$, $\times 32$, and $\times 36$
 - True dual-port (one read and one write, two reads, or two writes) operation for $\times 1$, $\times 2$, $\times 4$, $\times 8$, $\times 9$, $\times 16$, and $\times 18$ modes
 - Byte enables for data input masking during writes
 - Up to 260-MHz operation
- Embedded multipliers
 - Up to 150 18×18 -bit multipliers are each configurable as two independent 9×9 -bit multipliers with up to 250-MHz performance
 - Optional input and output registers
- Advanced I/O support
 - High-speed differential I/O standard support, including LVDS, RSDS, mini-LVDS, LVPECL, differential HSTL, and differential SSTL
 - Single-ended I/O standard support, including 2.5-V and 1.8-V, SSTL class I and II, 1.8-V and 1.5-V HSTL class I and II, 3.3-V PCI and PCI-X 1.0, 3.3-, 2.5-, 1.8-, and 1.5-V LVCMOS, and 3.3-, 2.5-, and 1.8-V LVTTTL
 - Peripheral Component Interconnect Special Interest Group (PCI SIG) *PCI Local Bus Specification, Revision 3.0* compliance for 3.3-V operation at 33 or 66 MHz for 32- or 64-bit interfaces

- PCI Express with an external TI PHY and an Altera PCI Express ×1 Megacore® function
 - 133-MHz PCI-X 1.0 specification compatibility
 - High-speed external memory support, including DDR, DDR2, and SDR SDRAM, and QDR II SRAM supported by drop in Altera IP MegaCore functions for ease of use
 - Three dedicated registers per I/O element (IOE): one input register, one output register, and one output-enable register
 - Programmable bus-hold feature
 - Programmable output drive strength feature
 - Programmable delays from the pin to the IOE or logic array
 - I/O bank grouping for unique VCCIO and/or VREF bank settings
 - MultiVolt™ I/O standard support for 1.5-, 1.8-, 2.5-, and 3.3-interfaces
 - Hot-socketing operation support
 - Tri-state with weak pull-up on I/O pins before and during configuration
 - Programmable open-drain outputs
 - Series on-chip termination support
- Flexible clock management circuitry
 - Hierarchical clock network for up to 402.5-MHz performance
 - Up to four PLLs per device provide clock multiplication and division, phase shifting, programmable duty cycle, and external clock outputs, allowing system-level clock management and skew control
 - Up to 16 global clock lines in the global clock network that drive throughout the entire device
- Device configuration
 - Fast serial configuration allows configuration times less than 100 ms
 - Decompression feature allows for smaller programming file storage and faster configuration times
 - Supports multiple configuration modes: active serial, passive serial, and JTAG-based configuration
 - Supports configuration through low-cost serial configuration devices
 - Device configuration supports multiple voltages (either 3.3, 2.5, or 1.8 V)
- Intellectual property
 - Altera megafunction and Altera MegaCore function support, and Altera Megafunctions Partners Program (AMPSM) megafunction support, for a wide range of embedded processors, on-chip and off-chip interfaces, peripheral

functions, DSP functions, and communications functions and protocols. Visit the Altera IP MegaStore at www.Altera.com to download IP MegaCore functions.

- Nios II Embedded Processor support

Table 1–1 lists the Cyclone II device family features. Table 1–2 lists the Cyclone II device package offerings and maximum user I/O pins.

Table 1–1. Cyclone II FPGA Family Features						
Feature	EP2C5	EP2C8	EP2C20	EP2C35	EP2C50	EP2C70
LEs	4,608	8,256	18,752	33,216	50,528	68,416
M4K RAM blocks (4 Kbits plus 512 parity bits)	26	36	52	105	129	250
Total RAM bits	119,808	165,888	239,616	483,840	594,432	1,152,000
Embedded multipliers (1)	13	18	26	35	86	150
PLLs	2	2	4	4	4	4
Maximum user I/O pins	158	182	315	475	450	622

Note to Table 1–1:

- (1) This is the total number of 18×18 multipliers. For the total number of 9×9 multipliers per device, multiply the total number of 18×18 multipliers by 2.
-

Table 1–2. Cyclone II Package Options & Maximum User I/O Pins *Note (1)*

Device	144-Pin TQFP (2)	208-Pin PQFP (3)	240-Pin PQFP	256-Pin FineLine BGA	484-Pin FineLine BGA	484-Pin Ultra FineLine BGA	672-Pin FineLine BGA	896-Pin FineLine BGA
EP2C5 (6)	89	142		158 (5)				
EP2C8 (6)	85	138		182				
EP2C20 (6)			142	152	315			
EP2C35 (6)					322	322	475	
EP2C50 (6)					294	294	450	
EP2C70 (6)							422	622

Notes to Table 1–2:

- (1) Cyclone II devices support vertical migration within the same package (for example, you can migrate between the EP2C20 device in the 484-pin FineLine BGA® package and the EP2C35 and EP2C50 devices in the same package).
- (2) TQFP: thin quad flat pack.
- (3) PQFP: plastic quad flat pack.
- (4) This package offering is preliminary.
- (5) Vertical migration is supported between the EP2C5F256 and the EP2C8F256 devices. However, not all of the DQ and DQS groups are supported. Vertical migration between the EP2C5 and the EP2C20 in the F256 package is not supported.
- (6) The I/O pin counts for the EP2C5 and EP2C8 devices include 8 dedicated clock pins that can be used for data inputs. The I/O counts for the EP2C20, EP2C35, EP2C50, and EP2C70 devices include 16 dedicated clock pins that can be used for data inputs.

Cyclone II devices support vertical migration within the same package (for example, you can migrate between the EP2C35, EP2C50, and EP2C70 devices in the 672-pin FineLine BGA package). The exception to vertical migration support within the Cyclone II family is noted in [Table 1–3](#).

Vertical migration means that you can migrate to devices whose dedicated pins, configuration pins, and power pins are the same for a given package across device densities.

Table 1–3. Total Number of Non-Migratable I/O Pins for Cyclone II Vertical Migration Paths

Vertical Migration Path	144-Pin TQFP	208-Pin PQFP	256-Pin FineLine BGA (1)	484-Pin FineLine BGA (2)	484-Pin Ultra FineLine BGA	672-Pin FineLine BGA (3)
EP2C5 to EP2C8	4	4	1 (4)			
EP2C8 to EP2C20			30			
EP2C20 to EP2C35				16		
EP2C35 to EP2C50				28	(5)	28
EP2C50 to EP2C70					28	28

Notes to Table 1–3:

- (1) Vertical migration between the EP2C5F256 and the EP2C20F256 devices is not supported.
- (2) When migrating from the EP2C20F484 device to the EP2C50F484 device, a total of 39 I/O pins are non-migratable.
- (3) When migrating from the EP2C35F672 device to the EP2C70F672 device, a total of 56 I/O pins are non-migratable.
- (4) In addition to the one non-migratable I/O pin, there are 34 DQ pins that are non-migratable.
- (5) This package offering is preliminary. This information will be available in a future version of the *Cyclone II Device Handbook*.



When moving from one density to a larger density, I/O pins are often lost because of the greater number of power and ground pins required to support the additional logic within the larger device. For I/O pin migration across densities, you must cross reference the available I/O pins using the device pin-outs for all planned densities of a given package type to identify which I/O pins are migratable.

To ensure that your board layout supports migratable densities within one package offering, enable the applicable vertical migration path within the Quartus® II software (go to Assignments menu, then Device, then click the **Migration Devices** button). After compilation, check the information messages for a full list of I/O, DQ, LVDS, and other pins that are not available because of the selected migration path. Table 1–3 lists the Cyclone II device package offerings and shows the total number of non-migratable I/O pins when migrating from one density device to a larger density device.

Cyclone II devices are available in up to three speed grades: -6, -7, and -8, with -6 being the fastest. Table 1–4 shows the Cyclone II device speed-grade offerings.

Table 1–4. Cyclone II Device Speed Grades

Device	144-Pin TQFP	208-Pin PQFP	240-Pin PQFP	256-Pin FineLine BGA	484-Pin FineLine BGA	484-Pin Ultra FineLine BGA	672-Pin FineLine BGA	896-Pin FineLine BGA
EP2C5	-6, -7, -8	-7, -8		-6, -7, -8				
EP2C8	-6, -7, -8	-7, -8		-6, -7, -8				
EP2C20			-8	-6, -7, -8	-6, -7, -8			
EP2C35					-6, -7, -8	-6, -7, -8	-6, -7, -8	
EP2C50					-6, -7, -8	-6, -7, -8	-6, -7, -8	
EP2C70							-6, -7, -8	-6, -7, -8

Functional Description

Cyclone™ II devices contain a two-dimensional row- and column-based architecture to implement custom logic. Column and row interconnects of varying speeds provide signal interconnects between logic array blocks (LABs), embedded memory blocks, and embedded multipliers.

The logic array consists of LABs, with 16 logic elements (LEs) in each LAB. An LE is a small unit of logic providing efficient implementation of user logic functions. LABs are grouped into rows and columns across the device. Cyclone II devices range in density from 4,608 to 68,416 LEs.

Cyclone II devices provide a global clock network and up to four phase-locked loops (PLLs). The global clock network consists of up to 16 global clock lines that drive throughout the entire device. The global clock network can provide clocks for all resources within the device, such as input/output elements (IOEs), LEs, embedded multipliers, and embedded memory blocks. The global clock lines can also be used for other high fan-out signals. Cyclone II PLLs provide general-purpose clocking with clock synthesis and phase shifting as well as external outputs for high-speed differential I/O support.

M4K memory blocks are true dual-port memory blocks with 4K bits of memory plus parity (4,608 bits). These blocks provide dedicated true dual-port, simple dual-port, or single-port memory up to 36-bits wide at up to 260 MHz. These blocks are arranged in columns across the device in between certain LABs. Cyclone II devices offer between 119 to 1,152 Kbits of embedded memory.

Each embedded multiplier block can implement up to either two 9×9 -bit multipliers, or one 18×18 -bit multiplier with up to 250-MHz performance. Embedded multipliers are arranged in columns across the device.

Each Cyclone II device I/O pin is fed by an IOE located at the ends of LAB rows and columns around the periphery of the device. I/O pins support various single-ended and differential I/O standards, such as the 66- and 33-MHz, 64- and 32-bit PCI standard, PCI-X, and the LVDS I/O standard at a maximum data rate of 805 megabits per second (Mbps) for inputs and 640 Mbps for outputs. Each IOE contains a bidirectional I/O buffer and three registers for registering input, output, and output-enable signals. Dual-purpose DQS, DQ, and DM pins along with delay chains (used to

phase-align double data rate (DDR) signals) provide interface support for external memory devices such as DDR, DDR2, and single data rate (SDR) SDRAM, and QDR II SRAM devices at up to 167 MHz.

Figure 2–1 shows a diagram of the Cyclone II EP2C20 device.

Figure 2–1. Cyclone II EP2C20 Device Block Diagram

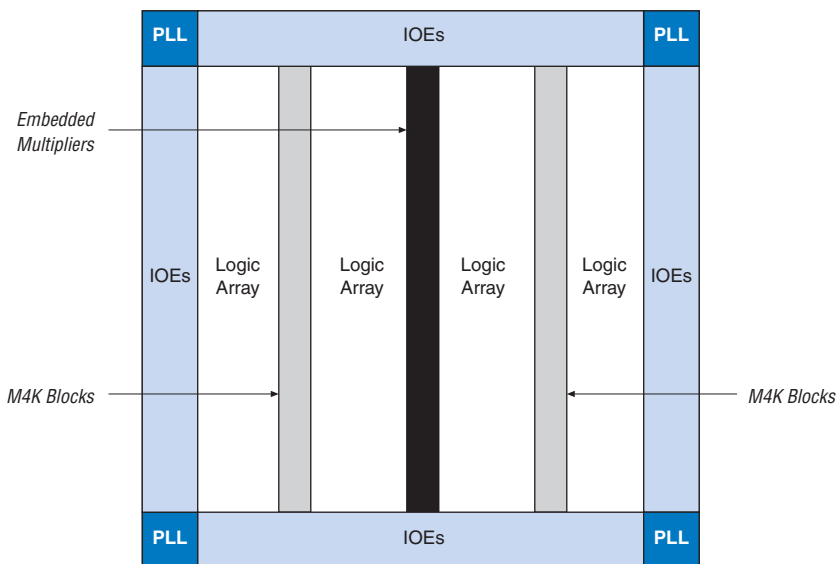

The number of M4K memory blocks, embedded multiplier blocks, PLLs, rows, and columns vary per device. Table 2–1 lists the resources available in each Cyclone II device.

Table 2–1. Cyclone II Device Resources

Device	LAB Columns	LAB Rows	LEs	PLLs	M4K Memory Blocks	Embedded Multiplier Blocks
EP2C5	24	13	4,608	2	26	13
EP2C8	30	18	8,256	2	36	18
EP2C20	46	26	18,752	4	52	26
EP2C35	60	35	33,216	4	105	35
EP2C50	74	43	50,528	4	129	86
EP2C70	86	50	68,416	4	250	150

Logic Elements

The smallest unit of logic in the Cyclone II architecture, the LE, is compact and provides advanced features with efficient logic utilization. Each LE features:

- A four-input look-up table (LUT), which is a function generator that can implement any function of four variables
- A programmable register
- A carry chain connection
- A register chain connection
- The ability to drive all types of interconnects: local, row, column, register chain, and direct link interconnects
- Support for register packing
- Support for register feedback

Figure 2-2 shows a Cyclone II LE.

Figure 2-2. Cyclone II LE

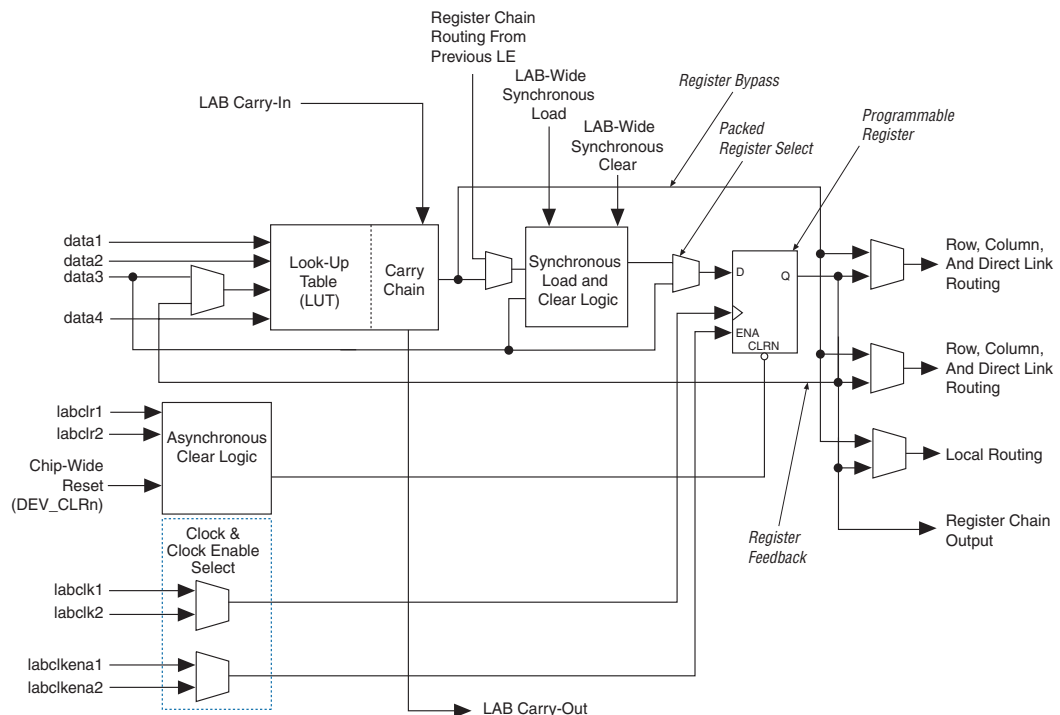

Each LE's programmable register can be configured for D, T, JK, or SR operation. Each register has data, clock, clock enable, and clear inputs. Signals that use the global clock network, general-purpose I/O pins, or any internal logic can drive the register's clock and clear control signals. Either general-purpose I/O pins or internal logic can drive the clock enable. For combinational functions, the LUT output bypasses the register and drives directly to the LE outputs.

Each LE has three outputs that drive the local, row, and column routing resources. The LUT or register output can drive these three outputs independently. Two LE outputs drive column or row and direct link routing connections and one drives local interconnect resources, allowing the LUT to drive one output while the register drives another output. This feature, register packing, improves device utilization because the device can use the register and the LUT for unrelated functions. When using register packing, the LAB-wide synchronous load control signal is not available. See [“LAB Control Signals” on page 2–8](#) for more information.

Another special packing mode allows the register output to feed back into the LUT of the same LE so that the register is packed with its own fan-out LUT, providing another mechanism for improved fitting. The LE can also drive out registered and unregistered versions of the LUT output.

In addition to the three general routing outputs, the LEs within an LAB have register chain outputs. Register chain outputs allow registers within the same LAB to cascade together. The register chain output allows an LAB to use LUTs for a single combinational function and the registers to be used for an unrelated shift register implementation. These resources speed up connections between LABs while saving local interconnect resources. See [“MultiTrack Interconnect” on page 2–10](#) for more information on register chain connections.

LE Operating Modes

The Cyclone II LE operates in one of the following modes:

- Normal mode
- Arithmetic mode

Each mode uses LE resources differently. In each mode, six available inputs to the LE—the four data inputs from the LAB local interconnect, the LAB carry-in from the previous carry-chain LAB, and the register chain connection—are directed to different destinations to implement the desired logic function. LAB-wide signals provide clock, asynchronous clear, synchronous clear, synchronous load, and clock enable control for the register. These LAB-wide signals are available in all LE modes.

The Quartus® II software, in conjunction with parameterized functions such as library of parameterized modules (LPM) functions, automatically chooses the appropriate mode for common functions such as counters, adders, subtractors, and arithmetic functions. If required, you can also create special-purpose functions that specify which LE operating mode to use for optimal performance.

Normal Mode

The normal mode is suitable for general logic applications and combinational functions. In normal mode, four data inputs from the LAB local interconnect are inputs to a four-input LUT (see Figure 2-3). The Quartus II Compiler automatically selects the carry-in or the data3 signal as one of the inputs to the LUT. LEs in normal mode support packed registers and register feedback.

Figure 2-3. LE in Normal Mode

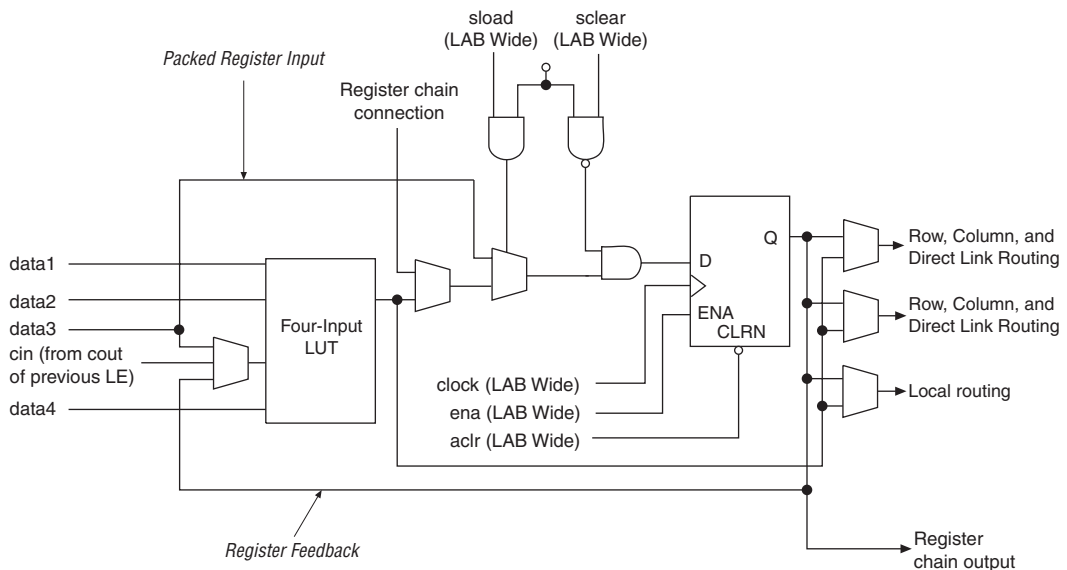

Arithmetic Mode

The arithmetic mode is ideal for implementing adders, counters, accumulators, and comparators. An LE in arithmetic mode implements a 2-bit full adder and basic carry chain (see Figure 2–4). LEs in arithmetic mode can drive out registered and unregistered versions of the LUT output. Register feedback and register packing are supported when LEs are used in arithmetic mode.

Figure 2–4. LE in Arithmetic Mode

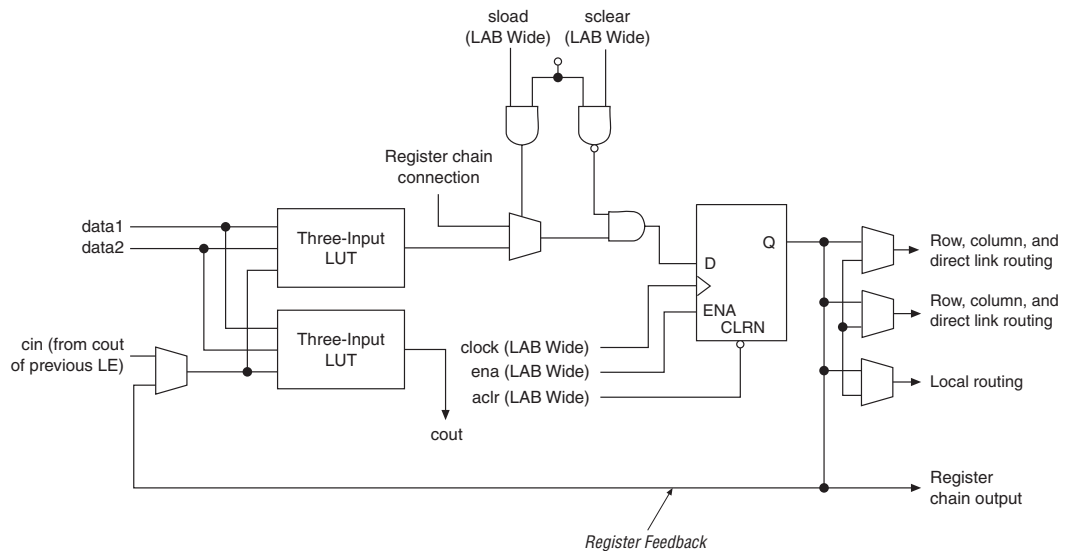

The Quartus II Compiler automatically creates carry chain logic during design processing, or you can create it manually during design entry. Parameterized functions such as LPM functions automatically take advantage of carry chains for the appropriate functions.

The Quartus II Compiler creates carry chains longer than 16 LEs by automatically linking LABs in the same column. For enhanced fitting, a long carry chain runs vertically, which allows fast horizontal connections to M4K memory blocks or embedded multipliers through direct link interconnects. For example, if a design has a long carry chain in a LAB column next to a column of M4K memory blocks, any LE output can feed an adjacent M4K memory block through the direct link interconnect. Whereas if the carry chains ran horizontally, any LAB not next to the column of M4K memory blocks would use other row or column interconnects to drive a M4K memory block. A carry chain continues as far as a full column.

Logic Array Blocks

Each LAB consists of the following:

- 16 LEs
- LAB control signals
- LE carry chains
- Register chains
- Local interconnect

The local interconnect transfers signals between LEs in the same LAB. Register chain connections transfer the output of one LE's register to the adjacent LE's register within an LAB. The Quartus II Compiler places associated logic within an LAB or adjacent LABs, allowing the use of local, and register chain connections for performance and area efficiency. Figure 2-5 shows the Cyclone II LAB.

Figure 2-5. Cyclone II LAB Structure

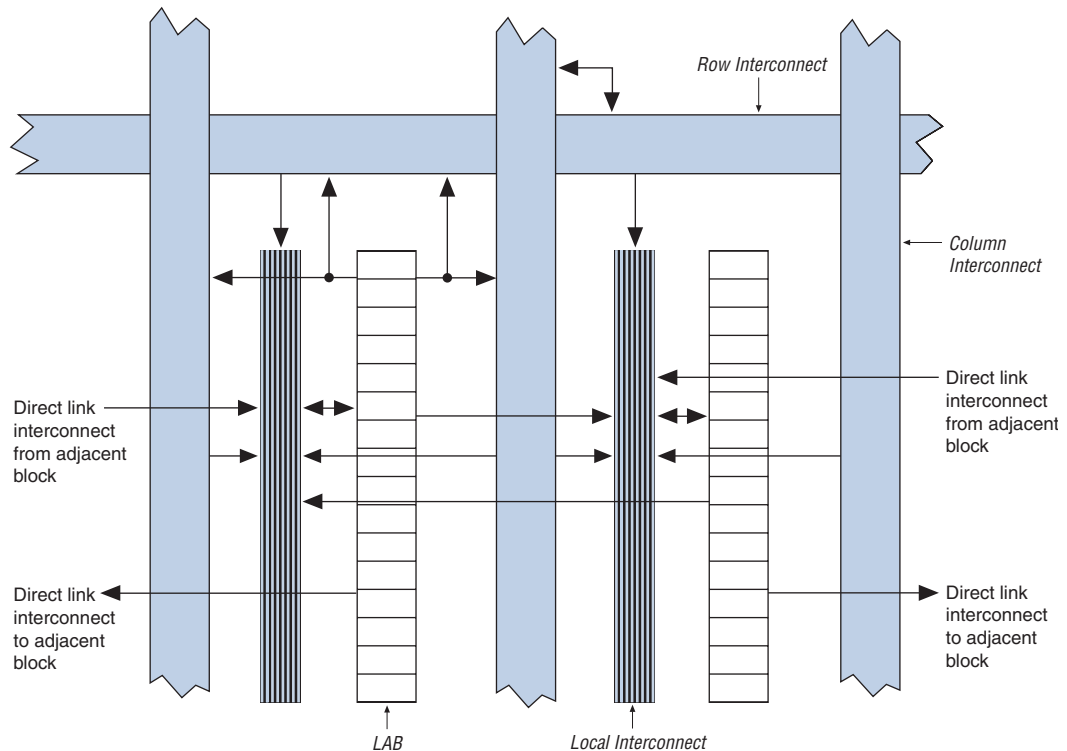

LAB Interconnects

The LAB local interconnect can drive LEs within the same LAB. The LAB local interconnect is driven by column and row interconnects and LE outputs within the same LAB. Neighboring LABs, PLLs, M4K RAM blocks, and embedded multipliers from the left and right can also drive an LAB's local interconnect through the direct link connection. The direct link connection feature minimizes the use of row and column interconnects, providing higher performance and flexibility. Each LE can drive 48 LEs through fast local and direct link interconnects. Figure 2-6 shows the direct link connection.

Figure 2-6. Direct Link Connection

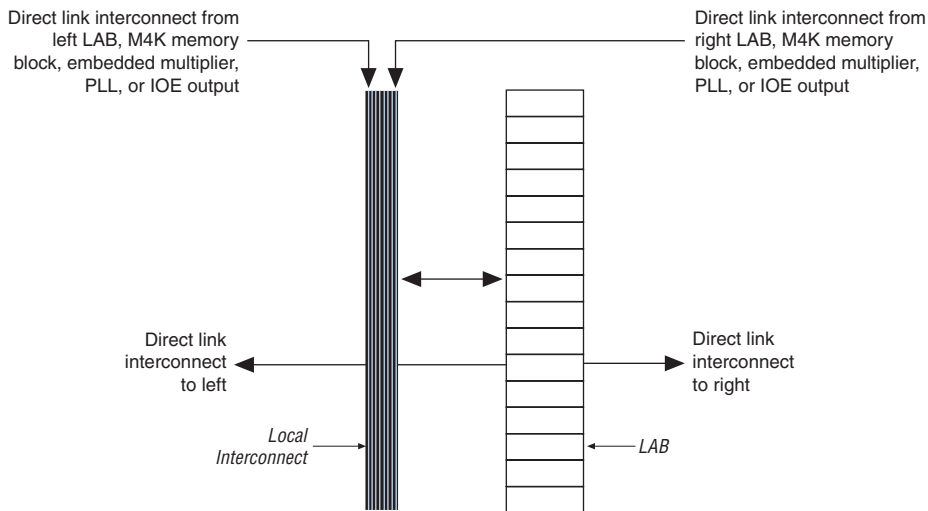

LAB Control Signals

Each LAB contains dedicated logic for driving control signals to its LEs. The control signals include:

- Two clocks
- Two clock enables
- Two asynchronous clears
- One synchronous clear
- One synchronous load

This gives a maximum of seven control signals at a time. When using the LAB-wide synchronous load, the `clkena` of `labclk1` is not available. Additionally, register packing and synchronous load cannot be used simultaneously.

Each LAB can have up to four non-global control signals. Additional LAB control signals can be used as long as they are global signals.

Synchronous clear and load signals are useful for implementing counters and other functions. The synchronous clear and synchronous load signals are LAB-wide signals that affect all registers in the LAB.

Each LAB can use two clocks and two clock enable signals. Each LAB's clock and clock enable signals are linked. For example, any LE in a particular LAB using the `labclk1` signal also uses `labclkena1`. If the LAB uses both the rising and falling edges of a clock, it also uses both LAB-wide clock signals. De-asserting the clock enable signal turns off the LAB-wide clock.

The LAB row clocks [5..0] and LAB local interconnect generate the LAB-wide control signals. The MultiTrack™ interconnect's inherent low skew allows clock and control signal distribution in addition to data. [Figure 2-7](#) shows the LAB control signal generation circuit.

Figure 2-7. LAB-Wide Control Signals

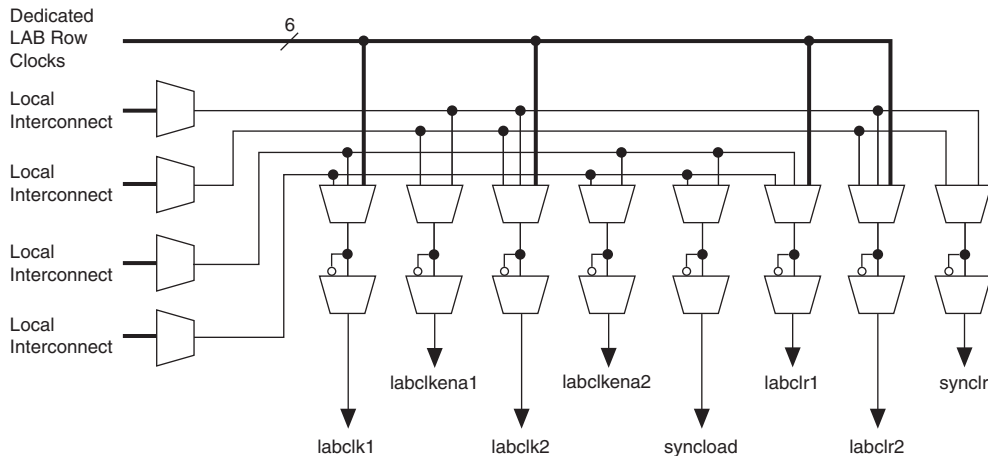

LAB-wide signals control the logic for the register's clear signal. The LE directly supports an asynchronous clear function. Each LAB supports up to two asynchronous clear signals (`labclr1` and `labclr2`).

A LAB-wide asynchronous load signal to control the logic for the register's preset signal is not available. The register preset is achieved by using a NOT gate push-back technique. Cyclone II devices can only support either a preset or asynchronous clear signal.

In addition to the clear port, Cyclone II devices provide a chip-wide reset pin (`DEV_CLRn`) that resets all registers in the device. An option set before compilation in the Quartus II software controls this pin. This chip-wide reset overrides all other control signals.

MultiTrack Interconnect

In the Cyclone II architecture, connections between LEs, M4K memory blocks, embedded multipliers, and device I/O pins are provided by the MultiTrack interconnect structure with DirectDrive™ technology. The MultiTrack interconnect consists of continuous, performance-optimized routing lines of different speeds used for inter- and intra-design block connectivity. The Quartus II Compiler automatically places critical paths on faster interconnects to improve design performance.

DirectDrive technology is a deterministic routing technology that ensures identical routing resource usage for any function regardless of placement within the device. The MultiTrack interconnect and DirectDrive technology simplify the integration stage of block-based designing by eliminating the re-optimization cycles that typically follow design changes and additions.

The MultiTrack interconnect consists of row (direct link, R4, and R24) and column (register chain, C4, and C16) interconnects that span fixed distances. A routing structure with fixed-length resources for all devices allows predictable and repeatable performance when migrating through different device densities.

Row Interconnects

Dedicated row interconnects route signals to and from LABs, PLLs, M4K memory blocks, and embedded multipliers within the same row. These row resources include:

- Direct link interconnects between LABs and adjacent blocks
- R4 interconnects traversing four blocks to the right or left
- R24 interconnects for high-speed access across the length of the device

The direct link interconnect allows an LAB, M4K memory block, or embedded multiplier block to drive into the local interconnect of its left and right neighbors. Only one side of a PLL block interfaces with direct link and row interconnects. The direct link interconnect provides fast communication between adjacent LABs and/or blocks without using row interconnect resources.

The R4 interconnects span four LABs, three LABs and one M4K memory block, or three LABs and one embedded multiplier to the right or left of a source LAB. These resources are used for fast row connections in a four-LAB region. Every LAB has its own set of R4 interconnects to drive either left or right. [Figure 2–8](#) shows R4 interconnect connections from an LAB. R4 interconnects can drive and be driven by LABs, M4K memory blocks, embedded multipliers, PLLs, and row IOEs. For LAB interfacing, a primary LAB or LAB neighbor (see [Figure 2–8](#)) can drive a given R4 interconnect. For R4 interconnects that drive to the right, the primary LAB and right neighbor can drive on to the interconnect. For R4 interconnects that drive to the left, the primary LAB and its left neighbor can drive on to the interconnect. R4 interconnects can drive other R4 interconnects to extend the range of LABs they can drive. Additionally, R4 interconnects can drive R24 interconnects, C4, and C16 interconnects for connections from one row to another.

Figure 2–8. R4 Interconnect Connections

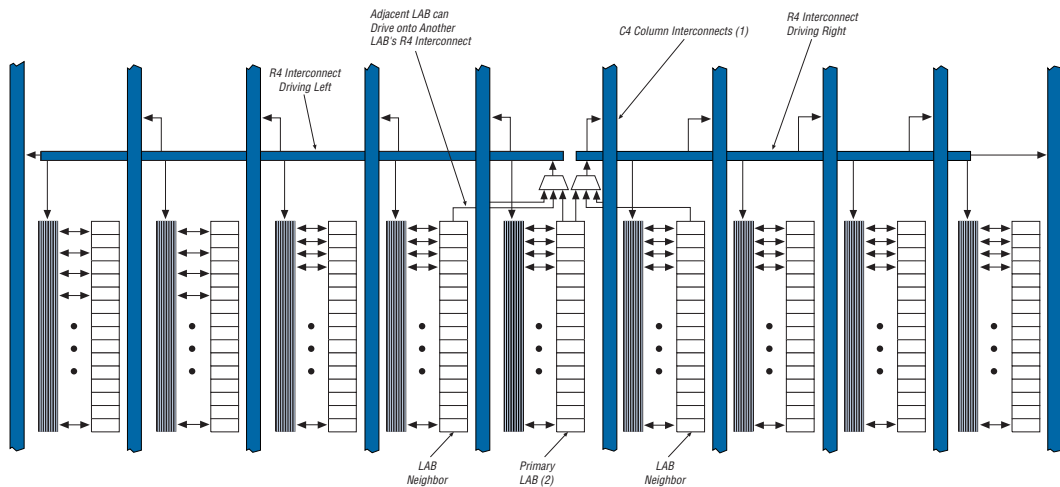

Notes to [Figure 2–8](#):

- (1) C4 interconnects can drive R4 interconnects.
- (2) This pattern is repeated for every LAB in the LAB row.

R24 row interconnects span 24 LABs and provide the fastest resource for long row connections between non-adjacent LABs, M4K memory blocks, dedicated multipliers, and row IOEs. R24 row interconnects drive to other row or column interconnects at every fourth LAB. R24 row interconnects drive LAB local interconnects via R4 and C4 interconnects and do not drive directly to LAB local interconnects. R24 interconnects can drive R24, R4, C16, and C4 interconnects.

Column Interconnects

The column interconnect operates similar to the row interconnect. Each column of LABs is served by a dedicated column interconnect, which vertically routes signals to and from LABs, M4K memory blocks, embedded multipliers, and row and column IOEs. These column resources include:

- Register chain interconnects within an LAB
- C4 interconnects traversing a distance of four blocks in an up and down direction
- C16 interconnects for high-speed vertical routing through the device

Cyclone II devices include an enhanced interconnect structure within LABs for routing LE output to LE input connections faster using register chain connections. The register chain connection allows the register output of one LE to connect directly to the register input of the next LE in the LAB for fast shift registers. The Quartus II Compiler automatically takes advantage of these resources to improve utilization and performance. [Figure 2-9](#) shows the register chain interconnects.

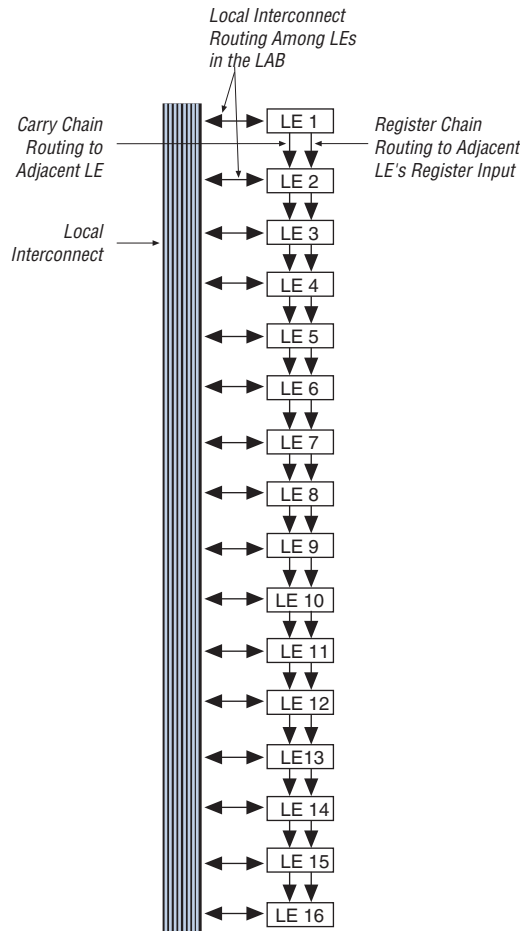
Figure 2–9. Register Chain Interconnects

The C4 interconnects span four LABs, M4K blocks, or embedded multipliers up or down from a source LAB. Every LAB has its own set of C4 interconnects to drive either up or down. [Figure 2–10](#) shows the C4 interconnect connections from an LAB in a column. The C4 interconnects can drive and be driven by all types of architecture blocks, including PLLs, M4K memory blocks, embedded multiplier blocks, and column and row IOEs. For LAB interconnection, a primary LAB or its LAB neighbor (see [Figure 2–10](#)) can drive a given C4 interconnect. C4 interconnects can drive each other to extend their range as well as drive row interconnects for column-to-column connections.

Figure 2-10. C4 Interconnect Connections Note (1)

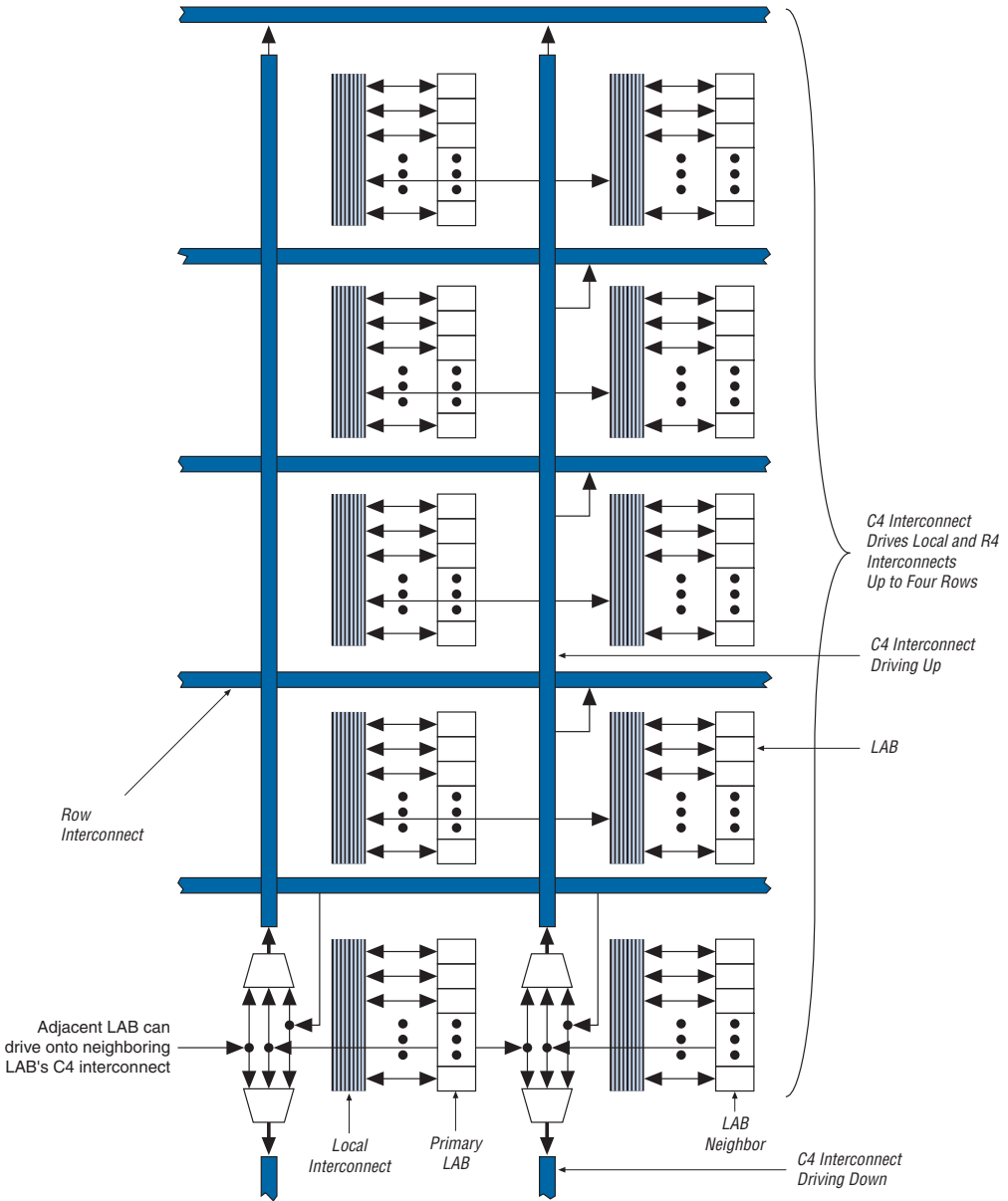

Note to Figure 2-10:

(1) Each C4 interconnect can drive either up or down four rows.

C16 column interconnects span a length of 16 LABs and provide the fastest resource for long column connections between LABs, M4K memory blocks, embedded multipliers, and IOEs. C16 column interconnects drive to other row and column interconnects at every fourth LAB. C16 column interconnects drive LAB local interconnects via C4 and R4 interconnects and do not drive LAB local interconnects directly. C16 interconnects can drive R24, R4, C16, and C4 interconnects.

Device Routing

All embedded blocks communicate with the logic array similar to LAB-to-LAB interfaces. Each block (for example, M4K memory, embedded multiplier, or PLL) connects to row and column interconnects and has local interconnect regions driven by row and column interconnects. These blocks also have direct link interconnects for fast connections to and from a neighboring LAB.

Table 2–2 shows the Cyclone II device’s routing scheme.

Table 2–2. Cyclone II Device Routing Scheme (Part 1 of 2)

Source	Destination												
	Register Chain	Local Interconnect	Direct Link Interconnect	R4 Interconnect	R24 Interconnect	C4 Interconnect	C16 Interconnect	LE	M4K RAM Block	Embedded Multiplier	PLL	Column IOE	Row IOE
Register Chain								✓					
Local Interconnect								✓	✓	✓	✓	✓	✓
Direct Link Interconnect		✓											
R4 Interconnect		✓		✓	✓	✓	✓						
R24 Interconnect				✓	✓	✓	✓						
C4 Interconnect		✓		✓	✓	✓	✓						
C16 Interconnect				✓	✓	✓	✓						

Table 2–2. Cyclone II Device Routing Scheme (Part 2 of 2)

Source	Destination												
	Register Chain	Local Interconnect	Direct Link Interconnect	R4 Interconnect	R24 Interconnect	C4 Interconnect	C16 Interconnect	LE	M4K RAM Block	Embedded Multiplier	PLL	Column IOE	Row IOE
LE	✓	✓	✓	✓		✓							
M4K memory Block		✓	✓	✓		✓							
Embedded Multipliers		✓	✓	✓		✓							
PLL			✓	✓		✓							
Column IOE						✓	✓						
Row IOE			✓	✓	✓	✓							

Global Clock Network & Phase-Locked Loops

Cyclone II devices provide global clock networks and up to four PLLs for a complete clock management solution. Cyclone II clock network features include:

- Up to 16 global clock networks
- Up to four PLLs
- Global clock network dynamic clock source selection
- Global clock network dynamic enable and disable

Each global clock network has a clock control block to select from a number of input clock sources (PLL clock outputs, CLK [] pins, DPCLK [] pins, and internal logic) to drive onto the global clock network. Table 2-3 lists how many PLLs, CLK [] pins, DPCLK [] pins, and global clock networks are available in each Cyclone II device. CLK [] pins are dedicated clock pins and DPCLK [] pins are dual-purpose clock pins.

Device	Number of PLLs	Number of CLK Pins	Number of DPCLK Pins	Number of Global Clock Networks
EP2C5	2	8	8	8
EP2C8	2	8	8	8
EP2C20	4	16	20	16
EP2C35	4	16	20	16
EP2C50	4	16	20	16
EP2C70	4	16	20	16

Figures 2-11 and 2-12 show the location of the Cyclone II PLLs, CLK [] inputs, DPCLK [] pins, and clock control blocks.

Figure 2-11. EP2C5 & EP2C8 PLL, CLK[], DPCLK[] & Clock Control Block Locations

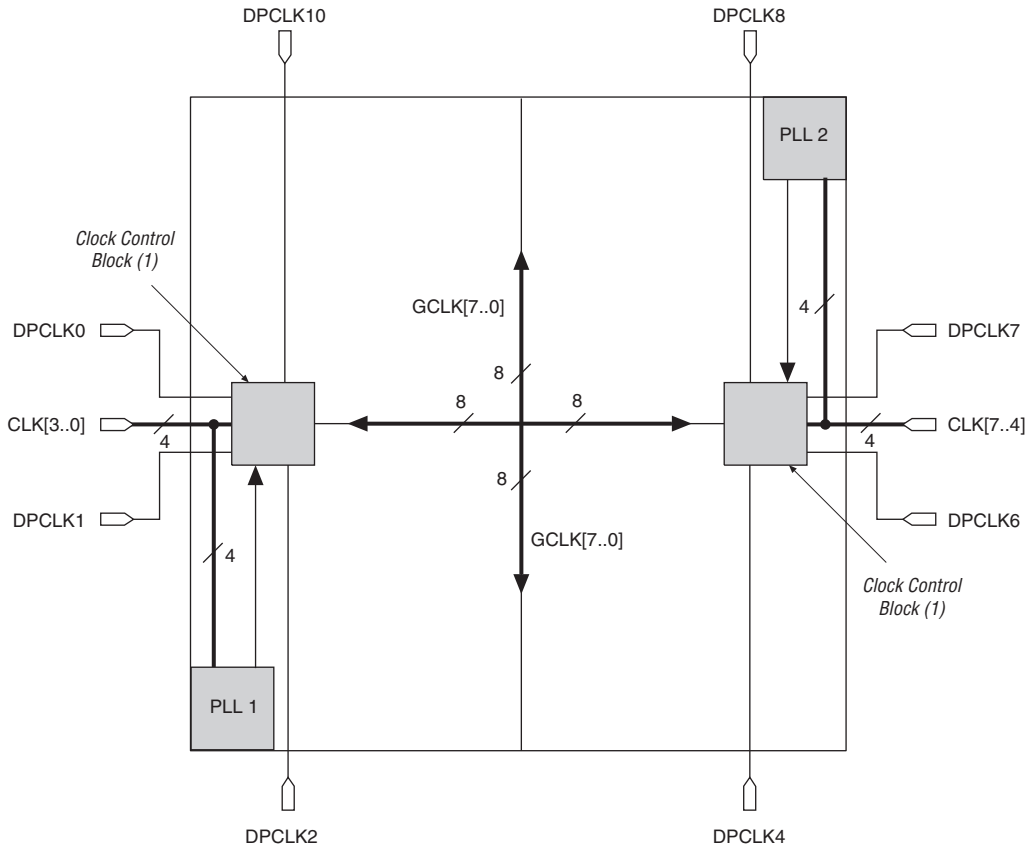

Note to Figure 2-11:

(1) There are four clock control blocks on each side.

Figure 2–12. EP2C20 & Larger PLL, CLK[], DPCLK[] & Clock Control Block Locations

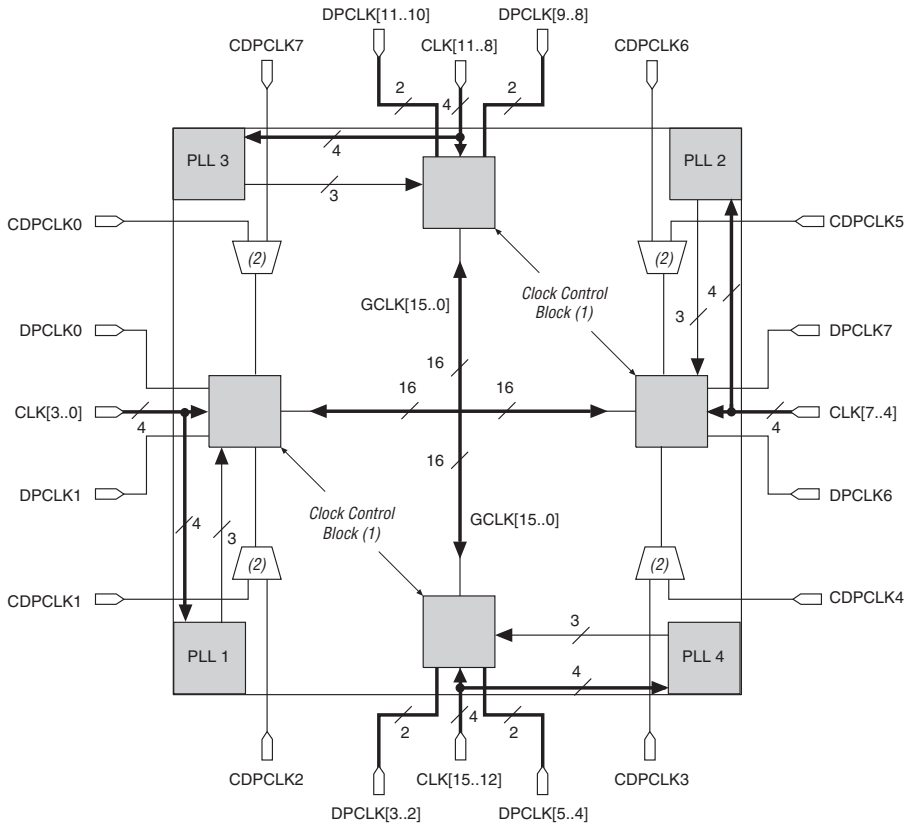

Notes to Figure 2–12:

- (1) There are four clock control blocks on each side.
- (2) Only one of the corner CDPCLK pins in each corner can feed the clock control block at a time. The other CDPCLK pins can be used as general-purpose I/O pins.

Dedicated Clock Pins

Larger Cyclone II devices (EP2C20 and larger devices) have 16 dedicated clock pins (CLK [15 . . 0], four pins on each side of the device). Smaller Cyclone II devices (EP2C5 and EP2C8 devices) have eight dedicated clock pins (CLK [7 . . 0], four pins on left and right sides of the device). These CLK pins drive the global clock network (GCLK), as shown in [Figures 2–11 and 2–12](#).

If the dedicated clock pins are not used to feed the global clock networks, they can be used as general-purpose input pins to feed the logic array using the MultiTrack interconnect. However, if they are used as general-purpose input pins, they do not have support for an I/O register and must use LE-based registers in place of an I/O register.

Dual-Purpose Clock Pins

Cyclone II devices have either 20 dual-purpose clock pins, DPCLK [19 . . 0] or 8 dual-purpose clock pins, DPCLK [7 . . 0]. In the larger Cyclone II devices (EP2C20 devices and higher), there are 20 DPCLK pins; four on the left and right sides and six on the top and bottom of the device. The corner CDPCLK pins are first multiplexed before they drive into the clock control block. Since the signals pass through a multiplexer before feeding the clock control block, these signals incur more delay to the clock control block than other DPCLK pins that directly feed the clock control block. In the smaller Cyclone II devices (EP2C5 and EP2C8 devices), there are eight DPCLK pins; two on each side of the device (see [Figures 2–11 and 2–12](#)).

A programmable delay chain is available from the DPCLK pin to its fan-out destinations. To set the propagation delay from the DPCLK pin to its fan-out destinations, use the **Input Delay from Dual-Purpose Clock Pin to Fan-Out Destinations** assignment in the Quartus II software.

These dual-purpose pins can connect to the global clock network for high-fanout control signals such as clocks, asynchronous clears, presets, and clock enables, or protocol control signals such as TRDY and IRDY for PCI, or DQS signals for external memory interfaces.

Global Clock Network

The 16 or 8 global clock networks drive throughout the entire device. Dedicated clock pins (CLK []), PLL outputs, the logic array, and dual-purpose clock (DPCLK []) pins can also drive the global clock network.

The global clock network can provide clocks for all resources within the device, such as IOEs, LEs, memory blocks, and embedded multipliers. The global clock lines can also be used for control signals, such as clock enables and synchronous or asynchronous clears fed from the external pin, or DQS signals for DDR SDRAM or QDR II SRAM interfaces. Internal logic can also drive the global clock network for internally generated global clocks and asynchronous clears, clock enables, or other control signals with large fan-out.

Clock Control Block

There is a clock control block for each global clock network available in Cyclone II devices. The clock control blocks are arranged on the device periphery and there are a maximum of 16 clock control blocks available per Cyclone II device. The larger Cyclone II devices (EP2C20 devices and larger) have 16 clock control blocks, four on each side of the device. The smaller Cyclone II devices (EP2C5 and EP2C8 devices) have eight clock control blocks, four on the left and right sides of the device.

The control block has these functions:

- Dynamic global clock network clock source selection
- Dynamic enable/disable of the global clock network

In Cyclone II devices, the dedicated CLK [] pins, PLL counter outputs, DPCLK [] pins, and internal logic can all feed the clock control block. The output from the clock control block in turn feeds the corresponding global clock network.

The following sources can be inputs to a given clock control block:

- Four clock pins on the same side as the clock control block
- Three PLL clock outputs from a PLL
- Four DPCLK pins (including CDPCLK pins) on the same side as the clock control block
- Four internally-generated signals

Of the sources listed, only two clock pins, two PLL clock outputs, one DPCLK pin, and one internally-generated signal are chosen to drive into a clock control block. Figure 2-13 shows a more detailed diagram of the clock control block. Out of these six inputs, the two clock input pins and two PLL outputs can be dynamic selected to feed a global clock network. The clock control block supports static selection of DPCLK and the signal from internal logic.

Figure 2-13. Clock Control Block

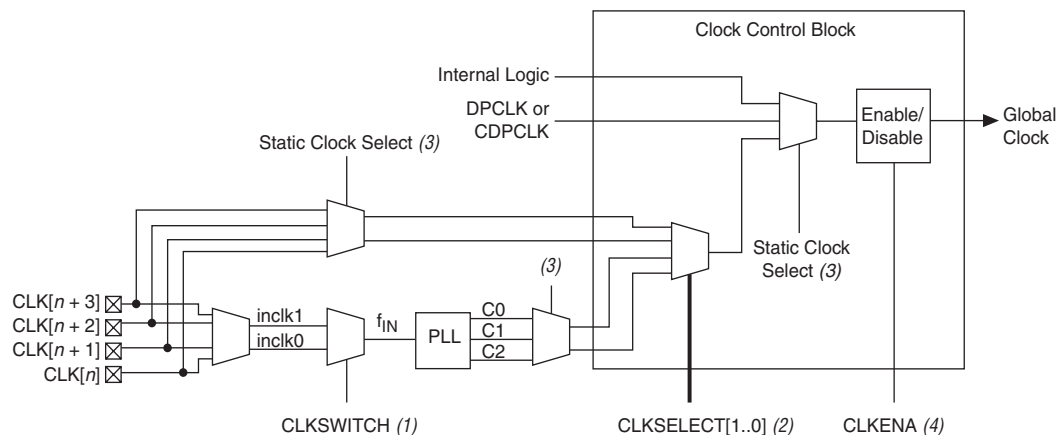

Notes to Figure 2-13:

- (1) The CLKSWITCH signal can either be set through the configuration file or it can be dynamically set when using the manual PLL switchover feature. The output of the multiplexer is the input reference clock (f_{IN}) for the PLL.
- (2) The CLKSELECT[1..0] signals are fed by internal logic and can be used to dynamically select the clock source for the global clock network when the device is in user mode.
- (3) The static clock select signals are set in the configuration file and cannot be dynamically controlled when the device is in user mode.
- (4) Internal logic can be used to enabled or disabled the global clock network in user mode.

Global Clock Network Distribution

Cyclone II devices contains 16 global clock networks. The device uses multiplexers with these clocks to form six-bit buses to drive column IOE clocks, LAB row clocks, or row IOE clocks (see [Figure 2-14](#)). Another multiplexer at the LAB level selects two of the six LAB row clocks to feed the LE registers within the LAB.

Figure 2-14. Global Clock Network Multiplexers

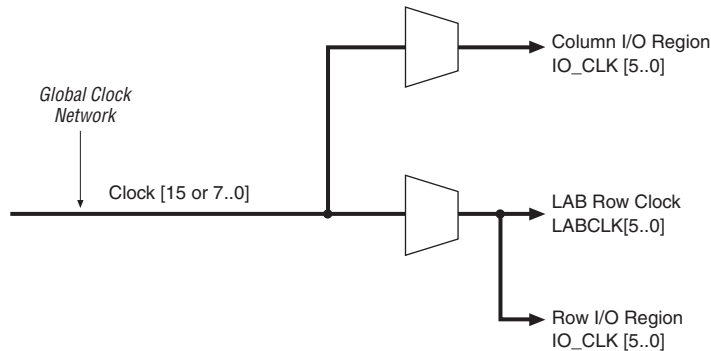

LAB row clocks can feed LEs, M4K memory blocks, and embedded multipliers. The LAB row clocks also extend to the row I/O clock regions.

IOE clocks are associated with row or column block regions. Only six global clock resources feed to these row and column regions. [Figure 2-15](#) shows the I/O clock regions.

Figure 2-15. LAB & I/O Clock Regions

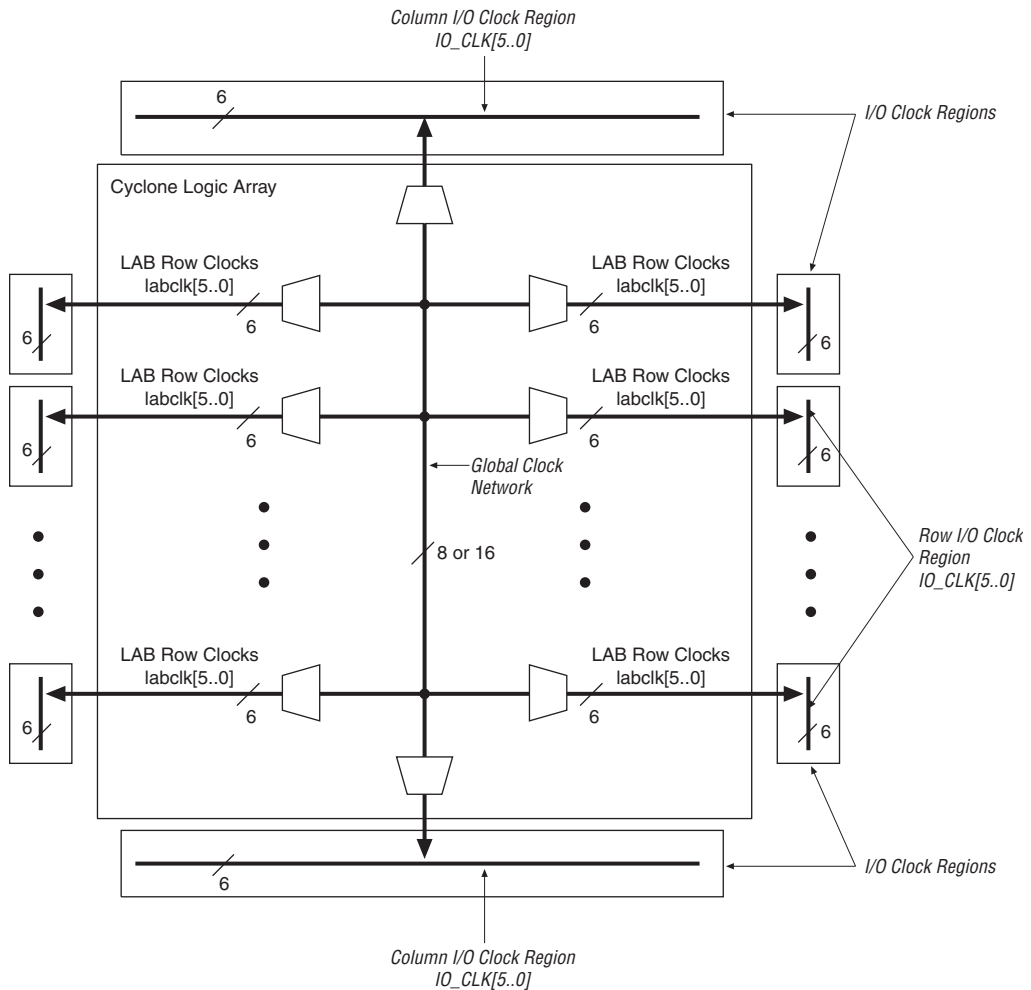

For more information on the global clock network and the clock control block, see the *PLLs in Cyclone II Devices* chapter in Volume 1 of the *Cyclone II Device Handbook*.

PLLs

Cyclone II PLLs provide general-purpose clocking as well as support for the following features:

- Clock multiplication and division
- Phase shifting
- Programmable duty cycle
- Up to three internal clock outputs
- One dedicated external clock output
- Clock outputs for differential I/O support
- Manual clock switchover
- Gated lock signal
- Three different clock feedback modes
- Control signals

Cyclone II devices contain either two or four PLLs. [Table 2-4](#) shows the PLLs available for each Cyclone II device.

Device	PLL1	PLL2	PLL3	PLL4
EP2C5	✓	✓		
EP2C8	✓	✓		
EP2C20	✓	✓	✓	✓
EP2C35	✓	✓	✓	✓
EP2C50	✓	✓	✓	✓
EP2C70	✓	✓	✓	✓

Table 2-5 describes the PLL features in Cyclone II devices.

Table 2-5. Cyclone II PLL Features	
Feature	Description
Clock multiplication and division	$m / (n \times \text{post-scale counter})$ m and post-scale counter values (C0 to C2) range from 1 to 32. n ranges from 1 to 4.
Phase shift	Cyclone II PLLs have an advanced clock shift capability that enables programmable phase shifts in increments of at least 45°. The finest resolution of phase shifting is determined by the voltage control oscillator (VCO) period divided by 8 (for example, 1/1000 MHz/8 = down to 125-ps increments).
Programmable duty cycle	The programmable duty cycle allows PLLs to generate clock outputs with a variable duty cycle. This feature is supported on each PLL post-scale counter (C0-C2).
Number of internal clock outputs	The Cyclone II PLL has three outputs which can drive the global clock network. One of these outputs (C2) can also drive a dedicated PLL<#>_OUT pin (single ended or differential).
Number of external clock outputs	The C2 output drives a dedicated PLL<#>_OUT pin. If the C2 output is not used to drive an external clock output, it can be used to drive the internal global clock network. The C2 output can concurrently drive the external clock output and internal global clock network.
Manual clock switchover	The Cyclone II PLLs support manual switchover of the reference clock through internal logic. This enables you to switch between two reference input clocks during user mode for applications that may require clock redundancy or support for clocks with two different frequencies.
Gated lock signal	The lock output indicates that there is a stable clock output signal in phase with the reference clock. Cyclone II PLLs include a programmable counter that holds the lock signal low for a user-selected number of input clock transitions, allowing the PLL to lock before enabling the locked signal. Either a gated locked signal or an ungated locked signal from the locked port can drive internal logic or an output pin.
Clock feedback modes	In zero delay buffer mode, the external clock output pin is phase-aligned with the clock input pin for zero delay. In normal mode, the PLL compensates for the internal global clock network delay from the input clock pin to the clock port of the IOE output registers or registers in the logic array. In no compensation mode, the PLL does not compensate for any clock networks.
Control signals	The <code>pllenable</code> signal enables and disables the PLLs. The <code>areset</code> signal resets/resynchronizes the inputs for each PLL. The <code>pfdena</code> signal controls the phase frequency detector (PFD) output with a programmable gate.

Each M4K block can implement various types of memory with or without parity, including true dual-port, simple dual-port, and single-port RAM, ROM, and first-in first-out (FIFO) buffers. The M4K blocks support the following features:

- 4,608 RAM bits
- 250-MHz performance
- True dual-port memory
- Simple dual-port memory
- Single-port memory
- Byte enable
- Parity bits
- Shift register
- FIFO buffer
- ROM
- Various clock modes
- Address clock enable



Violating the setup or hold time on the memory block address registers could corrupt memory contents. This applies to both read and write operations.

Table 2-6 shows the capacity and distribution of the M4K memory blocks in each Cyclone II device.

Table 2-6. M4K Memory Capacity & Distribution in Cyclone II Devices			
Device	M4K Columns	M4K Blocks	Total RAM Bits
EP2C5	2	26	119,808
EP2C8	2	36	165,888
EP2C20	2	52	239,616
EP2C35	3	105	483,840
EP2C50	3	129	594,432
EP2C70	5	250	1,152,000

Table 2-7 summarizes the features supported by the M4K memory.

Table 2-7. M4K Memory Features	
Feature	Description
Maximum performance (1)	250 MHz
Total RAM bits per M4K block (including parity bits)	4,608
Configurations supported	4K × 1 2K × 2 1K × 4 512 × 8 512 × 9 256 × 16 256 × 18 128 × 32 (not available in true dual-port mode) 128 × 36 (not available in true dual-port mode)
Parity bits	One parity bit for each byte. The parity bit, along with internal user logic, can implement parity checking for error detection to ensure data integrity.
Byte enable	M4K blocks support byte writes when the write port has a data width of 1, 2, 4, 8, 9, 16, 18, 32, or 36 bits. The byte enables allow the input data to be masked so the device can write to specific bytes. The unwritten bytes retain the previous written value.
Packed mode	Two single-port memory blocks can be packed into a single M4K block if each of the two independent block sizes are equal to or less than half of the M4K block size, and each of the single-port memory blocks is configured in single-clock mode.
Address clock enable	M4K blocks support address clock enable, which is used to hold the previous address value for as long as the signal is enabled. This feature is useful in handling misses in cache applications.
Memory initialization file (.mif)	When configured as RAM or ROM, you can use an initialization file to pre-load the memory contents.
Power-up condition	Outputs cleared
Register clears	Output registers only
Same-port read-during-write	New data available at positive clock edge
Mixed-port read-during-write	Old data available at positive clock edge

Note to Table 2-7:

(1) Maximum performance information is preliminary until device characterization.

Clear Signals

When applied to input registers, the asynchronous clear signal for the TriMatrix™ embedded memory immediately clears the input registers. However, the output of the memory block does not show the effects until the next clock edge. When applied to output registers, the asynchronous clear signal clears the output registers and the effects are seen immediately.

Memory Modes

Table 2–8 summarizes the different memory modes supported by the M4K memory blocks.

Memory Mode	Description
Single-port memory	M4K blocks support single-port mode, used when simultaneous reads and writes are not required. Single-port memory supports non-simultaneous reads and writes.
Simple dual-port memory	Simple dual-port memory supports a simultaneous read and write.
Simple dual-port with mixed width	Simple dual-port memory mode with different read and write port widths.
True dual-port memory	True dual-port mode supports any combination of two-port operations: two reads, two writes, or one read and one write at two different clock frequencies.
True dual-port with mixed width	True dual-port mode with different read and write port widths.
Embedded shift register	M4K memory blocks are used to implement shift registers. Data is written into each address location at the falling edge of the clock and read from the address at the rising edge of the clock.
ROM	The M4K memory blocks support ROM mode. A MIF initializes the ROM contents of these blocks.
FIFO buffers	A single clock or dual clock FIFO may be implemented in the M4K blocks. Simultaneous read and write from an empty FIFO buffer is not supported.



Embedded Memory can be inferred in your HDL code or directly instantiated in the Quartus II software using the MegaWizard® Plug-in Manager Memory Compiler feature.

Clock Modes

Table 2–9 summarizes the different clock modes supported by the M4K memory.

Table 2–9. M4K Clock Modes	
Clock Mode	Description
Independent	In this mode, a separate clock is available for each port (ports A and B). Clock A controls all registers on the port A side, while clock B controls all registers on the port B side.
Input/output	On each of the two ports, A or B, one clock controls all registers for inputs into the memory block: data input, <i>wren</i> , and address. The other clock controls the block's data output registers.
Read/write	Up to two clocks are available in this mode. The write clock controls the block's data inputs, <i>wraddress</i> , and <i>wren</i> . The read clock controls the data output, <i>rdaddress</i> , and <i>rden</i> .
Single	In this mode, a single clock, together with clock enable, is used to control all registers of the memory block. Asynchronous clear signals for the registers are not supported.

Table 2–10 shows which clock modes are supported by all M4K blocks when configured in the different memory modes.

Table 2–10. Cyclone II M4K Memory Clock Modes			
Clocking Modes	True Dual-Port Mode	Simple Dual-Port Mode	Single-Port Mode
Independent	✓		
Input/output	✓	✓	✓
Read/write		✓	
Single clock	✓	✓	✓

M4K Routing Interface

The R4, C4, and direct link interconnects from adjacent LABs drive the M4K block local interconnect. The M4K blocks can communicate with LABs on either the left or right side through these row resources or with LAB columns on either the right or left with the column resources. Up to 16 direct link input connections to the M4K block are possible from the left adjacent LAB and another 16 possible from the right adjacent LAB. M4K block outputs can also connect to left and right LABs through each 16 direct link interconnects. Figure 2–17 shows the M4K block to logic array interface.

Figure 2–17. M4K RAM Block LAB Row Interface

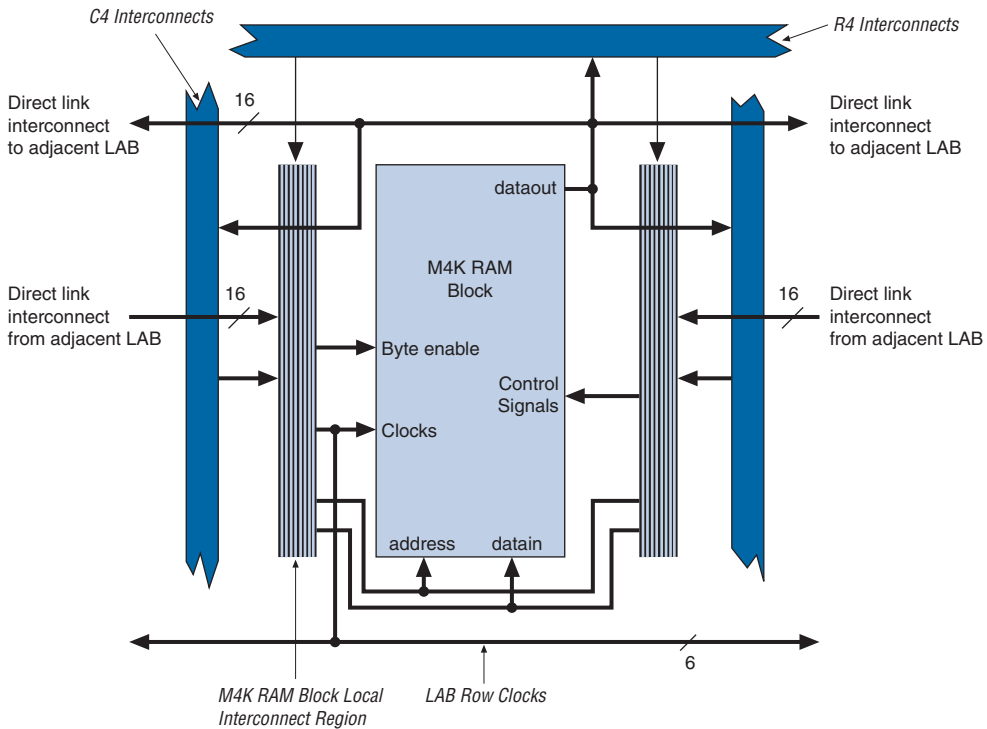

For more information on Cyclone II embedded memory, see the *Cyclone II Memory Blocks* chapter in Volume 1 of the *Cyclone II Device Handbook*.

Embedded Multipliers

Cyclone II devices have embedded multiplier blocks optimized for multiplier-intensive digital signal processing (DSP) functions, such as finite impulse response (FIR) filters, fast Fourier transform (FFT) functions, and discrete cosine transform (DCT) functions. You can use the embedded multiplier in one of two basic operational modes, depending on the application needs:

- One 18-bit multiplier
- Up to two independent 9-bit multipliers

Embedded multipliers can operate at up to 250 MHz (for the fastest speed grade) for 18×18 and 9×9 multiplications when using both input and output registers.

Each Cyclone II device has one to three columns of embedded multipliers that efficiently implement multiplication functions. An embedded multiplier spans the height of one LAB row. [Table 2–11](#) shows the number of embedded multipliers in each Cyclone II device and the multipliers that can be implemented.

Device	Embedded Multiplier Columns	Embedded Multipliers	9×9 Multipliers	18×18 Multipliers
EP2C5	1	13	26	13
EP2C8	1	18	36	18
EP2C20	1	26	52	26
EP2C35	1	35	70	35
EP2C50	2	86	172	86
EP2C70	3	150	300	150

Note to Table 2–11:

- (1) Each device has either the number of 9×9 -, or 18×18 -bit multipliers shown. The total number of multipliers for each device is not the sum of all the multipliers.

The embedded multiplier consists of the following elements:

- Multiplier block
- Input and output registers
- Input and output interfaces

[Figure 2–18](#) shows the multiplier block architecture.

Figure 2–18. Multiplier Block Architecture

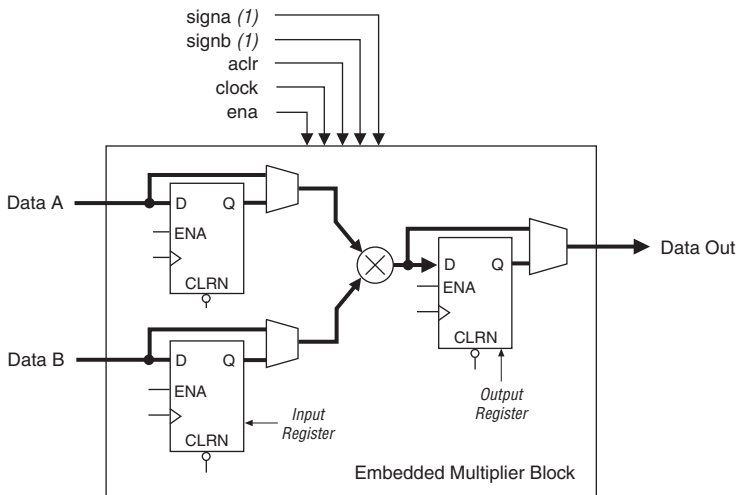

Note to Figure 2–18:

(1) If necessary, these signals can be registered once to match the data signal path.

Each multiplier operand can be a unique signed or unsigned number. Two signals, *signa* and *signb*, control the representation of each operand respectively. A logic 1 value on the *signa* signal indicates that data A is a signed number while a logic 0 value indicates an unsigned number. Table 2–12 shows the sign of the multiplication result for the various operand sign representations. The result of the multiplication is signed if any one of the operands is a signed value.

Data A (signa Value)	Data B (signb Value)	Result
Unsigned	Unsigned	Unsigned
Unsigned	Signed	Signed
Signed	Unsigned	Signed
Signed	Signed	Signed

There is only one `signa` and one `signb` signal for each dedicated multiplier. Therefore, all of the data A inputs feeding the same dedicated multiplier must have the same sign representation. Similarly, all of the data B inputs feeding the same dedicated multiplier must have the same sign representation. The `signa` and `signb` signals can be changed dynamically to modify the sign representation of the input operands at run time. The multiplier offers full precision regardless of the sign representation and can be registered using dedicated registers located at the input register stage.

Multiplier Modes

Table 2–13 summarizes the different modes that the embedded multipliers can operate in.

Multiplier Mode	Description
18-bit Multiplier	An embedded multiplier can be configured to support a single 18×18 multiplier for operand widths up to 18 bits. All 18-bit multiplier inputs and results can be registered independently. The multiplier operands can accept signed integers, unsigned integers, or a combination of both.
9-bit Multiplier	An embedded multiplier can be configured to support two 9×9 independent multipliers for operand widths up to 9-bits. Both 9-bit multiplier inputs and results can be registered independently. The multiplier operands can accept signed integers, unsigned integers or a combination of both. There is only one <code>signa</code> signal to control the sign representation of both data A inputs and one <code>signb</code> signal to control the sign representation of both data B inputs of the 9-bit multipliers within the same dedicated multiplier.

Embedded Multiplier Routing Interface

The R4, C4, and direct link interconnects from adjacent LABs drive the embedded multiplier row interface interconnect. The embedded multipliers can communicate with LABs on either the left or right side through these row resources or with LAB columns on either the right or left with the column resources. Up to 16 direct link input connections to the embedded multiplier are possible from the left adjacent LABs and another 16 possible from the right adjacent LAB. Embedded multiplier outputs can also connect to left and right LABs through 18 direct link interconnects each. **Figure 2-19** shows the embedded multiplier to logic array interface.

Figure 2-19. Embedded Multiplier LAB Row Interface

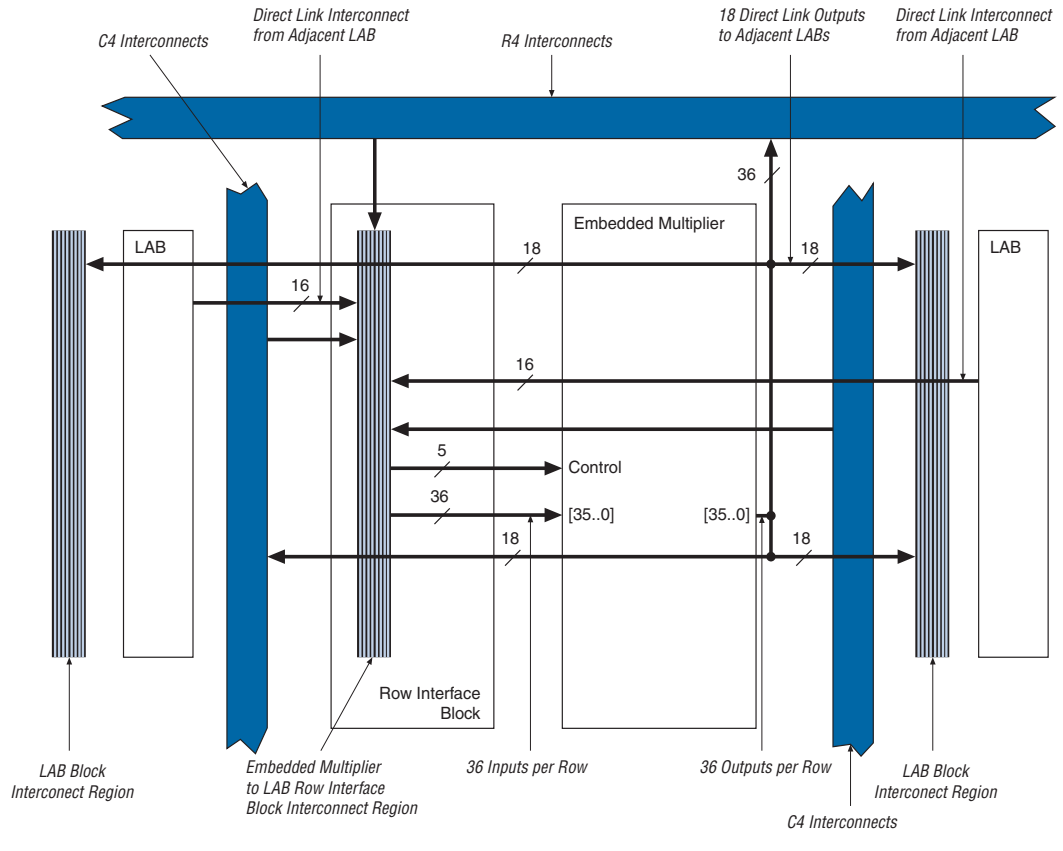

There are five dynamic control input signals that feed the embedded multiplier: `signa`, `signb`, `clk`, `clkena`, and `aclr`. `signa` and `signb` can be registered to match the data signal input path. The same `clk`, `clkena`, and `aclr` signals feed all registers within a single embedded multiplier.



For more information on Cyclone II embedded multipliers, see the *Embedded Multipliers in Cyclone II Devices* chapter.

I/O Structure & Features

IOEs support many features, including:

- Differential and single-ended I/O standards
- 3.3-V, 64- and 32-bit, 66- and 33-MHz PCI compliance
- Joint Test Action Group (JTAG) boundary-scan test (BST) support
- Output drive strength control
- Weak pull-up resistors during configuration
- Tri-state buffers
- Bus-hold circuitry
- Programmable pull-up resistors in user mode
- Programmable input and output delays
- Open-drain outputs
- DQ and DQS I/O pins
- V_{REF} pins

Cyclone II device IOEs contain a bidirectional I/O buffer and three registers for complete embedded bidirectional single data rate transfer. [Figure 2–20](#) shows the Cyclone II IOE structure. The IOE contains one input register, one output register, and one output enable register. You can use the input registers for fast setup times and output registers for fast clock-to-output times. Additionally, you can use the output enable (OE) register for fast clock-to-output enable timing. The Quartus II software automatically duplicates a single OE register that controls multiple output or bidirectional pins. You can use IOEs as input, output, or bidirectional pins.

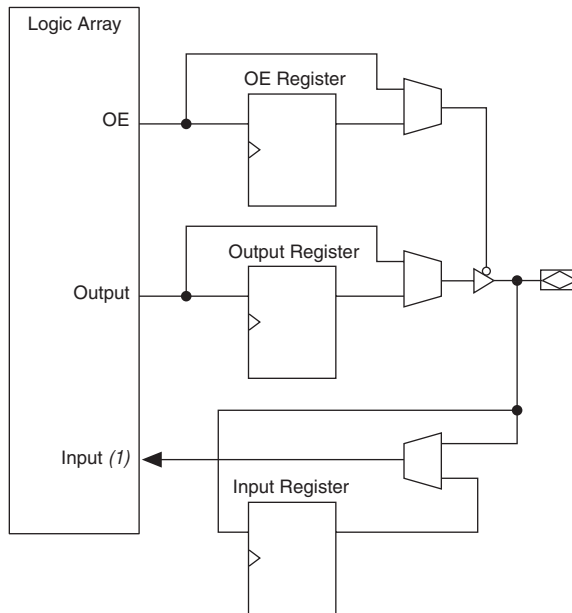
Figure 2–20. Cyclone II IOE Structure**Note to Figure 2–20:**

- (1) There are two paths available for combinational or registered inputs to the logic array. Each path contains a unique programmable delay chain.

The IOEs are located in I/O blocks around the periphery of the Cyclone II device. There are up to five IOEs per row I/O block and up to four IOEs per column I/O block (column I/O blocks span two columns). The row I/O blocks drive row, column (only C4 interconnects), or direct link interconnects. The column I/O blocks drive column interconnects.

Figure 2–21 shows how a row I/O block connects to the logic array.

Figure 2–22 shows how a column I/O block connects to the logic array.

Figure 2–21. Row I/O Block Connection to the Interconnect

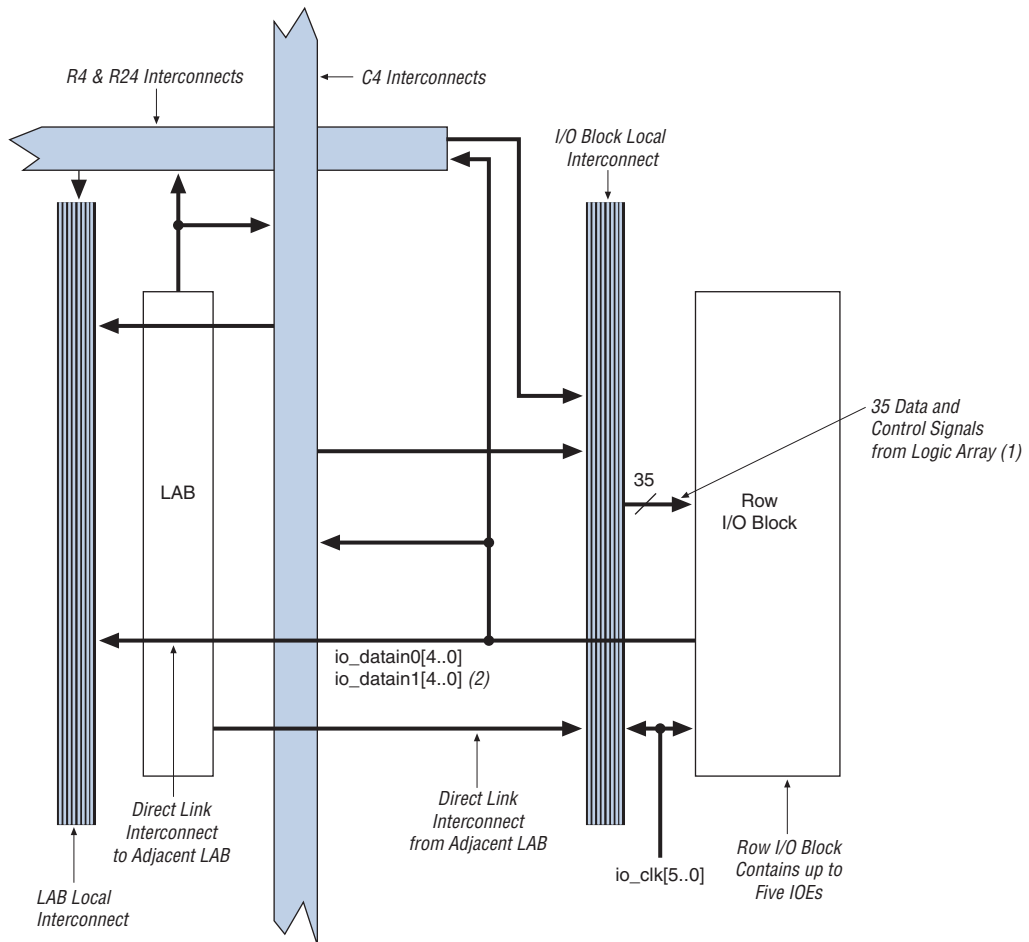
**Notes to Figure 2–21:**

- (1) The 35 data and control signals consist of five data out lines, $io_dataout[4..0]$, five output enables, $io_coe[4..0]$, five input clock enables, $io_cce_in[4..0]$, five output clock enables, $io_cce_out[4..0]$, five clocks, $io_cclk[4..0]$, five asynchronous clear signals, $io_cac1r[4..0]$, and five synchronous clear signals, $io_csc1r[4..0]$.
- (2) Each of the five IOEs in the row I/O block can have two io_datain (combinational or registered) inputs.

Figure 2–22. Column I/O Block Connection to the Interconnect

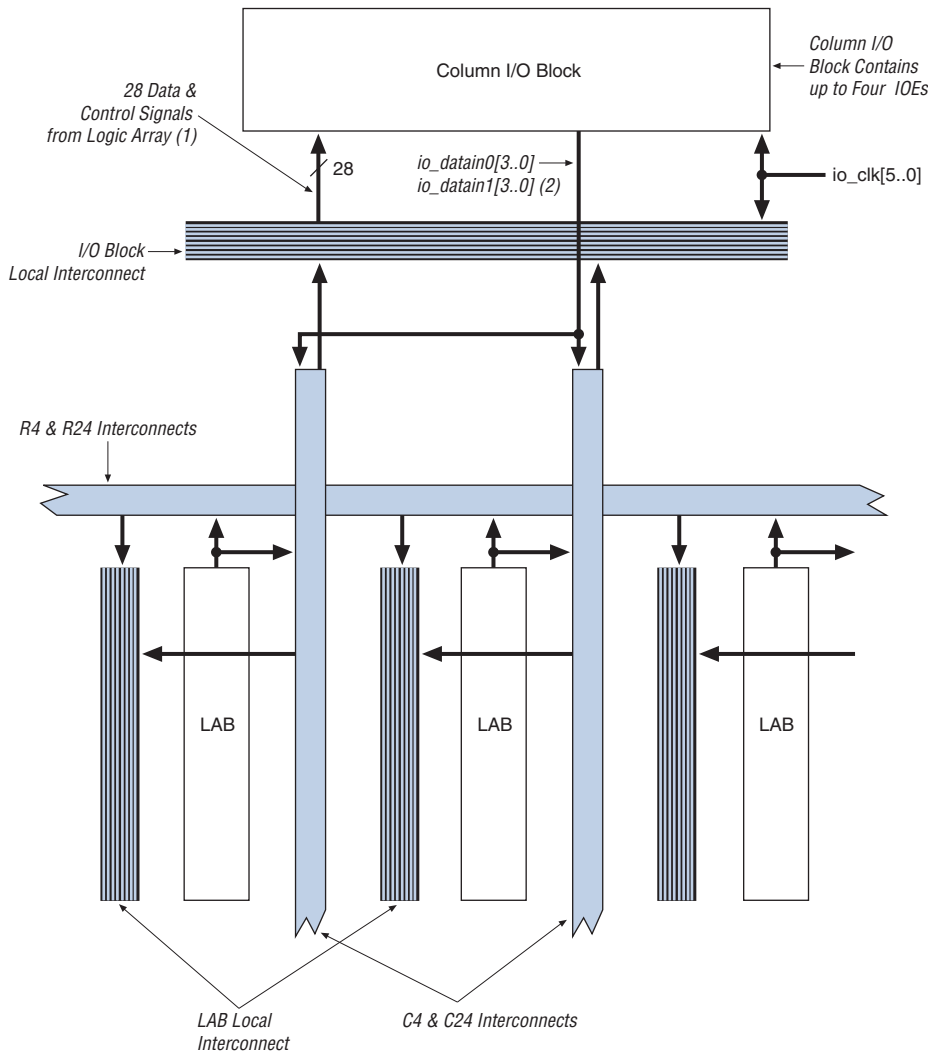
**Notes to Figure 2–22:**

- (1) The 28 data and control signals consist of four data out lines, `io_dataout[3..0]`, four output enables, `io_coe[3..0]`, four input clock enables, `io_cce_in[3..0]`, four output clock enables, `io_cce_out[3..0]`, four clocks, `io_clk[3..0]`, four asynchronous clear signals, `io_caclr[3..0]`, and four synchronous clear signals, `io_csclr[3..0]`.
- (2) Each of the four IOEs in the column I/O block can have two `io_datain` (combinational or registered) inputs.

The pin's data in signals can drive the logic array. The logic array drives the control and data signals, providing a flexible routing resource. The row or column IOE clocks, `io_clk[5..0]`, provide a dedicated routing resource for low-skew, high-speed clocks. The global clock network generates the IOE clocks that feed the row or column I/O regions (see “Global Clock Network & Phase-Locked Loops” on page 2-16). Figure 2-23 illustrates the signal paths through the I/O block.

Figure 2-23. Signal Path Through the I/O Block

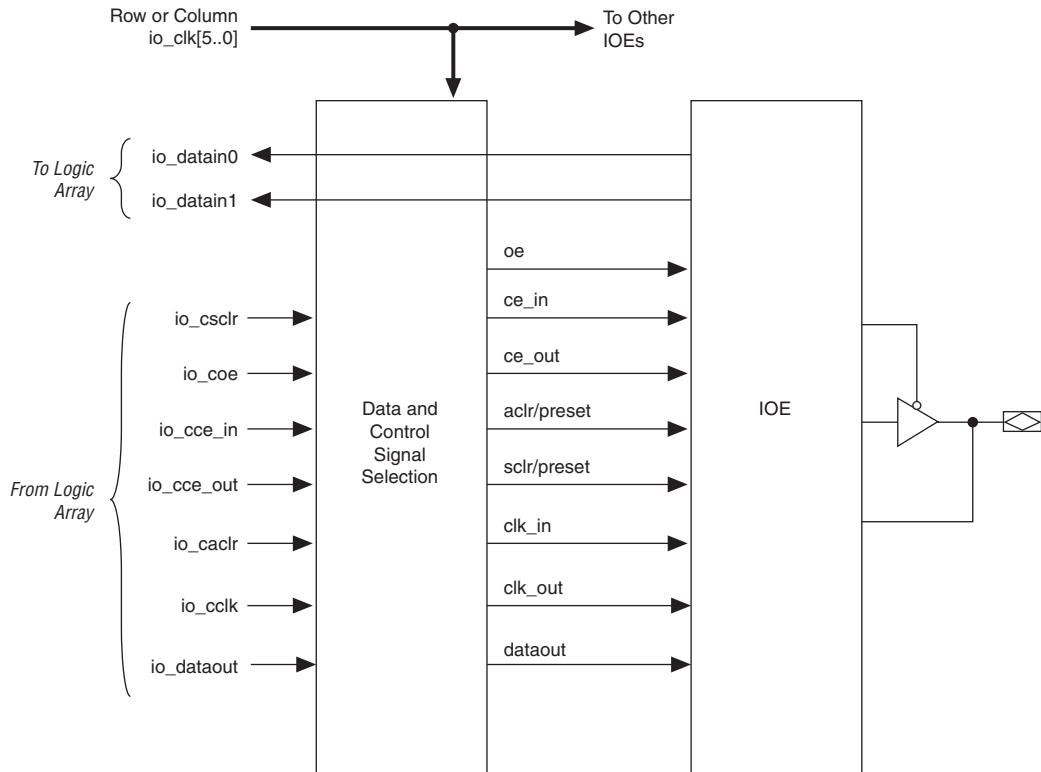

Each IOE contains its own control signal selection for the following control signals: `oe`, `ce_in`, `ce_out`, `aclr/preset`, `sclr/preset`, `clk_in`, and `clk_out`. Figure 2-24 illustrates the control signal selection.

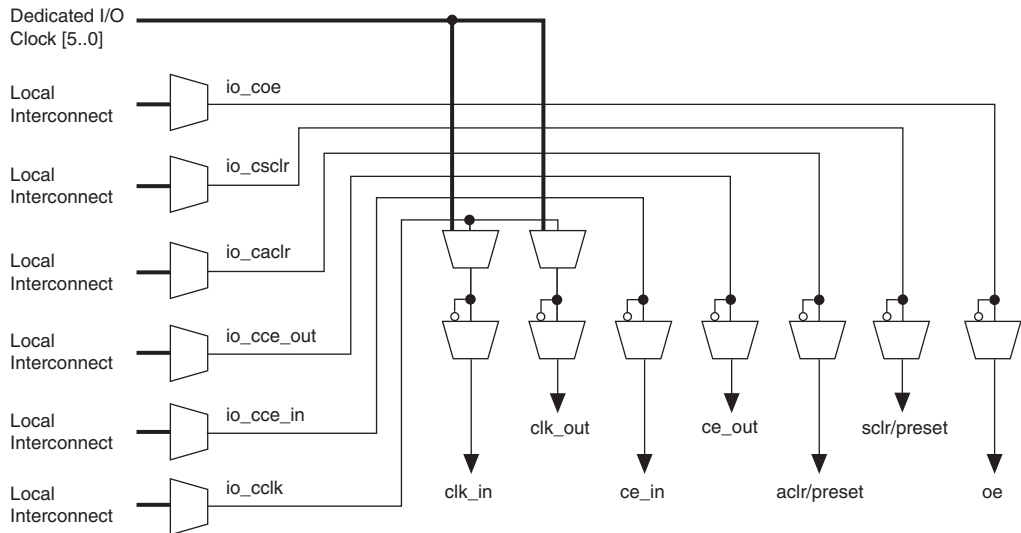
Figure 2–24. Control Signal Selection per IOE

In normal bidirectional operation, you can use the input register for input data requiring fast setup times. The input register can have its own clock input and clock enable separate from the OE and output registers. You can use the output register for data requiring fast clock-to-output performance. The OE register is available for fast clock-to-output enable timing. The OE and output register share the same clock source and the same clock enable source from the local interconnect in the associated LAB, dedicated I/O clocks, or the column and row interconnects. All registers share `sclr` and `acclr`, but each register can individually disable `sclr` and `acclr`. [Figure 2–25](#) shows the IOE in bidirectional configuration.

Figure 2–25. Cyclone II IOE in Bidirectional I/O Configuration

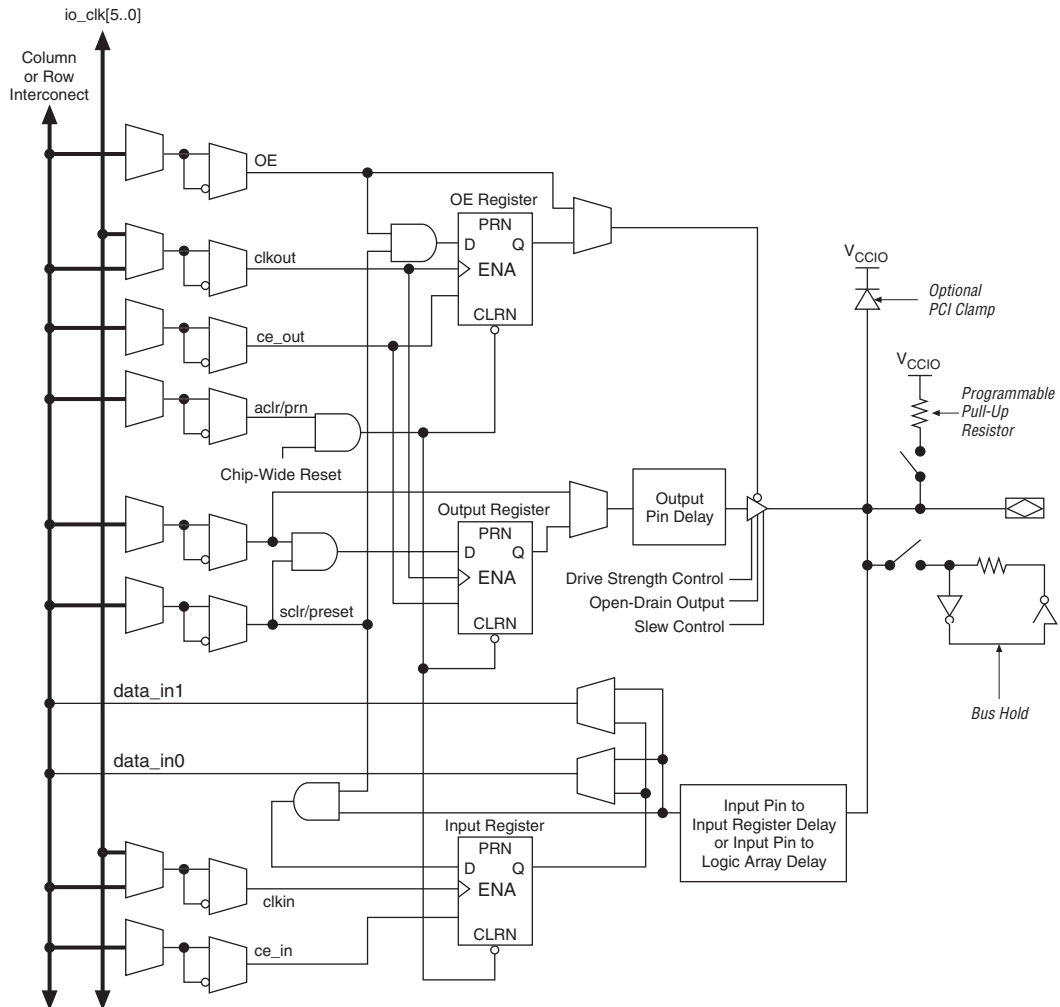

The Cyclone II device IOE includes programmable delays to ensure zero hold times, minimize setup times, or increase clock to output times.

A path in which a pin directly drives a register may require a programmable delay to ensure zero hold time, whereas a path in which a pin drives a register through combinational logic may not require the delay. Programmable delays decrease input-pin-to-logic-array and IOE input register delays. The Quartus II Compiler can program these delays to automatically minimize setup time while providing a zero hold time.

Programmable delays can increase the register-to-pin delays for output registers. Table 2–14 shows the programmable delays for Cyclone II devices.

Programmable Delays	Quartus II Logic Option
Input pin to logic array delay	Input delay from pin to internal cells
Input pin to input register delay	Input delay from pin to input register
Output pin delay	Delay from output register to output pin

There are two paths in the IOE for an input to reach the logic array. Each of the two paths can have a different delay. This allows you to adjust delays from the pin to internal LE registers that reside in two different areas of the device. You set the two combinational input delays by selecting different delays for two different paths under the **Input delay from pin to internal cells logic** option in the Quartus II software. However, if the pin uses the input register, one of delays is disregarded because the IOE only has two paths to internal logic. If the input register is used, the IOE uses one input path. The other input path is then available for the combinational path, and only one input delay assignment is applied.

The IOE registers in each I/O block share the same source for clear or preset. You can program preset or clear for each individual IOE, but both features cannot be used simultaneously. You can also program the registers to power up high or low after configuration is complete. If programmed to power up low, an asynchronous clear can control the registers. If programmed to power up high, an asynchronous preset can control the registers. This feature prevents the inadvertent activation of another device's active-low input upon power up. If one register in an IOE uses a preset or clear signal then all registers in the IOE must use that same signal if they require preset or clear. Additionally a synchronous reset signal is available for the IOE registers.

External Memory Interfacing

Cyclone II devices support a broad range of external memory interfaces such as SDR SDRAM, DDR SDRAM, DDR2 SDRAM, and QDR II SRAM external memories. Cyclone II devices feature dedicated high-speed interfaces that transfer data between external memory devices at up to 167 MHz/333 Mbps for DDR and DDR2 SDRAM devices and 167 MHz/667 Mbps for QDR II SRAM devices. The programmable DQS delay chain allows you to fine tune the phase shift for the input clocks or strobes to properly align clock edges as needed to capture data.

In Cyclone II devices, all the I/O banks support SDR and DDR SDRAM memory up to 167 MHz/333 Mbps. All I/O banks support DQS signals with the DQ bus modes of $\times 8/\times 9$, or $\times 16/\times 18$. Table 2–15 shows the external memory interfaces supported in Cyclone II devices.

Memory Standard	I/O Standard	Maximum Bus Width	Maximum Clock Rate Supported (MHz)	Maximum Data Rate Supported (Mbps)
SDR SDRAM	LVTTTL (2)	72	167	167
DDR SDRAM	SSTL-2 class I (2)	72	167	333 (1)
	SSTL-2 class II (2)	72	133	267 (1)
DDR2 SDRAM	SSTL-18 class I (2)	72	167	333 (1)
	SSTL-18 class II (3)	72	125	250 (1)
QDRII SRAM (4)	1.8-V HSTL class I (2)	36	167	668 (1)
	1.8-V HSTL class II (3)	36	100	400 (1)

Notes to Table 2–15:

- (1) The data rate is for designs using the Clock Delay Control circuitry.
- (2) The I/O standards are supported on all the I/O banks of the Cyclone II device.
- (3) The I/O standards are supported only on the I/O banks on the top and bottom of the Cyclone II device.
- (4) For maximum performance, Altera recommends using the 1.8-V HSTL I/O standard because of higher I/O drive strength. QDRII SRAM devices also support the 1.5-V HSTL I/O standard.

Cyclone II devices use data (DQ), data strobe (DQS), and clock pins to interface with external memory. Figure 2–26 shows the DQ and DQS pins in the $\times 8/\times 9$ mode.

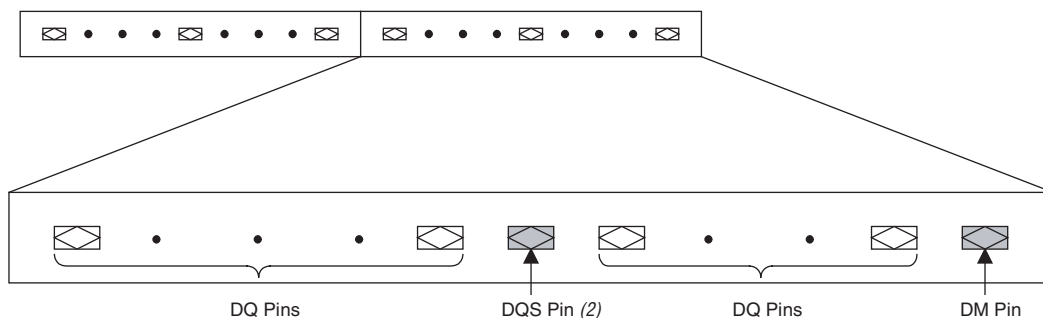
Figure 2–26. Cyclone II Device DQ & DQS Groups in $\times 8/\times 9$ Mode *Notes (1), (2)***Notes to Figure 2–26:**

- (1) Each DQ group consists of a DQS pin, DM pin, and up to nine DQ pins.
- (2) This is an idealized pin layout. For actual pin layout, refer to the pin table.

Cyclone II devices support the data strobe or read clock signal (DQS) used in DDR and DDR2 SDRAM. Cyclone II devices can use either bidirectional data strobes or unidirectional read clocks. The dedicated external memory interface in Cyclone II devices also includes programmable delay circuitry that can shift the incoming DQS signals to center align the DQS signals within the data window.

The DQS signal is usually associated with a group of data (DQ) pins. The phase-shifted DQS signals drive the global clock network, which is used to clock the DQ signals on internal LE registers.

Table 2–16 shows the number of DQ pin groups per device.

Table 2–16. Cyclone II DQS & DQ Bus Mode Support (Part 1 of 2) *Note (1)*

Device	Package	Number of $\times 8$ Groups	Number of $\times 9$ Groups (5), (6)	Number of $\times 16$ Groups	Number of $\times 18$ Groups (5), (6)
EP2C5	144-pin TQFP (2)	3	3	0	0
	208-pin PQFP	7 (3)	4	3	3
EP2C8	144-pin TQFP (2)	3	3	0	0
	208-pin PQFP	7 (3)	4	3	3
	256-pin FineLine BGA®	8 (3)	4	4	4
EP2C20	256-pin FineLine BGA	8	4	4	4
	484-pin FineLine BGA	16 (4)	8	8	8
EP2C35	484-pin FineLine BGA	16 (4)	8	8	8
	672-pin FineLine BGA	20 (4)	8	8	8

Table 2–16. Cyclone II DQS & DQ Bus Mode Support (Part 2 of 2) *Note (1)*

Device	Package	Number of $\times 8$ Groups	Number of $\times 9$ Groups (5), (6)	Number of $\times 16$ Groups	Number of $\times 18$ Groups (5), (6)
EP2C50	484-pin FineLine BGA	16 (4)	8	8	8
	672-pin FineLine BGA	20 (4)	8	8	8
EP2C70	672-pin FineLine BGA	20 (4)	8	8	8
	896-pin FineLine BGA	20 (4)	8	8	8

Notes to Table 2–16:

- (1) Numbers are preliminary.
- (2) EP2C5 and EP2C8 devices in the 144-pin TQFP package do not have any DQ pin groups in I/O bank 1.
- (3) Because of available clock resources, only a total of 6 DQ/DQS groups can be implemented.
- (4) Because of available clock resources, only a total of 14 DQ/DQS groups can be implemented.
- (5) The $\times 9$ DQS/DQ groups are also used as $\times 8$ DQS/DQ groups. The $\times 18$ DQS/DQ groups are also used as $\times 16$ DQS/DQ groups.
- (6) For QDRI implementation, if you connect the D ports (write data) to the Cyclone II DQ pins, the total available $\times 9$ DQS /DQ and $\times 18$ DQS/DQ groups are half of that shown in Table 2–16.

You can use any of the DQ pins for the parity pins in Cyclone II devices. The Cyclone II device family supports parity in the $\times 8/\times 9$, and $\times 16/\times 18$ mode. There is one parity bit available per eight bits of data pins.

The data mask, DM, pins are required when writing to DDR SDRAM and DDR2 SDRAM devices. A low signal on the DM pin indicates that the write is valid. If the DM signal is high, the memory masks the DQ signals. In Cyclone II devices, the DM pins are assigned and are the preferred pins. Each group of DQS and DQ signals requires a DM pin.

When using the Cyclone II I/O banks to interface with the DDR memory, at least one PLL with two clock outputs is needed to generate the system and write clock. The system clock is used to clock the DQS write signals, commands, and addresses. The write clock is shifted by -90° from the system clock and is used to clock the DQ signals during writes.

Figure 2–27 illustrates DDR SDRAM interfacing from the I/O through the dedicated circuitry to the logic array.

Figure 2-27. DDR SDRAM Interfacing

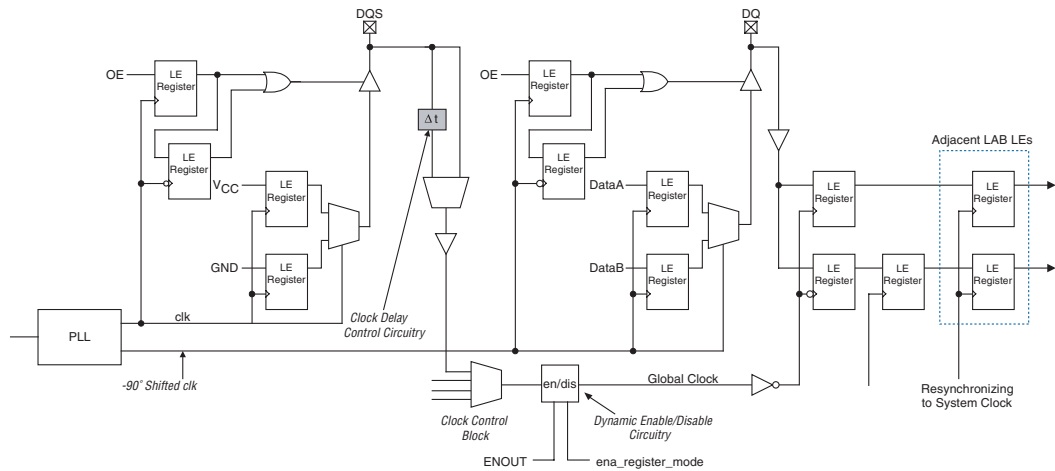

For more information on Cyclone II external memory interfaces, see the *External Memory Interfaces* chapter in Volume 1 of the *Cyclone II Device Handbook*.

Programmable Drive Strength

The output buffer for each Cyclone II device I/O pin has a programmable drive strength control for certain I/O standards. The LVTTTL, LVCMOS, SSTL-2 class I and II, SSTL-18 class I and II, HSTL-18 class I and II, and HSTL-1.5 class I and II standards have several levels of drive strength that you can control. Using minimum settings provides signal slew rate control to reduce system noise and signal overshoot. Table 2-17 shows the possible settings for the I/O standards with drive strength control.

Table 2-17. Programmable Drive Strength (Part 1 of 2) *Note (1)*

I/O Standard	I_{OH}/I_{OL} Current Strength Setting (mA)	
	Top & Bottom I/O Pins	Side I/O Pins
LVTTTL (3.3 V)	4	4
	8	8
	12	12
	16	16
	20	20
	24	24
LVCMOS (3.3 V)	4	4
	8	8
	12	12
	16	
	20	
	24	
LVTTTL/LVCMOS (2.5 V)	4	4
	8	8
	12	
	16	
LVTTTL/LVCMOS (1.8 V)	2	2
	4	4
	6	6
	8	8
	10	10
	12	12

Table 2–17. Programmable Drive Strength (Part 2 of 2) *Note (1)*

I/O Standard	I _{OH} /I _{OL} Current Strength Setting (mA)	
	Top & Bottom I/O Pins	Side I/O Pins
LVCMOS (1.5 V)	2	2
	4	4
	6	6
	8	
SSTL-2 class I	8	8
	12	12
SSTL-2 class II	16	16
	20	
	24	
SSTL-18 class I	6	6
	8	8
	10	10
	12	
SSTL-18 class II	16	
	18	
HSTL-18 class I	8	8
	10	10
	12	12
HSTL-18 class II	16	
	18	
	20	
HSTL-15 class I	8	8
	10	
	12	
HSTL-15 class II	16	

Note to Table 2–17:

- (1) The default current in the Quartus II software is the maximum setting for each I/O standard.

Open-Drain Output

Cyclone II devices provide an optional open-drain (equivalent to an open-collector) output for each I/O pin. This open-drain output enables the device to provide system-level control signals (that is, interrupt and write-enable signals) that can be asserted by any of several devices.

Slew Rate Control

Slew rate control is performed by using programmable output drive strength.

Bus Hold

Each Cyclone II device user I/O pin provides an optional bus-hold feature. The bus-hold circuitry can hold the signal on an I/O pin at its last-driven state. Since the bus-hold feature holds the last-driven state of the pin until the next input signal is present, an external pull-up or pull-down resistor is not necessary to hold a signal level when the bus is tri-stated.

The bus-hold circuitry also pulls undriven pins away from the input threshold voltage where noise can cause unintended high-frequency switching. You can select this feature individually for each I/O pin. The bus-hold output drives no higher than V_{CCIO} to prevent overdriving signals.



If the bus-hold feature is enabled, the device cannot use the programmable pull-up option. Disable the bus-hold feature when the I/O pin is configured for differential signals. Bus hold circuitry is not available on the dedicated clock pins.

The bus-hold circuitry is only active after configuration. When going into user mode, the bus-hold circuit captures the value on the pin present at the end of configuration.

The bus-hold circuitry uses a resistor with a nominal resistance (R_{BH}) of approximately 7 k Ω to pull the signal level to the last-driven state. Refer to the *DC Characteristics & Timing Specifications* chapter in Volume 1 of the *Cyclone II Device Handbook* for the specific sustaining current for each V_{CCIO} voltage level driven through the resistor and overdrive current used to identify the next driven input level.

Programmable Pull-Up Resistor

Each Cyclone II device I/O pin provides an optional programmable pull-up resistor during user mode. If you enable this feature for an I/O pin, the pull-up resistor (typically 25 k Ω) holds the output to the V_{CCIO} level of the output pin's bank.



If the programmable pull-up is enabled, the device cannot use the bus-hold feature. The programmable pull-up resistors are not supported on the dedicated configuration, JTAG, and dedicated clock pins.

Advanced I/O Standard Support

Table 2–18 shows the I/O standards supported by Cyclone II devices and which I/O pins support them.

I/O Standard	Type	V _{CCIO} Level		Top & Bottom I/O Pins		Side I/O Pins		
		Input	Output	CLK, DQS	User I/O Pins	CLK, DQS	PLL_OUT	User I/O Pins
3.3-V LVTTTL and LVCMOS	Single ended	3.3 V / 2.5 V	3.3 V	✓	✓	✓	✓	✓
2.5-V LVTTTL and LVCMOS	Single ended	3.3 V / 2.5 V	2.5 V	✓	✓	✓	✓	✓
1.8-V LVTTTL and LVCMOS	Single ended	1.8 V / 1.5 V	1.8 V	✓	✓	✓	✓	✓
1.5-V LVCMOS	Single ended	1.8 V / 1.5 V	1.5 V	✓	✓	✓	✓	✓
SSTL-2 class I	Voltage referenced	2.5 V	2.5 V	✓	✓	✓	✓	✓
SSTL-2 class II	Voltage referenced	2.5 V	2.5 V	✓	✓	✓	✓	✓
SSTL-18 class I	Voltage referenced	1.8 V	1.8 V	✓	✓	✓	✓	✓
SSTL-18 class II	Voltage referenced	1.8 V	1.8 V	✓	✓	(1)	(1)	(1)
HSTL-18 class I	Voltage referenced	1.8 V	1.8 V	✓	✓	✓	✓	✓
HSTL-18 class II	Voltage referenced	1.8 V	1.8 V	✓	✓	(1)	(1)	(1)
HSTL-15 class I	Voltage referenced	1.5 V	1.5 V	✓	✓	✓	✓	✓
HSTL-15 class II	Voltage referenced	1.5 V	1.5 V	✓	✓	(1)	(1)	(1)
PCI and PCI-X (2)	Single ended	3.3 V	3.3 V			✓	✓	✓
Differential SSTL-2 class I or class II	Pseudo differential (3)	(4)	2.5 V				✓	
		2.5 V	(4)	✓ (5)		✓ (5)		
Differential SSTL-18 class I or class II	Pseudo differential (3)	(4)	1.8 V				✓ (6)	
		1.8 V	(4)	✓ (5)		✓ (5)		

Table 2–18. Cyclone II Supported I/O Standards & Constraints (Part 2 of 2)

I/O Standard	Type	V _{CCIO} Level		Top & Bottom I/O Pins		Side I/O Pins		
		Input	Output	CLK, DQS	User I/O Pins	CLK, DQS	PLL_OUT	User I/O Pins
Differential HSTL-15 class I or class II	Pseudo differential (3)	(4)	1.5 V				✓ (6)	
		1.5 V	(4)	✓ (5)		✓ (5)		
Differential HSTL-18 class I or class II	Pseudo differential (3)	(4)	1.8 V				✓ (6)	
		1.8 V	(4)	✓ (5)		✓ (5)		
LVDS	Differential	2.5 V	2.5 V	✓	✓	✓	✓	✓
RSDS and mini-LVDS (7)	Differential	(4)	2.5 V		✓		✓	✓
LVPECL (8)	Differential	3.3 V/ 2.5 V/ 1.8 V/ 1.5 V	(4)	✓		✓		

Notes to Table 2–18:

- (1) These pins support SSTL-18 class II and 1.8- and 1.5-V HSTL class II inputs.
- (2) PCI-X does not meet the IV curve requirement at the linear region. PCI-clamp diode is not available on top and bottom I/O pins.
- (3) Pseudo-differential HSTL and SSTL outputs use two single-ended outputs with the second output programmed as inverted. Pseudo-differential HSTL and SSTL inputs treat differential inputs as two single-ended HSTL and SSTL inputs and only decode one of them.
- (4) This I/O standard is not supported on these I/O pins.
- (5) This I/O standard is only supported on the dedicated clock pins.
- (6) PLL_OUT does not support differential SSTL-18 class II and differential 1.8 and 1.5-V HSTL class II.
- (7) mini-LVDS and RSDS are only supported on output pins.
- (8) LVPECL is only supported on clock inputs.



For more information on Cyclone II supported I/O standards, see the *Selectable I/O Standards in Cyclone II Devices* chapter in Volume 1 of the *Cyclone II Device Handbook*.

High-Speed Differential Interfaces

Cyclone II devices can transmit and receive data through LVDS signals at a data rate of up to 640 Mbps and 805 Mbps, respectively. For the LVDS transmitter and receiver, the Cyclone II device's input and output pins support serialization and deserialization through internal logic.

The reduced swing differential signaling (RSDS) and mini-LVDS standards are derivatives of the LVDS standard. The RSDS and mini-LVDS I/O standards are similar in electrical characteristics to LVDS, but have a smaller voltage swing and therefore provide increased power benefits and reduced electromagnetic interference (EMI). Cyclone II devices support the RSDS and mini-LVDS I/O standards at data rates up to 311 Mbps at the transmitter.

A subset of pins in each I/O bank (on both rows and columns) support the high-speed I/O interface. The dual-purpose LVDS pins require an external-resistor network at the transmitter channels in addition to 100- Ω termination resistors on receiver channels. These pins do not contain dedicated serialization or deserialization circuitry. Therefore, internal logic performs serialization and deserialization functions.

Cyclone II pin tables list the pins that support the high-speed I/O interface. The number of LVDS channels supported in each device family member is listed in [Table 2–19](#).

Device	Pin Count	Number of LVDS Channels (1)
EP2C5	144	31 (35)
	208	56 (60)
	256	61 (65)
EP2C8	144	29 (33)
	208	53 (57)
	256	75 (79)
EP2C20	240	45 (53)
	256	52 (60)
	484	128 (136)
EP2C35	484	131 (139)
	672	201 (209)
EP2C50	484	119 (127)
	672	189 (197)

Table 2–19. Cyclone II Device LVDS Channels (Part 2 of 2)

Device	Pin Count	Number of LVDS Channels (1)
EP2C70	672	160 (168)
	896	257 (265)

Note to Table 2–19:

- (1) The first number represents the number of bidirectional I/O pins which can be used as inputs or outputs. The number in parenthesis includes dedicated clock input pin pairs which can only be used as inputs.

You can use I/O pins and internal logic to implement a high-speed I/O receiver and transmitter in Cyclone II devices. Cyclone II devices do not contain dedicated serialization or deserialization circuitry. Therefore, shift registers, internal PLLs, and IOEs are used to perform serial-to-parallel conversions on incoming data and parallel-to-serial conversion on outgoing data.

The maximum internal clock frequency for a receiver and for a transmitter is 402.5 MHz. The maximum input data rate of 805 Mbps and the maximum output data rate of 640 Mbps is only achieved when DDIO registers are used. The LVDS standard does not require an input reference voltage, but it does require a 100- Ω termination resistor between the two signals at the input buffer. An external resistor network is required on the transmitter side.



For more information on Cyclone II differential I/O interfaces, see the *High-Speed Differential Interfaces in Cyclone II Devices* chapter in Volume 1 of the *Cyclone II Device Handbook*.

Series On-Chip Termination

On-chip termination helps to prevent reflections and maintain signal integrity. This also minimizes the need for external resistors in high pin count ball grid array (BGA) packages. Cyclone II devices provide I/O driver on-chip impedance matching and on-chip series termination for single-ended outputs and bidirectional pins.

Cyclone II devices support driver impedance matching to the impedance of the transmission line, typically 25 or 50 Ω . When used with the output drivers, on-chip termination sets the output driver impedance to 25 or 50 Ω . Cyclone II devices also support I/O driver series termination ($R_S = 50 \Omega$) for SSTL-2 and SSTL-18. Table 2–20 lists the I/O standards that support impedance matching and series termination.

Table 2–20. I/O Standards Supporting Series Termination *Note (1)*

I/O Standards	Target R_S (Ω)	V_{CCIO} (V)
3.3-V LVTTTL and LVCMOS	25 (2)	3.3
2.5-V LVTTTL and LVCMOS	50 (2)	2.5
1.8-V LVTTTL and LVCMOS	50 (2)	1.8
SSTL-2 class I	50 (2)	2.5
SSTL-18 class I	50 (2)	1.8

Notes to Table 2–20:

- (1) Supported conditions are $V_{CCIO} = V_{CCIO} \pm 50$ mV.
- (2) These R_S values are nominal values. Actual impedance varies across process, voltage, and temperature conditions.



The recommended frequency range of operation is pending silicon characterization.

On-chip series termination can be supported on any I/O bank. V_{CCIO} and V_{REF} must be compatible for all I/O pins in order to enable on-chip series termination in a given I/O bank. I/O standards that support different R_S values can reside in the same I/O bank as long as their V_{CCIO} and V_{REF} are not conflicting.



When using on-chip series termination, programmable drive strength is not available.

Impedance matching is implemented using the capabilities of the output driver and is subject to a certain degree of variation, depending on the process, voltage and temperature. The actual tolerance is pending silicon characterization.

I/O Banks

The I/O pins on Cyclone II devices are grouped together into I/O banks and each bank has a separate power bus. EP2C5 and EP2C8 devices have four I/O banks (see [Figure 2–28](#)), while EP2C20, EP2C35, EP2C50, and EP2C70 devices have eight I/O banks (see [Figure 2–29](#)). Each device I/O pin is associated with one I/O bank. To accommodate voltage-referenced I/O standards, each Cyclone II I/O bank has a VREF bus. Each bank in EP2C5, EP2C8, EP2C20, EP2C35, and EP2C50 devices supports two VREF pins and each bank of EP2C70 supports three VREF pins. When using the VREF pins, each VREF pin must be properly connected to the appropriate voltage level. In the event these pins are not used as VREF pins, they may be used as regular I/O pins.

The top and bottom I/O banks (banks 2 and 4 in EP2C5 and EP2C8 devices and banks 3, 4, 7, and 8 in EP2C20, EP2C35, EP2C50, and EP2C70 devices) support all I/O standards listed in [Table 2–18](#), except the PCI/PCI-X I/O standards. The left and right side I/O banks (banks 1 and 3 in EP2C5 and EP2C8 devices and banks 1, 2, 5, and 6 in EP2C20, EP2C35, EP2C50, and EP2C70 devices) support I/O standards listed in [Table 2–18](#), except SSTL-18 class II, HSTL-18 class II, and HSTL-15 class II I/O standards. See [Table 2–18](#) for a complete list of supported I/O standards.

The top and bottom I/O banks (banks 2 and 4 in EP2C5 and EP2C8 devices and banks 3, 4, 7, and 8 in EP2C20, EP2C35, EP2C50, and EP2C70 devices) support DDR2 memory up to 167 MHz/333 Mbps and QDR memory up to 167 MHz/668 Mbps. The left and right side I/O banks (1 and 3 of EP2C5 and EP2C8 devices and 1, 2, 5, and 6 of EP2C20, EP2C35, EP2C50, and EP2C70 devices) only support SDR and DDR SDRAM interfaces. All the I/O banks of the Cyclone II devices support SDR memory up to 167 MHz/167 Mbps and DDR memory up to 167 MHz/333 Mbps.

Figure 2–28. EP2C5 & EP2C8 I/O Banks Notes (1), (2)

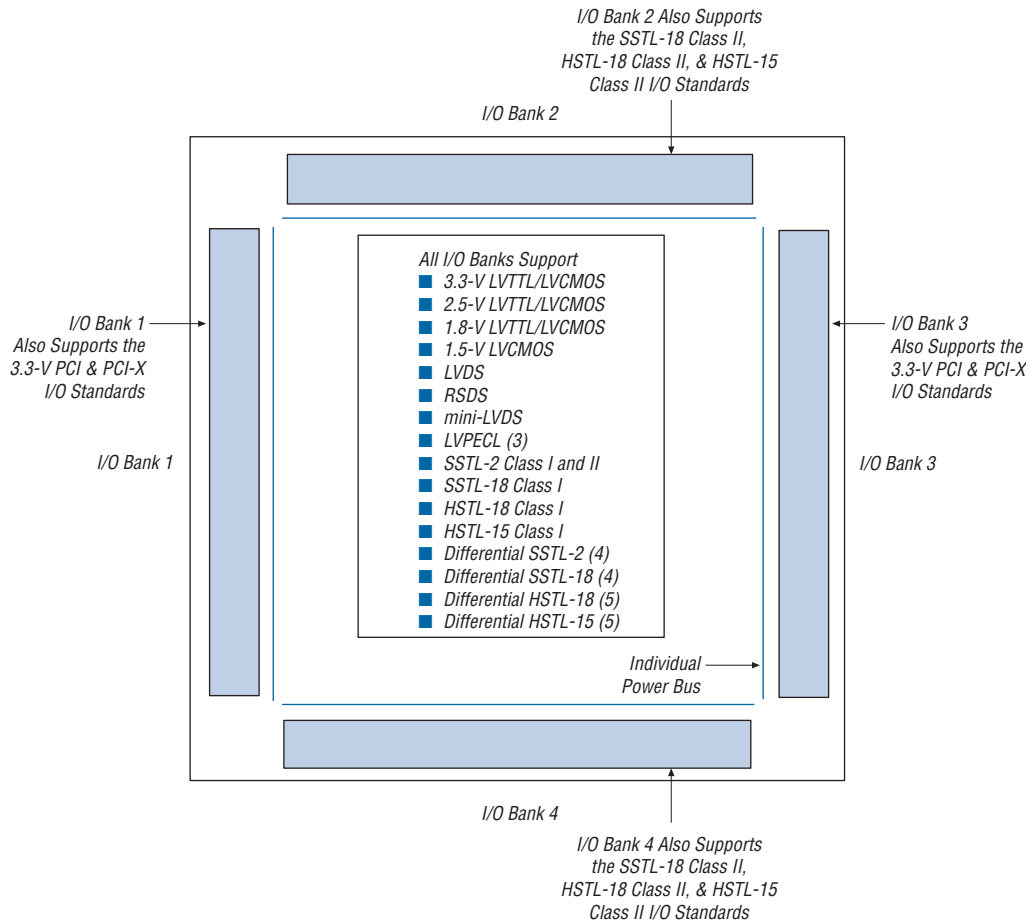

Notes to Figure 2–28:

- (1) This is a top view of the silicon die.
- (2) This is a graphic representation only. Refer to the pin list and the Quartus II software for exact pin locations.
- (3) The LVPECL I/O standard is only supported on clock input pins. This I/O standard is not supported on output pins.
- (4) The differential SSTL-18 and SSTL-2 I/O standards are only supported on clock input pins and PLL output clock pins.
- (5) The differential 1.8-V and 1.5-V HSTL I/O standards are only supported on clock input pins and PLL output clock pins.

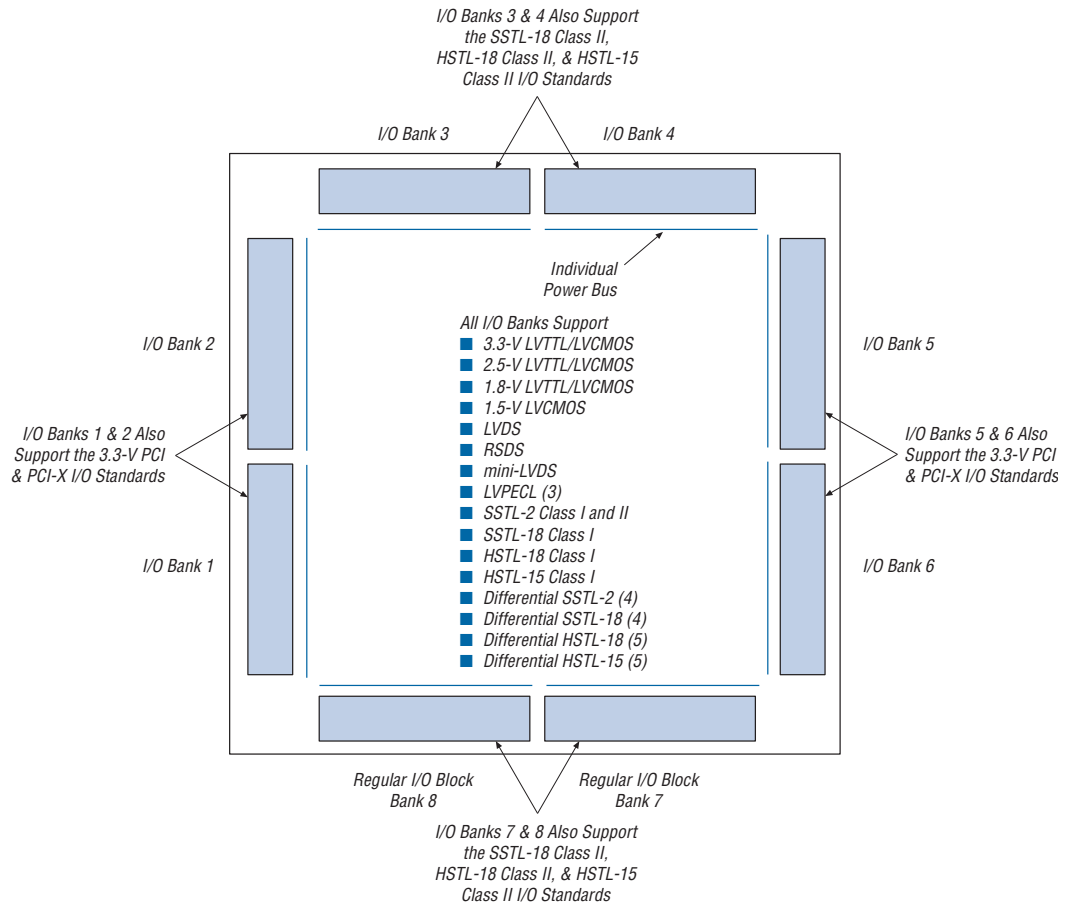
Figure 2–29. EP2C20, EP2C35, EP2C50 & EP2C70 I/O Banks *Notes (1), (2)***Notes to Figure 2–29:**

- (1) This is a top view of the silicon die.
- (2) This is a graphic representation only. Refer to the pin list and the Quartus II software for exact pin locations.
- (3) The LVPECL I/O standard is only supported on clock input pins. This I/O standard is not supported on output pins.
- (4) The differential SSTL-18 and SSTL-2 I/O standards are only supported on clock input pins and PLL output clock pins.
- (5) The differential 1.8-V and 1.5-V HSTL I/O standards are only supported on clock input pins and PLL output clock pins.

Each I/O bank has its own VCCIO pins. A single device can support 1.5-V, 1.8-V, 2.5-V, and 3.3-V interfaces; each individual bank can support a different standard with different I/O voltages. Each bank also has dual-purpose VREF pins to support any one of the voltage-referenced

standards (e.g., SSTL-2) independently. If an I/O bank does not use voltage-referenced standards, the V_{REF} pins are available as user I/O pins.

Each I/O bank can support multiple standards with the same V_{CCIO} for input and output pins. For example, when V_{CCIO} is 3.3-V, a bank can support LVTTTL, LVCMOS, and 3.3-V PCI for inputs and outputs. Voltage-referenced standards can be supported in an I/O bank using any number of single-ended or differential standards as long as they use the same V_{REF} and a compatible V_{CCIO} value.

MultiVolt I/O Interface

The Cyclone II architecture supports the MultiVolt I/O interface feature, which allows Cyclone II devices in all packages to interface with systems of different supply voltages. Cyclone II devices have one set of V_{CC} pins (V_{CCINT}) that power the internal device logic array and input buffers that use the LVPECL, LVDS, HSTL, or SSTL I/O standards. Cyclone II devices also have four or eight sets of V_{CC} pins (V_{CCIO}) that power the I/O output drivers and input buffers that use the LVTTTL, LVCMOS, or PCI I/O standards.

The Cyclone II V_{CCINT} pins must always be connected to a 1.2-V power supply. If the V_{CCINT} level is 1.2 V, then input pins are 1.5-V, 1.8-V, 2.5-V, and 3.3-V tolerant. The V_{CCIO} pins can be connected to either a 1.5-V, 1.8-V, 2.5-V, or 3.3-V power supply, depending on the output requirements. The output levels are compatible with systems of the same voltage as the power supply (i.e., when V_{CCIO} pins are connected to a 1.5-V power supply, the output levels are compatible with 1.5-V systems). When V_{CCIO} pins are connected to a 3.3-V power supply, the output high is 3.3-V and is compatible with 3.3-V systems. Table 2–21 summarizes Cyclone II MultiVolt I/O support.

V_{CCIO} (V)	Input Signal				Output Signal			
	1.5 V	1.8 V	2.5 V	3.3 V	1.5 V	1.8 V	2.5 V	3.3 V
1.5	✓	✓	✓ (2)	✓ (2)	✓			
1.8	✓ (4)	✓	✓ (2)	✓ (2)	✓ (3)	✓		
2.5			✓	✓	✓ (5)	✓ (5)	✓	

V_{CCIO} (V)	Input Signal				Output Signal			
	1.5 V	1.8 V	2.5 V	3.3 V	1.5 V	1.8 V	2.5 V	3.3 V
3.3			✓ (4)	✓	✓ (6)	✓ (6)	✓ (6)	✓

Notes to Table 2–21:

- (1) The PCI clamping diode must be disabled to drive an input with voltages higher than V_{CCIO} .
- (2) When $V_{CCIO} = 1.5\text{-V}$ or 1.8-V and a 2.5-V or 3.3-V input signal feeds an input pin, higher pin leakage current is expected.
- (3) When $V_{CCIO} = 1.8\text{-V}$, a Cyclone II device can drive a 1.5-V device with 1.8-V tolerant inputs.
- (4) When $V_{CCIO} = 3.3\text{-V}$ and a 2.5-V input signal feeds an input pin or when $V_{CCIO} = 1.8\text{-V}$ and a 1.5-V input signal feeds an input pin, the V_{CCIO} supply current will be slightly larger than expected. The reason for this increase is that the input signal level does not drive to the V_{CCIO} rail, which causes the input buffer to not completely shut off.
- (5) When $V_{CCIO} = 2.5\text{-V}$, a Cyclone II device can drive a 1.5-V or 1.8-V device with 2.5-V tolerant inputs.
- (6) When $V_{CCIO} = 3.3\text{-V}$, a Cyclone II device can drive a 1.5-V , 1.8-V , or 2.5-V device with 3.3-V tolerant inputs.

IEEE Std. 1149.1 (JTAG) Boundary Scan Support

All Cyclone™ II devices provide JTAG BST circuitry that complies with the IEEE Std. 1149.1. JTAG boundary-scan testing can be performed either before or after, but not during configuration. Cyclone II devices can also use the JTAG port for configuration with the Quartus® II software or hardware using either Jam Files (.jam) or Jam Byte-Code Files (.jbc).

Cyclone II devices support IOE I/O standard reconfiguration through the JTAG BST chain. The JTAG chain can update the I/O standard for all input and output pins any time before or during user mode through the CONFIG_IO instruction. You can use this capability for JTAG testing before configuration when some of the Cyclone II pins drive or receive from other devices on the board using voltage-referenced standards. Since the Cyclone II device might not be configured before JTAG testing, the I/O pins may not be configured for appropriate electrical standards for chip-to-chip communication. Programming the I/O standards via JTAG allows you to fully test I/O connections to other devices.



For information on I/O reconfiguration, see *MorphIO: An I/O Reconfiguration Solution for Altera Devices White Paper*.

A device operating in JTAG mode uses four required pins: TDI, TDO, TMS, and TCK. The TCK pin has an internal weak pull-down resistor, while the TDI and TMS pins have weak internal pull-up resistors. The TDO output pin and all JTAG input pin voltage is determined by the V_{CCIO} of the bank where it resides. The bank V_{CCIO} selects whether the JTAG inputs are 1.5-, 1.8-, 2.5-, or 3.3-V compatible.

Cyclone II devices also use the JTAG port to monitor the logic operation of the device with the SignalTap® II embedded logic analyzer. Cyclone II devices support the JTAG instructions shown in [Table 3-1](#).

JTAG Instruction	Instruction Code	Description
SAMPLE/PRELOAD	00 0000 0101	Allows a snapshot of signals at the device pins to be captured and examined during normal device operation, and permits an initial data pattern to be output at the device pins. Also used by the SignalTap II embedded logic analyzer.
EXTEST (1)	00 0000 1111	Allows the external circuitry and board-level interconnects to be tested by forcing a test pattern at the output pins and capturing test results at the input pins.
BYPASS	11 1111 1111	Places the 1-bit bypass register between the TDI and TDO pins, which allows the BST data to pass synchronously through selected devices to adjacent devices during normal device operation.
USERCODE	00 0000 0111	Selects the 32-bit USERCODE register and places it between the TDI and TDO pins, allowing the USERCODE to be serially shifted out of TDO.
IDCODE	00 0000 0110	Selects the IDCODE register and places it between TDI and TDO, allowing the IDCODE to be serially shifted out of TDO.
HIGHZ (1)	00 0000 1011	Places the 1-bit bypass register between the TDI and TDO pins, which allows the BST data to pass synchronously through selected devices to adjacent devices during normal device operation, while tri-stating all of the I/O pins.
CLAMP (1)	00 0000 1010	Places the 1-bit bypass register between the TDI and TDO pins, which allows the BST data to pass synchronously through selected devices to adjacent devices during normal device operation while holding I/O pins to a state defined by the data in the boundary-scan register.
ICR instructions		Used when configuring a Cyclone II device via the JTAG port with a USB Blaster™, ByteBlaster™ II, MasterBlaster™ or ByteBlasterMV™ download cable, or when using a Jam File or JBC File via an embedded processor.
PULSE_NCONFIG	00 0000 0001	Emulates pulsing the nCONFIG pin low to trigger reconfiguration even though the physical pin is unaffected.

Table 3–1. Cyclone II JTAG Instructions (Part 2 of 2)

JTAG Instruction	Instruction Code	Description
CONFIG_IO	00 0000 1101	Allows configuration of I/O standards through the JTAG chain for JTAG testing. Can be executed before, after, or during configuration. Stops configuration if executed during configuration. Once issued, the CONFIG_IO instruction holds nSTATUS low to reset the configuration device. nSTATUS is held low until the device is reconfigured.
SignalTap II instructions		Monitors internal device operation with the SignalTap II embedded logic analyzer.

Note to Table 3–1:

- (1) Bus hold and weak pull-up resistor features override the high-impedance state of HIGHZ, CLAMP, and EXTEST.

The Quartus II software has an Auto Usercode feature where you can choose to use the checksum value of a programming file as the JTAG user code. If selected, the checksum is automatically loaded to the USERCODE register. In the Settings dialog box in the Assignments menu, click **Device & Pin Options**, then **General**, and then turn on the **Auto Usercode option**.

The Cyclone II device instruction register length is 10 bits and the USERCODE register length is 32 bits. Tables 3–2 and 3–3 show the boundary-scan register length and device IDCODE information for Cyclone II devices.

Table 3–2. Cyclone II Boundary-Scan Register Length

Device	Boundary-Scan Register Length
EP2C5	498
EP2C8	597
EP2C20	969
EP2C35	1,449
EP2C50	1,374
EP2C70	1,890

Table 3–3. 32-Bit Cyclone II Device IDCODE

Device	IDCODE (32 Bits) (1)			
	Version (4 Bits)	Part Number (16 Bits)	Manufacturer Identity (11 Bits)	LSB (1 Bit) (2)
EP2C5	0000	0010 0000 1011 0001	000 0110 1110	1
EP2C8	0000	0010 0000 1011 0010	000 0110 1110	1
EP2C20	0000	0010 0000 1011 0011	000 0110 1110	1
EP2C35	0000	0010 0000 1011 0100	000 0110 1110	1
EP2C50	0000	0010 0000 1011 0101	000 0110 1110	1
EP2C70	0000	0010 0000 1011 0110	000 0110 1110	1

Notes to Table 3–3:

- (1) The most significant bit (MSB) is on the left.
- (2) The IDCODE's least significant bit (LSB) is always 1.

For more information on the Cyclone II JTAG specifications, refer to the *DC Characteristics & Timing Specifications* chapter in the *Cyclone II Device Handbook, Volume 1*.

SignalTap II Embedded Logic Analyzer

Cyclone II devices support the SignalTap II embedded logic analyzer, which monitors design operation over a period of time through the IEEE Std. 1149.1 (JTAG) circuitry. You can analyze internal logic at speed without bringing internal signals to the I/O pins. This feature is particularly important for advanced packages, such as FineLine BGA® packages, because it can be difficult to add a connection to a pin during the debugging process after a board is designed and manufactured.



For more information on the SignalTap II, see the *Signal Tap* chapter of the *Quartus II Handbook, Volume 3*.

Configuration

The logic, circuitry, and interconnects in the Cyclone II architecture are configured with CMOS SRAM elements. Altera FPGA devices are reconfigurable and every device is tested with a high coverage production test program so you do not have to perform fault testing and can instead focus on simulation and design verification.

Cyclone II devices are configured at system power-up with data stored in an Altera configuration device or provided by a system controller. The Cyclone II device's optimized interface allows the device to act as controller in an active serial configuration scheme with EPCS serial configuration devices. The serial configuration device can be programmed via SRunner, the ByteBlaster II or USB Blaster download cable, the Altera Programming Unit (APU), or third-party programmers.

In addition to EPCS serial configuration devices, Altera offers in-system programmability (ISP)-capable configuration devices that can configure Cyclone II devices via a serial data stream using the Passive serial (PS) configuration mode. The PS interface also enables microprocessors to treat Cyclone II devices as memory and configure them by writing to a virtual memory location, simplifying reconfiguration. After a Cyclone II device has been configured, it can be reconfigured in-circuit by resetting the device and loading new configuration data. Real-time changes can be made during system operation, enabling innovative reconfigurable applications.

Operating Modes

The Cyclone II architecture uses SRAM configuration elements that require configuration data to be loaded each time the circuit powers up. The process of physically loading the SRAM data into the device is called configuration. During initialization, which occurs immediately after configuration, the device resets registers, enables I/O pins, and begins to operate as a logic device. Together, the configuration and initialization processes are called command mode. Normal device operation is called user mode.

SRAM configuration elements allow Cyclone II devices to be reconfigured in-circuit by loading new configuration data into the device. With real-time reconfiguration, the device is forced into command mode with the `nCONFIG` pin. The configuration process loads different configuration data, reinitializes the device, and resumes user-mode operation. You can perform in-field upgrades by distributing new configuration files within the system or remotely.

A built-in weak pull-up resistor pulls all user I/O pins to V_{CCIO} before and during device configuration.

The configuration pins support 1.5-V/1.8-V or 2.5-V/3.3-V I/O standards. The voltage level of the configuration output pins is determined by the V_{CCIO} of the bank where the pins reside. The bank V_{CCIO} selects whether the configuration inputs are 1.5-V, 1.8-V, 2.5-V, or 3.3-V compatible.

Configuration Schemes

You can load the configuration data for a Cyclone II device with one of three configuration schemes (see [Table 3-4](#)), chosen on the basis of the target application. You can use a configuration device, intelligent controller, or the JTAG port to configure a Cyclone II device. A low-cost configuration device can automatically configure a Cyclone II device at system power-up.

Multiple Cyclone II devices can be configured in any of the three configuration schemes by connecting the configuration enable (nCE) and configuration enable output ($nCEO$) pins on each device.

Table 3-4. Data Sources for Configuration

Configuration Scheme	Data Source
Active serial (AS)	Low-cost serial configuration device
Passive serial (PS)	Enhanced or EPC2 configuration device, MasterBlaster, ByteBlasterMV, ByteBlaster II or USB Blaster download cable, or serial data source
JTAG	MasterBlaster, ByteBlasterMV, ByteBlaster II or USB Blaster download cable or a microprocessor with a Jam or JBC file



For more information on configuration, see the *Configuring Cyclone II Devices* chapter of the *Cyclone II Handbook, Volume 2*.

Cyclone II Automated Single Event Upset Detection

Cyclone II devices offer on-chip circuitry for automated checking of single event upset (SEU) detection. Some applications that require the device to operate error free at high elevations or in close proximity to earth's North or South Pole require periodic checks to ensure continued data integrity. The error detection cyclic redundancy code (CRC) feature controlled by the **Device & Pin Options** dialog box in the Quartus II software uses a 32-bit CRC circuit to ensure data reliability and is one of the best options for mitigating SEU.

You can implement the error detection CRC feature with existing circuitry in Cyclone II devices, eliminating the need for external logic. For Cyclone II devices, the CRC is computed by the device during configuration and checked against an automatically computed CRC during normal operation. The `CRC_ERROR` pin reports a soft error when configuration SRAM data is corrupted, triggering device reconfiguration.

Custom-Built Circuitry

Dedicated circuitry in the Cyclone II devices performs error detection automatically. This error detection circuitry in Cyclone II devices constantly checks for errors in the configuration SRAM cells while the device is in user mode. You can monitor one external pin for the error and use it to trigger a re-configuration cycle. You can select the desired time between checks by adjusting a built-in clock divider.

Software Interface

In the Quartus II software version 4.1 and later, you can turn on the automated error detection CRC feature in the Device & Pin Options dialog box. This dialog box allows you to enable the feature and set the internal frequency of the CRC checker between 400 kHz to 80 MHz. This controls the rate that the CRC circuitry verifies the internal configuration SRAM bits in the FPGA device.



For more information on CRC, refer to the *Error Detection Using CRC in Altera FPGAs* Application Note.

Introduction

Cyclone™ II devices offer hot socketing (also known as hot plug-in, hot insertion, or hot swap) and power sequencing support without the use of any external devices. You can insert or remove a Cyclone II board in a system during system operation without causing undesirable effects to the board or to the running system bus.

The hot-socketing feature lessens the board design difficulty when using Cyclone II devices on printed circuit boards (PCBs) that also contain a mixture of 3.3-, 2.5-, 1.8-, and 1.5-V devices. With the Cyclone II hot-socketing feature, you no longer need to ensure a proper power-up sequence for each device on the board.

The Cyclone II hot-socketing feature provides:

- Board or device insertion and removal without external components or board manipulation
- Support for any power-up sequence
- Non-intrusive I/O buffers to system buses during hot insertion

This chapter also discusses the power-on reset (POR) circuitry in Cyclone II devices. The POR circuitry keeps the devices in the reset state until the V_{CC} is within operating range.

Cyclone II Hot-Socketing Specifications

Cyclone II devices offer hot-socketing capability with all three features listed above without any external components or special design requirements. The hot-socketing feature in Cyclone II devices offers the following:

- The device can be driven before power-up without any damage to the device itself.
- I/O pins remain tri-stated during power-up. The device does not drive out before or during power-up, thereby affecting other buses in operation.
- There are no internal current paths from I/O pins to V_{CCIO} or V_{CCINT} power supplies. Signals driven in on I/O pins do not power the V_{CCIO} or V_{CCINT} power buses.

Devices Can Be Driven before Power-Up

You can drive signals into the I/O pins, dedicated input pins, and dedicated clock pins of Cyclone II devices before or during power-up or power-down without damaging the device. Cyclone II devices support any power-up or power-down sequence (V_{CCIO} and V_{CCINT}) to simplify system level design.

I/O Pins Remain Tri-States during Power-Up

A device that does not support hot socketing may interrupt system operation or cause contention by driving out before or during power-up. In a hot-socketing situation, the Cyclone II device's output buffers are turned off during system power-up or power-down. The Cyclone II device also does not drive out until the device is configured and has attained proper operating conditions.

Signal Pins Do Not Have Internal Current Paths to V_{CCIO} or V_{CCINT} Power Supplies

Devices that do not support hot socketing can short power supplies together when powered-up through the device signal pins. This irregular power-up can damage both the driving and driven devices and can disrupt card power-up.

Cyclone II devices do not have a current path from I/O pins, dedicated input pins, or dedicated clock pins to the V_{CCIO} or V_{CCINT} pins before or during power-up. A Cyclone II device may be inserted into (or removed from) a powered-up system board without damaging or interfering with system-board operation. When hot socketing, Cyclone II devices may have a minimal effect on the signal integrity of the backplane.



You can power up or power down the V_{CCIO} and V_{CCINT} pins in any sequence. The power supply ramp rates can range from 100 μ s to 100 ms. Both V_{CC} supplies must power down within 100 ms of each other to prevent I/O pins from driving out. During hot socketing, the I/O pin capacitance is less than 15 pF and the clock pin capacitance is less than 20 pF. Cyclone II devices meet the following hot-socketing specification.

The hot-socketing DC specification is: $| I_{IOPIN} | < 300 \mu\text{A}$

The hot-socketing AC specification is: $| I_{IOPIN} | < 8 \text{ mA}$ or
 $| I_{IOPIN} | > 8 \text{ mA}$ for 10 ns or less

I_{IOPIN} is the current at any user I/O pin on the device. The AC specification has two requirements. The peak current during power-up or power-down is < 8 mA. The peak current can exceed 8 mA for 10 ns or less.

A possible concern for semiconductor devices in general regarding hot socketing is the potential for latch-up. Latch-up can occur when electrical subsystems are hot socketed into an active system. During hot socketing, the signal pins may be connected and driven by the active system before the power supply can provide current to the device's V_{CC} and ground planes. This condition can lead to latch-up and cause a low-impedance path from V_{CC} to ground within the device. As a result, the device extends a large amount of current, possibly causing electrical damage.

Altera has ensured by design of the I/O buffers and hot-socketing circuitry, that Cyclone II devices are immune to latch-up during hot socketing.

Hot-Socketing Feature Implementation in Cyclone II Devices

The hot-socketing feature turns off the output buffer during power up (either V_{CCINT} or V_{CCIO} supplies) or power down. The hot-socket circuit generates an internal `HOTSCKT` signal when either V_{CCINT} or V_{CCIO} is below the threshold voltage. Designs cannot use the `HOTSCKT` signal for other purposes. The `HOTSCKT` signal cuts off the output buffer to ensure that no DC current (except for weak pull-up leakage current) leaks through the pin. When V_{CC} ramps up slowly, V_{CC} is still relatively low even after the internal POR signal (not available to the FPGA fabric used by customer designs) is released and the configuration is finished. The `CONF_DONE`, `nCEO`, and `nSTATUS` pins fail to respond, as the output buffer cannot drive out because the hot-socketing circuitry keeps the I/O pins tristated at this low V_{CC} voltage. Therefore, the hot-socketing circuit has been removed on these configuration output or bidirectional pins to ensure that they are able to operate during configuration. These pins are expected to drive out during power-up and power-down sequences.

Each I/O pin has the circuitry shown in [Figure 4-1](#).

Figure 4–1. Hot-Socketing Circuit Block Diagram for Cyclone II Devices

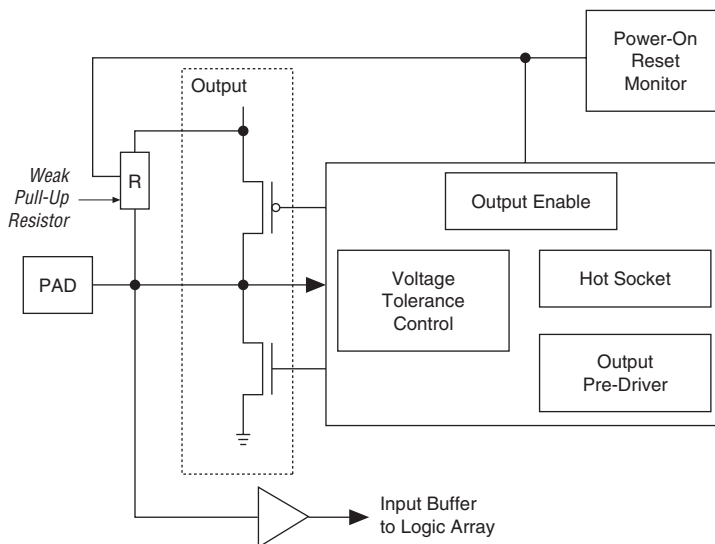

The POR circuit monitors V_{CCINT} voltage level and keeps I/O pins tri-stated until the device is in user mode. The weak pull-up resistor (R) from the I/O pin to V_{CCIO} keeps the I/O pins from floating. The voltage tolerance control circuit permits the I/O pins to be driven by 3.3 V before V_{CCIO} and/or V_{CCINT} are powered, and it prevents the I/O pins from driving out when the device is not in user mode. The hot socket circuit prevents I/O pins from internally powering V_{CCIO} and V_{CCINT} when driven by external signals before the device is powered.



For more information, see the *DC Characteristics & Timing Specifications* chapter in Volume 1 of the *Cyclone II Device Handbook* for the value of the internal weak pull-up resistors.

Figure 4–2 shows a transistor level cross section of the Cyclone II device I/O buffers. This design ensures that the output buffers do not drive when V_{CCIO} is powered before V_{CCINT} or if the I/O pad voltage is higher than V_{CCIO} . This also applies for sudden voltage spikes during hot socketing. There is no current path from signal I/O pins to V_{CCINT} or V_{CCIO} during hot socketing. The V_{PAD} leakage current charges the voltage tolerance control circuit capacitance.

Figure 4–2. Transistor Level Diagram of FPGA Device I/O Buffers

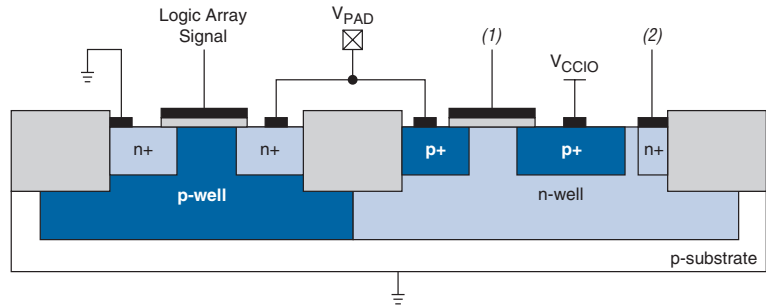

Note to Figure 4–2:

- (1) This is the logic array signal or the larger of either the V_{CCIO} or V_{PAD} signal.
- (2) This is the larger of either the V_{CCIO} or V_{PAD} signal.

Power-On Reset Circuitry

Cyclone II devices have a POR circuit to keep the whole device system in reset state until the power supply voltage levels have stabilized during power-up. The POR circuit monitors the V_{CCINT} and V_{CCIO} voltage levels and tri-states all the user I/O pins while V_{CC} is ramping up until normal user levels are reached. The POR circuitry also ensures that the V_{CCIO} level of the two I/O banks that contains configuration pins (I/O banks 1 and 3 for EP2C5 and EP2C8, I/O banks 2 and 6 for EP2C20, EP2C35, EP2C50, and EP2C70) as well as the logic array V_{CCINT} voltage reach an acceptable level before configuration is triggered. After the Cyclone II device enters user mode, the POR circuit continues to monitor the V_{CCINT} voltage level so that a brown-out condition during user mode can be detected. If there is a V_{CCINT} voltage sag below the POR trip point at ~600 to 700 mV during user mode, the POR circuit resets the device. If there is a V_{CCIO} voltage sag during user mode, the POR circuit does not reset the device.

When power is applied to a Cyclone II device, a POR event occurs if V_{CC} reaches the recommended operating range within a certain period of time (specified as a maximum V_{CC} rise time). The maximum V_{CC} rise time for Cyclone II devices is 100 ms. The minimum POR time is 100 ms for Cyclone II devices. However, you can extend initialization time by asserting the $nSTATUS$ pin using an external component.

Conclusion

Cyclone II devices are hot socketable and support all power-up and power-down sequences with the one requirement that V_{CCIO} and V_{CCINT} be powered up and down within 100 ms of each other to keep the I/O pins from driving out. Cyclone II devices do not require any external devices for hot socketing and power sequencing.

Operating Conditions

Cyclone™ II devices are offered in commercial, industrial, and extended temperature grades. Commercial devices are offered in -6 (fastest), -7, -8 speed grades.

All parameter limits are representative of worst-case supply voltage and junction temperature conditions. Unless otherwise noted, the parameter values in this chapter apply to all Cyclone II devices. AC and DC characteristics are specified using the same numbers for both commercial and industrial grades. All parameters representing voltages are measured with respect to ground.

Tables 5-1 through 5-4 provide information on absolute maximum ratings.

Table 5-1. Cyclone II Device Absolute Maximum Ratings *Notes (1), (2)*

Symbol	Parameter	Conditions	Minimum	Maximum	Unit
V _{CCINT}	Supply voltage	With respect to ground	-0.5	1.8	V
V _{CCIO}	Output supply voltage		-0.5	4.6	V
V _{IN}	DC input voltage (3)		-0.5	4.6	V
I _{OUT}	DC output current, per pin		-25	40	mA
T _{STG}	Storage temperature	No bias	-65	150	°C
T _J	Junction temperature	BGA packages under bias		125	°C

Notes to Table 5-1:

- (1) Conditions beyond those listed in this table cause permanent damage to a device. These are stress ratings only. Functional operation at these levels or any other conditions beyond those specified in this chapter is not implied. Additionally, device operation at the absolute maximum ratings for extended periods of time may have adverse effects on the device reliability.
- (2) See the *Operating Requirements for Altera Devices Data Sheet* for more information.
- (3) During transitions, the inputs may over shoot to the voltage shown in Table 5-4 based upon the input duty cycle. The DC case is equivalent to 100% duty cycle. During transition, the inputs may undershoot to -2.0 V for input currents less than 100 mA and periods shorter than 20 ns.

Table 5–2 specifies the recommended operating conditions for Cyclone II devices. It shows the allowed voltage ranges for V_{CCINT} , V_{CCIO} , and the operating junction temperature (T_J). The LVTTTL and LVCMOS inputs are powered by V_{CCIO} only. The LVPECL input buffers on dedicated clock pins are powered by V_{CCINT} . The SSTL, HSTL, LVDS input buffers are powered by both V_{CCINT} and V_{CCIO} .

Symbol	Parameter	Conditions	Minimum	Maximum	Unit
V_{CCINT}	Supply voltage for internal logic and input buffers	(1)	1.15	1.25	V
V_{CCIO} (2)	Supply voltage for output buffers, 3.3-V operation	(1)	3.135 (3.00)	3.465 (3.60) (3)	V
	Supply voltage for output buffers, 2.5-V operation	(1)	2.375	2.625	V
	Supply voltage for output buffers, 1.8-V operation	(1)	1.71	1.89	V
	Supply voltage for output buffers, 1.5-V operation	(1)	1.425	1.575	V
T_J	Operating junction temperature	For commercial use	0	85	°C
		For industrial use	–40	100	°C
		For extended temperature use	–40	125	°C

Notes to Table 5–2:

- (1) The maximum V_{CC} (both V_{CCIO} and V_{CCINT}) rise time is 100 ms, and V_{CC} must rise monotonically.
- (2) The V_{CCIO} range given here spans the lowest and highest operating voltages of all supported I/O standards. The recommended V_{CCIO} range specific to each of the single-ended I/O standards is given in Table 5–6, and those specific to the differential standards is given in Table 5–8.
- (3) The minimum and maximum values of 3.0 V and 3.6 V, respectively, for V_{CCIO} only applies to the PCI and PCI-X I/O standards. See Table 5–6 for the voltage range of other I/O standards.

Table 5–3. DC Characteristics for User I/O, Dual-Purpose & Dedicated Pins

Symbol	Parameter	Conditions	Minimum	Typical	Maximum	Unit	
V_{IN}	Input voltage	(1), (2)	–0.5		4.0	V	
I_I	Input pin leakage current	$V_I = V_{CCIOmax}$ to 0 V (3)	–10		10	μ A	
V_{OUT}	Output voltage		0		V_{CCIO}	V	
I_{OZ}	Tri-stated I/O pin leakage current	$V_O = V_{CCIOmax}$ to 0 V (3)	–10		10	μ A	
I_{CCINT0}	V_{CCINT} supply current (standby)	$V_I =$ ground, no load, no toggling inputs $T_J = 25^\circ$ C Nominal V_{CCINT}	EP2C5		0.010	(4)	A
			EP2C8		0.017	(4)	A
			EP2C20		0.037	(4)	A
			EP2C35		0.066	(4)	A
			EP2C50		0.101	(4)	A
			EP2C70		0.141	(4)	A
I_{CCIO0}	V_{CCIO} supply current (standby)	$V_I =$ ground, no load, no toggling inputs $T_J = 25^\circ$ C $V_{CCIO} = 2.5$ V	EP2C5		0.7	(4)	mA
			EP2C8		0.8	(4)	mA
			EP2C20		0.9	(4)	mA
			EP2C35		1.3	(4)	mA
			EP2C50		1.3	(4)	mA
			EP2C70		1.7	(4)	mA
R_{CONF}	Value of I/O pin pull-up resistor before and during configuration	$V_{CCIO} = 3.3$ V $\pm 10\%$ (5)	10	25	50	k Ω	
		$V_{CCIO} = 2.5$ V $\pm 5\%$ (5)	15	35	60	k Ω	
		$V_{CCIO} = 1.8$ V $\pm 5\%$ (5)	30	65	120	k Ω	
		$V_{CCIO} = 1.5$ V $\pm 5\%$ (5)	40	85	140	k Ω	

Notes to Table 5–3:

- (1) All pins, including dedicated inputs, clock, I/O, and JTAG pins, may be driven before V_{CCINT} and V_{CCIO} are powered.
- (2) The minimum DC input is –0.5 V. During transitions, the inputs may undershoot to –2.0 V or overshoot to the voltages shown in Table 5–4, based on input duty cycle for input currents less than 100 mA. The overshoot is dependent upon duty cycle of the signal. The DC case is equivalent to 100% duty cycle.
- (3) This value is specified for normal device operation. The value may vary during power-up. This applies for all V_{CCIO} settings (3.3, 2.5, 1.8, and 1.5 V).
- (4) Maximum values depend on the actual T_J and design utilization. See the Excel-based PowerPlay Early Power Estimator (www.altera.com) or the Quartus II PowerPlay Power Analyzer feature for maximum values. See the section “Power Consumption” on page 5–13 for more information.
- (5) Pin pull-up resistance values lower if an external source drives the pin higher than V_{CCIO} .

Table 5-4 shows the maximum V_{IN} overshoot voltage and the dependency on the duty cycle of the input signal. See Table 5-3 for more information.

Maximum V_{IN} (V)	Input Signal Duty Cycle
4.0	100% (DC)
4.1	90%
4.2	50%
4.3	30%
4.4	17%
4.5	10%

Single-Ended I/O Standards

Tables 5–6 and 5–7 provide operating condition information when using single-ended I/O standards with Cyclone II devices. Table 5–5 provides descriptions for the voltage and current symbols used in Tables 5–6 and 5–7.

Table 5–5. Voltage & Current Symbol Definitions

Symbol	Definition
V_{CCIO}	Supply voltage for single-ended inputs and for output drivers
V_{REF}	Reference voltage for setting the input switching threshold
V_{IL}	Input voltage that indicates a low logic level
V_{IH}	Input voltage that indicates a high logic level
V_{OL}	Output voltage that indicates a low logic level
V_{OH}	Output voltage that indicates a high logic level
I_{OL}	Output current condition under which V_{OL} is tested
I_{OH}	Output current condition under which V_{OH} is tested
V_{TT}	Voltage applied to a resistor termination as specified by HSTL and SSTL standards

Table 5–6. Recommended Operating Conditions for User I/O Pins Using Single-Ended I/O Standards (Part 1 of 2) *Note (1)*

I/O Standard	V_{CCIO} (V)			V_{REF} (V)			V_{IL} (V)	V_{IH} (V)
	Min	Typ	Max	Min	Typ	Max	Max	Min
3.3-V LVTTTL and LVCMOS	3.135	3.3	3.465				0.8	1.7
2.5-V LVTTTL and LVCMOS	2.375	2.5	2.625				0.7	1.7
1.8-V LVTTTL and LVCMOS	1.710	1.8	1.890				$0.35 \times V_{CCIO}$	$0.65 \times V_{CCIO}$
1.5-V LVCMOS	1.425	1.5	1.575				$0.35 \times V_{CCIO}$	$0.65 \times V_{CCIO}$
PCI and PCI-X	3.000	3.3	3.600				$0.3 \times V_{CCIO}$	$0.5 \times V_{CCIO}$
SSTL-2 class I	2.375	2.5	2.625	1.19	1.25	1.31	$V_{REF} - 0.18$ (DC) $V_{REF} - 0.35$ (AC)	$V_{REF} + 0.18$ (DC) $V_{REF} + 0.35$ (AC)
SSTL-2 class II	2.375	2.5	2.625	1.19	1.25	1.31	$V_{REF} - 0.18$ (DC) $V_{REF} - 0.35$ (AC)	$V_{REF} + 0.18$ (DC) $V_{REF} + 0.35$ (AC)

Table 5–6. Recommended Operating Conditions for User I/O Pins Using Single-Ended I/O Standards (Part 2 of 2) *Note (1)*

I/O Standard	V_{CCIO} (V)			V_{REF} (V)			V_{IL} (V)	V_{IH} (V)
	Min	Typ	Max	Min	Typ	Max	Max	Min
SSTL-18 class I	1.7	1.8	1.9	0.833	0.9	0.969	$V_{REF} - 0.125$ (DC) $V_{REF} - 0.25$ (AC)	$V_{REF} + 0.125$ (DC) $V_{REF} + 0.25$ (AC)
SSTL-18 class II	1.7	1.8	1.9	0.833	0.9	0.969	$V_{REF} - 0.125$ (DC) $V_{REF} - 0.25$ (AC)	$V_{REF} + 0.125$ (DC) $V_{REF} + 0.25$ (AC)
1.8-V HSTL class I	1.71	1.8	1.89	0.85	0.9	0.95	$V_{REF} - 0.1$ (DC) $V_{REF} - 0.2$ (AC)	$V_{REF} + 0.1$ (DC) $V_{REF} + 0.2$ (AC)
1.8-V HSTL class II	1.71	1.8	1.89	0.85	0.9	0.95	$V_{REF} - 0.1$ (DC) $V_{REF} - 0.2$ (AC)	$V_{REF} + 0.1$ (DC) $V_{REF} + 0.2$ (AC)
1.5-V HSTL class I	1.425	1.5	1.575	0.71	0.75	0.79	$V_{REF} - 0.1$ (DC) $V_{REF} - 0.2$ (AC)	$V_{REF} + 0.1$ (DC) $V_{REF} + 0.2$ (AC)
1.5-V HSTL class II	1.425	1.5	1.575	0.71	0.75	0.79	$V_{REF} - 0.1$ (DC) $V_{REF} - 0.2$ (AC)	$V_{REF} + 0.1$ (DC) $V_{REF} + 0.2$ (AC)

Note to Table 5–6:

(1) Nominal values (Nom) are for $T_A = 25^\circ\text{C}$, $V_{CCINT} = 1.2\text{ V}$, and $V_{CCIO} = 1.5, 1.8, 2.5,$ and 3.3 V .

Table 5–7. DC Characteristics of User I/O Pins Using Single-Ended Standards (Part 1 of 2) *Notes (1), (2)*

I/O Standard	Test Conditions		Voltage Thresholds	
	I_{OL} (mA)	I_{OH} (mA)	Maximum V_{OL} (V)	Minimum V_{OH} (V)
3.3-V LVTTTL	4	–4	0.45	2.4
3.3-V LVCMOS	0.1	–0.1	0.2	$V_{CCIO} - 0.2$
2.5-V LVTTTL and LVCMOS	1	–1	0.4	2.0
1.8-V LVTTTL and LVCMOS	2	–2	0.45	$V_{CCIO} - 0.45$
1.5-V LVTTTL and LVCMOS	2	–2	$0.25 \times V_{CCIO}$	$0.75 \times V_{CCIO}$
PCI and PCI-X	1.5	–0.5	$0.1 \times V_{CCIO}$	$0.9 \times V_{CCIO}$
SSTL-2 class I	8.1	–8.1	$V_{TT} - 0.57$	$V_{TT} + 0.57$
SSTL-2 class II	16.4	–16.4	$V_{TT} - 0.76$	$V_{TT} + 0.76$
SSTL-18 class I	6.7	–6.7	$V_{TT} - 0.475$	$V_{TT} + 0.475$
SSTL-18 class II	13.4	–13.4	0.28	$V_{CCIO} - 0.28$

Table 5–7. DC Characteristics of User I/O Pins Using Single-Ended Standards (Part 2 of 2)*Notes (1), (2)*

I/O Standard	Test Conditions		Voltage Thresholds	
	I_{OL} (mA)	I_{OH} (mA)	Maximum V_{OL} (V)	Minimum V_{OH} (V)
1.8-V HSTL class I	8	–8	0.4	$V_{CCIO} - 0.4$
1.8-V HSTL class II	16	–16	0.4	$V_{CCIO} - 0.4$
1.5-V HSTL class I	8	–8	0.4	$V_{CCIO} - 0.4$
1.5V HSTL class II	16	–16	0.4	$V_{CCIO} - 0.4$

Note to Table 5–7:

- (1) The values in this table are based on the conditions listed in Tables 5–2 and 5–6.
- (2) This specification is supported across all the programmable drive settings available as shown in the *Cyclone II Architecture* chapter of the *Cyclone II Device Handbook*.

Differential I/O Standards

The RSDS and mini-LVDS I/O standards are only supported on output pins. The LVDS I/O standard is supported on both receiver input pins and transmitter output pins.



For more information on how these differential I/O standards are implemented, see the *High-Speed Differential Interfaces in Cyclone II Devices* chapter in Volume 1 of the *Cyclone II Device Handbook*.

Figure 5–1 shows the receiver input waveforms for all differential I/O standards (LVDS, LVPECL, differential 1.5-V HSTL class I and II, differential 1.8-V HSTL class I and II, differential SSTL-2 class I and II, and differential SSTL-18 class I and II).

Figure 5–1. Receiver Input Waveforms for Differential I/O Standards

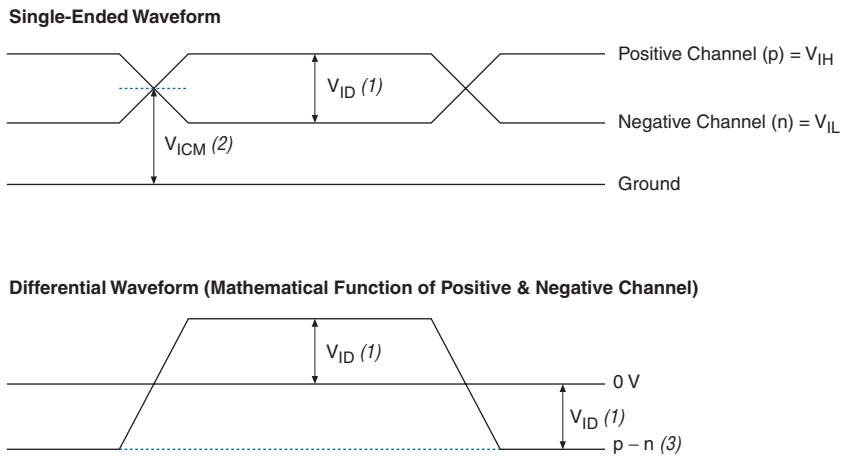

Notes to Figure 5–1:

- (1) V_{ID} is the differential input voltage. $V_{ID} = |p - n|$.
- (2) V_{ICM} is the input common mode voltage. $V_{ICM} = (p + n)/2$.
- (3) The $p - n$ waveform is a function of the positive channel (p) and the negative channel (n).

Table 5–8 shows the recommended operating conditions for user I/O pins with differential I/O standards.

Table 5–8. Recommended Operating Conditions for User I/O Pins Using Differential Signal I/O Standards

I/O Standard	V _{CCIO} (V)			V _{ID} (V) (1)			V _{ICM} (V)			V _{IL} (V)		V _{IH} (V)	
	Min	Typ	Max	Min	Typ	Max	Min	Typ	Max	Min	Max	Min	Max
LVDS	2.375	2.5	2.625	0.1		0.65	0.1		2.0				
Mini-LVDS (2)	2.375	2.5	2.625										
RSDS (2)	2.375	2.5	2.625										
LVPECL (3)	3.135	3.3	3.465	0.1	0.6	0.95				0	2.2	2.1	2.88
Differential 1.5-V HSTL class I and II (4)	1.425	1.5	1.575	0.2		V _{CCIO} + 0.6	0.68		0.9		V _{REF} - 0.20	V _{REF} + 0.20	
Differential 1.8-V HSTL class I and II (4)	1.71	1.8	1.89								V _{REF} - 0.20	V _{REF} + 0.20	
Differential SSTL-2 class I and II (5)	2.375	2.5	2.625	0.36		V _{CCIO} + 0.6	0.5 × V _{CCIO} - 0.2	0.5 × V _{CCIO}	0.5 × V _{CCIO} + 0.2		V _{REF} - 0.35	V _{REF} + 0.35	
Differential SSTL-18 class I and II (5)	1.7	1.8	1.9	0.25		V _{CCIO} + 0.6	0.5 × V _{CCIO} - 0.2	0.5 × V _{CCIO}	0.5 × V _{CCIO} + 0.2		V _{REF} - 0.25	V _{REF} + 0.25	

Notes to Table 5–8:

- (1) Refer to the *High-Speed Differential Interfaces in Cyclone II Devices* chapter in Volume 1 of the *Cyclone II Device Handbook* for measurement conditions on V_{ID}.
- (2) The RSDS and mini-LVDS I/O standards are only supported on output pins.
- (3) The LVPECL I/O standard is only supported on clock input pins. This I/O standard is not supported on output pins.
- (4) The differential 1.8-V and 1.5-V HSTL I/O standards are only supported on clock input pins and PLL output clock pins.
- (5) The differential SSTL-18 and SSTL-2 I/O standards are only supported on clock input pins and PLL output clock pins.

Figure 5–2 shows the transmitter output waveforms for all supported differential output standards (LVDS, mini-LVDS, RSDS, differential 1.5-V HSTL class I and II, differential 1.8-V HSTL class I and II, differential SSTL-2 class I and II, and differential SSTL-18 class I and II).

Figure 5–2. Transmitter Output Waveforms for Differential I/O Standards

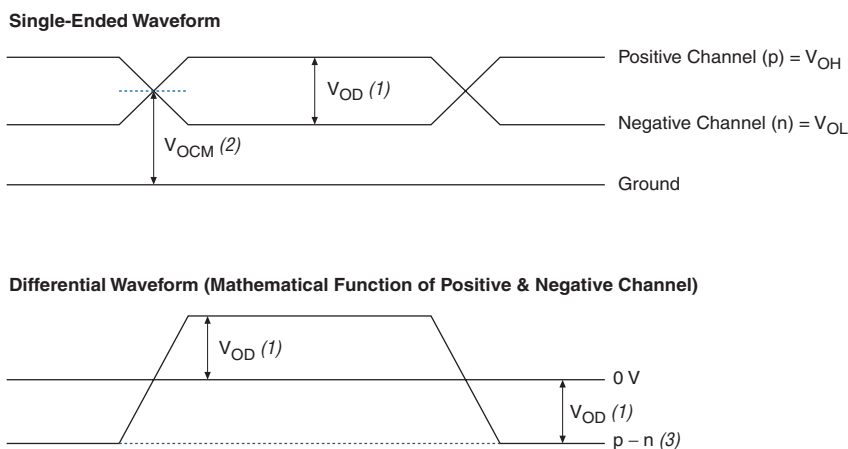

Notes to **Figures 5–1 & 5–2:**

- (1) V_{OD} is the output differential voltage. $V_{OD} = |p - n|$.
- (2) V_{OCM} is the output common mode voltage. $V_{OCM} = (p + n)/2$.
- (3) The $p - n$ waveform is a function of the positive channel (p) and the negative channel (n).

Table 5–9 shows the DC characteristics for user I/O pins with differential I/O standards.

I/O Standard	V_{OD} (mV)			ΔV_{OD} (mV)		V_{OCM} (V)			V_{OH} (V)		V_{OL} (V)	
	Min	Typ	Max	Min	Max	Min	Typ	Max	Min	Max	Min	Max
LVDS	250		600		50	1.125	1.25	1.375				
mini-LVDS (2)	300		600		50	1.125	1.25	1.375				
RSDS (2)	100		600			1.125	1.25	1.375				
Differential 1.5-V HSTL class I and II (3)									$V_{CCIO} - 0.4$			0.4
Differential 1.8-V HSTL class I and II (3)									$V_{CCIO} - 0.4$			0.4
Differential SSTL-2 class I (4)									$V_{TT} + 0.57$			$V_{TT} - 0.57$

Table 5–9. DC Characteristics for User I/O Pins Using Differential I/O Standards (Part 2 of 2) *Note (1)*

I/O Standard	V _{OD} (mV)			ΔV _{OD} (mV)		V _{OCM} (V)			V _{OH} (V)		V _{OL} (V)	
	Min	Typ	Max	Min	Max	Min	Typ	Max	Min	Max	Min	Max
Differential SSTL-2 class II (4)									V _{TT} + 0.76			V _{TT} – 0.76
Differential SSTL-18 class I (4)						0.5 × V _{CCIO} – 0.125	0.5 × V _{CCIO}	0.5 × V _{CCIO} + 0.125	V _{TT} + 0.475			V _{TT} – 0.475
Differential SSTL-18 class II (4)						0.5 × V _{CCIO} – 0.125	0.5 × V _{CCIO}	0.5 × V _{CCIO} + 0.125	V _{CCIO} – 0.28			0.28

Notes to Table 5–9:

- (1) The LVPECL I/O standard is only supported on clock input pins. This I/O standard is not supported on output pins.
- (2) The RSDS and mini-LVDS I/O standards are only supported on output pins.
- (3) The differential 1.8-V HSTL and differential 1.5-V HSTL I/O standards are only supported on clock input pins and PLL output clock pins.
- (4) The differential SSTL-18 and SSTL-2 I/O standards are only supported on clock input pins and PLL output clock pins.

DC Characteristics for Different Pin Types

Table 5–10 shows which types of pins that support bus hold circuitry.

Table 5–10. Bus Hold Support

Pin Type	Bus Hold
I/O pins using single-ended I/O standards	Yes
I/O pins using differential I/O standards	No
Dedicated clock pins	No
JTAG	No
Configuration pins	No

Table 5–11 specifies the bus hold parameters for general I/O pins.

Parameter	Conditions	V_{CCIO} Level						Unit
		1.8 V		2.5 V		3.3 V		
		Min	Max	Min	Max	Min	Max	
Bus-hold low, sustaining current	$V_{IN} > V_{IL}(\text{maximum})$	30		50		70		μA
Bus-hold high, sustaining current	$V_{IN} < V_{IL}(\text{minimum})$	–30		–50		–70		μA
Bus-hold low, overdrive current	$0\text{ V} < V_{IN} < V_{CCIO}$		200		300		500	μA
Bus-hold high, overdrive current	$0\text{ V} < V_{IN} < V_{CCIO}$		–200		–300		–500	μA
Bus-hold trip point (2)		0.68	1.07	0.7	1.7	0.8	2.0	V

Notes to Table 5–11:

- (1) There is no specification for bus-hold at $V_{CCIO} = 1.5\text{ V}$ for the HSTL I/O standard.
 (2) The bus-hold trip points are based on calculated input voltages from the JEDEC standard.

On-Chip Termination Specifications

Table 5–12 defines the specifications for internal termination resistance tolerance when using series or differential on-chip termination.

Symbol	Description	Conditions	Resistance Tolerance			Unit
			Commercial Max	Industrial Max	Extended Temp Max	
$25\text{-}\Omega R_S$	Internal series termination without calibration (25- Ω setting)	$V_{CCIO} = 3.3\text{V}$	± 30	± 30	± 40	%
$50\text{-}\Omega R_S$	Internal series termination without calibration (50- Ω setting)	$V_{CCIO} = 2.5\text{V}$	± 30	± 30	± 40	%
$50\text{-}\Omega R_S$	Internal series termination without calibration (50- Ω setting)	$V_{CCIO} = 1.8\text{V}$	± 30 (1)	± 30 (1)	± 50	%

Notes for Table 5–12:

- (1) For commercial and industrial –8 devices, the tolerance is $\pm 40\%$.

Table 5–13 shows the Cyclone II device pin capacitance for different I/O pin types.

Symbol	Parameter	Typical	Unit
C_{IO}	Input capacitance for user I/O pin	6	pF
C_{LVDS}	Input capacitance for dual-purpose LVDS/user I/O pin	6	pF
C_{VREF}	Input capacitance for dual-purpose VREF and user I/O pin.	21	pF
C_{CLK}	Input capacitance for clock pin.	5	pF

Notes to Table 5–13:

- (1) Capacitance is sample-tested only. Capacitance is measured using time-domain reflectometry (TDR). Measurement accuracy is within ± 0.5 pF.

Power Consumption

You can calculate the power usage for your design using the PowerPlay Early Power Estimator and the PowerPlay Power Analyzer feature in the Quartus® II software.

The interactive PowerPlay Early Power Estimator is typically used during the early stages of FPGA design, prior to finalizing the project, in order to get a magnitude estimate of the device power. The Quartus II software PowerPlay Power Analyzer feature is typically used during the later stages of FPGA design. The PowerPlay Power Analyzer also allows you to apply test vectors against your design for more accurate power consumption modeling.

In both cases, only use these calculations as an estimation of power, not as a specification. For more information on PowerPlay tools, refer to the *PowerPlay Early Power Estimator User Guide* and the *PowerPlay Early Power Estimator* and *PowerPlay Power Analyzer* chapters in volume 3 of the *Quartus II Handbook*.



You can obtain the Excel-based PowerPlay Early Power Estimator at www.altera.com. See Table 5–3 on page 5–3 for typical I_{CC} standby specifications.

The power-up current required by Cyclone II devices does not exceed the maximum static current. The rate at which the current increases is a function of the system power supply. The exact amount of current

consumed varies according to the process, temperature, and power ramp rate. The duration of the I_{CCINT} power-up requirement depends on the V_{CCINT} voltage supply rise time.

You should select power supplies and regulators that can supply the amount of current required when designing with Cyclone II devices.

Altera recommends using the Cyclone II PowerPlay Early Power Estimator to estimate the user-mode I_{CCINT} consumption and then select power supplies or regulators based on the values obtained.

Timing Specifications

The DirectDrive™ technology and MultiTrack™ interconnect ensure predictable performance, accurate simulation, and accurate timing analysis across all Cyclone II device densities and speed grades. This section describes and specifies the performance, internal, external, high-speed I/O, JTAG, and PLL timing specifications.

This section shows the timing models for Cyclone II devices. Commercial devices meet this timing over the commercial temperature range. Industrial devices meet this timing over the industrial temperature range. All specifications are representative of worst-case supply voltage and junction temperature conditions.



The timing numbers listed in the tables of this section are extracted from the Quartus® II software version 5.0 SP1.

Preliminary & Final Timing Specifications

Timing models can have either preliminary or final status. The Quartus II software issues an informational message during the design compilation if the timing models are preliminary. [Table 5-14](#) shows the status of the Cyclone II device timing models.

Preliminary status means the timing model is subject to change. Initially, timing numbers are created using simulation results, process data, and other known parameters. These tests are used to make the preliminary numbers as close to the actual timing parameters as possible.

Final timing numbers are based on actual device operation and testing. These numbers reflect the actual performance of the device under worst-case voltage and junction temperature conditions.

Table 5–14. Cyclone II Device Timing Model Status

Device	Preliminary	Final
EP2C5	✓	
EP2C8	✓	
EP2C20	✓	
EP2C35	✓	
EP2C50	✓	
EP2C70	✓	

Performance

Table 5–15 shows Cyclone II performance for some common designs. All performance values were obtained by compiling LPM or MegaCore functions using the Quartus II software.

Table 5–15. Cyclone II Performance (Part 1 of 3) Notes (1) through (7)

Applications		Resources Used			Performance			Units
		LEs	M4K Memory Blocks	DSP Blocks	–6 Speed Grade	–7 Speed Grade	–8 Speed Grade	
LE	16-to-1 multiplexer (3)	11	0	0	384.02	321.64	292.22	MHz
	32-to-1 multiplexer (3)	24	0	0	294.2	262.32	204.24	MHz
	16-bit counter	16	0	0	401.6	349.4	310.65	MHz
	64-bit counter	64	0	0	155.98	138.83	126.48	MHz
Memory M4K block	Simple dual-port, single-clock RAM 128x36 bit (5),(7)	0	1	0	235.0	195.0	163.0	MHz
	Simple dual-port, dual-clock RAM 128x36 bit (6),(7)	0	1	0	235.0	195.0	163.0	MHz
	True dual-port, single-clock RAM 128x18 bit (5),(7)	0	1	0	235.0	195.0	163.0	MHz
	True dual-port, dual-clock RAM 128x18 bit (6),(7)	0	1	0	180.0	172.0	163.0	MHz

Table 5–15. Cyclone II Performance (Part 2 of 3) Notes (1) through (7)

Applications		Resources Used			Performance			Units
		LEs	M4K Memory Blocks	DSP Blocks	–6 Speed Grade	–7 Speed Grade	–8 Speed Grade	
	Single port RAM 128x36 bit (7)	0	1	0	235.0	195.0	163.0	MHz
	ROM 128x36 bit (7)	0	1	0	260.0	216.0	180.0	MHz
	FIFO 128x36 bit (7)	24	1	0	235.0	195.0	163.0	MHz
DSP block	9x9-bit multiplier (4)	0	0	1	260.01	216.73	180.57	MHz
	18x18-bit multiplier (4)	0	0	2	260.01	216.73	180.57	MHz
	18-bit,4tap FIR filter	113	0	8	182.64	151.12	128.05	MHz
Larger Designs	8-bit,16tap parallel FIR filter	52	0	4	133.56	112.09	92.23	MHz
	8-bit,1024pt,Streaming, 3Mults/5Adders FFT function	3191	22	9	139.58	118.59	99.07	MHz
	8-bit,1024pt,Streaming, 4Mults/2Adders FFT function	3041	22	12	250.25	198.76	165.15	MHz
	8-bit,1024pt,Single Output 1 Parallel FFT Engine, Burst, 3Mults/5Adders FFT function	1056	5	3	141.54	119.16	97.98	MHz
	8-bit,1024pt, Single Output 1 Parallel FFT Engine, Burst, 4Mults/2Adders FFT function	1006	5	4	260.01	213.58	180.05	MHz
	8-bit,1024pt,Single Output 2 Parallel FFT Engines, Burst, 3Mults/5Adders FFT function	1857	10	6	141.9	119.57	96.07	MHz
	8-bit,1024pt,Single Output 2 Parallel FFT Engines, Burst, 4Mults/2Adders FFT function	1757	10	8	235.07	195.0	163.02	MHz
	8-bit,1024pt,Quad Output 1 Parallel FFT Engine, Burst, 3Mults/5Adders FFT function	2550	10	9	141.22	118.09	99.43	MHz
	8-bit,1024pt,Quad Output 1 Parallel FFT Engine, Burst, 4Mults/2Adders FFT function	2400	10	12	260.01	211.72	151.01	MHz
	8-bit,1024pt,Quad Output 2 Parallel FFT Engines, Burst, 3Mults/5Adders FFT function	4343	14	18	140.78	118.41	97.8	MHz
	8-bit,1024pt,Quad Output 2 Parallel FFT Engines, Burst, 4Mults/2Adders FFT function	4043	14	24	229.2	192.38	163.02	MHz

Table 5–15. Cyclone II Performance (Part 3 of 3) Notes (1) through (7)

Applications		Resources Used			Performance			
		LEs	M4K Memory Blocks	DSP Blocks	–6 Speed Grade	–7 Speed Grade	–8 Speed Grade	Units
	8-bit, 1024pt, Quad Output 4 Parallel FFT Engines, Burst, 3Mults/5Adders FFT function	7496	28	36	140.98	118.11	98.16	MHz
	8-bit, 1024pt, Quad Output 4 Parallel FFT Engines, Burst, 4Mults/2Adders FFT function	6896	28	48	235.07	195.0	163.02	MHz
	8-bit, 1024pt, Quad Output 1 Parallel FFT Engine, Buffered Burst, 3Mults/5Adders FFT function	2934	18	9	142.24	118.39	97.63	MHz
	8-bit, 1024pt, Quad Output 1 Parallel FFT Engine, Buffered Burst, 4Mults/2Adders FFT function	2784	18	12	256.47	182.01	175.46	MHz
	8-bit, 1024pt, Quad Output 2 Parallel FFT Engines, Buffered Burst, 3Mults/5Adders FFT function	4720	30	18	141.3	118.49	99.06	MHz
	8-bit, 1024pt, Quad Output 2 Parallel FFT Engines, Buffered Burst, 4Mults/2Adders FFT function	4420	30	24	235.07	195.0	163.02	MHz
	8-bit, 1024pt, Quad Output 4 Parallel FFT Engines, Buffered Burst, 3Mults/5Adders FFT function	8053	60	36	140.25	117.86	93.75	MHz
	8-bit, 1024pt, Quad Output 4 Parallel FFT Engines, Buffered Burst, 4Mults/2Adders FFT function	7453	60	48	235.07	195.0	163.02	MHz

Notes to Table 5–15:

- (1) The design performance numbers were obtained using test designs in the Quartus II software version 5.1 SP2. Performance may vary depending on how the Quartus II software places and routes your design.
- (2) Applications that are not listed will be included in a future version of the data sheet.
- (3) This application uses registered inputs and outputs.
- (4) This application uses registered multiplier input and output stages within the DSP block.
- (5) This application uses the same clock source for both A and B ports.
- (6) This application uses independent clock sources for A and B ports.
- (7) This application uses PLL clock outputs that are globally routed to connect and drive M4K clock ports. Use of non-PLL clock sources or local routing to drive M4K clock ports may result in lower performance numbers than shown here. Refer to the Quartus II timing report for actual performance numbers.

Internal Timing

See Tables 5–16 through 5–19 for the internal timing parameters.

Table 5–16. LE_FF Internal Timing Microparameters

Parameter	-6 Speed Grade		-7 Speed Grade		-8 Speed Grade		Unit
	Minimum	Maximum	Minimum	Maximum	Minimum	Maximum	
T_{SU}	35		40		46		ps
T_H	266		286		306		ps
T_{CO}		250		277		304	ps
T_{CLR}	191		217		244		ps
T_{PRE}	191		217		244		ps
T_{CLKL}	1000		1111		1242		ps
T_{CLKH}	1000		1111		1242		ps
t_{LUT}		438		545		651	ps

Table 5–17. IOE Internal Timing Microparameters

Parameter	-6 Speed Grade		-7 Speed Grade		-8 Speed Grade		Unit
	Minimum	Maximum	Minimum	Maximum	Minimum	Maximum	
T_{SU}	76		89		101		ps
T_H	88		97		106		ps
T_{CO}		155		171		187	ps
$T_{PIN2COMBOUT_R}$		762		784		855	ps
$T_{PIN2COMBOUT_C}$		760		783		854	ps
$T_{COMBIN2PIN_R}$		2490		2689		2887	ps
$T_{COMBIN2PIN_C}$		2622		2831		3041	ps
T_{CLR}	137		151		165		ps
T_{PRE}	192		212		233		ps
T_{CLKL}	1000		1111		1242		ps
T_{CLKH}	1000		1111		1242		ps

Table 5–18. DSP Block Internal Timing Microparameters

Parameter	-6 Speed Grade		-7 Speed Grade		-8 Speed Grade		Unit
	Minimum	Maximum	Minimum	Maximum	Minimum	Maximum	
T_{SU}	47		54		62		ps
T_H	110		111		113		ps
T_{CO}		0		0		0	ps
$T_{INREG2PIPE9}$		1379		1872		2441	ps
$T_{INREG2PIPE18}$		1379		1872		2441	ps
$T_{PIPE2OUTREG}$		104		142		185	ps
T_{PD9}		2470		3353		4370	ps
T_{PD18}		2903		3941		5136	ps
T_{CLR}	2686		3129		3572		ps
T_{CLKL}	1923		2307		2769		ps
T_{CLKH}	1923		2307		2769		ps

Table 5–19. M4K Block Internal Timing Microparameters (Part 1 of 2)

Parameter	-6 Speed Grade		-7 Speed Grade		-8 Speed Grade		Unit
	Minimum	Maximum	Minimum	Maximum	Minimum	Maximum	
T_{M4KRC}		3764		4248		4736	ps
$T_{M4KWERESU}$	35		40		46		ps
$T_{M4KWEREH}$	234		250		267		ps
$T_{M4KBESU}$	35		40		46		ps
T_{M4KBEH}	234		250		267		ps
$T_{M4KDATAASU}$	35		40		46		ps
$T_{M4KDATAAH}$	234		250		267		ps
$T_{M4KADDRASU}$	35		40		46		ps
$T_{M4KADDRAH}$	234		250		267		ps
$T_{M4KDATABSU}$	35		40		46		ps
$T_{M4KDATA BH}$	234		250		267		ps
$T_{M4KRADDRBSU}$	35		40		46		ps

Table 5–19. M4K Block Internal Timing Microparameters (Part 2 of 2)

Parameter	-6 Speed Grade		-7 Speed Grade		-8 Speed Grade		Unit
	Minimum	Maximum	Minimum	Maximum	Minimum	Maximum	
$T_{M4KRADDRBH}$	234		250		267		ps
$T_{M4KDATAO1}$		724		826		930	ps
$T_{M4KDATAO2}$		3680		4157		4636	ps
$T_{M4KCLKH}$	1923		2307		2769		ps
$T_{M4KCLKL}$	1923		2307		2769		ps
T_{M4KCLR}	191		217		244		ps

Cyclone II Clock Timing Parameters

See [Tables 5–20 through 5–32](#) for Cyclone II clock timing parameters.

Table 5–20. Cyclone II Clock Timing Parameters

Symbol	Parameter
t_{CIN}	Delay from clock pad to I/O input register
t_{COUT}	Delay from clock pad to I/O output register
t_{PLLCIN}	Delay from PLL <i>inclk</i> pad to I/O input register
$t_{PLLCOUT}$	Delay from PLL <i>inclk</i> pad to I/O output register

EP2C5 Clock Timing Parameters

[Tables 5–21 and 5–22](#) show the clock timing parameters for EP2C5 devices

Table 5–21. EP2C5 Column Pins Global Clock Timing Parameters

Parameter	-6 Speed Grade	-7 Speed Grade	-8 Speed Grade	Unit
t_{CIN}	2.307	2.462	2.663	ns
t_{COUT}	2.344	2.497	2.696	ns
t_{PLLCIN}	0.339	0.324	0.361	ns
$t_{PLLCOUT}$	0.376	0.359	0.394	ns

Table 5–22. EP2C5 Row Pins Global Clock Timing Parameters

Parameter	-6 Speed Grade	-7 Speed Grade	-8 Speed Grade	Unit
t_{CIN}	2.185	2.326	2.515	ns
t_{COUT}	2.204	2.342	2.527	ns
t_{PLLCIN}	0.217	0.189	0.213	ns
$t_{PLLCOUT}$	0.236	0.205	0.225	ns

EP2C8 Clock Timing Parameters

Tables 5–23 and 5–24 show the clock timing parameters for EP2C8 devices.

Table 5–23. EP2C8 Column Pins Global Clock Timing Parameters

Parameter	-6 Speed Grade	-7 Speed Grade	-8 Speed Grade	Unit
t_{CIN}	2.394	2.554	2.762	ns
t_{COUT}	2.431	2.589	2.795	ns
t_{PLLCIN}	0.389	0.377	0.417	ns
$t_{PLLCOUT}$	0.426	0.412	0.45	ns

Table 5–24. EP2C8 Row Pins Global Clock Timing Parameters

Parameter	-6 Speed Grade	-7 Speed Grade	-8 Speed Grade	Unit
t_{CIN}	2.253	2.401	2.595	ns
t_{COUT}	2.272	2.417	2.607	ns
t_{PLLCIN}	0.248	0.224	0.25	ns
$t_{PLLCOUT}$	0.267	0.24	0.262	ns

EP2C20 Clock Timing Parameters

Tables 5–25 and 5–26 show the clock timing parameters for EP2C20 devices.

Table 5–25. EP2C20 Column Pins Global Clock Timing Parameters

Parameter	-6 Speed Grade	-7 Speed Grade	-8 Speed Grade	Unit
t_{CIN}	2.471	2.638	2.850	ns
t_{COUT}	2.508	2.673	2.883	ns
$t_{PLL\,CIN}$	0.231	0.209	0.231	ns
$t_{PLL\,COUT}$	0.268	0.244	0.264	ns

Table 5–26. EP2C20 Row Pins Global Clock Timing Parameters

Parameter	-6 Speed Grade	-7 Speed Grade	-8 Speed Grade	Unit
t_{CIN}	2.367	2.522	2.726	ns
t_{COUT}	2.386	2.538	2.738	ns
$t_{PLL\,CIN}$	0.125	0.093	0.107	ns
$t_{PLL\,COUT}$	0.144	0.109	0.119	ns

EP2C35 Clock Timing Parameters

Tables 5–27 and 5–28 show the clock timing parameters for EP2C35 devices.

Table 5–27. EP2C35 Column Pins Global Clock Timing Parameters

Parameter	-6 Speed Grade	-7 Speed Grade	-8 Speed Grade	Unit
t_{CIN}	2.611	2.784	3.008	ns
t_{COUT}	2.648	2.819	3.041	ns
$t_{PLL\,CIN}$	0.218	0.193	0.217	ns
$t_{PLL\,COUT}$	0.255	0.228	0.25	ns

Table 5–28. EP2C35 Row Pins Global Clock Timing Parameters

Parameter	-6 Speed Grade	-7 Speed Grade	-8 Speed Grade	Unit
t_{CIN}	2.480	2.641	2.852	ns
t_{COUT}	2.499	2.657	2.864	ns
$t_{PLL\,CIN}$	0.087	0.05	0.061	ns
$t_{PLL\,COUT}$	0.106	0.066	0.073	ns

EP2C50 Clock Timing Parameters

Tables 5–29 and 5–30 show the clock timing parameters for EP2C50 devices.

Table 5–29. EP2C50 Column Pins Global Clock Timing Parameters

Parameter	-6 Speed Grade	-7 Speed Grade	-8 Speed Grade	Unit
t_{CIN}	2.743	2.924	3.158	ns
t_{COUT}	2.780	2.959	3.191	ns
$t_{PLL\,CIN}$	0.269	0.246	0.273	ns
$t_{PLL\,COUT}$	0.306	0.281	0.306	ns

Table 5–30. EP2C50 Row Pins Global Clock Timing Parameters

Parameter	-6 Speed Grade	-7 Speed Grade	-8 Speed Grade	Unit
t_{CIN}	2.577	2.745	2.963	ns
t_{COUT}	2.596	2.761	2.975	ns
$t_{PLL\,CIN}$	0.103	0.067	0.078	ns
$t_{PLL\,COUT}$	0.122	0.083	0.09	ns

EP2C70 Clock Timing Parameters

Tables 5–31 and 5–32 show the clock timing parameters for EP2C70 devices

Table 5–31. EP2C70 Column Pins Global Clock Timing Parameters

Parameter	-6 Speed Grade	-7 Speed Grade	-8 Speed Grade	Unit
t_{CIN}	2.892	3.083	3.327	ns
t_{COUT}	2.929	3.118	3.360	ns
$t_{PLL\,CIN}$	0.335	0.317	0.351	ns
$t_{PLL\,COUT}$	0.372	0.352	0.384	ns

Table 5–32. EP2C70 Row Pins Global Clock Timing Parameters

Parameter	-6 Speed Grade	-7 Speed Grade	-8 Speed Grade	Unit
t_{CIN}	2.695	2.869	3.094	ns
t_{COUT}	2.714	2.885	3.106	ns
$t_{PLL\,CIN}$	0.138	0.103	0.118	ns
$t_{PLL\,COUT}$	0.157	0.119	0.13	ns

IOE Programmable Delay

See Tables 5-33 and 5-34 for IOE programmable delay.

Parameter	Paths Affected	Number of Settings	-6 Speed Grade		-7 Speed Grade		-8 Speed Grade		Unit
			Min Offset	Max Offset	Min Offset	Max Offset	Min Offset	Max Offset	
Input Delay from Pin to Internal Cells	Pad \geq I/O dataout to core	7	0	3827	0	4088	0	4349	ps
Input Delay from Pin to Input Register	Pad \geq I/O input register	56	0	8382	0	8836	0	9289	ps
Delay from Output Register to Output Pin	I/O output register \geq Pad	2	0	563	0	617	0	670	ps

Notes to Table 5-33:

- (1) The incremental values for the settings are generally linear. For exact values of each setting, please use the latest version of Quartus II software.

Parameter	Paths Affected	Number of Settings	-6 Speed Grade		-7 Speed Grade		-8 Speed Grade		Unit
			Min Offset	Max Offset	Min Offset	Max Offset	Min Offset	Max Offset	
Input Delay from Pin to Internal Cells	Pad \rightarrow I/O dataout to core	7	0	3776	0	4033	0	4290	ps
Input Delay from Pin to Input Register	Pad \rightarrow I/O input register	56	0	8258	0	8704	0	9149	ps
Delay from Output Register to Output Pin	I/O output register \rightarrow Pad	2	0	572	0	626	0	682	ps

Notes to Table 5-34:

- (1) The incremental values for the settings are generally linear. For exact values of each setting, please use the latest version of Quartus II software.

Default Capacitive Loading of Different I/O Standards

See [Table 5–35](#) for default capacitive loading of different I/O standards.

I/O Standard	Capacitive Load	Unit
LVTTL	0	pF
LVCMOS	0	pF
2.5 V	0	pF
1.8 V	0	pF
1.5 V	0	pF
PCI	10	pF
PCI-X	10	pF
SSTL-2 Class I	0	pF
SSTL-2 Class II	0	pF
SSTL-18 Class I	0	pF
SSTL-18 Class II	0	pF
1.5-V HSTL Class I	0	pF
1.5-V HSTL Class II	0	pF
1.8-V HSTL Class I	0	pF
1.8-V HSTL Class II	0	pF
Differential SSTL-2 Class I	0	pF
Differential SSTL-2 Class II	0	pF
Differential SSTL-18 Class I	0	pF
Differential SSTL-18 Class II	0	pF
1.5-V differential HSTL Class I	0	pF
1.5-V differential HSTL Class II	0	pF
1.8-V differential HSTL Class I	0	pF
1.8-V differential HSTL Class II	0	pF
LVDS	0	pF

I/O Delays

See Tables 5–36 through 5–40 for I/O delays.

Symbol	Parameter
t_{DIP}	Delay from I/O datain to output pad
t_{OP}	Delay from I/O output register to output pad
t_{PCOUT}	Delay from input pad to I/O dataout to core
t_{PI}	Delay from input pad to I/O input register

I/O Standard	Parameter	-6 Speed Grade	-7 Speed Grade	-8 Speed Grade	Unit
LVTTTL	t_{PI}	1409	1490	1619	ps
	t_{PCOUT}	760	783	854	ps
2.5V	t_{PI}	1379	1500	1620	ps
	t_{PCOUT}	730	793	855	ps
1.8V	t_{PI}	1559	1690	1821	ps
	t_{PCOUT}	910	983	1056	ps
1.5V	t_{PI}	1626	1759	1893	ps
	t_{PCOUT}	977	1052	1128	ps
LVCMOS	t_{PI}	1409	1490	1619	ps
	t_{PCOUT}	760	783	854	ps
SSTL_2_CLASS_I	t_{PI}	1177	1277	1377	ps
	t_{PCOUT}	528	570	612	ps
SSTL_2_CLASS_II	t_{PI}	1177	1277	1377	ps
	t_{PCOUT}	528	570	612	ps
SSTL_18_CLASS_I	t_{PI}	1214	1297	1382	ps
	t_{PCOUT}	565	590	617	ps
SSTL_18_CLASS_II	t_{PI}	1214	1297	1382	ps
	t_{PCOUT}	565	590	617	ps

Table 5–37. Cyclone II I/O Input Delay for Column Pins (Part 2 of 2)

I/O Standard	Parameter	-6 Speed Grade	-7 Speed Grade	-8 Speed Grade	Unit
1.5V_HSTL_CLASS_I	t_{PI}	1332	1438	1545	ps
	t_{PCOUT}	683	731	780	ps
1.5V_HSTL_CLASS_II	t_{PI}	1332	1438	1545	ps
	t_{PCOUT}	683	731	780	ps
1.8V_HSTL_CLASS_I	t_{PI}	1214	1297	1382	ps
	t_{PCOUT}	565	590	617	ps
1.8V_HSTL_CLASS_II	t_{PI}	1214	1297	1382	ps
	t_{PCOUT}	565	590	617	ps
DIFFERENTIAL_SSTL_2_CLASS_I	t_{PI}	1177	1277	1377	ps
	t_{PCOUT}	528	570	612	ps
DIFFERENTIAL_SSTL_2_CLASS_II	t_{PI}	1177	1277	1377	ps
	t_{PCOUT}	528	570	612	ps
DIFFERENTIAL_SSTL_18_CLASS_I	t_{PI}	1214	1297	1382	ps
	t_{PCOUT}	565	590	617	ps
DIFFERENTIAL_SSTL_18_CLASS_II	t_{PI}	1214	1297	1382	ps
	t_{PCOUT}	565	590	617	ps
DIFFERENTIAL_HSTL_18_CLASS_I	t_{PI}	1214	1297	1382	ps
	t_{PCOUT}	565	590	617	ps
DIFFERENTIAL_HSTL_18_CLASS_II	t_{PI}	1214	1297	1382	ps
	t_{PCOUT}	565	590	617	ps
DIFFERENTIAL_HSTL_15_CLASS_I	t_{PI}	1332	1438	1545	ps
	t_{PCOUT}	683	731	780	ps
DIFFERENTIAL_HSTL_15_CLASS_II	t_{PI}	1332	1438	1545	ps
	t_{PCOUT}	683	731	780	ps
LVDS	t_{PI}	1259	1337	1415	ps
	t_{PCOUT}	610	630	650	ps

Table 5–38. Cyclone II I/O Input Delay for Row Pins (Part 1 of 2)

I/O Standard	Parameter	-6 Speed Grade	-7 Speed Grade	-8 Speed Grade	Unit
LVTTL	t_{PI}	1328	1460	1641	ps
	t_{PCOUT}	762	784	855	ps
2.5V	t_{PI}	1298	1471	1645	ps
	t_{PCOUT}	732	795	859	ps
1.8V	t_{PI}	1477	1660	1844	ps
	t_{PCOUT}	911	984	1058	ps
1.5V	t_{PI}	1544	1729	1914	ps
	t_{PCOUT}	978	1053	1128	ps
LVCMOS	t_{PI}	1328	1460	1641	ps
	t_{PCOUT}	762	784	855	ps
SSTL_2_CLASS_I	t_{PI}	1095	1247	1399	ps
	t_{PCOUT}	529	571	613	ps
SSTL_2_CLASS_II	t_{PI}	1095	1247	1399	ps
	t_{PCOUT}	529	571	613	ps
SSTL_18_CLASS_I	t_{PI}	1132	1267	1405	ps
	t_{PCOUT}	566	591	619	ps
SSTL_18_CLASS_II	t_{PI}	1132	1267	1405	ps
	t_{PCOUT}	566	591	619	ps
1.5V_HSTL_CLASS_I	t_{PI}	1250	1409	1568	ps
	t_{PCOUT}	684	733	782	ps
1.5V_HSTL_CLASS_II	t_{PI}	1250	1409	1568	ps
	t_{PCOUT}	684	733	782	ps
1.8V_HSTL_CLASS_I	t_{PI}	1132	1267	1405	ps
	t_{PCOUT}	566	591	619	ps
1.8V_HSTL_CLASS_II	t_{PI}	1132	1267	1405	ps
	t_{PCOUT}	566	591	619	ps
DIFFERENTIAL_SSTL_2_CLASS_I	t_{PI}	1095	1247	1399	ps
	t_{PCOUT}	529	571	613	ps
DIFFERENTIAL_SSTL_2_CLASS_II	t_{PI}	1095	1247	1399	ps
	t_{PCOUT}	529	571	613	ps

Table 5–38. Cyclone II I/O Input Delay for Row Pins (Part 2 of 2)

I/O Standard	Parameter	-6 Speed Grade	-7 Speed Grade	-8 Speed Grade	Unit
DIFFERENTIAL_SSTL_18_CLASS_I	t_{PI}	1132	1267	1405	ps
	t_{PCOUT}	566	591	619	ps
DIFFERENTIAL_SSTL_18_CLASS_II	t_{PI}	1132	1267	1405	ps
	t_{PCOUT}	566	591	619	ps
DIFFERENTIAL_HSTL_18_CLASS_I	t_{PI}	1132	1267	1405	ps
	t_{PCOUT}	566	591	619	ps
DIFFERENTIAL_HSTL_18_CLASS_II	t_{PI}	1132	1267	1405	ps
	t_{PCOUT}	566	591	619	ps
DIFFERENTIAL_HSTL_15_CLASS_I	t_{PI}	1250	1409	1568	ps
	t_{PCOUT}	684	733	782	ps
DIFFERENTIAL_HSTL_15_CLASS_II	t_{PI}	1250	1409	1568	ps
	t_{PCOUT}	684	733	782	ps
LVDS	t_{PI}	1235	1375	1514	ps
	t_{PCOUT}	669	699	728	ps
PCI	t_{PI}	1312	1456	1633	ps
	t_{PCOUT}	746	780	847	ps
PCI-X	t_{PI}	1312	1456	1633	ps
	t_{PCOUT}	746	780	847	ps

Table 5–39. Cyclone II I/O Output Delay for Column Pins (Part 1 of 5)

I/O Standard	Drive Strength	Parameter	-6 Speed Grade	-7 Speed Grade	-8 Speed Grade	Unit	
LVTTTL	4mA	t_{OP}	2903	3125	3348	ps	
		t_{DIP}	3073	3319	3567	ps	
	8mA	t_{OP}	2670	2866	3061	ps	
		t_{DIP}	2840	3060	3280	ps	
	12mA	t_{OP}	2547	2735	2924	ps	
		t_{DIP}	2717	2929	3143	ps	
	16mA	t_{OP}	2478	2665	2851	ps	
		t_{DIP}	2648	2859	3070	ps	
	20mA	t_{OP}	2456	2641	2827	ps	
		t_{DIP}	2626	2835	3046	ps	
	24mA(1)	t_{OP}	2452	2637	2822	ps	
		t_{DIP}	2622	2831	3041	ps	
	LVCMOS	4mA	t_{OP}	2509	2695	2880	ps
			t_{DIP}	2679	2889	3099	ps
		8mA	t_{OP}	2473	2660	2847	ps
			t_{DIP}	2643	2854	3066	ps
12mA		t_{OP}	2428	2613	2797	ps	
		t_{DIP}	2598	2807	3016	ps	
16mA		t_{OP}	2403	2587	2772	ps	
		t_{DIP}	2573	2781	2991	ps	
20mA		t_{OP}	2378	2562	2745	ps	
		t_{DIP}	2548	2756	2964	ps	
24mA(1)		t_{OP}	2382	2566	2749	ps	
		t_{DIP}	2552	2760	2968	ps	

Table 5–39. Cyclone II I/O Output Delay for Column Pins (Part 2 of 5)

I/O Standard	Drive Strength	Parameter	-6 Speed Grade	-7 Speed Grade	-8 Speed Grade	Unit	
2.5V	4mA	t_{OP}	2478	2614	2750	ps	
		t_{DIP}	2648	2808	2969	ps	
	8mA	t_{OP}	2307	2434	2561	ps	
		t_{DIP}	2477	2628	2780	ps	
	12mA	t_{OP}	2192	2314	2437	ps	
		t_{DIP}	2362	2508	2656	ps	
	16mA(1)	t_{OP}	2152	2263	2382	ps	
		t_{DIP}	2322	2457	2601	ps	
1.8V	2mA	t_{OP}	3988	4279	4570	ps	
		t_{DIP}	4158	4473	4789	ps	
	4mA	t_{OP}	3301	3538	3775	ps	
		t_{DIP}	3471	3732	3994	ps	
	6mA	t_{OP}	2993	3195	3398	ps	
		t_{DIP}	3163	3389	3617	ps	
	8mA	t_{OP}	2882	3074	3266	ps	
		t_{DIP}	3052	3268	3485	ps	
	10mA	t_{OP}	2853	3041	3230	ps	
		t_{DIP}	3023	3235	3449	ps	
	12mA(1)	t_{OP}	2853	3041	3230	ps	
		t_{DIP}	3023	3235	3449	ps	
	1.5V	2mA	t_{OP}	4477	4870	5263	ps
			t_{DIP}	4647	5064	5482	ps
4mA		t_{OP}	3649	3965	4281	ps	
		t_{DIP}	3819	4159	4500	ps	
6mA		t_{OP}	3527	3823	4119	ps	
		t_{DIP}	3697	4017	4338	ps	
8mA(1)		t_{OP}	3537	3827	4118	ps	
		t_{DIP}	3707	4021	4337	ps	
SSTL_2_CLASS_I	8mA	t_{OP}	2388	2516	2645	ps	
		t_{DIP}	2558	2710	2864	ps	
	12mA(1)	t_{OP}	2277	2401	2525	ps	
		t_{DIP}	2447	2595	2744	ps	

Table 5–39. Cyclone II I/O Output Delay for Column Pins (Part 3 of 5)

I/O Standard	Drive Strength	Parameter	-6 Speed Grade	-7 Speed Grade	-8 Speed Grade	Unit	
SSTL_2_CLASS_II	16mA	t_{OP}	2245	2365	2486	ps	
		t_{DIP}	2415	2559	2705	ps	
	20mA	t_{OP}	2231	2351	2471	ps	
		t_{DIP}	2401	2545	2690	ps	
	24mA(1)	t_{OP}	2225	2345	2465	ps	
		t_{DIP}	2395	2539	2684	ps	
SSTL_18_CLASS_I	6mA	t_{OP}	3140	3345	3549	ps	
		t_{DIP}	3310	3539	3768	ps	
	8mA	t_{OP}	3086	3287	3489	ps	
		t_{DIP}	3256	3481	3708	ps	
	10mA	t_{OP}	2980	3171	3361	ps	
		t_{DIP}	3150	3365	3580	ps	
	12mA(1)	t_{OP}	2980	3171	3361	ps	
		t_{DIP}	3150	3365	3580	ps	
	SSTL_18_CLASS_II	16mA	t_{OP}	2905	3088	3270	ps
			t_{DIP}	3075	3282	3489	ps
18mA(1)		t_{OP}	2900	3082	3264	ps	
		t_{DIP}	3070	3276	3483	ps	
1.8V_HSTL_CLASS_I	8mA	t_{OP}	3222	3424	3625	ps	
		t_{DIP}	3392	3618	3844	ps	
	10mA	t_{OP}	3090	3279	3469	ps	
		t_{DIP}	3260	3473	3688	ps	
	12mA(1)	t_{OP}	3090	3279	3469	ps	
		t_{DIP}	3260	3473	3688	ps	
1.8V_HSTL_CLASS_II	16mA	t_{OP}	2936	3107	3278	ps	
		t_{DIP}	3106	3301	3497	ps	
	18mA	t_{OP}	2924	3101	3279	ps	
		t_{DIP}	3094	3295	3498	ps	
	20mA(1)	t_{OP}	2926	3096	3266	ps	
		t_{DIP}	3096	3290	3485	ps	

Table 5–39. Cyclone II I/O Output Delay for Column Pins (Part 4 of 5)

I/O Standard	Drive Strength	Parameter	-6 Speed Grade	-7 Speed Grade	-8 Speed Grade	Unit	
1.5V_HSTL_CLASS_I	8mA	t_{OP}	4292	4637	4981	ps	
		t_{DIP}	4462	4831	5200	ps	
	10mA	t_{OP}	4031	4355	4680	ps	
		t_{DIP}	4201	4549	4899	ps	
	12mA(1)	t_{OP}	4031	4355	4680	ps	
		t_{DIP}	4201	4549	4899	ps	
1.5V_HSTL_CLASS_II	16mA(1)	t_{OP}	3844	4125	4406	ps	
		t_{DIP}	4014	4319	4625	ps	
DIFFERENTIAL_SSTL_2_CLASS_I	8mA	t_{OP}	2388	2516	2645	ps	
		t_{DIP}	2558	2710	2864	ps	
	12mA	t_{OP}	2277	2401	2525	ps	
		t_{DIP}	2447	2595	2744	ps	
DIFFERENTIAL_SSTL_2_CLASS_II	16mA	t_{OP}	2245	2365	2486	ps	
		t_{DIP}	2415	2559	2705	ps	
	20mA	t_{OP}	2231	2351	2471	ps	
		t_{DIP}	2401	2545	2690	ps	
	24mA	t_{OP}	2225	2345	2465	ps	
		t_{DIP}	2395	2539	2684	ps	
DIFFERENTIAL_SSTL_18_CLASS_I	6mA	t_{OP}	3140	3345	3549	ps	
		t_{DIP}	3310	3539	3768	ps	
	8mA	t_{OP}	3086	3287	3489	ps	
		t_{DIP}	3256	3481	3708	ps	
	10mA	t_{OP}	2980	3171	3361	ps	
		t_{DIP}	3150	3365	3580	ps	
	12mA	t_{OP}	2980	3171	3361	ps	
		t_{DIP}	3150	3365	3580	ps	
	DIFFERENTIAL_SSTL_18_CLASS_II	16mA	t_{OP}	2905	3088	3270	ps
			t_{DIP}	3075	3282	3489	ps
18mA		t_{OP}	2900	3082	3264	ps	
		t_{DIP}	3070	3276	3483	ps	

Table 5–39. Cyclone II I/O Output Delay for Column Pins (Part 5 of 5)

I/O Standard	Drive Strength	Parameter	-6 Speed Grade	-7 Speed Grade	-8 Speed Grade	Unit
DIFFERENTIAL_HSTL_18_CLASS_I	8mA	t_{OP}	3222	3424	3625	ps
		t_{DIP}	3392	3618	3844	ps
	10mA	t_{OP}	3090	3279	3469	ps
		t_{DIP}	3260	3473	3688	ps
	12mA	t_{OP}	3090	3279	3469	ps
		t_{DIP}	3260	3473	3688	ps
DIFFERENTIAL_HSTL_18_CLASS_II	16mA	t_{OP}	2936	3107	3278	ps
		t_{DIP}	3106	3301	3497	ps
	18mA	t_{OP}	2924	3101	3279	ps
		t_{DIP}	3094	3295	3498	ps
	20mA	t_{OP}	2926	3096	3266	ps
		t_{DIP}	3096	3290	3485	ps
DIFFERENTIAL_HSTL_15_CLASS_I	8mA	t_{OP}	4292	4637	4981	ps
		t_{DIP}	4462	4831	5200	ps
	10mA	t_{OP}	4031	4355	4680	ps
		t_{DIP}	4201	4549	4899	ps
	12mA	t_{OP}	4031	4355	4680	ps
		t_{DIP}	4201	4549	4899	ps
DIFFERENTIAL_HSTL_15_CLASS_II	16mA	t_{OP}	3844	4125	4406	ps
		t_{DIP}	4014	4319	4625	ps
LVDS	-	t_{OP}	2243	2344	2445	ps
		t_{DIP}	2413	2538	2664	ps
RSDS	-	t_{OP}	2243	2344	2445	ps
		t_{DIP}	2413	2538	2664	ps
MINI_LVDS	-	t_{OP}	2243	2344	2445	ps
		t_{DIP}	2413	2538	2664	ps

Note to Table 5–39:

(1) This is the default setting in Quartus II software.

Table 5–40. Cyclone II I/O Output Delay for Row Pins (Part 1 of 4)

I/O Standard	Drive Strength	Parameter	-6 Speed Grade	-7 Speed Grade	-8 Speed Grade	Unit	
LVTTTL	4mA	t_{OP}	2539	2694	2891	ps	
		t_{DIP}	2747	2931	3158	ps	
	8mA	t_{OP}	2411	2587	2762	ps	
		t_{DIP}	2619	2824	3029	ps	
	12mA	t_{OP}	2282	2452	2620	ps	
		t_{DIP}	2490	2689	2887	ps	
	16mA	t_{OP}	2286	2455	2624	ps	
		t_{DIP}	2494	2692	2891	ps	
	20mA	t_{OP}	2245	2413	2580	ps	
		t_{DIP}	2453	2650	2847	ps	
	24mA(1)	t_{OP}	2253	2422	2589	ps	
		t_{DIP}	2461	2659	2856	ps	
	LVCMOS	4mA	t_{OP}	2231	2396	2561	ps
			t_{DIP}	2439	2633	2828	ps
8mA		t_{OP}	2260	2429	2597	ps	
		t_{DIP}	2468	2666	2864	ps	
12mA(1)		t_{OP}	2217	2383	2549	ps	
		t_{DIP}	2425	2620	2816	ps	
2.5V	4mA	t_{OP}	2350	2477	2604	ps	
		t_{DIP}	2558	2714	2871	ps	
	8mA(1)	t_{OP}	2177	2296	2415	ps	
		t_{DIP}	2385	2533	2682	ps	

Table 5–40. Cyclone II I/O Output Delay for Row Pins (Part 2 of 4)

I/O Standard	Drive Strength	Parameter	-6 Speed Grade	-7 Speed Grade	-8 Speed Grade	Unit	
1.8V	2mA	t_{OP}	3657	3927	4196	ps	
		t_{DIP}	3865	4164	4463	ps	
	4mA	t_{OP}	3010	3226	3440	ps	
		t_{DIP}	3218	3463	3707	ps	
	6mA	t_{OP}	2857	3050	3242	ps	
		t_{DIP}	3065	3287	3509	ps	
	8mA	t_{OP}	2714	2897	3078	ps	
		t_{DIP}	2922	3134	3345	ps	
	10mA	t_{OP}	2714	2897	3078	ps	
		t_{DIP}	2922	3134	3345	ps	
	12mA(1)	t_{OP}	2678	2856	3034	ps	
		t_{DIP}	2886	3093	3301	ps	
	1.5V	2mA	t_{OP}	4127	4492	4855	ps
			t_{DIP}	4335	4729	5122	ps
4mA		t_{OP}	3452	3747	4042	ps	
		t_{DIP}	3660	3984	4309	ps	
6mA(1)		t_{OP}	3452	3747	4042	ps	
		t_{DIP}	3660	3984	4309	ps	
SSTL_2_CLASS_I	8mA	t_{OP}	2152	2268	2382	ps	
		t_{DIP}	2360	2505	2649	ps	
	12mA(1)	t_{OP}	2131	2246	2360	ps	
		t_{DIP}	2339	2483	2627	ps	
SSTL_2_CLASS_II	16mA(1)	t_{OP}	2067	2177	2287	ps	
		t_{DIP}	2275	2414	2554	ps	
SSTL_18_CLASS_I	6mA	t_{OP}	2828	3018	3206	ps	
		t_{DIP}	3036	3255	3473	ps	
	8mA	t_{OP}	2832	3024	3215	ps	
		t_{DIP}	3040	3261	3482	ps	
	10mA(1)	t_{OP}	2806	2990	3173	ps	
		t_{DIP}	3014	3227	3440	ps	

Table 5–40. Cyclone II I/O Output Delay for Row Pins (Part 3 of 4)

I/O Standard	Drive Strength	Parameter	-6 Speed Grade	-7 Speed Grade	-8 Speed Grade	Unit
1.8V_HSTL_CLASS_I	8mA	t_{OP}	2853	3017	3184	ps
		t_{DIP}	3061	3254	3451	ps
	10mA	t_{OP}	2842	3011	3179	ps
		t_{DIP}	3050	3248	3446	ps
	12mA(1)	t_{OP}	2842	3011	3179	ps
		t_{DIP}	3050	3248	3446	ps
1.5V_HSTL_CLASS_I	8mA(1)	t_{OP}	3642	3917	4191	ps
		t_{DIP}	3850	4154	4458	ps
DIFFERENTIAL_SSTL_2_CLASS_I	8mA	t_{OP}	2152	2268	2382	ps
		t_{DIP}	2360	2505	2649	ps
	12mA	t_{OP}	2131	2246	2360	ps
		t_{DIP}	2339	2483	2627	ps
DIFFERENTIAL_SSTL_2_CLASS_II	16mA	t_{OP}	2067	2177	2287	ps
		t_{DIP}	2275	2414	2554	ps
DIFFERENTIAL_SSTL_18_CLASS_I	6mA	t_{OP}	2828	3018	3206	ps
		t_{DIP}	3036	3255	3473	ps
	8mA	t_{OP}	2832	3024	3215	ps
		t_{DIP}	3040	3261	3482	ps
	10mA	t_{OP}	2806	2990	3173	ps
		t_{DIP}	3014	3227	3440	ps
DIFFERENTIAL_HSTL_18_CLASS_I	8mA	t_{OP}	2853	3017	3184	ps
		t_{DIP}	3061	3254	3451	ps
	10mA	t_{OP}	2842	3011	3179	ps
		t_{DIP}	3050	3248	3446	ps
	12mA	t_{OP}	2842	3011	3179	ps
		t_{DIP}	3050	3248	3446	ps
DIFFERENTIAL_HSTL_15_CLASS_I	8mA	t_{OP}	3642	3917	4191	ps
		t_{DIP}	3850	4154	4458	ps
LVDS	-	t_{OP}	2089	2184	2278	ps
		t_{DIP}	2297	2421	2545	ps
RSDS	-	t_{OP}	2089	2184	2278	ps
		t_{DIP}	2297	2421	2545	ps

Table 5–40. Cyclone II I/O Output Delay for Row Pins (Part 4 of 4)

I/O Standard	Drive Strength	Parameter	-6 Speed Grade	-7 Speed Grade	-8 Speed Grade	Unit
MINI_LVDS	-	t _{OP}	2089	2184	2278	ps
		t _{DIP}	2297	2421	2545	ps
PCI	-	t _{OP}	2070	2214	2358	ps
		t _{DIP}	2278	2451	2625	ps
PCI_X	-	t _{OP}	2070	2214	2358	ps
		t _{DIP}	2278	2451	2625	ps

Notes to Table 5–45:

(1) This is the default setting in Quartus II software.

Maximum Input & Output Clock Rate

Tables 5–41 through 5–44 show the I/O toggle rates for Cyclone II devices.

Table 5–41. Cyclone II Maximum Input Clock Rate for Column Pins (Part 1 of 2)

I/O Standard	-6 Speed Grade	-7 Speed Grade	-8 Speed Grade	Unit
LVTTL	450	405	360	MHz
2.5V	450	405	360	MHz
1.8V	450	405	360	MHz
1.5V	300	270	240	MHz
LVCMOS	450	405	360	MHz
SSTL_2_CLASS_I	500	500	500	MHz
SSTL_2_CLASS_II	500	500	500	MHz
SSTL_18_CLASS_I	500	500	500	MHz
SSTL_18_CLASS_II	500	500	500	MHz
1.5V_HSTL_CLASS_I	500	500	500	MHz
1.5V_HSTL_CLASS_II	500	500	500	MHz
1.8V_HSTL_CLASS_I	500	500	500	MHz
1.8V_HSTL_CLASS_II	500	500	500	MHz
DIFFERENTIAL_SSTL_2_CLASS_I	500	500	500	MHz
DIFFERENTIAL_SSTL_2_CLASS_II	500	500	500	MHz
DIFFERENTIAL_SSTL_18_CLASS_I	500	500	500	MHz
DIFFERENTIAL_SSTL_18_CLASS_II	500	500	500	MHz

Table 5–41. Cyclone II Maximum Input Clock Rate for Column Pins (Part 2 of 2)

I/O Standard	-6 Speed Grade	-7 Speed Grade	-8 Speed Grade	Unit
DIFFERENTIAL_HSTL_18_CLASS_I	500	500	500	MHz
DIFFERENTIAL_HSTL_18_CLASS_II	500	500	500	MHz
DIFFERENTIAL_HSTL_15_CLASS_I	500	500	500	MHz
DIFFERENTIAL_HSTL_15_CLASS_II	500	500	500	MHz
LVDS	402	402	402	MHz

Table 5–42. Cyclone II Maximum Input Clock Rate for Row Pins

I/O Standard	-6 Speed Grade	-7 Speed Grade	-8 Speed Grade	Unit
LVTTTL	450	405	360	MHz
2.5V	450	405	360	MHz
1.8V	450	405	360	MHz
1.5V	300	270	240	MHz
LVCMOS	450	405	360	MHz
SSTL_2_CLASS_I	500	500	500	MHz
SSTL_2_CLASS_II	500	500	500	MHz
SSTL_18_CLASS_I	500	500	500	MHz
SSTL_18_CLASS_II	500	500	500	MHz
1.5V_HSTL_CLASS_I	500	500	500	MHz
1.5V_HSTL_CLASS_II	500	500	500	MHz
1.8V_HSTL_CLASS_I	500	500	500	MHz
1.8V_HSTL_CLASS_II	500	500	500	MHz
DIFFERENTIAL_SSTL_2_CLASS_I	500	500	500	MHz
DIFFERENTIAL_SSTL_2_CLASS_II	500	500	500	MHz
DIFFERENTIAL_SSTL_18_CLASS_I	500	500	500	MHz
DIFFERENTIAL_SSTL_18_CLASS_II	500	500	500	MHz
DIFFERENTIAL_HSTL_18_CLASS_I	500	500	500	MHz
DIFFERENTIAL_HSTL_18_CLASS_II	500	500	500	MHz
DIFFERENTIAL_HSTL_15_CLASS_I	500	500	500	MHz
DIFFERENTIAL_HSTL_15_CLASS_II	500	500	500	MHz
LVDS	402	402	402	MHz
PCI	350	315	280	MHz
PCI-X	350	315	280	MHz

Table 5-43. Cyclone II Maximum Output Clock Rate for Column Pins

I/O Standard	Drive Strength	-6 Speed Grade	-7 Speed Grade	-8 Speed Grade	Unit
LVTTTL	4mA	120	100	80	MHz
	8mA	200	170	140	MHz
	12mA	280	230	190	MHz
	16mA	290	240	200	MHz
	20mA	330	280	230	MHz
	24mA (1)	360	300	250	MHz
LVCMOS	4mA	250	210	170	MHz
	8mA	280	230	190	MHz
	12mA	310	260	210	MHz
	16mA	320	270	220	MHz
	20mA	350	290	240	MHz
	24mA (1)	370	310	250	MHz
2.5V	4mA	180	150	120	MHz
	8mA	280	230	190	MHz
	12mA	440	370	300	MHz
	16mA (1)	450	405	350	MHz
1.8V	2mA	120	100	80	MHz
	4mA	180	150	120	MHz
	6mA	220	180	150	MHz
	8mA	240	200	160	MHz
	10mA	300	250	210	MHz
	12mA (1)	350	290	240	MHz
1.5V	2mA	80	60	50	MHz
	4mA	130	110	90	MHz
	6mA	180	150	120	MHz
	8mA (1)	230	190	160	MHz
SSTL_2_CLASS_I	8mA	400	340	280	MHz
	12mA (1)	400	340	280	MHz
SSTL_2_CLASS_II	16mA	350	290	240	MHz
	20mA	400	340	280	MHz
	24mA (1)	400	340	280	MHz

Table 5–43. Cyclone II Maximum Output Clock Rate for Column Pins

I/O Standard	Drive Strength	-6 Speed Grade	-7 Speed Grade	-8 Speed Grade	Unit
SSTL_18_CLASS_I	6mA	260	220	180	MHz
	8mA	260	220	180	MHz
	10mA	270	220	180	MHz
	12mA (1)	280	230	190	MHz
SSTL_18_CLASS_II	16mA	260	220	180	MHz
	18mA (1)	270	220	180	MHz
1.8V_HSTL_CLASS_I	8mA	260	220	180	MHz
	10mA	300	250	210	MHz
	12mA (1)	320	270	220	MHz
1.8V_HSTL_CLASS_II	16mA	230	190	160	MHz
	18mA	240	200	160	MHz
	20mA (1)	250	210	170	MHz
1.5V_HSTL_CLASS_I	8mA	210	170	140	MHz
	10mA	220	180	150	MHz
	12mA (1)	230	190	160	MHz
1.5V_HSTL_CLASS_II	16mA (1)	210	170	140	MHz
DIFFERENTIAL_SSTL_2_CLASS_I	8mA	400	340	280	MHz
	12mA	400	340	280	MHz
DIFFERENTIAL_SSTL_2_CLASS_II	16mA	350	290	240	MHz
	20mA	400	340	280	MHz
	24mA	400	340	280	MHz
DIFFERENTIAL_SSTL_18_CLASS_I	6mA	260	220	180	MHz
	8mA	260	220	180	MHz
	10mA	270	220	180	MHz
	12mA	280	230	190	MHz
DIFFERENTIAL_SSTL_18_CLASS_II	16mA	260	220	180	MHz
	18mA	270	220	180	MHz
DIFFERENTIAL_HSTL_18_CLASS_I	8mA	260	220	180	MHz
	10mA	300	250	210	MHz
	12mA	320	270	220	MHz
DIFFERENTIAL_HSTL_18_CLASS_II	16mA	230	190	160	MHz
	18mA	240	200	160	MHz
	20mA	250	210	170	MHz

Table 5–43. Cyclone II Maximum Output Clock Rate for Column Pins

I/O Standard	Drive Strength	-6 Speed Grade	-7 Speed Grade	-8 Speed Grade	Unit
DIFFERENTIAL_HSTL_15 _CLASS_I	8mA	210	170	140	MHz
	10mA	220	180	150	MHz
	12mA	230	190	160	MHz
DIFFERENTIAL_HSTL_15 _CLASS_II	16mA	210	170	140	MHz
LVDS	-	400	340	280	MHz
RSDS	-	400	340	280	MHz
MINI_LVDS	-	400	340	280	MHz

Note to [Table 5–43](#):

(1) This is the default setting in Quartus II software.

Table 5–44. Cyclone II Maximum Output Clock Rate for Row Pins

I/O Standard	Drive Strength	-6 Speed Grade	-7 Speed Grade	-8 Speed Grade	Unit
LVTTTL	4mA	120	100	80	MHz
	8mA	200	170	140	MHz
	12mA	280	230	190	MHz
	16mA	290	240	200	MHz
	20mA	330	280	230	MHz
	24mA (1)	360	300	250	MHz
LVCMOS	4mA	250	210	170	MHz
	8mA	280	230	190	MHz
	12mA (1)	310	260	210	MHz
2.5V	4mA	180	150	120	MHz
	8mA (1)	280	230	190	MHz
1.8V	2mA	120	100	80	MHz
	4mA	180	150	120	MHz
	6mA	220	180	150	MHz
	8mA	240	200	160	MHz
	10mA	300	250	210	MHz
	12mA (1)	350	290	240	MHz

Table 5–44. Cyclone II Maximum Output Clock Rate for Row Pins

I/O Standard	Drive Strength	-6 Speed Grade	-7 Speed Grade	-8 Speed Grade	Unit
1.5V	2mA	80	60	50	MHz
	4mA	130	110	90	MHz
	6mA (1)	180	150	120	MHz
SSTL_2_CLASS_I	8mA	400	340	280	MHz
	12mA (1)	400	340	280	MHz
SSTL_2_CLASS_II	16mA (1)	350	290	240	MHz
SSTL_18_CLASS_I	6mA	260	220	180	MHz
	8mA	260	220	180	MHz
	10mA (1)	270	220	180	MHz
HSTL_18_CLASS_I	8mA	260	220	180	MHz
	10mA	300	250	210	MHz
	12mA (1)	320	270	220	MHz
HSTL_15_CLASS_I	8mA (1)	210	170	140	MHz
DIFFERENTIAL_SSTL_2_CLASS_I	8mA	400	340	280	MHz
	12mA	400	340	280	MHz
DIFFERENTIAL_SSTL_2_CLASS_II	16mA	350	290	240	MHz
DIFFERENTIAL_SSTL_18_CLASS_I	6mA	260	220	180	MHz
	8mA	260	220	180	MHz
	10mA	270	220	180	MHz
DIFFERENTIAL_HSTL_18_CLASS_I	8mA	260	220	180	MHz
	10mA	300	250	210	MHz
	12mA	320	270	220	MHz
DIFFERENTIAL_HSTL_15_CLASS_I	8mA	210	170	140	MHz
LVDS	-	400	340	280	MHz
RSDS	-	400	340	280	MHz
MINI_LVDS	-	400	340	280	MHz
PCI	-	350	315	280	MHz
PCI_X	-	350	315	280	MHz

Note to Table 5–44:

(1) This is the default setting in Quartus II software.

High Speed I/O Timing Specifications

The timing analysis for LVDS, mini-LVDS, and RSDS is different compared to other I/O standards because the data communication is source-synchronous.

You should also consider board skew, cable skew, and clock jitter in your calculation. This section provides details on the timing parameters for high-speed I/O standards in Cyclone II devices.

Table 5–45 defines the parameters of the timing diagram shown in Figure 5–3.

Parameter	Symbol	Description
High-speed clock	f_{HSCKLK}	High-speed receiver and transmitter input and output clock frequency.
Duty cycle	t_{DUTY}	Duty cycle on high-speed transmitter output clock.
High-speed I/O data rate	HSIODR	High-speed receiver and transmitter input and output data rate.
Time Unit Interval	TUI	$\text{TUI} = 1/\text{HSIODR}$.
Channel-to-channel skew	TCCS	The timing difference between the fastest and slowest output edges, including t_{CO} variation and clock skew. The clock is included in the TCCS measurement. $\text{TCCS} = \text{TUI} - \text{SW} - (2 \times \text{RSKM})$
Sampling window	SW	The period of time during which the data must be valid in order for you to capture it correctly. Sampling window is the sum of the setup time, hold time, and jitter. The window of $t_{\text{SU}} + t_{\text{H}}$ is expected to be centered in the sampling window. $\text{SW} = \text{TUI} - \text{TCCS} - (2 \times \text{RSKM})$
Receiver input skew margin	RSKM	RSKM is defined by the total margin left after accounting for the sampling window and TCCS. $\text{RSKM} = (\text{TUI} - \text{SW} - \text{TCCS}) / 2$
Input jitter (peak to peak)		Peak-to-peak input jitter on high-speed PLLs.
Output jitter (peak to peak)		Peak-to-peak output jitter on high-speed PLLs.
Signal rise time	t_{RISE}	Low-to-high transmission time.
Signal fall time	t_{FALL}	High-to-low transmission time.
Lock time	t_{LOCK}	Lock time for high-speed transmitter and receiver PLLs.

Figure 5–3. High-Speed I/O Timing Diagram

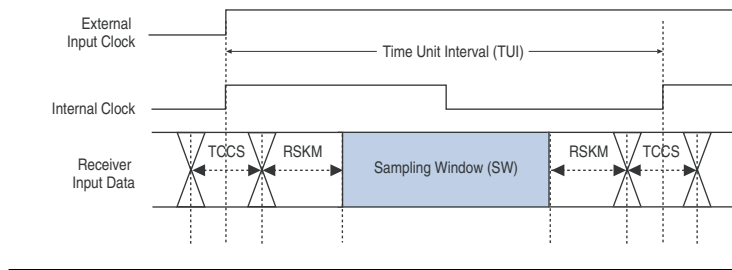
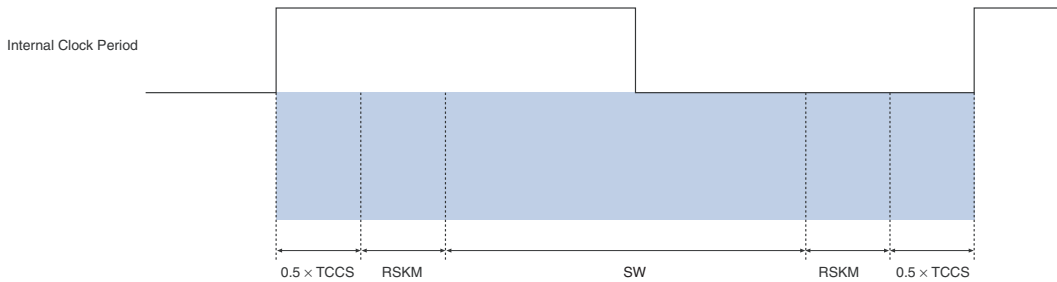

Figure 5–4 shows the high-speed I/O timing budget.

Figure 5–4. High-Speed I/O Timing Budget Note (1)



Note to Figure 5–4:

- (1) The equation for the high-speed I/O timing budget is:

$$\text{period} = \text{TCCS} + \text{RSKM} + \text{SW} + \text{RSKM}$$

Table 5–46 shows the RSDS timing budget for Cyclone II devices at 311 Mbps. RSDS is supported for transmitting from Cyclone II devices. Cyclone II devices cannot receive RSDS data because the devices are intended for applications where they will be driving display drivers.

Cyclone II devices support a maximum RSDS data rate of 311 Mbps using DDIO registers. Cyclone II devices support RSDS only in the commercial temperature range.

Table 5–46. RSDS Transmitter Timing Specification

Symbol	Conditions	-6 Speed Grade			-7 Speed Grade			-8 Speed Grade			Unit
		Min	Typ	Max(1)	Min	Typ	Max(1)	Min	Typ	Max(1)	
f_{HSCLK} (input clock frequency)	×10	10		155.5	10		155.5	10		155.5	Mhz
	×8	10		155.5	10		155.5	10		155.5	Mhz
	×7	10		155.5	10		155.5	10		155.5	Mhz
	×4	10		155.5	10		155.5	10		155.5	Mhz
	×2	10		155.5	10		155.5	10		155.5	Mhz
	×1	10		311	10		311	10		311	Mhz
Device operation in Mbps	×10	100		311	100		311	100		311	Mbps
	×8	80		311	80		311	80		311	Mbps
	×7	70		311	70		311	70		311	Mbps
	×4	40		311	40		311	40		311	Mbps
	×2	20		311	20		311	20		311	Mbps
	×1	10		311	10		311	10		311	Mbps
t_{DUTY}		45		55	45		55	45		55	%
TCCS				200			200			200	ps
Output jitter (peak to peak)				500			500			500	ps
t_{RISE}	20–80%, $C_{\text{LOAD}} = 5 \text{ pF}$		500			500			500		ps
t_{FALL}	80–20%, $C_{\text{LOAD}} = 5 \text{ pF}$		500			500			500		ps
t_{LOCK}				100			100			100	μs

Note to Table 5–46:

- (1) These specifications are for a three-resistor RSDS implementation. For single-resistor RSDS in ×10 through ×2 modes, the maximum data rate is 170 Mbps and the corresponding maximum input clock frequency is 85 MHz. For single-resistor RSDS in ×1 mode, the maximum data rate is 170 Mbps and the maximum input clock frequency is 170 MHz. See Chapter 11 for more information on the different RSDS implementations.

In order to determine the transmitter timing requirements, RSDS receiver timing requirements on the other end of the link must be taken into consideration. RSDS receiver timing parameters are typically defined as

t_{SU} and t_H requirements. Therefore, the transmitter timing parameter specifications are t_{CO} (minimum) and t_{CO} (maximum). Refer to Figure 5-4 for the timing budget.

The AC timing requirements for RSDS are shown in Figure 5-5.

Figure 5-5. RSDS Transmitter Clock to Data Relationship

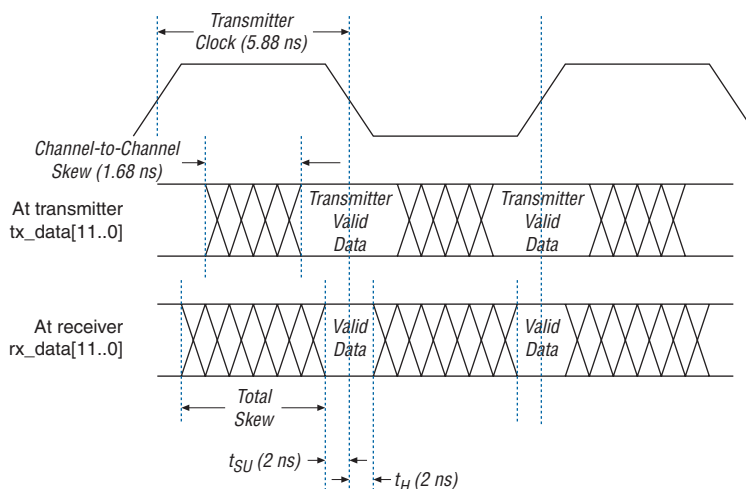

Table 5-47 shows the mini-LVDS transmitter timing budget for Cyclone II devices at 311 Mbps. Cyclone II devices can not receive mini-LVDS data because the devices are intended for applications where they will be driving display drivers. A maximum mini-LVDS data rate of 311 Mbps is supported for Cyclone II devices using DDIO registers. Cyclone II devices support mini-LVDS only in the commercial temperature range.

Table 5-47. Mini-LVDS Transmitter Timing Specification (Part 1 of 2)

Symbol	Conditions	-6 Speed Grade			-7 Speed Grade			-8 Speed Grade			Unit
		Min	Typ	Max	Min	Typ	Max	Min	Typ	Max	
f_{HSCLK} (input clock frequency)	x10	10		155.5	10		155.5	10		155.5	Mhz
	x8	10		155.5	10		155.5	10		155.5	Mhz
	x7	10		155.5	10		155.5	10		155.5	Mhz
	x4	10		155.5	10		155.5	10		155.5	Mhz
	x2	10		155.5	10		155.5	10		155.5	Mhz
	x1	10		311	10		311	10		311	Mhz

Table 5–47. Mini-LVDS Transmitter Timing Specification (Part 2 of 2)

Symbol	Conditions	-6 Speed Grade			-7 Speed Grade			-8 Speed Grade			Unit
		Min	Typ	Max	Min	Typ	Max	Min	Typ	Max	
Device operation in Mbps	×10	100		311	100		311	100		311	Mbps
	×8	80		311	80		311	80		311	Mbps
	×7	70		311	70		311	70		311	Mbps
	×4	40		311	40		311	40		311	Mbps
	×2	20		311	20		311	20		311	Mbps
	×1	10		311	10		311	10		311	Mbps
t_{DUTY}		45		55	45		55	45		55	%
TCCS				200			200			200	ps
Output jitter (peak to peak)				500			500			500	ps
t_{RISE}	20–80%			500			500			500	ps
t_{FALL}	80–20%			500			500			500	ps
t_{LOCK}				100			100			100	μs

In order to determine the transmitter timing requirements, mini-LVDS receiver timing requirements on the other end of the link must be taken into consideration. mini-LVDS receiver timing parameters are typically defined as t_{SU} and t_H requirements. Therefore, the transmitter timing parameter specifications are t_{CO} (minimum) and t_{CO} (maximum). Refer to [Figure 5–4](#) for the timing budget.

The AC timing requirements for mini-LVDS are shown in [Figure 5–6](#).

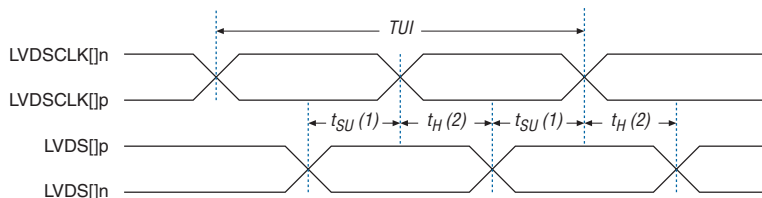
Figure 5–6. mini-LVDS Transmitter AC Timing Specification**Notes to Figure 5–6:**

- (1) The data setup time, t_{SU} , is $0.225 \times TUI$.
- (2) The data hold time, t_H , is $0.225 \times TUI$.

Timing Specifications

Tables 5–48 and 5–49 show the LVDS timing budget for Cyclone II devices. Cyclone II devices support LVDS receivers at data rates up to 805 Mbps and LVDS transmitters at data rates up to 640 Mbps.

Table 5–48. LVDS Transmitter Timing Specification (Part 1 of 2)

Symbol	Conditions	-6 Speed Grade				-7 Speed Grade				-8 Speed Grade				Unit
		Min	Typ	Max (1)	Max (2)	Min	Typ	Max (1)	Max (2)	Min	Typ	Max (1)	Max (2)	
f_{HCLK} (input clock frequency)	×10	10		320	320	10		275	320	10		155.5 (4)	320 (6)	Mhz
	×8	10		320	320	10		275	320	10		155.5 (4)	320 (6)	Mhz
	×7	10		320	320	10		275	320	10		155.5 (4)	320 (6)	Mhz
	×4	10		320	320	10		275	320	10		155.5 (4)	320 (6)	Mhz
	×2	10		320	320	10		275	320	10		155.5 (4)	320 (6)	Mhz
	×1	10		402.5	402.5	10		402.5	402.5	10		402.5 (8)	402.5 (8)	Mhz
HSIODR	×10	100		640	640	100		550	640	100		311 (5)	550 (7)	Mbps
	×8	80		640	640	80		550	640	80		311 (5)	550 (7)	Mbps
	×7	70		640	640	70		550	640	70		311 (5)	550 (7)	Mbps
	×4	40		640	640	40		550	640	40		311 (5)	550 (7)	Mbps
	×2	20		640	640	20		550	640	20		311 (5)	550 (7)	Mbps
	×1	10		402.5	402.5	10		402.5	402.5	10		402.5 (9)	402.5 (9)	Mbps
t_{DUTY}		45		55		45		55		45		55		%
					160				312.5				363.6	ps
TCCS (3)				200				200				200		ps
Output jitter (peak to peak)				500				500				550 (10)		ps
t_{RISE}	20–80%	150	200	250		150	200	250		150	200	250 (11)		ps

Table 5–48. LVDS Transmitter Timing Specification (Part 2 of 2)

Symbol	Conditions	-6 Speed Grade				-7 Speed Grade				-8 Speed Grade				Unit
		Min	Typ	Max (1)	Max (2)	Min	Typ	Max (1)	Max (2)	Min	Typ	Max (1)	Max (2)	
t_{FALL}	80–20%	150	200	250		150	200	250		150	200	250 (11)		ps
t_{LOCK}				100				100				100 (12)		μs

Notes to Table 5–48:

- (1) The maximum data rate that complies with duty cycle distortion of 45–55%.
- (2) The maximum data rate when taking duty cycle in absolute ps into consideration that may not comply with 45–55% duty cycle distortion. If the downstream receiver can handle duty cycle distortion beyond the 45–55% range, you may use the higher data rate values from this column. You can calculate the duty cycle distortion as a percentage using the absolute ps value. For example, for a data rate of 640 Mbps (UI = 1625 ps) and a t_{DUTY} of 250 ps, the duty cycle distortion is $\pm t_{DUTY}/(UI*2) * 100\% = \pm 250 \text{ ps}/(1625 * 2) * 100\% = \pm 7.7\%$, which gives you a duty cycle distortion of 42.3–57.7%.
- (3) The TCCS specification applies to the entire bank of LVDS as long as the SERDES logic is placed within the LAB adjacent to the output pins.
- (4) For extended temperature devices, the maximum input clock frequency for ×10 through ×2 modes is 137.5 MHz.
- (5) For extended temperature devices, the maximum data rate for ×10 through ×2 modes is 275 Mbps.
- (6) For extended temperature devices, the maximum input clock frequency for ×10 through ×2 modes is 200 MHz.
- (7) For extended temperature devices, the maximum data rate for ×10 through ×2 modes is 400 Mbps.
- (8) For extended temperature devices, the maximum input clock frequency for ×1 mode is 340 MHz.
- (9) For extended temperature devices, the maximum data rate for ×1 mode is 340 Mbps.
- (10) For extended temperature devices, the maximum output jitter (peak to peak) is 600 ps.
- (11) For extended temperature devices, the maximum t_{RISE} and t_{FALL} are 300 ps.
- (12) For extended temperature devices, the maximum lock time is 500 μs.

Symbol	Conditions	-6 Speed Grade			-7 Speed Grade			-8 Speed Grade			Unit
		Min	Typ	Max	Min	Typ	Max	Min	Typ	Max	
f_{HSCLK} (input clock frequency)	x10	10		402.5	10		320	10		320 (1)	Mhz
	x8	10		402.5	10		320	10		320 (1)	Mhz
	x7	10		402.5	10		320	10		320 (1)	Mhz
	x4	10		402.5	10		320	10		320 (1)	Mhz
	x2	10		402.5	10		320	10		320 (1)	Mhz
	x1	10		402.5	10		402.5	10		402.5 (3)	Mhz
HSIODR	x10	100		805	100		640	100		640 (2)	Mbps
	x8	80		805	80		640	80		640 (2)	Mbps
	x7	70		805	70		640	70		640 (2)	Mbps
	x4	40		805	40		640	40		640 (2)	Mbps
	x2	20		805	20		640	20		640 (2)	Mbps
	x1	10		402.5	10		402.5	10		402.5 (4)	Mbps
SW			300			400			400	ps	
Input jitter tolerance			500			500			550	ps	
t_{LOCK}			100			100			100 (5)	ps	

Notes to Table 5–49:

- (1) For extended temperature devices, the maximum input clock frequency for x10 through x2 modes is 275 MHz.
- (2) For extended temperature devices, the maximum data rate for x10 through x2 modes is 550 Mbps.
- (3) For extended temperature devices, the maximum input clock frequency for x1 mode is 340 MHz.
- (4) For extended temperature devices, the maximum data rate for x1 mode is 340 Mbps.
- (5) For extended temperature devices, the maximum lock time is 500 us.

JTAG Timing Specifications

Figure 5-7 shows the timing requirements for the JTAG signals.

Figure 5-7. Cyclone II JTAG Waveform

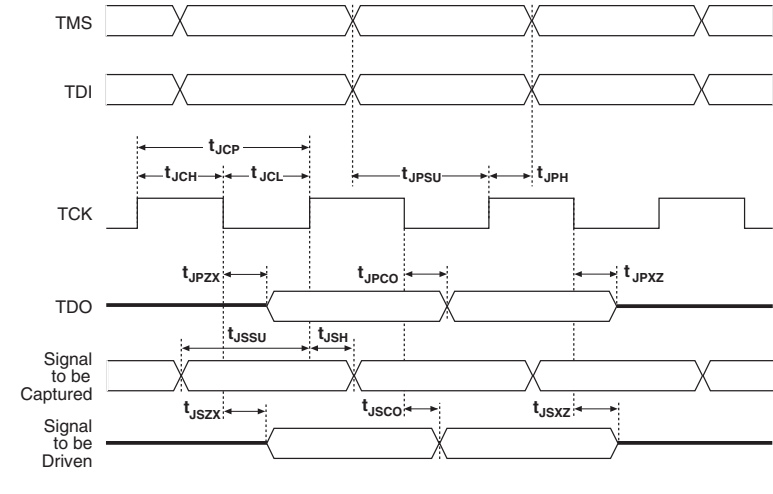

Table 5–50 shows the JTAG timing parameters and values for Cyclone II devices.

Table 5–50. Cyclone II JTAG Timing Parameters & Values

Symbol	Parameter	Min	Max	Unit
t_{JCP}	TCK clock period	40		ns
t_{JCH}	TCK clock high time	20		ns
t_{JCL}	TCK clock low time	20		ns
t_{JPSU}	JTAG port setup time (2)	5		ns
t_{JPH}	JTAG port hold time	10		ns
t_{JPCO}	JTAG port clock to output (2)		13	ns
t_{JPZX}	JTAG port high impedance to valid output (2)		13	ns
t_{JPXZ}	JTAG port valid output to high impedance (2)		13	ns
t_{JSSU}	Capture register setup time (2)	5		ns
t_{JSH}	Capture register hold time	10		ns
t_{JSCO}	Update register clock to output		25	ns
t_{JSZX}	Update register high impedance to valid output		25	ns
t_{JSXZ}	Update register valid output to high impedance		25	ns

Notes to Table 5–50:

- (1) This information is preliminary.
- (2) This specification is shown for 3.3-V LVTTTL/LVCMOS and 2.5-V LVTTTL/LVCMOS operation of the JTAG pins. For 1.8-V LVTTTL/LVCMOS and 1.5-V LVCMOS, the JTAG port and capture register clock setup time is 3 ns and port clock to output time is 15 ns.



Cyclone II devices must be within the first 17 devices in a JTAG chain. All of these devices have the same JTAG controller. If any of the Cyclone II devices are in the 18th or after they will fail configuration. This does not affect the SignalTap® II logic analyzer.



For more information on JTAG, see the *IEEE 1149.1 (JTAG) Boundary-Scan Testing for Cyclone II Devices* chapter in the *Cyclone II Handbook* and *Jam Programming & Test Language Specification*.

PLL Timing Specifications

Table 5–51 describes the Cyclone II PLL specifications when operating in both the commercial junction temperature range (0° to 85° C) and the industrial junction temperature range (-40 to 100° C). Follow the PLL specifications for –8 speed grade devices when operating in the industrial temperature range.

Symbol	Parameter	Min	Typ	Max	Unit
f_{IN}	Input clock frequency (-6 speed grade)	10		(4)	MHz
	Input clock frequency (-7 speed grade)	10		(4)	MHz
	Input clock frequency (-8 speed grade)	10		(4)	MHz
f_{INPFD}	PFD input frequency (-6 speed grade)	10		402.5	MHz
	PFD input frequency (-7 speed grade)	10		402.5	MHz
	PFD input frequency (-8 speed grade)	10		402.5	MHz
f_{INDUTY}	Input clock duty cycle	40		60	%
$t_{INJITTER}$ (5)	Input clock period jitter		200		ps
f_{OUT_EXT} (external clock output)	PLL output frequency (-6 speed grade)	10		(4)	MHz
	PLL output frequency (-7 speed grade)	10		(4)	MHz
	PLL output frequency (-8 speed grade)	10		(4)	MHz
f_{OUT} (to global clock)	PLL output frequency (-6 speed grade)	10		402.5	MHz
	PLL output frequency (-7 speed grade)	10		402.5	MHz
	PLL output frequency (-8 speed grade)	10		402.5	MHz
$t_{OUTDUTY}$	Duty cycle for external clock output (when set to 50%)	45		55	%
t_{JITTER} (p-p) (2)	Period jitter for external clock output $f_{OUT_EXT} > 100$ Mhz			300	ps
	$f_{OUT_EXT} \leq 100$ Mhz			30	mUI
t_{LOCK}	Time required to lock from end of device configuration			100 (6)	μ s

Table 5–51. PLL Specifications (Part 2 of 2) Note (1)					
Symbol	Parameter	Min	Typ	Max	Unit
f_{VCO} (3)	PLL internal VCO operating range	300		1,000	MHz
t_{ARESET}	Minimum pulse width on areset signal.	10			ns

Notes to Table 5–51:

- (1) These numbers are preliminary and pending silicon characterization.
- (2) The t_{JITTER} specification for the PLL[4 . . 1]_OUT pins are dependent on the I/O pins in its VCCIO bank, how many of them are switching outputs, how much they toggle, and whether or not they use programmable current strength.
- (3) If the design enables divide by 2, a 300- to 500-MHz internal VCO frequency is available.
- (4) This parameter is limited in Quartus II software by the I/O maximum frequency. The maximum I/O frequency is different for each I/O standard.
- (5) Cyclone II PLLs can track a spread-spectrum input clock that has an input jitter within ± 200 ps.
- (6) For extended temperature devices, the maximum lock time is 500 μ s.

Software

Cyclone™ II devices are supported by the Altera® Quartus® II design software, which provides a comprehensive environment for system-on-a-programmable-chip (SOPC) design. The Quartus II software includes HDL and schematic design entry, compilation and logic synthesis, full simulation and advanced timing analysis, SignalTap® II logic analyzer, and device configuration. See the *Quartus II Handbook* for more information on the Quartus II software features.

The free Quartus II Web Edition software, available at www.Altera.com, supports Microsoft Windows XP and Windows 2000. The full version of Quartus II software is available through the Altera subscription program. The full version of Quartus II software supports all Altera devices, is available for Windows XP, Windows 2000, Sun Solaris, and Red Hat Linux operating systems, and includes a free suite of popular IP MegaCore® functions for DSP applications and interfacing to external memory devices. Quartus II software and Quartus II Web Edition software support seamless integration with your favorite third party EDA tools.

Device Pin-Outs

Device pin-outs for Cyclone II devices are available on the Altera web site (www.altera.com). For more information contact Altera Applications.

Ordering Information

[Figure 6-1](#) describes the ordering codes for Cyclone II devices. For more information on a specific package, contact Altera Applications.

Figure 6–1. Cyclone II Device Packaging Ordering Information

