

On-Board Type (DC) EMI Suppression Filters (EMIFIL®)



Block Type EMIFIL® BNP/BNX Series

BNP Series

■ Features

1. The "EMIFIL" BNP002 incorporates through-type barrier layer capacitors and p circuits, allowing it to obtain significantly large insertion losses throughout an extremely wide frequency range from 15MHz up to 1GHz.
2. The cut-off frequency is designed to be at several MHz, which is ideal for eliminating noise from any circuit in which the signal frequency and the noise frequency are relatively close together.
3. Since all noise in plural signal lines can be eliminated by one filter block, the filter is extremely compact.
4. There are no connection routes in the current circuits, thus ensuring highly reliable performance.
5. Both the input/output terminals and the grounding terminal are aligned in the same direction, permitting fast and easy installation on any type of P.C. board.



BNP002-02/BNP004

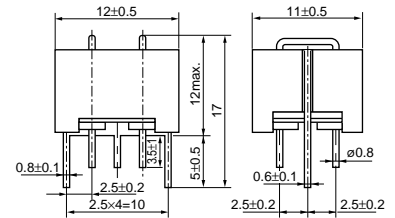

(in mm)



BNP002-03

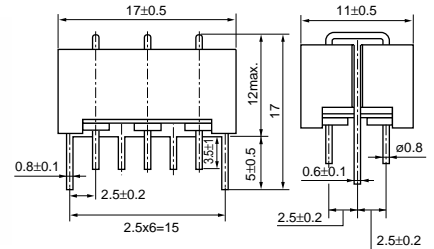

(in mm)

■ Applications

Noise elimination from signal lines and DC power sources in engine control units, digital equipment and computer terminals.

Part Number	Rated Voltage (Vdc)	Withstand Voltage (Vdc)	Rated Current (A)	Insulation Resistance (min.) (M ohm)	DC Resistance (max.) (ohm)	Insertion Loss	Number of Circuit
BNP002-02	50	300	10	1000	0.05 (20 to 25°C)	20MHz to 500MHz:40dB min.(20 to 25°C)	2
BNP002-03	50	300	10	1000	0.05 (20 to 25°C)	20MHz to 500MHz:40dB min.(20 to 25°C)	3
BNP004-02	50	125	10	1000	0.05 (20 to 25°C)	300MHz to 1000MHz:40dB min.(20 to 25°C)	2

Operating Temperature Range : -40°C to 100°C

■ Equivalent Circuit

BNP002-02/BNP004

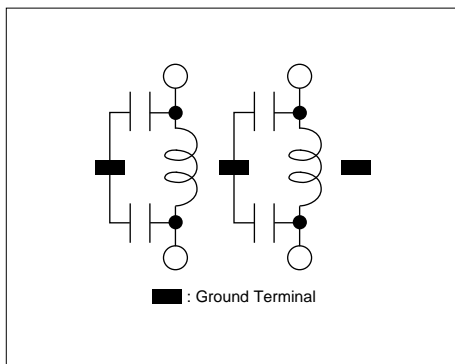

BNP002-03

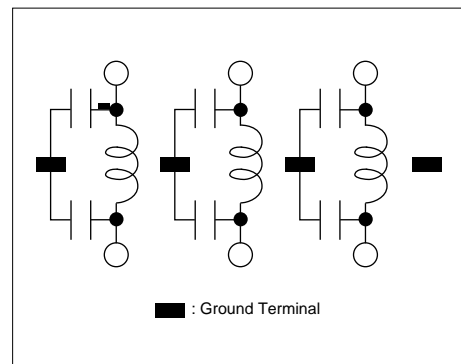

Continued from the preceding page.

■ Insertion Loss Characteristics (Typical)

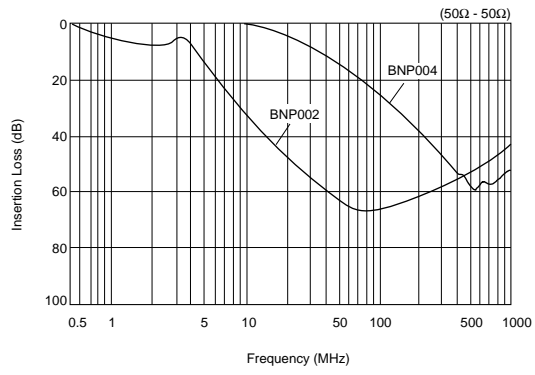

BNX Series

Features

1. The "EMIFIL" BNX002 incorporates a through-type barrier layer capacitor and a four-terminal capacitor which are interconnected. This combination enables the BNX002 to achieve a significantly large insertion loss throughout the extremely wide frequency range of 0.5MHz to 1GHz which covers the AM and UHF-TV broadcast frequency bands.
2. The filter is extremely compact since only one filter block is needed to completely eliminate noise from both the positive and negative lines.
3. There are no connection routes in the current circuits, thus ensuring highly reliable performance.
4. Both the input/output terminals and the grounding terminal are aligned in the same direction, permitting fast and easy installation on any type of P.C. board.
5. BNX003-01 features high dielectric constant, that is the rated voltage 150V.



BNX002/BNX003

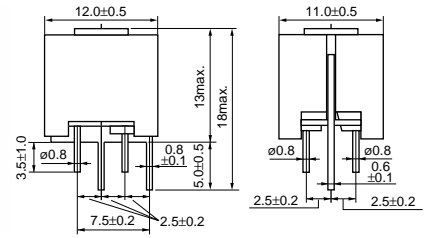

(in mm)



BNX005

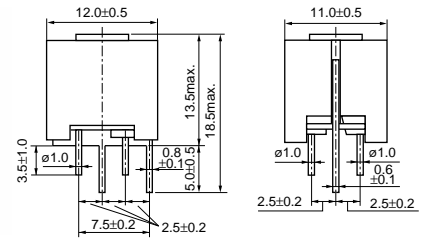

(in mm)

Applications

Noise elimination from DC power sources in a variety of switching power sources, engine control units, digital equipment and computer terminals.

Part Number	Rated Voltage (Vdc)	Withstand Voltage (Vdc)	Rated Current (A)	Insulation Resistance (min.) (M ohm)	Insertion Loss
BNX002-01	50	125	10	100	1MHz to 1GHz:40dB min.(20 to 25°C line impedance=50 ohm)
BNX003-01	150	375	10	100	5MHz to 1GHz:40dB min.(20 to 25°C line impedance=50 ohm)
BNX005-01	50	125	15	100	1MHz to 1GHz:40dB min.(20 to 25°C line impedance=50 ohm)

Operating Temperature Range : -30°C to 85°C

Equivalent Circuit

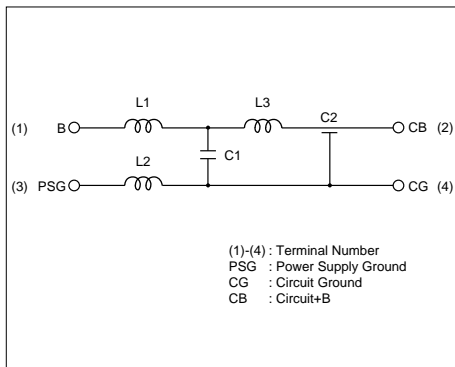

Insertion Loss Characteristics (Typical)

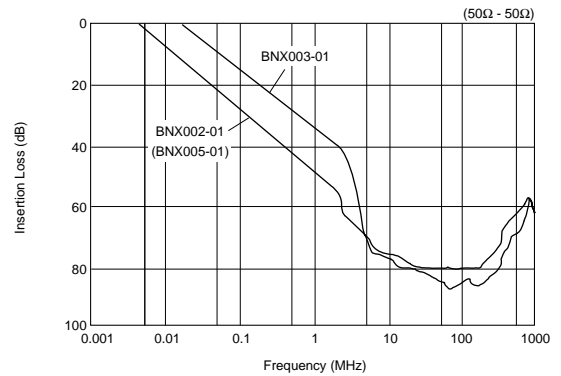

Noise Suppression Effect of BNX Series

■ Suppression of DC Side Ripple of the Switching Power Supply

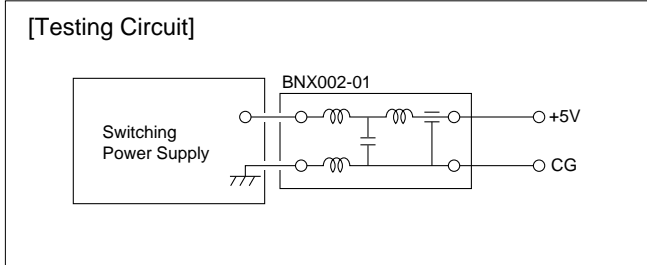

Type of Filter	EMI Suppression Effect	Description
When BNX002 is not used	<p>+5.0V → 50μs/div 0.2V/div</p>	High frequency noise, max. 0.5V, can be seen.
When BNX002 is used	<p>+5.0V → 50μs/div 0.2V/div</p>	Noise can be almost suppressed by BNX002.