

PACE1750AE SINGLE CHIP, 40MHz, ENHANCED CMOS 16-BIT PROCESSOR

FEATURES

- Implements the MIL-STD-1750A Instruction Set Architecture
- Single Chip PACE Technology™ CMOS 16-Bit Processor with 32 and 48-Bit Floating Point Arithmetic
- Form-Fit-Functionally Compatible with the P1750A
- DAIS Instruction Mix Execution Performance Including Floating Point Arithmetic
 - 2.7 MIPS at 30 MHz
 - 3.1 MIPS at 35 MHz
 - 3.6 MIPS at 40 MHz
- Conventional Integer Processing Mix Performance
 - 5.0 MIPS at 40 MHz
- Power BIF Instructions Allow for High Throughput Implementations of Transcendental Functions, Navigational Algorithms and DSP Functions
 - Inner Dot Product instruction for 3X3, 16 Bit Registers in 150ns (2 clocks per Multiply/Accumulate step) with 32 Bits Result
 - Multiply/Accumulate Instructions for 32 Bit Registers is 200ns at 40MHz (8 clocks), with 48 Bit Result
 - Parameteric Memory Inner-Dot Products for Matrix Computations up to 64K
 - Fast Polynomial expansion algorithms
 - Fast context switching with instruction to block move up to 16 new mapping memory page registers

- 30, 35 and 40 MHz Operation over the Military Temperature Range
- Extensive Error and Fault Management and Interrupt Capability
- 26 User Accessible Registers
- Single 5V ± 10% Power Supply
- Power Dissipation over Military Temperature Range
 - <0.5 watts at 30 MHz
 - <0.75 watts at 35 MHz
 - <1.0 watts at 40 MHz

- TTL Signal Level Compatible Inputs and Outputs
- Multiprocessor and Co-processor Capability
- Two programmable Timers

Available in:

- 68-Pin Pin Grid Array (PGA)
- 68-Lead Quad Pack (Leaded Chip Carrier)

provides an escape mechanism which allows user-defined instructions, using a coprocessor.

The chip includes an array of real time application support resources, such as 2 programmable timers, a complete interrupt controller supporting 16 levels of prioritized internal and external interrupts, and a faults and exceptions handler controlling internally and externally generated faults.

The microprocessor achieves very high throughput of 3.6 MIPS for a standard real time integer/floating point instruction mix at a 40 MHz clock. It executes Integer Add in 0.1 μ s, Integer Multiply in 0.1 μ s, Floating Point Add in 0.45 μ s, and Floating Point Multiply in 0.225 μ s, for register operands at a 40 MHz clock speed.

The PACE1750AE uses a single multiplexed 16-bit parallel bus. Status signals are provided to determine whether the processor is in the memory or I/O bus cycle, reading and writing, and whether the bus cycle is for data or instructions.

GENERAL DESCRIPTION

The PACE1750AE is a general purpose, single chip, 16-bit CMOS microprocessor designed for high performance floating point and integer arithmetic, with extensive real time environment support. It offers a variety of data types, including bits, bytes, 16-bit and 32-bit integers, and 32-bit and 48-bit floating point numbers. It provides 13 addressing modes, including direct, indirect, indexed, based, based indexed and immediate long and short, and it can access 2 MWords of segmented memory space (64 KWords segments).

The PACE1750AE offers a well-rounded instruction set with 130 instruction types, including a comprehensive integer, floating point, integer-to-floating point and floating point-to-integer set, a variety of stack manipulation instructions, high level language support instructions such as Compare Between Bounds and Loop Control Instructions. It also offers some unique instructions such as vectored I/O, supports executive and user modes, and

DIFFERENCES BETWEEN THE PACE1757A AND PACE1757AE

The PACE1757AE achieves a 41% boost in performance (in clock cycles) over the PACE1757A. This reduction in clocks per instruction is because of three architectural enhancements:

- 1) The inclusion of a 24 x 24 Multiply Accumulate (MAC) array.
- 2) A reduction in non-bus cycles to 2 clocks (bus cycles remain at 4 clocks to maintain full compatibility with CPU's peripheral chips).
- 3) Branch calculation logic.

The table below shows how the MAC improves all multiply operations — both integer and floating point — by 477% to 760%.

Instruction	PACE1750AE		PACE1750A		Gain #Clocks (%)
	Clocks	Execution Time (40 MHz)	Clocks	Execution Time (40 MHz)	
Integer Add/Sub	4	100ns	4	100ns	—
Double Precision Integer Add/Sub	6	150ns	9	225ns	50
Integer Multiply	4	100ns	23	575ns	575
Double Precision Integer Add/Sub	9	225ns	69	1725ns	760
Floating Add/Sub	18	450ns	28	700ns	55
Extended Floating Add/Sub	34	850ns	51	1225ns	50
Floating Multiply	9	225ns	43	1075ns	477
Extended Floating Point Multiply	17	425ns	96	2400ns	564
Branch (Taken)	8	200ns	12	300ns	50
Branch (Not Taken)	4	100ns	4	100ns	—
Fit'g' Point Polynomial Step (Mul+Add/Sub)	27	675ns	71	1775ns	263
Ext Fit'g' Point Polynomial Step (Mul/Sub)	51	1275ns	147	3675ns	2400
DAIS Mix (MIPS)	—	3.56	—	2.52	41/59

PACE1757AE BUILT IN FUNCTIONS

A core set of additional instructions have been included in the PACE1757AE. These instructions utilize the Built In Function (BIF) opcode space. The objective of these new opcodes is to enhance the performance of the PACE in critical application areas such as navigation, DSP, transcendentals and other LINPAK and matrix type instructions. Below is a list of the BIFs and their execution times (N = the number of elements in the vector being processed).

Instruction	Mnemonic	Address Mode	Number of Clocks	Notes
Memory Parametric Dot Product—Single	VDPS	4F3(RA)	10 + 8 • N	Interruptable
Memory Parametric Dot Product—Double	VDPD	4F1(RA)	10+16 • N	Interruptable
3 x 3 Register Dot Product	R3DP	4F03	6	
Double Precision Multiply Accumulate	MACD	4F02	8	
Polynomial	POLY	4F06	7 • N - 2	
Clear Accumulator	CLAC	4F00	4	
Store Accumulator (32-Bit)	STA	4F08	7	
Store Accumulator (48-Bit)	STAL	4F04	11	
Load Accumulator (32-Bit)	LAC	4F05	9	
Load Accumulator Long (48-Bit)	LACL	4F07	9	
Move MMU Page Block	MMPG	4F0F	16+8 • N	Privileged
Load Timer A Reset Register	LTAR	4F0D	4	
Load Timer B Reset Register	LTBR	4F0E	4	

ABSOLUTE MAXIMUM RATINGS¹

Supply Voltage Range	-0.5V to +7.0V
Input Voltage Range	-0.5V to $V_{CC} + 0.5V$
Storage Temperature Range	-65°C to +150°C
Input Current Range	-30mA to +5mA
Voltage applied to Inputs	-0.5V to $V_{CC} + 0.5V$
Current applied to Output ³	150mA
Maximum Power Dissipation ²	1.5W

Notes

1. Stresses above the absolute maximum rating may cause permanent damage to the device. Extended operation at the maximum levels may degrade performance and affect reliability.
2. Must withstand the added power dissipation due to short circuit test e.g., I_{OS} .
3. Duration 1 second or less.

RECOMMENDED OPERATING CONDITIONS

Case Temperature	GND	V_{CC}
-55°C to +125°C	0	4.5V to +5.5V

DC ELECTRICAL SPECIFICATIONS (Over recommended operating conditions)

Symbol	Parameter	Min	Max	Unit	Conditions ¹	
V _{IH}	Input HIGH Level Voltage	2.0	V _{CC} + 0.5	V		
V _{IL}	Input LOW Level Voltage ²	-0.5	0.8	V		
V _{CD}	Input Clamp Diode Voltage		-1.2	V	V _{CC} = 4.5V, I _{IN} = -18mA	
V _{OH}	Output HIGH Level Voltage	2.4		V	V _{CC} = 4.5V, I _{OH} = -8.0mA	
		V _{CC} - 0.2		V	V _{CC} = 4.5V, I _{OH} = -300μA	
V _{OL}	Output LOW Level Voltage		0.5	V	V _{CC} = 4.5V, I _{OL} = 8.0mA	
			0.2	V	V _{CC} = 4.5V, I _{OL} = 300μA	
I _{IH1}	Input HIGH Level Current, except I _{B0} - I _{B15} , BUS BUSY, BUS LOCK		10	μA	V _{IN} = V _{CC} , V _{CC} = 5.5V	
I _{IH2}	Input HIGH Level Current, I _{B0} - I _{B15} , BUS BUSY, BUS LOCK		50	μA	V _{IN} = V _{CC} , V _{CC} = 5.5V	
I _{IL1}	Input LOW Level Current, except I _{B0} - I _{B15} , BUS BUSY, BUS LOCK		-10	μA	V _{IN} = GND, V _{CC} = 5.5V	
I _{IL2}	Input LOW Level Current, I _{B0} - I _{B15} , BUS BUSY, BUS LOCK		-50	μA	V _{IN} = GND, V _{CC} = 5.5V	
I _{OZH}	Output Three-State Current		50	μA	V _{OUT} = 2.4V, V _{CC} = 5.5V	
I _{OZL}	Output Three-State Current		-50	μA	V _{OUT} = 0.5V, V _{CC} = 5.5V	
I _{CCQC}	Quiescent Power Supply Current (CMOS Input Levels)		20	mA	V _{IN} < 0.2V or < V _{CC} - 0.2V, f = 0MHz, Outputs Open, V _{CC} = 5.5V	
I _{CCQT}	Quiescent Power Supply Current (TTL Input Levels)		50	mA	V _{IN} < 3.4V, f = 0MHz, Outputs Open, V _{CC} = 5.5V	
I _{CCD}	Dynamic Power Supply Current	30MHz		70	mA	V _{CC} = 0V to V _{CC} , tr = tf = 2.5 ns, Outputs Open, V _{CC} = 5.5V
		35MHz		85	mA	
		40MHz		100	mA	
I _{OS}	Output Short Circuit Current ³	-25		mA	V _{OUT} = GND, V _{CC} = 5.5V	
C _{IN}	Input Capacitance		10	pF		
C _{OUT}	Output Capacitance		15	pF		
C _{I/O}	Bi-directional Capacitance		15	pF		

Notes

1. 4.5V ≤ V_{CC} ≤ 5.5V, -55°C ≤ T_C ≤ +125°C. Unless otherwise specified, testing shall be conducted at worst-case conditions.
2. V_{IL} = -3.0V for pulse widths less than or equal to 20ns.
3. Duration of the short should not exceed one second; only one output may be shorted at a time.

SIGNAL PROPAGATION DELAYS^{1,2}

Symbol	Parameter	30 MHz		35MHz		40 MHz		Unit
		Min	Max	Min	Max	Min	Max	
t _{C(BR)L}	BUS REQ		25		22		22	ns
t _{C(BR)H}	BUS REQ		25		22		22	ns
t _{BGV(C)}	BUS GNT setup	5		5		5		ns
t _{C(BG)X}	BUS GNT hold	5		5		5		ns
t _{C(BB)L}	BUS BUSY LOW		24		22		20	ns
t _{C(BB)H}	BUS BUSY HIGH		24		18		20	ns
t _{BBV(C)}	BUS BUSY setup	5		5		5		ns
t _{C(BB)X}	BUS BUSY hold	5		5		5		ns
t _{C(BL)L}	BUS LOCK LOW		25		23		21	ns
t _{C(BL)H}	BUS LOCK HIGH		25		19		17	ns
t _{BLV(C)}	BUS LOCK setup	5		5		5		ns
t _{C(BL)X (IN)}	BUS LOCK hold	5		5		5		ns
t _{C(ST)V}	D/I Status, AS ₀ -AS ₃ , AK ₀ -AK ₃ M/I/O, R/W		20 25		20 23		20 20	ns ns
t _{C(ST)X}	M/I/O, R/W, D/I Status, AS ₀ -AS ₃ , AK ₀ -AK ₃	0		0		0		ns
t _{C(SA)H}	STRBA HIGH		17		16		16	ns
t _{C(SA)L}	STRBA LOW		17		16		16	ns
t _{SAL(IBA)X}	Address hold from STRBA LOW	5		5		5		ns
t _{RAV(C)}	RDYA setup	5		5		5		ns
t _{C(RA)X}	RDYA hold	5		5		5		ns
t _{C(SDW)L}	STRBD LOW write		17		16		14	ns
t _{C(SD)H}	STRBD HIGH		17		16		14	ns
t _{FC(SDR)L}	STRBD LOW read		17		16		14	ns
t _{(SDR)HIBDX}	STRBD HIGH	0		0		0		ns
t _{SDWH(IBD)X}	STRBD HIGH	25		21		17		ns
t _{SDL(SD)H}	STRBD write	36		23		20		ns
t _{RDV(C)}	RDYD setup	5		5		5		ns
t _{C(RD)X}	RDYD hold	5		5		5		ns
t _{C(IBA)V}	IB ₀ -IB ₁₅		25		23		20	ns
t _{FC(IBA)V}	IB ₀ -IB ₁₅	0		0		0		ns
t _{IBDRV(C)}	IB ₀ -IB ₁₅ setup	5		5		5		ns
t _{C(IBD)X}	IB ₀ -IB ₁₅ hold (read)	6		5		5		ns
t _{C(IBD)X}	Data valid out (write)	0		0		0		ns

SIGNAL PROPAGATION DELAYS^{1,2} (continued)

Symbol	Parameter	30 MHz		35 MHz		40 MHz		Unit
		Min	Max	Min	Max	Min	Max	
t _{FC} (IBD)V	IB ₀ -IB ₁₅		25		23		20	ns
t _C (SNW)	SNEW		25		24		22	ns
t _{FC} (TGO)	TRIGO RST		25		24		22	ns
t _{RSTL} (DMA ENL)	DMA enable		25		33		30	ns
t _C (DME)	DMA enable		25		33		30	ns
t _{FC} (NPU)	Normal power up		35		33		30	ns
t _C (ER)	Clock to major error unrecoverable		50		47		45	ns
t _{RSTL} (NPU)	RESET		40		35		30	ns
t _{REQV} (C)	Console request	0		0		0		ns
t _C (REQ)X	Console request	10		10		10		ns
t _{FV} (BB)H	Level sensitive faults	5		5		5		ns
t _{BBH} (FX)	Level sensitive faults	5		5		5		ns
t _{IRV} (C)	IOL ₁₋₂ INT user interrupt (0-5) setup	0		0		0		ns
t _C (IR)X	Power down interrupt level sensitive hold	10		10		10		ns
t _{RSTL} (t _{RSTH})	Reset pulse width	20		18		15		ns
t _C (XX)Z	Clock to three-state		17		15		13	ns
t _t (F), t _t (1)	Edge sensitive pulse width	5		5		5		ns
t _r , t _f	Clock rise and fall		5		5		5	ns

Notes

1. 4.5V ≤ V_{CC} ≤ 5.5V, -55°C ≤ T_C ≤ +125°C. Unless otherwise specified, testing shall be conducted at worst-case conditions.
2. All timing parameters are composed of Three elements. The first "t" stands for timing. The second represents the "from" signal. The third in parentheses indicates "to" signal. When the CPU clock is one of the signal elements, either the rising edge "C" or the falling edge "FC" is referenced. When other elements are used, an additional suffix indicates the final logic level of the signal. "L" - low level, "H" - high level, "V" - valid, "Z" - high impedance, "X" - don't care, "LH" - low to high, "ZH" - high impedance to high, "R" - read cycle, and "W" - write cycle.

MINIMUM WRITE BUS CYCLE TIMING DIAGRAM

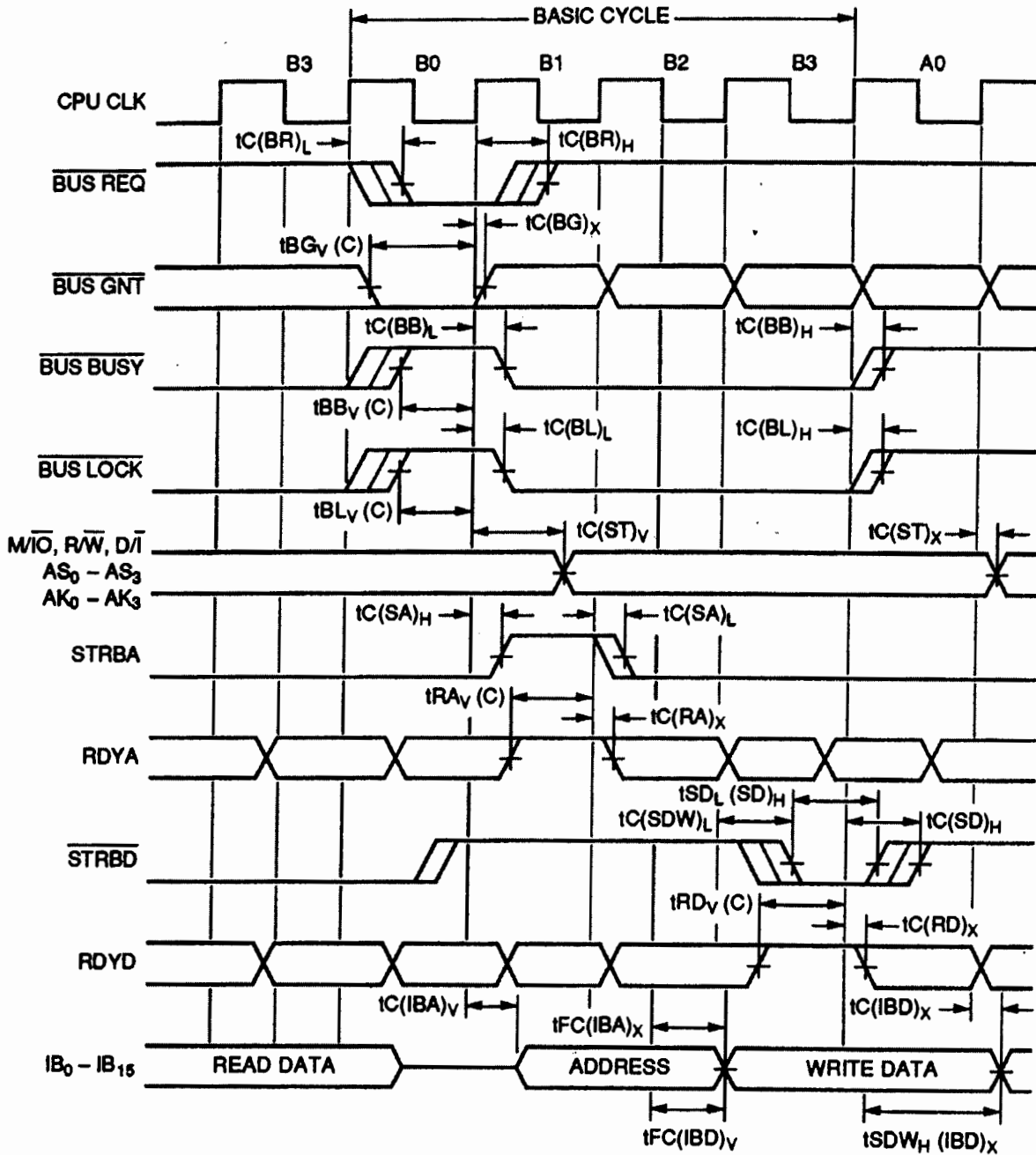

Note:
All time measurements on active signals relate to the 1.5 volt level.

MINIMUM READ BUS CYCLE TIMING DIAGRAM

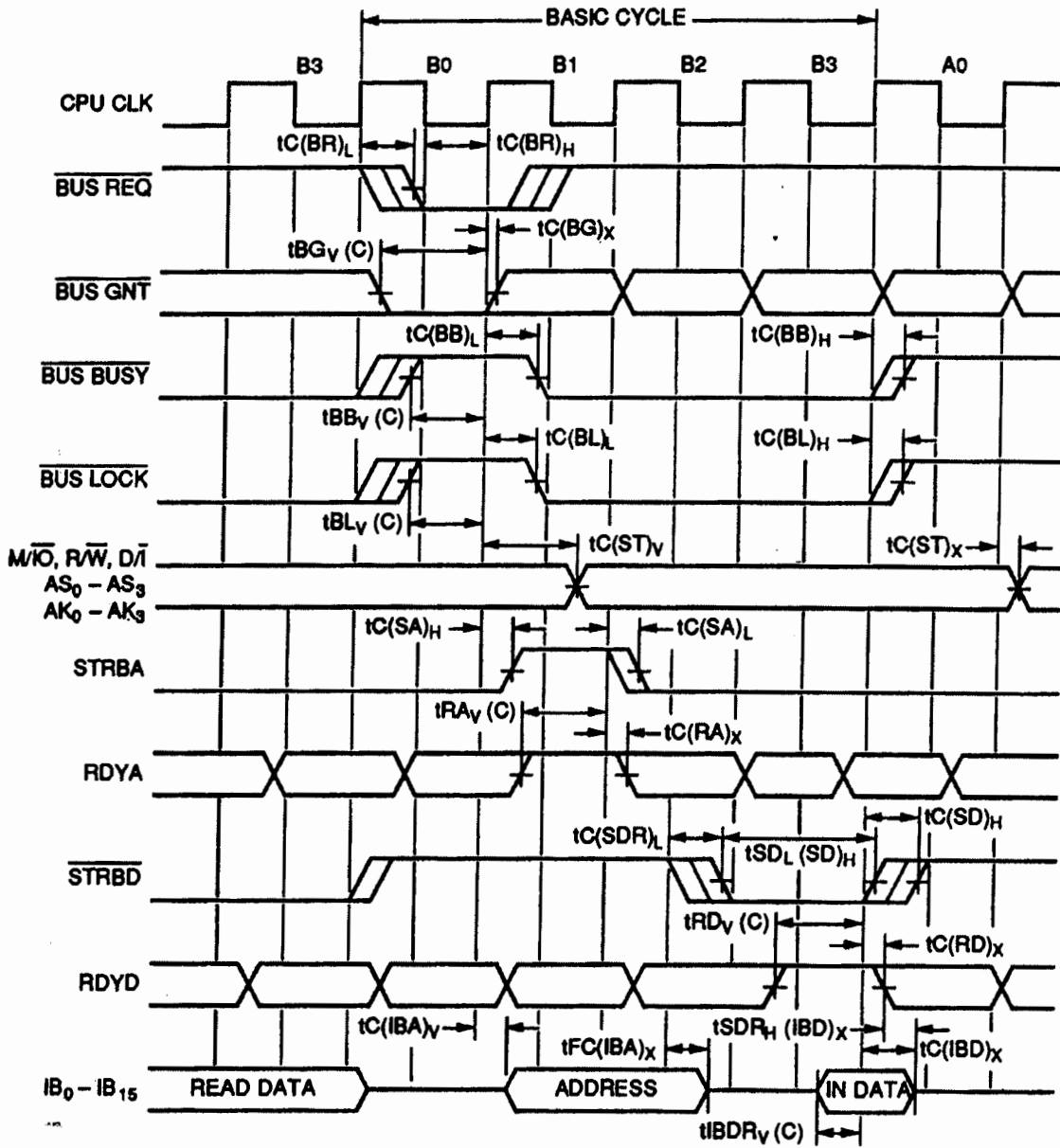

Note:
All time measurements on active signals relate to the 1.5 volt level.

MINIMUM WRITE BUS CYCLE, FOLLOWED BY A NON-BUS CYCLE, TIMING DIAGRAM

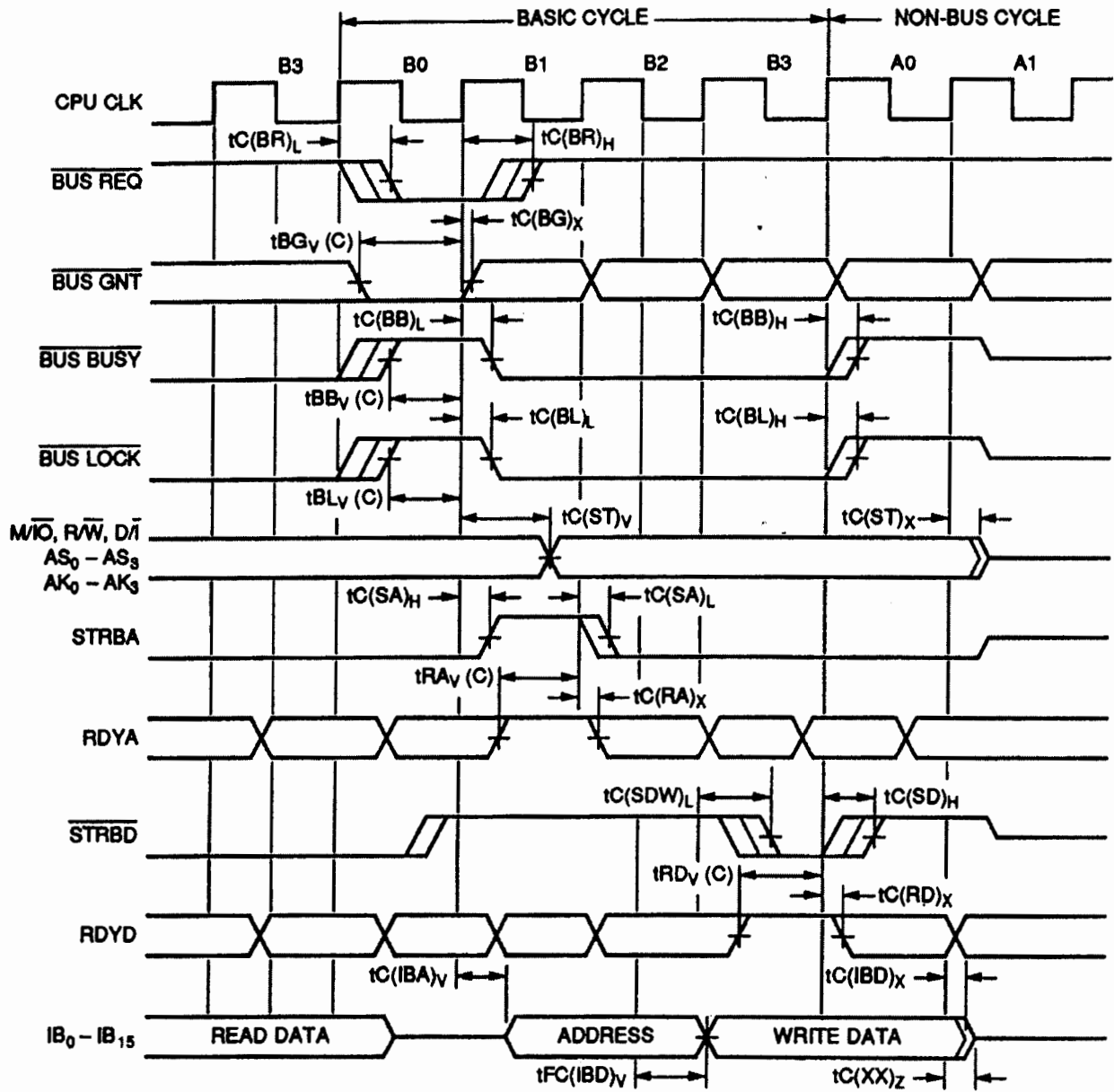

Note:
All time measurements on active signals relate to the 1.5 volt level.

TRIGO RST DISCRETE TIMING DIAGRAM

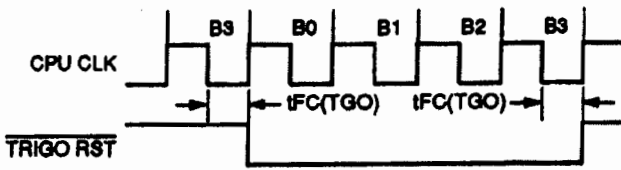

DMA EN DISCRETE TIMING DIAGRAM

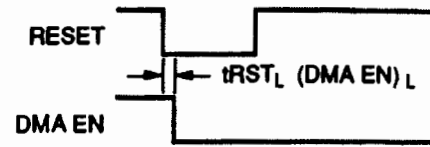

NORMAL POWER UP DISCRETE TIMING DIAGRAM

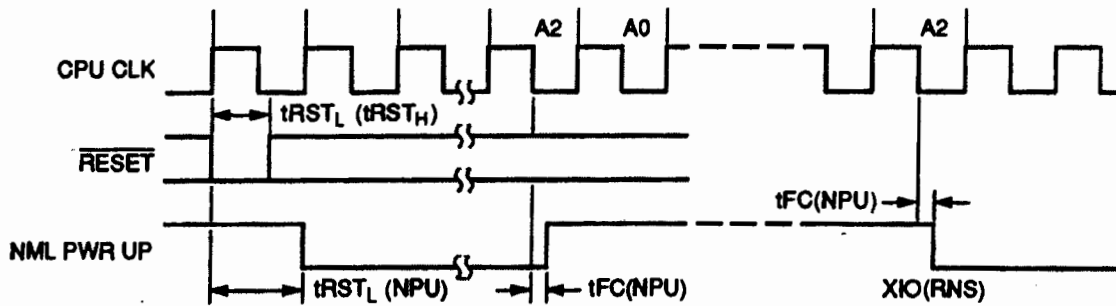

XIO OPERATIONS

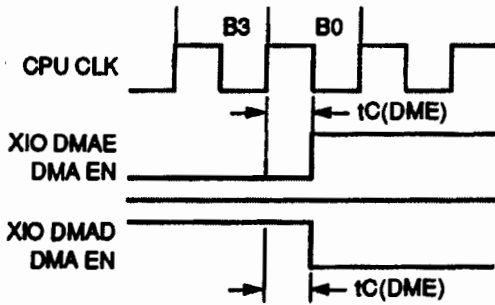

SNEW DISCRETE TIMING DIAGRAM

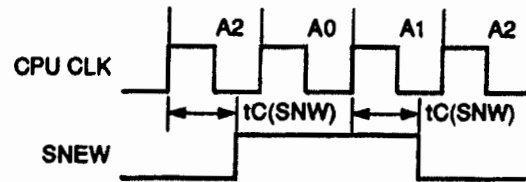

Note:
All time measurements on active signals relate to the 1.5 volt level.

EXTERNAL FAULTS AND INTERRUPTS TIMING DIAGRAM

Edge-sensitive interrupts and faults (SYSFLT₀, SYSFLT₁) min. pulse width

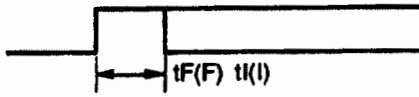

Level-sensitive interrupts

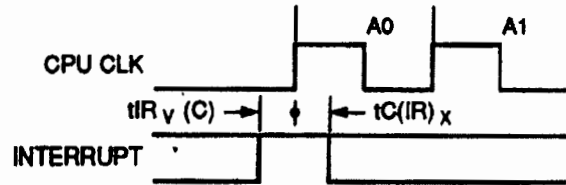

Note:
 $tC(IR)_X$ max = 36 clocks

Level-sensitive faults

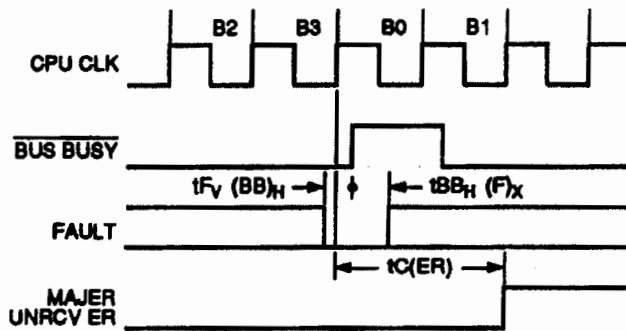

Note:
 All time measurements on active signals relate to the 1.5 volt level.

CON REQ

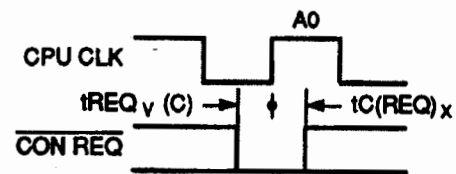

BUS ACQUISITION

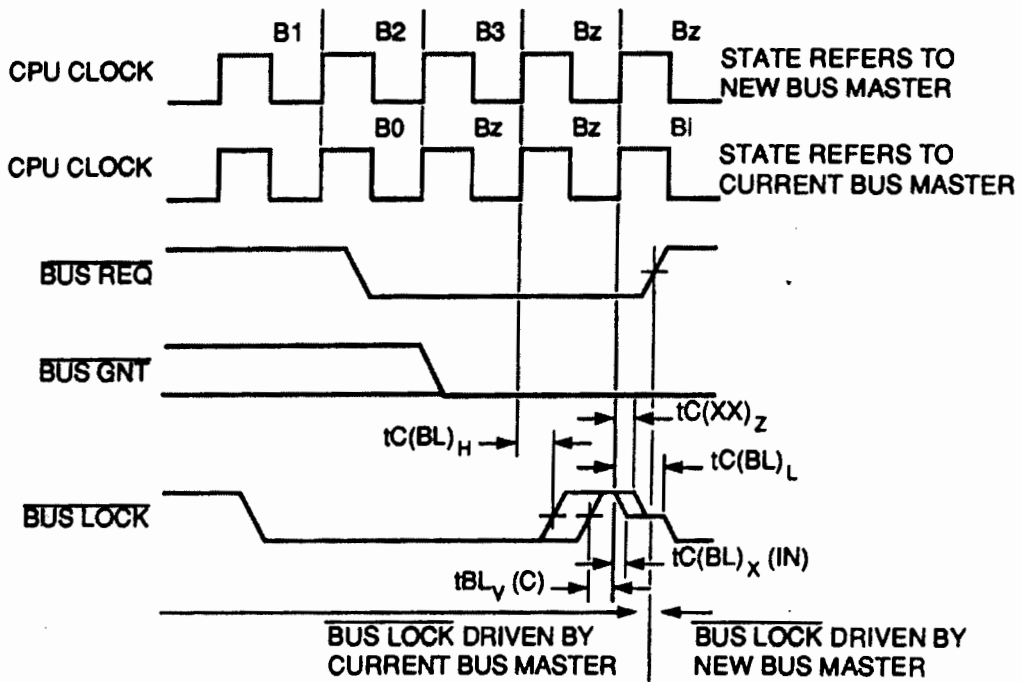

Note:
 A CPU contending for the BUS, will assert the BUS REQ line, and will acquire it when BUS GNT is asserted and the BUS is not locked (BUS LOCK is high).

SWITCHING TIME TEST CIRCUITS

Standard Output (Non-Three-State)

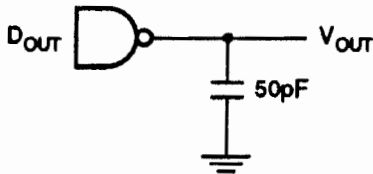

Three-State

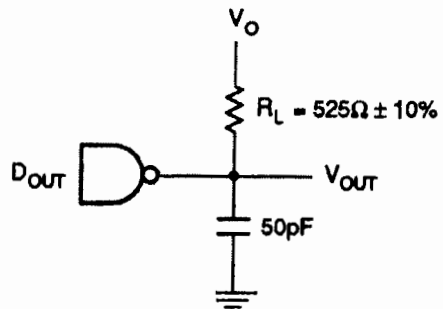

Note:
 All time measurements on active signals relate to the 1.5 volt level.

Parameter	V0	VMEA
t_{PLZ}	$\geq 3V$	0.5V
t_{PHZ}	0V	$V_{CC} - 0.5V$
t_{PXL}	$V_{CC}/2$	1.5V
t_{PXH}	$V_{CC}/2$	1.5V

SIGNAL DESCRIPTIONS**CLOCKS AND EXTERNAL REQUESTS**

Mnemonic	Name	Description
CPU CLK	CPU clock	A single phase input clock signal (0-40 MHz, 40 percent to 60 percent duty cycle).
TIMER CLK	Timer clock	A 100 kHz input that, after synchronization with CPU CLK provides the clock for timer A and timer B. If timers are used, the CPU CLK signal frequency must be > 300 kHz.
<u>RESET</u>	Reset	An active low input that initializes the device.
<u>CON REQ</u>	Console request	An active low input that initiates console operations after completion of the current instruction.

INTERRUPT INPUTS

Mnemonic	Name	Description
PWRDN INT	Power down interrupt	An interrupt request input that cannot be masked or disabled. This signal is active on the positive going edge or the high level, according to the interrupt mode bit in the configuration register.
USR ₀ INT - USR ₅ INT	User interrupt	Interrupt request input signals that are active on the positive going edge or the high level, according to the interrupt mode bit in the configuration register
IOL ₁ INT IOL ₂ INT	I/O level interrupts	Active high interrupt request inputs that can be used to expand the number of user interrupts.

FAULTS

Mnemonic	Name	Description
<u>MEM PRT ER</u>	Memory protect error	An active low input generated by the MMU or BPU, or both and sampled by the <u>BUS BUSY</u> signal into the Fault Register (bit 0 CPU bus cycle, bit 1 if non-CPU bus cycle).
<u>MEM PAR ER</u>	Memory parity error	An active low input sampled by the <u>BUS BUSY</u> signal into bit 2 of the fault register.
<u>EXT ADR ER</u>	External address error	An active low input sampled by the <u>BUS BUSY</u> signal into the Fault register (bit 5 or 8), depending on the cycle (memory or I/O).
SYSFLT ₀ SYSFLT ₁	System fault ₀ , System fault ₁ ,	Asynchronous, positive edge-sensitive inputs that set bit 7 (SYSFLT ₀) or bits 13 and 15 (SYSFLT ₁) in the Fault register.

ERROR CONTROL

Mnemonic	Name	Description
UNRCV ER	Unrecoverable error	An active high output that indicates the occurrence of an error classified as unrecoverable.
MAJ ER	Major error	An active high output that indicates the occurrence of an error classified as major.

SIGNAL DESCRIPTIONS (Continued)

BUS CONTROL

Mnemonic	Name	Description
D/I	Data or instruction	An output signal that indicates whether the current bus cycle access is for Data (high) or Instruction (low). It is three-state during bus cycles not assigned to this CPU. This line can be used as an additional memory address bit for systems that require separate data and program memory.
R/W	Read or write	An output signal that indicates direction of data flow with respect to the current bus master. A high indicates a read or input operation and a low indicates a write or output operation. The signal is three-state during bus cycles not assigned to this CPU.
M/I/O	Memory or I/O	An output signal that indicates whether the current bus cycle is memory (high) or I/O (low). This signal is three-state during bus cycles not assigned to this CPU.
STRBA	Address strobe	An active high output that can be used to externally latch the memory or I/O address at the high-to-low transition of the strobe. The signal is three-state during bus cycles not assigned to this CPU.
RDYA	Address ready	An active high input that can be used to extend the address phase of a bus cycle. When RDYA is not active wait states are inserted by the device to accommodate slower memory or I/O devices.
STRBD	Data strobe	An active low output that can be used to strobe data in memory and XIO cycles. This signal is three-state during bus cycles not assigned to this CPU.
RDYD	Data ready	An active high input that extends the data phase of a bus cycle. When RDYD is not active, wait states are inserted by the device to accommodate slower memory or I/O devices.

INFORMATION BUS

Mnemonic	Name	Description
IB ₀ - IB ₁₅	Information bus	A bidirectional time-multiplexed address/data bus that is three-state during bus cycles not assigned to this CPU. IB ₀ is the most significant bit.

STATUS BUS

Mnemonic	Name	Description
AK ₀ - AK ₃	Access key	Outputs used to match the access lock in the MMU for memory accesses (a mismatch will cause the MMU to pull the MEM_PRT_ER signal low), and also indicates processor state (PS). Privileged instructions can be executed with PS = 0 only. These signals are three-state during bus cycles not assigned to this CPU.
AS ₀ - AS ₃	Address state	Outputs that select the page register group in the MMU. It is three-state during bus cycles not assigned to this CPU. [These outputs together with D/I] can be used to expand the device direct addressing space to 4 MBytes, in a nonprotected mode (no MMU)]. However, using this addressing mode may produce situations not specified in MIL-STD-1750.

SIGNAL DESCRIPTIONS (Continued)**BUS ARBITRATION**

Mnemonic	Name	Description
<u>BUS REQ</u>	Bus request	An active low output that indicates the CPU requires the bus. It becomes inactive when the CPU has acquired the bus and started the bus cycle.
<u>BUS GNT</u>	Bus grant	An active low input from an external arbiter that indicates the CPU currently has the highest priority bus request. If the bus is not used and not locked, the CPU may begin a bus cycle, commencing with the next CPU clock. A high level will hold the CPU in HI-Z state (Bz), three-stating the IB bus status lines (D/L, R/W, M/IQ), strobes (STRBA, STRBD), and all the other lines that go three-state when this CPU does not have the bus.
<u>BUS BUSY</u>	Bus busy	An active low, bidirectional signal used to establish the beginning and end of a bus cycle. The trailing edge (low-to-high transition) is used for sampling bits into the fault register. It is three-state in bus cycles not assigned to this CPU. However, the CPU monitors the <u>BUS BUSY</u> line for latching non-CPU bus cycle faults into the fault register.
<u>BUS LOCK</u>	Bus lock	An active low, bi-directional signal used to lock the bus for successive bus cycles. During non-locked bus cycles, the <u>BUS LOCK</u> signal mimics the <u>BUS BUSY</u> signal. It is three-state during bus cycles not assigned to this CPU. The following instructions will lock the bus: INCM, DECM, SB, RB, TSB, SRM, STUB and STLb.

DISCRETE CONTROL

Mnemonic	Name	Description
DMA EN	Direct memory Access enable	An active high output that indicates the DMA is enabled. It is disabled when the CPU is initialized (reset) and can be enabled or disabled under program control (I/O commands DMAE, DMAD).
NML PWRUP	Normal power up	An active high output that is set when the CPU has successfully completed the built-in self test in the initialization sequence. It can be reset by the I/O command RNS.
SNEW	Start new	An active high output that indicates a new instruction is about to start executing in the next cycle.
<u>TRIGO_RST</u>	Trigger-go reset	An active low discrete output. This signal can be pulsed low under program control I/O address 400B (Hex) and is automatically pulsed during processor initialization.

TERMINAL CONNECTIONS

Case Outline		Z			
Terminal Number	Terminal Symbol	Terminal Number	Terminal Symbol	Terminal Number	Terminal Symbol
B1	IB ₁₄	LS	EDC ₁	D11	AS ₀
B2	IB ₁₃	KS	EDC ₀	D10	AS ₁
C1	IB ₁₂	L6	GND	C11	AS ₂
C2	IB ₁₁	K6	VCC	C10	AS ₃
D1	IB ₁₀	L7	<u>BUS REQ₁</u>	B11	VCC
D2	<u>BUS GNT₃</u>	K7	<u>BUS LOCK</u>	A10	GND
E1	IB ₉	L8	<u>BUS GNT₀</u>	B10	EXT ADR ₇
E2	IB ₈	K8	RDYA	A9	EXT ADR ₆
F1	<u>BUS REQ₃</u>	L9	M/IQ	B9	EXT ADR ₅
F2	IB ₇	K9	D/I	A8	EXT ADR ₄
G1	IB ₆	L10	<u>RAW</u>	B8	EXT ADR ₃
G2	IB ₅	K11	<u>WR PROT/PROT FLAG</u>	A7	EXT ADR ₂
H1	IB ₄	K10	EX RDY	B7	EXT ADR ₁
H2	IB ₃	J11	<u>BUS REQ₀</u>	A6	EXT ADR ₀
J1	IB ₂	J10	<u>STRBD</u>	B6	GND
J2	IB ₁	H11	STRBA	A5	DMA ACK
K1	IB ₀	H10	CLK	B5	SING ERR
L2	<u>BUS GNT₂</u>	G11	AK ₀	A4	RAM DIS
K2	EDC ₅	G10	AK ₁	B4	<u>EXT ADR ERR</u>
L3	EDC ₄	F11	<u>BUS GNT₁</u>	A3	<u>MEM PAR ERR</u>
K3	EDC ₃	F10	AK ₂	B3	<u>MEM PRT ERR</u>
L4	<u>RESET</u>	E11	AK ₃	A2	IB ₁₅
K4	EDC ₂	E10	<u>BUS REQ₂</u>		

TERMINAL CONNECTIONS

Case Outlines		U and Y			
Terminal Number	Terminal Symbol	Terminal Number	Terminal Symbol	Terminal Number	Terminal Symbol
1	GND	24	IB ₁₂	47	AS ₁
2	EDC ₀	25	IB ₁₃	48	AS ₀
3	EDC ₁	26	IB ₁₄	49	BUS REQ ₂
4	EDC ₂	27	IB ₁₅	50	AK ₃
5	RESET	28	MEM PRT ERR	51	AK ₂
6	EDC ₃	29	MEM PAR ERR	52	BUS GNT ₁
7	EDC ₄	30	EXT ADR ERR	53	AK ₁
8	EDC ₅	31	RAM DIS	54	AK ₀
9	BUS GNT ₂	32	SING ERR	55	CLK
10	IB ₀	33	DMA ACK	56	STRBA
11	IB ₁	34	GND	57	STRBD
12	IB ₂	35	V _{CC}	58	BUS REQ ₀
13	IB ₃	36	EXT ADR ₀	59	EX RDY
14	IB ₄	37	EXT ADR ₁	60	WR PROT/PROT FLAG
15	IB ₅	38	EXT ADR ₂	61	R/W
16	IB ₆	39	EXT ADR ₃	62	D/I
17	IB ₇	40	EXT ADR ₄	63	M/IQ
18	BUS REQ ₃	41	EXT ADR ₅	64	RDYA
19	IB ₈	42	EXT ADR ₆	65	BUS GNT ₀
20	IB ₉	43	EXT ADR ₇	66	BUS LOCK
21	BUS GNT ₃	44	GND	67	BUS REQ ₁
22	IB ₁₀	45	AS ₃	68	V _{CC}
23	IB ₁₁	46	AS ₂		

TERMINAL CONNECTIONS

Case Outlines		T and X			
Terminal Number	Terminal Symbol	Terminal Number	Terminal Symbol	Terminal Number	Terminal Symbol
1	GND	23	IB ₁₃	44	AS ₁
2	EDC ₀	24	IB ₁₄	45	AS ₀
3	EDC ₁	25	IB ₁₅	46	GND
4	EDC ₂	26	MEM PRT ERR	47	AK ₃
5	RESEI	27	MEM PAR ERR	48	AK ₂
6	EDC ₃	28	EXT ADR ERR	49	AK ₁
7	EDC ₄	29	RAM DIS	50	AK ₀
8	EDC ₅	30	SING ERR	51	CLK
9	IB ₀	31	DMA ACK	52	STRBA
10	IB ₁	32	GND	53	STRBD
11	IB ₂	33	EXT ADR ₀	54	GND
12	IB ₃	34	EXT ADR ₁	55	EX RDY
13	IB ₄	35	EXT ADR ₂	56	WB PROT/PROT FLAG
14	IB ₅	36	EXT ADR ₃	57	R/W
15	IB ₆	37	EXT ADR ₄	58	D/I
16	IB ₇	38	EXT ADR ₅	59	M/IO
17	IB ₈	39	EXT ADR ₆	60	RDYA
18	IB ₉	40	EXT ADR ₇	61	NC
19	VCC	41	VCC	62	NC
20	IB ₁₀	42	AS ₃	63	NC
21	IB ₁₁	43	AS ₂	64	VCC
22	IB ₁₂				

ORDERING INFORMATION

