



# SANYO Semiconductors DATA SHEET

## LA74308LP — Monolithic Linear IC Audio Interface for DSC

### Overview

The LA74308LP is a SPEAKER AMP and MIC AMP built-in audio interface for DSC. It incorporates an 8/16kHz trap and supports CODECs with a sampling rate of 8kHz or 16kHz.

### Features

- Three-wire type SERIAL communication
- MIC AMP
- MIC power supply incorporated (with built-in pull-up resistor)
- ALC AMP
- 4th order LPF + trap (compatible with REC/PB changeover, trap frequency selectable from 8kHz and 16kHz)
- SPEAKER AMP (The BEEP signal can be mixed.)
- Electronic VOLUME (controlled by serial communication)
- LINE output (with SERIAL MUTE and MUTE transistor)
- STANDBY control

### Specifications

Maximum Ratings at  $T_a=25^{\circ}\text{C}$

Parameter	Symbol	Conditions	Ratings	Unit
Maximum supply voltage	$V_{CC\ max}$		5.0	V
Allowable power dissipation	$P_d\ max$	$T_a \leq 85^{\circ}\text{C} *$	500	mW
Operating temperature	$T_{opr}$		-10 to +85	$^{\circ}\text{C}$
Storage temperature	$T_{stg}$		-55 to +150	$^{\circ}\text{C}$

\* Printed circuit board mounting condition (40mm × 50mm × 0.8mm: glass epoxy) 2S2P (Four layers printed circuit board)

■ Any and all SANYO Semiconductor Co.,Ltd. products described or contained herein are, with regard to "standard application", intended for the use as general electronics equipment (home appliances, AV equipment, communication device, office equipment, industrial equipment etc.). The products mentioned herein shall not be intended for use for any "special application" (medical equipment whose purpose is to sustain life, aerospace instrument, nuclear control device, burning appliances, transportation machine, traffic signal system, safety equipment etc.) that shall require extremely high level of reliability and can directly threaten human lives in case of failure or malfunction of the product or may cause harm to human bodies, nor shall they grant any guarantee thereof. If you should intend to use our products for applications outside the standard applications of our customer who is considering such use and/or outside the scope of our intended standard applications, please consult with us prior to the intended use. If there is no consultation or inquiry before the intended use, our customer shall be solely responsible for the use.

■ Specifications of any and all SANYO Semiconductor Co.,Ltd. products described or contained herein stipulate the performance, characteristics, and functions of the described products in the independent state, and are not guarantees of the performance, characteristics, and functions of the described products as mounted in the customer's products or equipment. To verify symptoms and states that cannot be evaluated in an independent device, the customer should always evaluate and test devices mounted in the customer's products or equipment.

**SANYO Semiconductor Co., Ltd.**

TOKYO OFFICE Tokyo Bldg., 1-10, 1 Chome, Ueno, Taito-ku, TOKYO, 110-8534 JAPAN

# LA74308LP

## Operating Conditions at Ta = 25°C

Parameter	Symbol	Conditions	Ratings	Unit
Recommended operating voltage	V <sub>CCA</sub>		3.0	V
	V <sub>CCSP</sub>		3.3	V
Allowable operating voltage range	V <sub>CCAop</sub>		2.7 to 3.6	V
	V <sub>CCSPop</sub>	Take care not to exceed Pd max.	2.7 to 3.6	V

## Electrical Characteristics at Ta=25°C, V<sub>CCA</sub>=3.0V, V<sub>CCSP</sub>=3.3V, f=1kHz, with the VREF capacitance charging circuit in the OFF MODE

Parameter	Symbol	Conditions	Ratings			Unit
			min	typ	max	
<b>Circuit current</b>						
V <sub>CCA</sub> current dissipation at no signal 1	I <sub>CCA1</sub>	V <sub>CCA</sub> =3.0V:REC BLOCK(MIC/ALC/REC AMP) POWER SAVE MODE	4.9	6.6	8.3	mA
V <sub>CCA</sub> current dissipation at no signal 2	I <sub>CCA2</sub>	V <sub>CCA</sub> =3.0V, LINE/SP AMP POWER SAVE MODE	6.2	8.3	10.4	mA
V <sub>CCA</sub> standby current dissipation 1	I <sub>CCAS1</sub>	V <sub>CCA</sub> =3.0V, during standby control V <sub>3</sub> =0V			1	μA
V <sub>CCA</sub> standby current dissipation 2	I <sub>CCAS2</sub>	V <sub>CCA</sub> =3.0V, BIAS MODE			800	μA
V <sub>CCSP</sub> current dissipation at no signal 1	I <sub>CCS1</sub>	V <sub>CCSP</sub> =3.3V, SPK POWER ON MODE	1	2	4	mA
V <sub>CCSP</sub> current dissipation at no signal 2	I <sub>CCS2</sub>	V <sub>CCSP</sub> =3.3V, SPK POWER SAVE MODE		0.05	0.1	mA
V <sub>CCSP</sub> standby current dissipation 1	I <sub>CCSS1</sub>	V <sub>CCSP</sub> =3.3V, during standby control (0V applied to pin 3)			9	μA
V <sub>CCSP</sub> standby current dissipation 2	I <sub>CCSS2</sub>	V <sub>CCSP</sub> =3.3V, BIAS MODE			9	μA
<b>REC output system</b>						
REC reference output LEVEL	VOR	ALC IN, V <sub>IN</sub> =-53dBV	-11	-9.5	-8	dBV
REC reference output distortion	HDR1	ALC IN, V <sub>IN</sub> =-53dBV, THD: from 2nd to 5th harmonic		0.1	0.2	%
ALC characteristics	ALM	ALC IN, V <sub>IN</sub> =-20dBV	-3	-1.8		dBV
ALC distortion	ALMD	ALC IN, V <sub>IN</sub> =-20dBV, THD: from 2nd to 5th harmonic		0.3	1	%
ALC IN max input level	VINRMX	ALC IN LEVEL at which REC output THD (from 2nd to 5th harmonic) becomes 3% or less.			-7	dBV
REC output noise voltage	VNOR	ALC IN, no input, JIS-A Filter		-70	-60	dBV
<b>LINE output system (LINE load = as measured at the 22kΩ end)</b>						
LINE reference output LEVEL	VOL	PB IN, V <sub>IN</sub> =-17dBV	-11	-9.5	-8	dBV
LINE reference output distortion	HDL	PB IN, V <sub>IN</sub> =-17dBV, THD: from 2nd to 5th harmonic		0.1	0.2	%
LINE reference output noise voltage	VNOL	PB IN, no input, JIS-A Filter		-77	-69	dBV
PB IN max input LEVEL	VINPMX	PB IN LEVEL at which LINE output THD (from 2nd to 5th harmonic) becomes 1% or less.			-9	dBV
LINE output frequency characteristics 1	FEQP1	PB IN, V <sub>IN</sub> =-10dBV, comparison of f=3kHz/1kHz	-3.5	-2		dB
LINE output frequency characteristics 2	FEQP2	PB IN, V <sub>IN</sub> =-10dBV, comparison of f=4kHz/1kHz		-10	-6	dB
LINE output frequency characteristics 3	FEQP3	PB IN, V <sub>IN</sub> =-10dBV, comparison of f=8kHz/1kHz		-55	-30	dB
<b>SP output system (SP load = as measured at the 8Ω end)</b>						
SP reference output LEVEL1 (Vol.MAX)	VOSP1	PB IN, V <sub>IN</sub> =-17dBV, Vol=MAX (EVR DATA=31)	-6	-3	0	dBV
SP reference output distortion	THDSP	PB IN, V <sub>IN</sub> =-17dBV, Vol=MAX, THD: from 2nd to 5th harmonic		0.4	1	%
SP reference output LEVEL2 (Vol.TYP)	VOSP2	PB IN, V <sub>IN</sub> =-17dBV, Vol=TYP (EVR DATA=14)	-18	-12	-6	dBV
SP reference output LEVEL3 (Vol.MIN)	VOSP3	PB IN, V <sub>IN</sub> =-17dBV, Vol=MIN (EVR DATA=0) JIS-A Filter		-80	-70	dBV
SP reference output noise voltage	VNOSP	PB IN no input, Vol=MAX, JIS-A Filter		-70	-64	dBV
SP maximum ratings output	VOMSP	PB IN, Vol=MAX, LEVEL at which THD=10%	200	320		mW

Continued on next page.

# LA74308LP

Continued from preceding page.

Parameter	Symbol	Conditions	Ratings			Unit
			min	typ	max	
<b>MIC output system</b>						
MIC voltage gain	VGMIC	MIC IN, $V_{IN}=-36\text{dBV}$	16	17	18	dB
MIC output distortion	HDMIC	MIC IN, $V_{IN}=-36\text{dBV}$ , THD: from 2nd to 5th harmonic		0.05	0.1	%
MIC output noise voltage	VNOMIC	MIC IN, no input, JIS-A Filter		-94	-83	dBV
MIC IN max input level	VINMMX	MIC IN LEVEL at which the MIC output THD (from 2nd to 5th harmonic) becomes 3% or less.			-25	dBV
MIC $V_{CC}$ output voltage	VMIC	At $6.2\text{k}\Omega$ load	1.5	1.7	1.9	V
<b>Control system</b>						
Serial CLOCK frequency	FCLK			0.1	1	MHz
Serial input LOW level	SERLO		0		0.7	V
Serial input HIGH level	SERHI		2.3		3.5	V

## Package Dimensions

unit : mm (typ)

3321

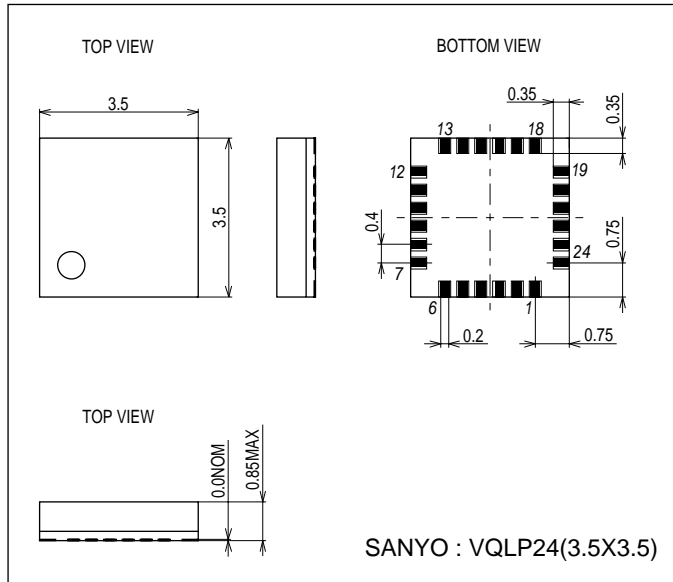

# LA74308LP

## Description of the Content of Serial Communication

	DATA No.	Parameter	Default	
LSB	0	LINE MUTE Tr. 0:OFF, 1:ON	1	
	1	VREF capacitance charging circuit SW 0:OFF, 1:ON	1	
	2	MIC AMP POWER SW 0:ON, 1:OFF	1	
	3	ALC AMP POWER SW 0:ON, 1:OFF	1	
	4	REC/PB changeover SW 0:PB, 1:REC	0	
	5	LPF characteristics (TRAP) changeover SW 0:16kHz, 1:8kHz	1	
	6	REC AMP POWER SW 0:ON, 1:OFF	1	
	7	LINE OUT POWER SW 0:ON, 1:OFF	1	
	8	LINE MUTE SW 0:OFF, 1:ON	1	
	9	SPK POWER SW 0:ON, 1:OFF	1	
	10	DATA=1 1 1 1 1 1:VOL MAX	* EVR setting (the numeral shown in the left is decimal. For characteristics, see P12.)	0
	11	DATA=2		0
	12	DATA=4 0 0 0 0 0:VOL MIN (MUTE)		0
	13	DATA=8		0
14	DATA=16	0		
MSB	15	BIAS MODE 0:ACTIVE MODE, 1:BIAS MODE	0	

## Serial Transmission Timing

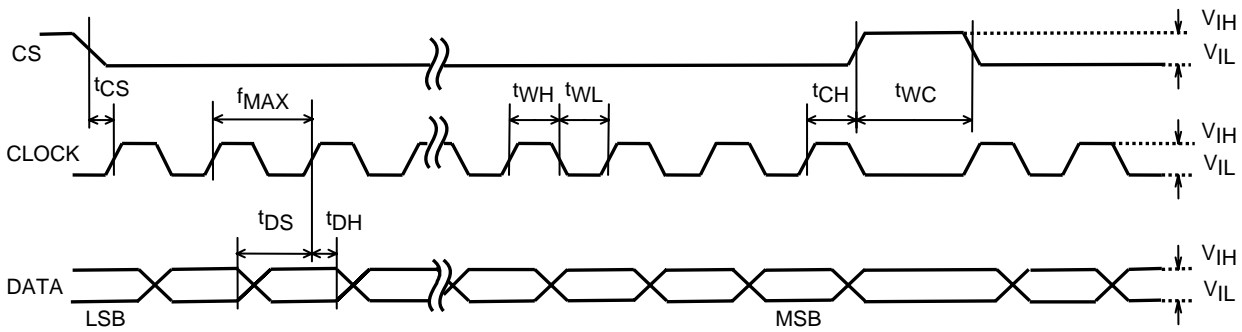

- $f_{MAX}$  (Max clock frequency) 1.0MHz
- $t_{WL}$  (Clock pulse width: Low) 500ns or more
- $t_{WH}$  (Clock pulse width: High) 500ns or more
- $t_{CS}$  (Chip enable setup time) 500ns or more
- $t_{CH}$  (Chip enable hold time) 500ns or more
- $t_{DS}$  (Data setup time) 500ns or more
- $t_{DH}$  (Data hold time) 500ns or more
- $t_{WC}$  (Chip enable pulse width) 500ns or more
- $V_{IH}$  (High voltage lower limit) 2.3V to 3.5V
- $V_{IL}$  (Low voltage upper limit) 0.0V to 0.7V

**POWER ON RESET Condition (SERIAL communication)**

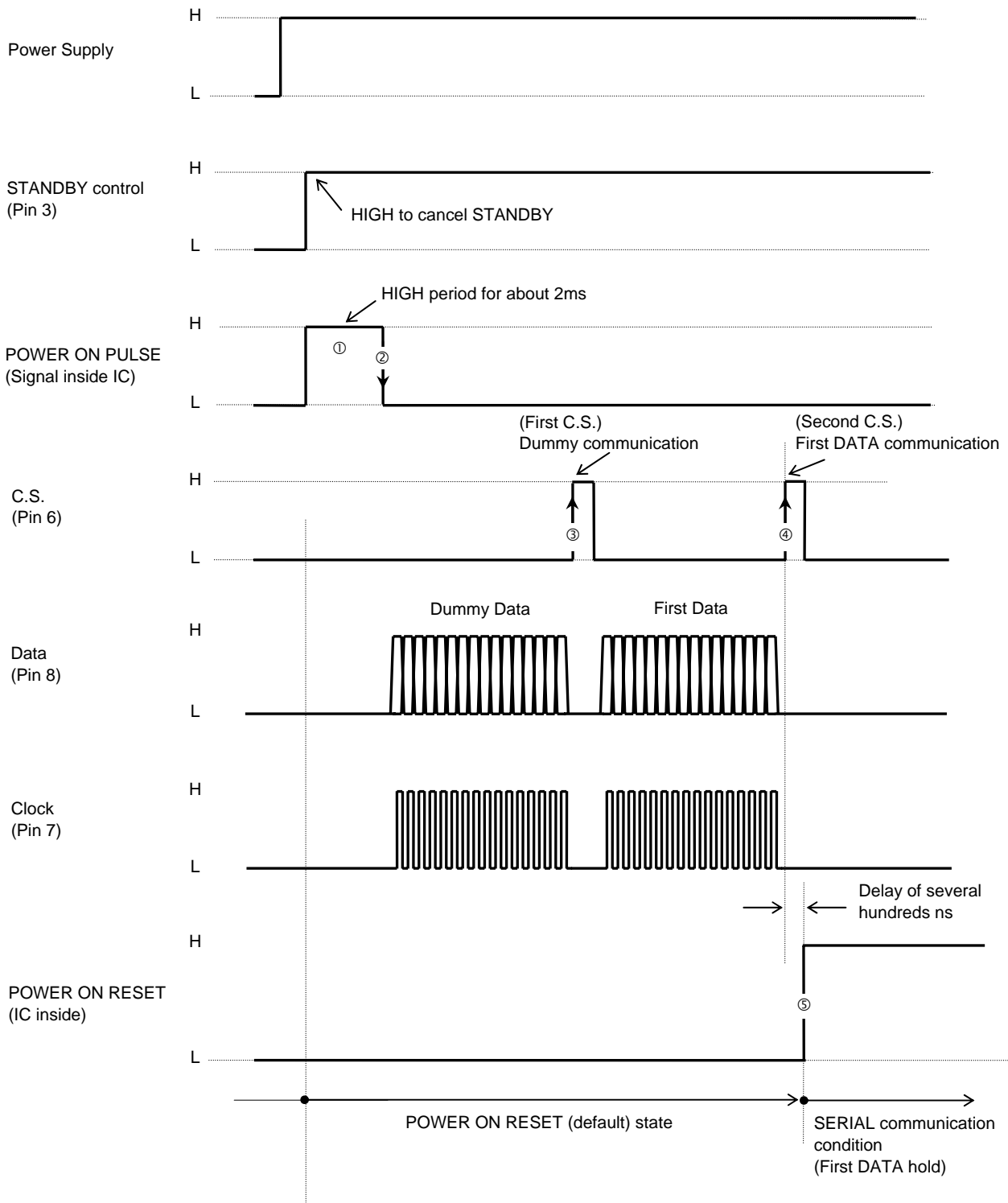

The POWER ON RESET state covers a period up to the rise ④ of the second C.S. input after fall ② of POWER ON PULSE ① generated inside IC when the power is supplied and the STANDBY control is canceled. ③ is the dummy communication.

Actually, because of delay of several hundreds ns in the IC, the first DATA condition begins in ⑤ and the normal SERIAL communication condition begins after ⑤.

**BIAS MODE Canceling State (SERIAL communication)**

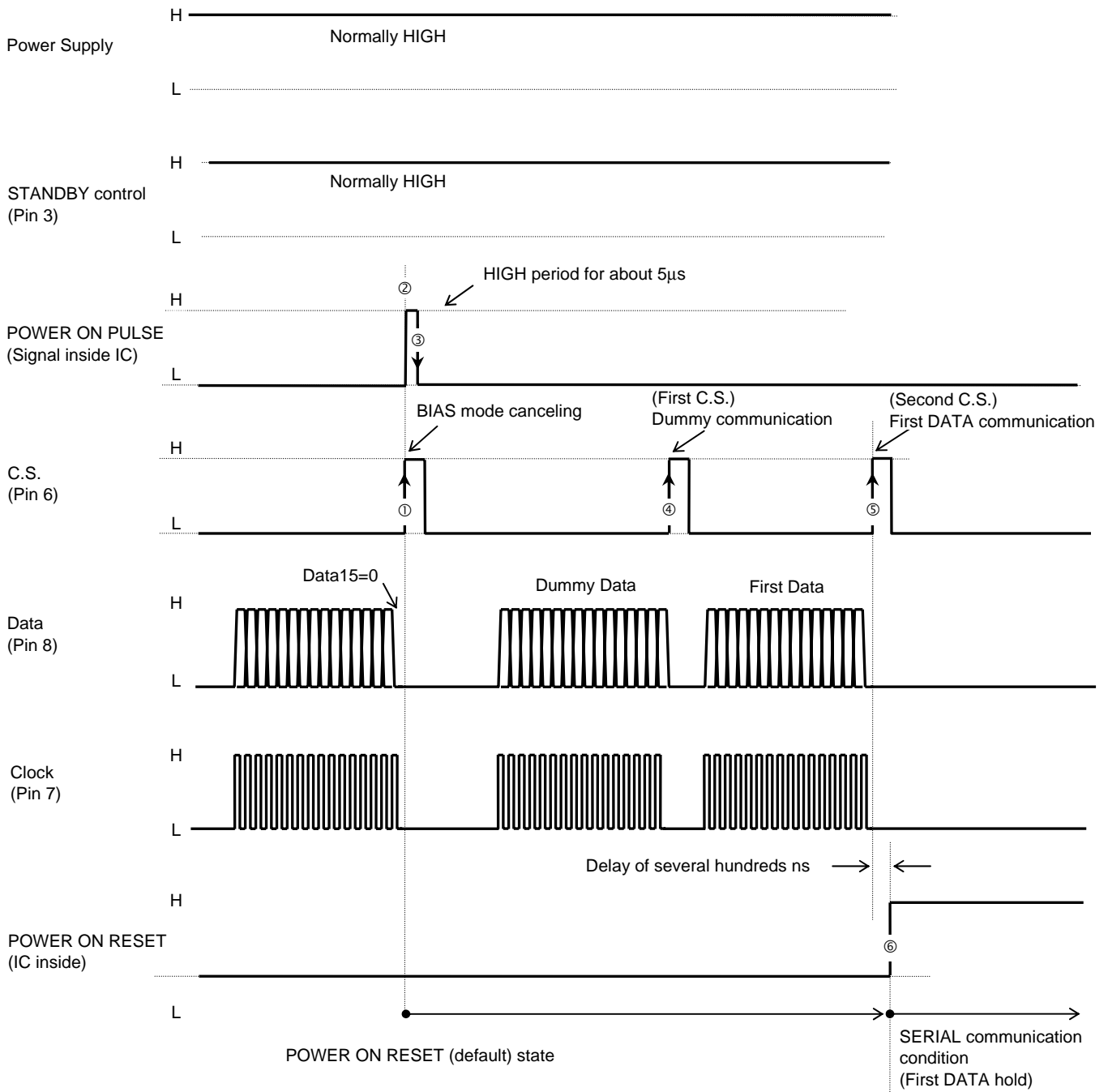

The POWER ON RESET state from the BIAS MODE covers the period from the rise of C.S ① for communication of canceling of the BIAS MODE to the second rise ⑤ of CS input after the fall ③ of POWER ON PULSE ② generated inside IC. ④ is the dummy communication. Actually, because of delay of several hundreds ns in the IC, the first DATA condition begins in ⑥ and the normal SERIAL communication condition begins after ⑥.

# LA74308LP

**Electrical Characteristics Measurement Method** at Ta=25°C, VCCA=3.0V, VCCSP=3.3V, f=1kHz with the VREF capacitance charging circuit in the OFF MODE

No.	Symbol	Pin	Input Conditions	Output	STANDBY pin	Serial control setting																				
						0	1	2	3	4	5	6	7	8	9	10	11	12	13	14	15					
<b>Circuit current</b>																										
1	ICCA1	T11	VCCA=3.0V No input	VREF capacitance charging circuit in the OFF MODE MIC/ALC/REC AMP POWER SAVE MODE	3.3V	0	0	1	1	0	1	1	0	1	0	1	0	0	0	0	0	0	0	0	0	
2	ICCA2	T11	VCCA=3.0V No input	VREF capacitance charging circuit in the OFF MODE LINE/SP AMP POWER SAVE MODE	3.3V	0	0	0	0	1	1	0	1	1	0	1	1	0	0	0	0	0	0	0	0	0
3	ICCA51	T11	VCCA=3.0V No input	With the STANDBY pin V3=0V	0V	0	0	0	0	0	1	0	0	1	0	0	0	0	0	0	0	0	0	0	0	0
4	ICCA52	T11	VCCA=3.0V No input	BIAS MODE	3.3V	0	0	0	0	0	0	0	0	1	0	1	0	0	0	0	0	0	0	0	0	1
5	ICCS1	T22	VCCSP=3.3V No input	VREF capacitance charging circuit in the OFF MODE SPK POWER ON MODE	3.3V	0	0	1	1	0	1	1	0	1	1	0	0	0	0	0	0	0	0	0	0	0
6	ICCS2	T22	VCCSP=3.3V No input	VREF capacitance charging circuit in the OFF MODE SPK POWER SAVE MODE	3.3V	0	0	1	1	0	1	1	0	1	1	0	0	1	1	0	0	0	0	0	0	0
7	ICCSS1	T22	VCCSP=3.3V No input	With the STANDBY pin V3=0V	0V	0	0	1	1	0	1	1	0	1	1	0	0	0	0	0	0	0	0	0	0	0
8	ICCSS2	T22	VCCSP=3.3V No input	BIAS MODE	3.3V	0	0	1	1	0	1	1	0	1	1	0	0	1	1	0	0	0	0	0	0	1
<b>REC output system</b>																										
9	VOR	T14	VIN=53dBV f=1kHz	400 to 20kHz LPF used SW14=A, SW16=B	3.3V	0	0	0	0	1	1	0	1	1	0	1	1	1	1	0	0	0	0	0	0	0
10	HDR1	T14	VIN=53dBV f=1kHz	400 to 20kHz LPF used, SW14=A SW16=B, THD: from 2nd to 5th harmonic	3.3V	0	0	0	0	1	1	0	1	1	0	1	1	1	1	0	0	0	0	0	0	0
11	ALM	T14	VIN=20dBV f=1kHz	400 to 20kHz LPF used, SW14=A, SW16=B	3.3V	0	0	0	0	1	1	0	1	1	0	1	1	1	1	0	0	0	0	0	0	0
12	ALMD	T14	VIN=20dBV f=1kHz	400 to 20kHz LPF used, SW14=A SW16=B, THD: from 2nd to 5th harmonic	3.3V	0	0	0	0	1	1	0	1	1	0	1	1	1	1	0	0	0	0	0	0	0
13	VINRMX	T14	f=1kHz	400 to 20kHz LPF used, SW16=B Pin 14 level at which pin 12 becomes THD = 3% from 2nd to 5th harmonic	3.3V	0	0	0	0	1	1	0	1	1	0	1	1	1	1	0	0	0	0	0	0	0
14	VNOR	T14	No input	JIS-A FILTER used SW14=B, SW16=B	3.3V	0	0	0	0	1	1	0	1	1	0	1	1	1	1	0	0	0	0	0	0	0

No.	Symbol	Input		Output	STANDBY pin	Serial control setting																					
		Pin	Conditions			Pin	Major conditions (for the serial control setting, see the table in the right)	Voltage applied to pin 3	0	1	2	3	4	5	6	7	8	9	10	11	12	13	14	15			
<b>LINE output system</b>																											
15	VOL1	T10	$V_{IN}=-17\text{dBV}$ $f=1\text{kHz}$	T5	400 to 20kHz LPF used SW10=A, SW16=A	3.3V	0	1	1	1	0	1	1	0	0	1	0	0	0	0	0	0	0	0	0	0	
16	HDL	T10	$V_{IN}=-17\text{dBV}$ $f=1\text{kHz}$	T5	400 to 20kHz LPF used, SW10=A SW16=A, THD: from 2nd to 5th harmonic	3.3V	0	1	1	1	0	1	1	0	1	1	0	1	0	0	0	0	0	0	0	0	0
17	VNOL	T10	No input	T5	JIS-A FILTER used, SW10=B, SW16=A	3.3V	0	1	1	1	0	1	1	0	1	0	1	0	0	0	0	0	0	0	0	0	0
18	VINPMX	T10	$f=1\text{kHz}$	T5	400 to 20kHz LPF used, SW10=A, Pin 10 level at which pin 5 becomes THD = 3% (from 2nd to 5th harmonic)	3.3V	0	1	1	1	0	1	1	0	1	0	1	0	0	0	0	0	0	0	0	0	0
19	FEQP1	T10	$V_{IN}=-10\text{dBV}$ $f=3\text{kHz}$	T5	$f=3\text{kHz}/1\text{kHz}$ level ratio SW10=A, SW16=A	3.3V	0	1	1	1	0	1	1	0	1	0	1	0	0	0	0	0	0	0	0	0	0
20	FEQP2	T10	$V_{IN}=-10\text{dBV}$ $f=4\text{kHz}$	T5	$f=4\text{kHz}/1\text{kHz}$ level ratio SW10=A, SW16=A	3.3V	0	1	1	1	0	1	1	0	1	0	1	0	0	0	0	0	0	0	0	0	0
21	FEQP3	T10	$V_{IN}=-10\text{dBV}$ $f=8\text{kHz}$	T5	$f=8\text{kHz}/1\text{kHz}$ level ratio SW10=A, SW16=A	3.3V	0	1	1	1	0	1	1	0	1	0	1	0	0	0	0	0	0	0	0	0	0
<b>SPK output system (SPK end: measured with 8Ω)</b>																											
22	VOSP1	T10	$V_{IN}=-17\text{dBV}$ $f=1\text{kHz}$	T21 T23	400 to 20kHz LPF used Vol.=MAX (EVR DATA=31)	3.3V	0	1	1	1	0	1	1	0	1	1	0	1	1	1	1	1	1	1	1	1	0
23	THDSP	T10	$V_{IN}=-17\text{dBV}$ $f=1\text{kHz}$	T21 T23	400 to 20kHz LPF used, Vol.=MAX THD: from 2nd to 5th harmonic	3.3V	0	1	1	1	0	1	1	0	1	1	0	1	1	1	1	1	1	1	1	1	0
24	VOSP2	T10	$V_{IN}=-17\text{dBV}$ $f=1\text{kHz}$	T21 T23	400 to 20kHz LPF used Vol.=TYP (EVR DATA=14)	3.3V	0	1	1	1	0	1	1	0	1	1	0	1	1	1	1	1	1	1	1	1	0
25	VOSP3	T10	$V_{IN}=-17\text{dBV}$ $f=1\text{kHz}$	T21 T23	JIS-A FILTER used Vol.=MIN (EVR DATA=0)	3.3V	0	1	1	1	0	1	1	0	1	1	0	1	1	1	1	1	1	1	1	1	0
26	VNOSP	T10	No input	T21 T23	JIS-A FILTER used Vol.=MAX (EVR DATA=31)	3.3V	0	1	1	1	0	1	1	0	1	1	0	1	1	1	1	1	1	1	1	1	0
27	VOSSP	T10	$f=1\text{kHz}$	T21 T23	400 to 20kHz LPF used Vol.=MAX (EVR DATA=31) Level at which Vol.=MAX and THD=10% (from 2nd to 5th harmonic)	3.3V	0	1	1	1	0	1	1	0	1	1	0	1	1	1	1	1	1	1	1	1	0



No.	Symbol	Input		Output	STANDBY pin	Serial control setting																															
		Pin	Conditions			Pin	Major conditions (for the serial control setting, see the table in the right)	0	1	2	3	4	5	6	7	8	9	10	11	12	13	14	15														
						LINE Mute Tr.	0:OFF 1:ON	VREF charging SW	0:OFF 1:ON	MIC P SW	0:ON 1:OFF	ALC P SW	0:ON 1:OFF	REC /PB SW	0:PB 1:REC	LPF TRAP	0:16kHz 1:8kHz	REC P SW	0:ON 1:OFF	LINE P SW	0:ON 1:OFF	LINE Mute	0:OFF 1:ON	SPK P SW	0:ON 1:OFF	EVR1 DATA	0:OFF 1:ON	EVR2 DATA	0:OFF 1:ON	EVR4 DATA	0:OFF 1:ON	EVR8 DATA	0:OFF 1:ON	EVR16 DATA	0:OFF 1:ON	BIAS MODE	0:ACTIVE 1:BIAS
<b>MIC Output system</b>																																					
28	VGMIC	T17	$V_{IN}=36dBV$ $f=1kHz$	T16	400 to 20kHz LPF used, SW17=A	0	0	0	0	0	0	0	0	1	1	0	0	0	1	1	1	1	1	0	0	0	0	0	0	0	0	0	0	0	0	0	
29	HDMIC	T17	$V_{IN}=36dBV$ $f=1kHz$	T16	400 to 20kHz LPF used, SW17=A THD: from 2nd to 5th harmonic	0	0	0	0	0	0	0	0	1	1	0	0	0	1	1	1	1	1	0	0	0	0	0	0	0	0	0	0	0	0	0	
30	VNOMIC	T17	No input	T16	JIS-A FILTER used, SW17=B	0	0	0	0	0	0	0	0	1	1	0	0	0	1	1	1	1	0	0	0	0	0	0	0	0	0	0	0	0	0	0	
31	VINMMX	T17	$f=1kHz$	T16	400 to 20kHz LPF used, SW17=A Pin 17 level at which pin 16 becomes THD = 3% (from 2nd to 5th harmonic)	0	0	0	0	0	0	0	0	1	1	0	0	0	1	1	1	1	1	0	0	0	0	0	0	0	0	0	0	0	0	0	0
32	VMIC	T17	No input	T18	Pin 18 Measurement of output voltage (under 6.2k $\Omega$ load) SW18=ON	0	0	0	0	0	0	0	0	1	1	0	0	0	1	1	1	1	0	0	0	0	0	0	0	0	0	0	0	0	0	0	

# LA74308LP

## Description of Pin Functions

Pin No.	Pin Description
1	Speaker input
2	EVR output
3	STANDBY control
4	LINE output
5	LINE MUTE Tr. output
6	C.S. input
7	CLOCK input
8	DATA input
9	GND
10	PB input
11	VCCA
12	REC output
13	ALC detection
14	ALC input
15	2nd order HPF
16	MIC output
17	MIC input
18	INT power supply for MIC
19	Ripple rejection for VREFL
20	SPK GND
21	Speaker positive-phase output
22	VCCSP
23	Speaker negative-phase output
24	SPK GND

Block Diagram

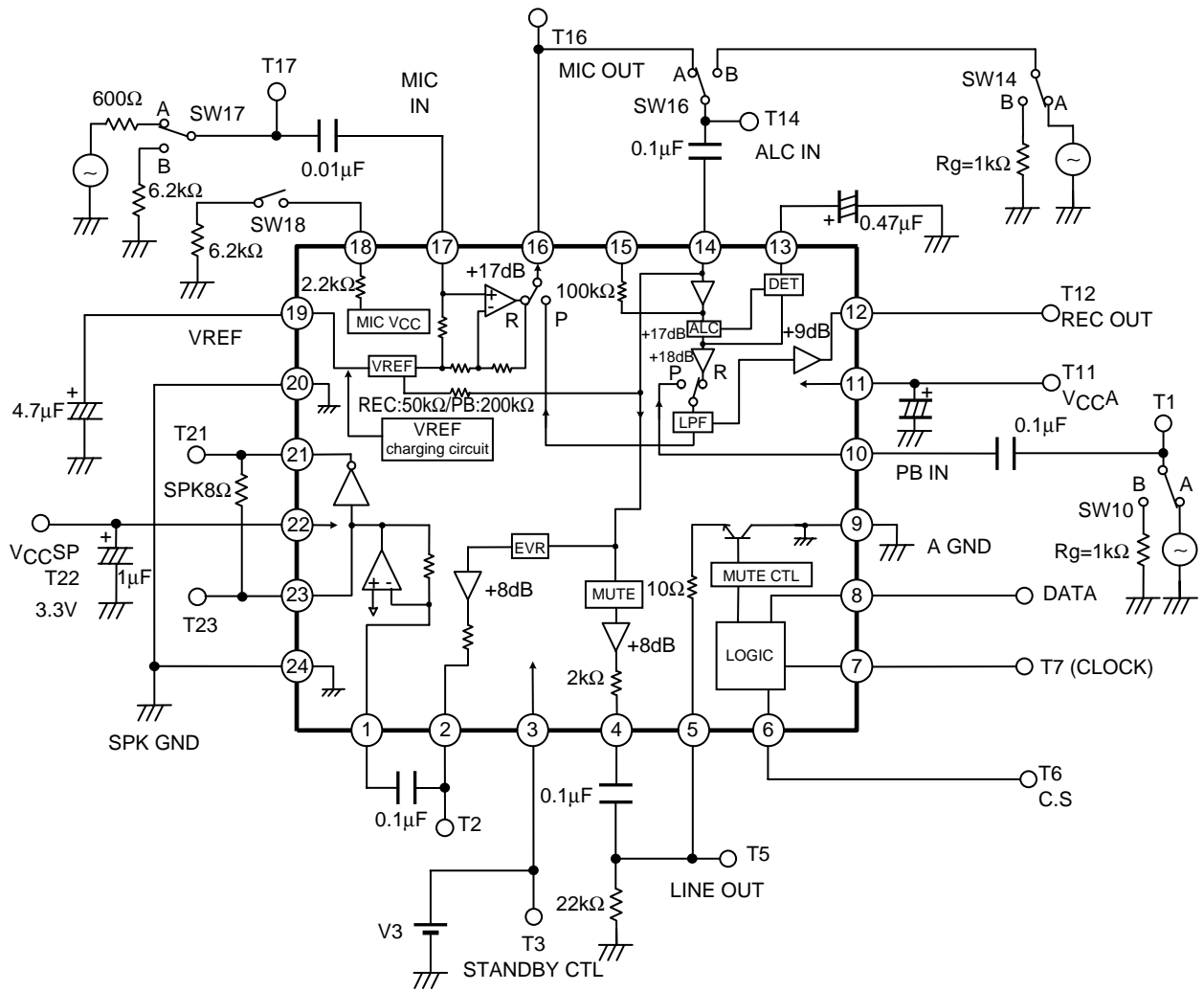

# LA74308LP

## LPF Characteristics

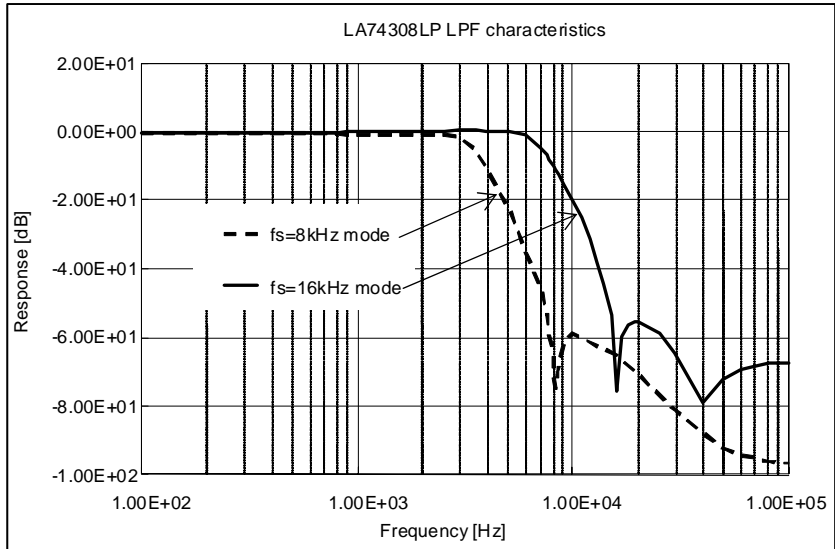

## EVR Characteristics

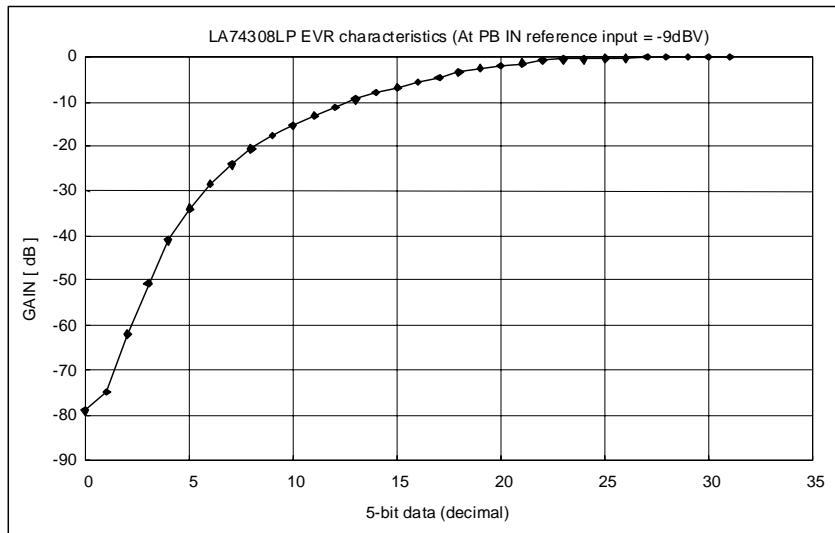

## SPK Output Level & Distortion Rate

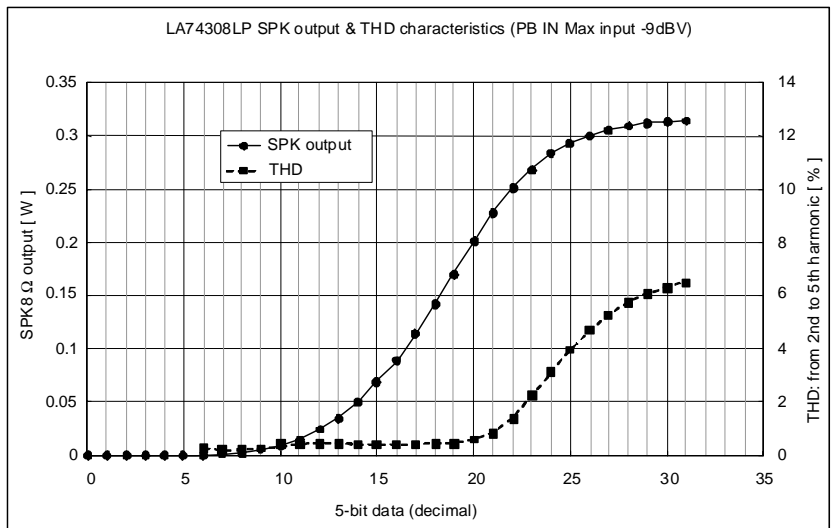

# LA74308LP

## LA74308LP Input/output Pattern Table

PIN	Pin Name	DC voltage	AC voltage	Description of functions	Equivalent circuit diagram in pin
1	SP IN	1.27V	At PB reference input Output level = -9dBV (EVR MAX)	Speaker input pin	
23	SPK OUT-	1.27V	At PB reference input Output level = -9dBV (EVR MAX)	Speaker negative-phase output pin	
2	EVR OUT	1.5V		EVR output pin	
3	STANDBY L			STANDBY control pin 2V or more: STANDBY canceled	
4	LINE OUT			LINE output pin	
5	LINE MUTE	1.5V	At PB reference input Output level = -9dBV	LINE output mute transistor	
6	CS			CS input pin	
7	CLOCK			CLOCK input pin	
8	DATA			DATA input pin	

Continued on next page.

# LA74308LP

Continued from preceding page.

PIN	Pin Name	DC voltage	AC voltage	Description of functions	Equivalent circuit diagram in pin
9	GND	0V		GND pin	
10	PB IN	1.5V	Reference input level =-17dBV	PB input pin	
11	V <sub>CC</sub>	3V		Power supply pin	
12	REC OUT	1.5V	Reference input level =-9dBV	R output pin	
13	ALC DET			ALC detection pin	
14	ALC IN (REC)	1.5V	Reference input level =-53dBV  Max input level =-8dBV	ALC input pin	
	EVR IN (PB)	1.5V		EVR input pin	
15	HPF	1.5V		Used when forming the 2nd order HPF	

Continued on next page.

# LA74308LP

Continued from preceding page.

PIN	Pin Name	DC voltage	AC voltage	Description of functions	Equivalent circuit diagram in pin
16	MIC OUT (REC)	1.5V		MIC output pin (for REC mode)	
	LPF OUT (PB)			LPF output pin (for PB mode)	
17	MIC IN	1.5V	Reference input level =-70dBV  Max input level =-25dBV	MIC input pin	
18	MIC V <sub>CC</sub>	2.30V		MIC power pin	
19	VREFL	2.30V		MIC V <sub>CC</sub> and VREFL ripple rejection pin	
20 24	SP GND	0V		Speaker GND pin	
21	SPK OUT+	1.27V	At PB reference input Output level = -9dBV (EVR MAX)	Speaker positive-phase output pin	
22	V <sub>CCSP</sub>	3.3V		Speaker power pin	

