

# PC BOARD CONNECTORS

## 700 SERIES

### ■ FEATURES

The 700 series connector has a superior ejector with a unique flexible latch. Terminals are palladium plated and have an excellent cost performance ratio. The solder dip section is a 0.5 mm (0.020 in.) square and can be used in a  $\phi$ 0.8 mm (0.031 in.) through hole. Special strain relief prevents breakage. Two kinds of keys and bump polarization prevent incorrect insertion. Connectors with 4 mm (0.157 in.) long tails are also available for mounting on multilayer PC boards.

### ■ SPECIFICATIONS

Item	Specification
Operating temperature range	-55°C to +105°C
Current rating	DC 1 A
Voltage rating	AC 250 V
Contact resistance	120 m $\Omega$ max. (DC 6 V, 0.1 A)
Insulation resistance	1000 M $\Omega$ min. (DC 500 V)
Dielectric strength	AC 500 V for 1 minute
Insertion force	3.5 kg max. (10 pins), 21 kg max. (60 pins)
Withdrawal force	0.25 kg min. (10 pins), 2.5 kg min. (60 pins)
Applicable wire	Flat cable: 1.27 mm (0.050 in.) pitch AWG #28 (stranded wires) or AWG #30 (solid wire)
Applicable wire-wrapping wire	AWG #26 to #30 (solid wire)
Applicable PC board (standard)	1.6 mm (0.062 in.) for standard terminal, 3.2 mm (0.125 in.) for long tail

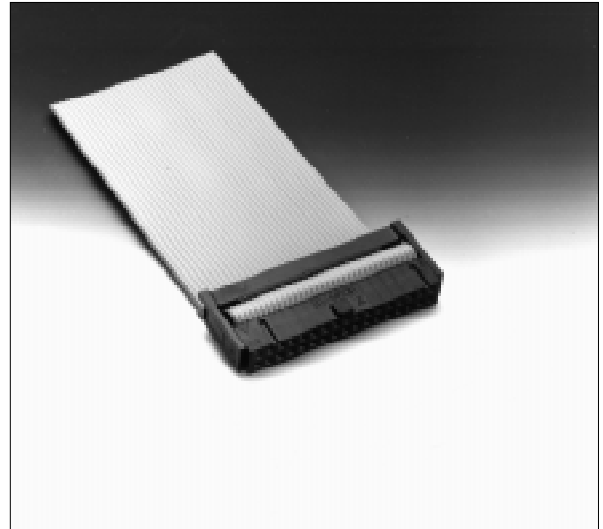

### ■ MATERIALS

Item	Materials	
Insulating material	Polyester (UL94V-0)	
Conductor	Copper alloy	
Plating	Contact	Gold
	Terminal	Palladium

## IDC HEADER M6 SERIES

### ■ DIMENSIONS

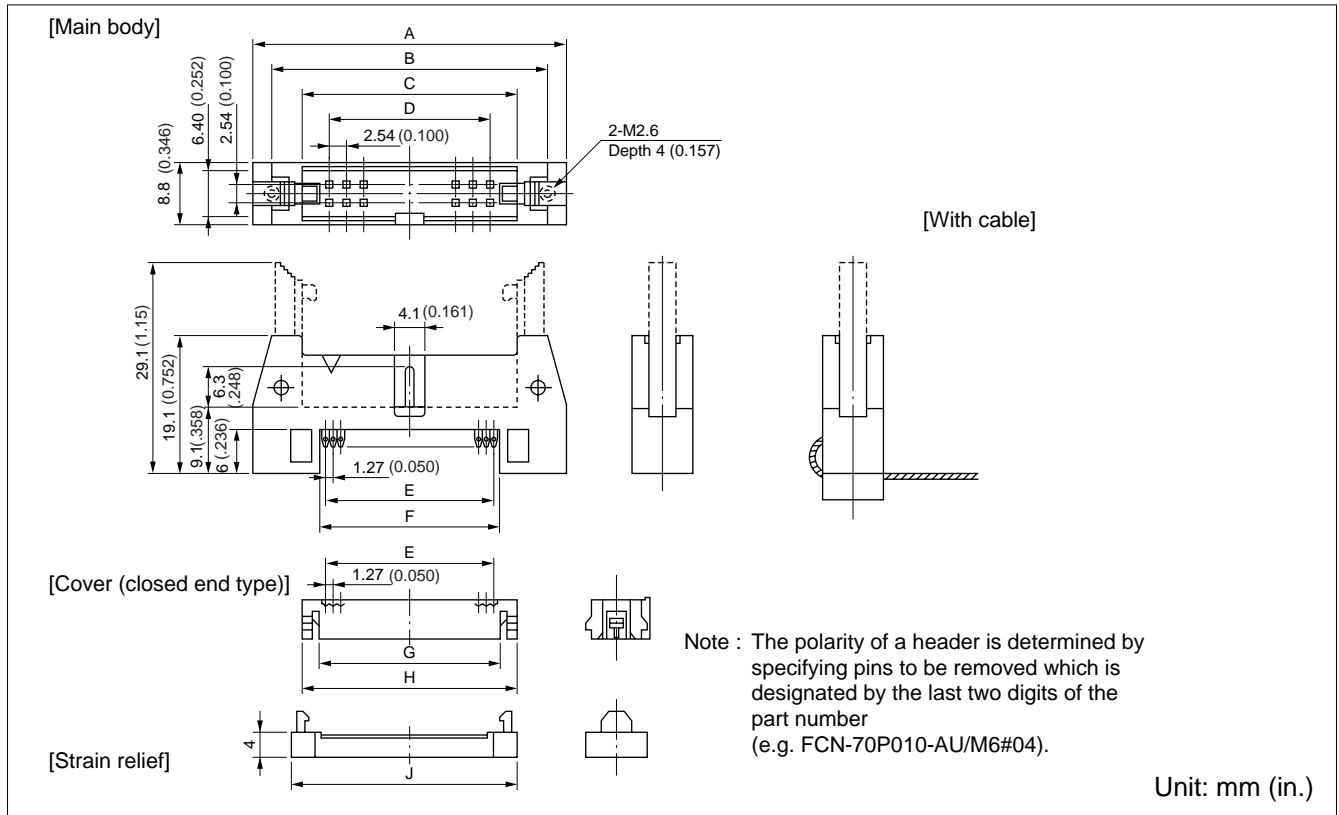

### ■ PART NUMBERS AND DIMENSIONS

Number of contacts	Without mini latch	With mini latch	Dimensions: mm (in.)								
			A	B	C	D	E	F	G	H	J
10	FCN-707P010-AU/0	FCN-707P010-AU/M6	32.0 (1.25)	26.80 (1.06)	18.3 (.720)	10.16 (.400)	11.43 (.450)	13.43 (.528)	13.43 (.528)	18.3 (.720)	20.2 (.795)
14	FCN-707P014-AU/0	FCN-707P014-AU/M6	37.1 (1.46)	31.90 (1.26)	23.4 (.921)	15.24 (.600)	16.51 (.650)	18.53 (.729)	18.53 (.729)	23.4 (.921)	25.3 (.996)
16	FCN-707P016-AU/0	FCN-707P016-AU/M6	39.62 (1.56)	34.42 (1.36)	25.9 (1.02)	17.78 (.700)	19.05 (.750)	21.03 (.828)	21.03 (.828)	25.9 (1.02)	27.8 (1.09)
20	FCN-707P020-AU/0	FCN-707P020-AU/M6	44.7 (1.76)	39.50 (1.56)	31.0 (1.22)	22.86 (.900)	24.13 (.950)	26.13 (1.03)	26.13 (1.03)	31.0 (1.22)	32.9 (1.29)
26	FCN-707P026-AU/0	FCN-707P026-AU/M6	52.32 (2.06)	47.12 (1.86)	38.6 (1.52)	30.48 (1.20)	31.75 (1.25)	33.73 (1.33)	33.73 (1.33)	38.6 (1.52)	40.5 (1.59)
30	FCN-707P030-AU/0	FCN-707P030-AU/M6	57.4 (2.26)	52.20 (2.06)	43.7 (1.72)	35.56 (1.40)	36.83 (1.45)	38.83 (1.53)	38.83 (1.53)	43.7 (1.72)	45.6 (1.79)
34	FCN-707P034-AU/0	FCN-707P034-AU/M6	62.48 (2.46)	57.28 (2.26)	48.8 (1.92)	40.64 (1.60)	41.91 (1.65)	43.93 (1.73)	43.93 (1.73)	48.8 (1.92)	50.7 (2.00)
40	FCN-707P040-AU/0	FCN-707P040-AU/M6	70.1 (2.76)	64.90 (2.56)	56.4 (2.22)	48.26 (1.90)	49.53 (1.95)	51.53 (2.03)	51.53 (2.03)	56.4 (2.22)	58.3 (2.29)
50	FCN-707P050-AU/0	FCN-707P050-AU/M6	82.8 (3.26)	77.60 (3.06)	69.1 (2.72)	60.96 (2.40)	62.23 (2.45)	64.23 (2.53)	64.23 (2.53)	69.1 (2.72)	71.0 (2.79)
60	FCN-707P060-AU/0	FCN-707P060-AU/M6	95.5 (3.76)	90.30 (3.56)	81.8 (3.22)	73.66 (2.90)	74.93 (2.95)	76.93 (3.03)	76.93 (3.03)	81.8 (3.22)	83.7 (3.29)

Note: For 'Lite PAGOS' add -HN to part number.

## IDC TOOLS

### ■ FEATURES

- Special IDC tools are used to assemble FCN-700 series connectors and flat cables.
- All tools are simple and easy to use, even for first-time users.
- Users who have IDC tools manufactured by us do not have to buy hand presses or cutting cables. They are compatible. Please buy the locator plate designed for your connectors.
- The number of pins can be changed easily by setting the connector guide to a specified pin hole.
- The cable cutter remains sharp, giving fast, easy cutting with a long life.

Notes: • Please ask for an operation instruction manual if needed.

- If you have any questions about Fujitsu IDC tools, please contact your local Fujitsu office or your local Fujitsu distributor.

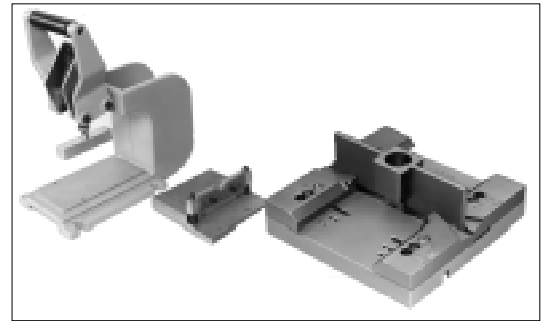

Hand press    Cable cutter    Locator plate

### ■ CABLE TERMINATION

#### • Flat cable termination diagram

There are many ways to connect connectors to flat cables. Choose the best connection method for your application from the figure below.

The orientation of a connector is important when you specify polarity to prevent incorrect insertion of 700 series clip types.

Discrete wire insulation displacement connection is possible, but cable assembly is not simple. Please contact us for details.

#### • Cable length

The length of a cable is indicated in units of cm, as shown in the figure below. The minimum length is 3 cm. The specified tolerance of the cable length is  $\pm 10\%$  for  $L \leq 10$  cm ( $\pm 5$  mm min.),  $\pm 1$  cm for  $10$  cm  $< L < 100$  cm,  $\pm(L/100$  cm  $+ 2$  cm) for  $100$  cm  $\leq L \leq 1800$  cm, and  $\pm 20$  cm for  $1800$  cm  $< L$ .

Type number	No. 1	No. 2	No. 3	No. 4
700 series				
707P series				

### ■ PART NUMBERS FOR IDC TOOLS

Name	Part number
Cable cutter (common)	FCN-707T-T001/H
Hand press (common)	FCN-707T-T101/H
Locator plate 700 series socket	FCN-707T-T022/H
Locator plate 700 series plug (for 707P series)	FCN-707T-T025/H
Locator plate 700 series plug (for 707P series M6 type)	FCN-707T-T036/H

The hand press and the cable cutter can be used for other IDC connectors.

## **Fujitsu Components International Headquarter Offices**

### **Japan**

Fujitsu Component Limited  
Gotanda-Chuo Building  
3-5, Higashigotanda 2-chome, Shinagawa-ku  
Tokyo 141, Japan  
Tel: (81-3) 5449-7010  
Fax: (81-3) 5449-2626  
Email: [promothq@ft.ed.fujitsu.com](mailto:promothq@ft.ed.fujitsu.com)  
Web: [www.fcl.fujitsu.com](http://www.fcl.fujitsu.com)

### **North and South America**

Fujitsu Components America, Inc.  
250 E. Caribbean Drive  
Sunnyvale, CA 94089 U.S.A.  
Tel: (1-408) 745-4900  
Fax: (1-408) 745-4970  
Email: [marcom@fcai.fujitsu.com](mailto:marcom@fcai.fujitsu.com)  
Web: [www.fcai.fujitsu.com](http://www.fcai.fujitsu.com)

### **Europe**

Fujitsu Components Europe B.V.  
Diamantlaan 25  
2132 WV Hoofddorp  
Netherlands  
Tel: (31-23) 5560910  
Fax: (31-23) 5560950  
Email: [info.marketing@fceu.fujitsu.com](mailto:info.marketing@fceu.fujitsu.com)  
Web: [www.fceu.fujitsu.com](http://www.fceu.fujitsu.com)

### **Asia Pacific**

Fujitsu Components Asia Ltd.  
102E Pasir Panjang Road  
#04-01 Citilink Warehouse Complex  
Singapore 118529  
Tel: (65) 375-8560  
Fax: (65) 273-3021  
Email: [fcal@fcal.fujitsu.com](mailto:fcal@fcal.fujitsu.com)  
[www.fcal.fujitsu.com](http://www.fcal.fujitsu.com)

© 2001 Fujitsu Components America, Inc. All company and product names are trademarks or registered trademarks of their respective owners. Rev. 09/2001