

XL CONNECTOR

Disconnectable Crimp style connectors

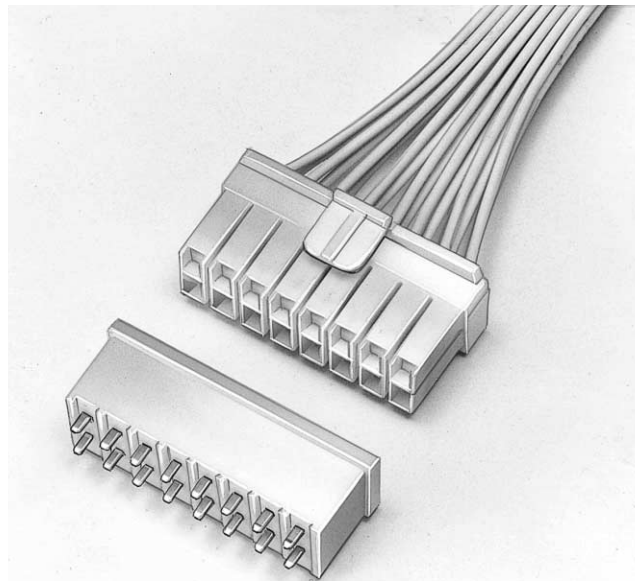

The reliable XL connectors have been developed by utilizing the technology of JST's field proven VH and SM connectors. The XL connectors are being used in electric appliances, vending machines, and office automation equipment.

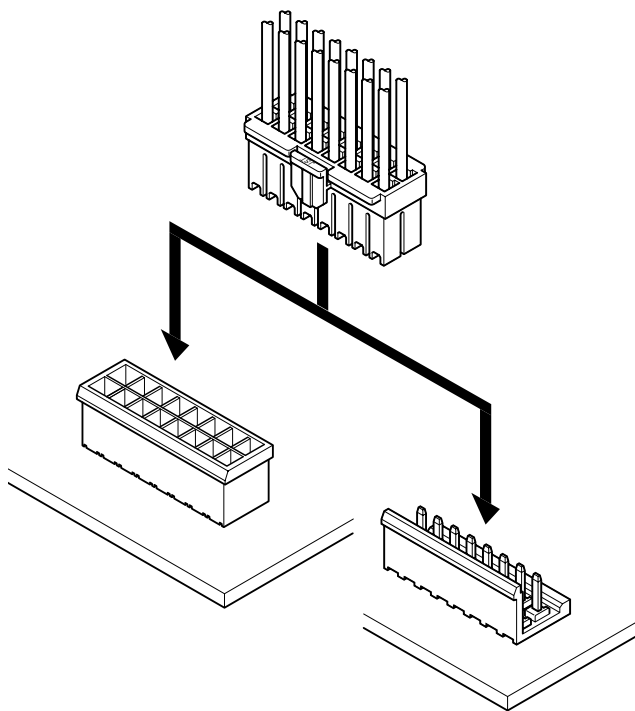

Features

• Reliable housing construction

Since all contacts are individually and totally surrounded by housing walls, and since the connector pitch is 5.0mm (.197"), the creep and space distances between the contacts are large enough to meet stringent safety requirements.

• Easy contact insertion

The contacts can be inserted into the housing easily and smoothly.

• Box-shaped contact

The box-shaped contact used successfully in the VH and NH connectors is also used in the XL connectors. This contact is adaptable to a wide range of applications, from low-voltage, low-current signal circuits to power supply circuits.

• Two kinds of connections

The XL connectors can be used for wire-to-wire connection and for printed circuit board connection.

Specifications

- Current rating: 10A AC, DC (Refer to the table below.)
- Voltage rating: 150V AC, DC
- Temperature range: -25°C to +90°C
(including temperature rise in applying electrical current)
- Contact resistance: Initial value/7m Ω max.
After environmental testing/10m Ω max.
- Insulation resistance: 1,000M Ω min.
- Withstanding voltage: 1,500V AC/minute
- Applicable wire: AWG #26 to #16
- Applicable PC board thickness: 1.6mm(.063")
- * Contact JST if Lead-Free product is required.
- * Refer to "General Instruction and Notice when using Terminals and Connectors" at the end of this catalog.
- * Contact JST for details.

Note:

The rated current varies depending on the number of circuits and the size of the wire to be connected by crimping.

Current unit:A

Circuits	Wire size(AWG)					
	#16	#18	#20	#22	#24	#26
2	10	6	5	4	3	3
3	9	5	4	3	3	2
4	9	5	4	3	3	2
8	6	4	3	3	2	2
12	6	4	3	3	2	2
16	5	3	2	2	1	1

Note:

Do not branch in parallel current which exceeds the rated current per circuit listed below. (Example: more than 10A in the case of a 2-circuit connector using AWG #16 wires.) If branched in parallel, current imbalance or other problems may develop.

Standards

Ⓜ Recognized E60389

Ⓢ Certified LR20812

Ⓡ R75150

Contact

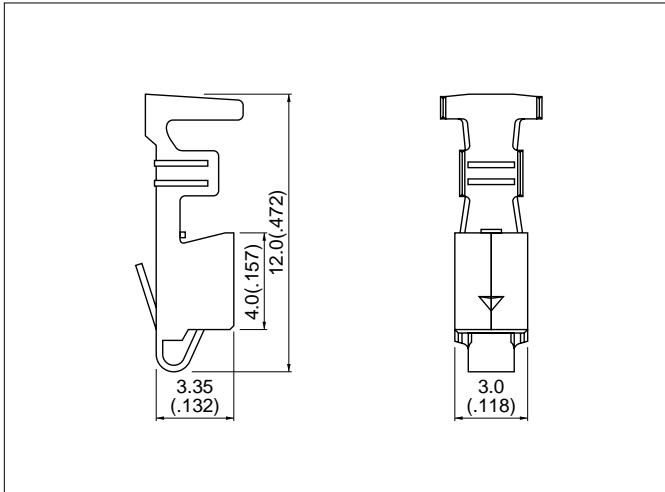

Model No.	Applicable wire			Q'ty / reel
	mm ²	AWG #	Insulation O.D. mm(in.)	
SXF-01T-P0.7	0.13 to 0.5	26 to 20	1.3 to 2.7(.051 to .106)	3,000
SXF-41T-P0.7	0.5 to 1.25	20 to 16	1.9 to 3.1(.075 to .122)	
	0.3X2 to 0.5X2	22X2 to 20X2	1.7X2 to 2.0X2(.067X2 to .079X2)	

Material and Finish

Phosphor bronze, tin-plated

Housing

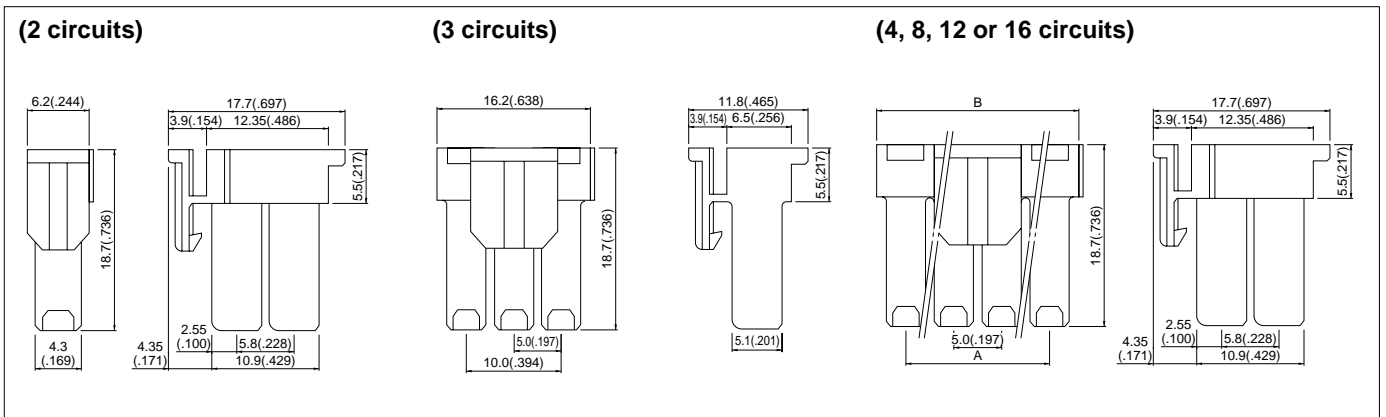

Circuits	Model No.	Dimensions mm(in.)		Q'ty / bag
		A	B	
2	XLP-02V	—	—	500
3	XLP-03V	—	—	500
4	XLP-04V	5.0(.197)	11.2(.441)	500
8	XLP-08V	15.0(.591)	21.2(.835)	500
12	XLP-12V	25.0(.984)	31.2(1.228)	200
16	XLP-16V	35.0(1.378)	41.2(1.622)	200

Material

Nylon 66, UL94V-0, natural (white)

<For reference> As the color identification, the following alphabet shall be put in the underlined part.
For availability, delivery and minimum order quantity, contact JST.

ex. **XLP-02V-oo**

(blank)...natural (white)

K...black R...red E...blue Y...yellow

XL CONNECTOR

Contact position location numbers

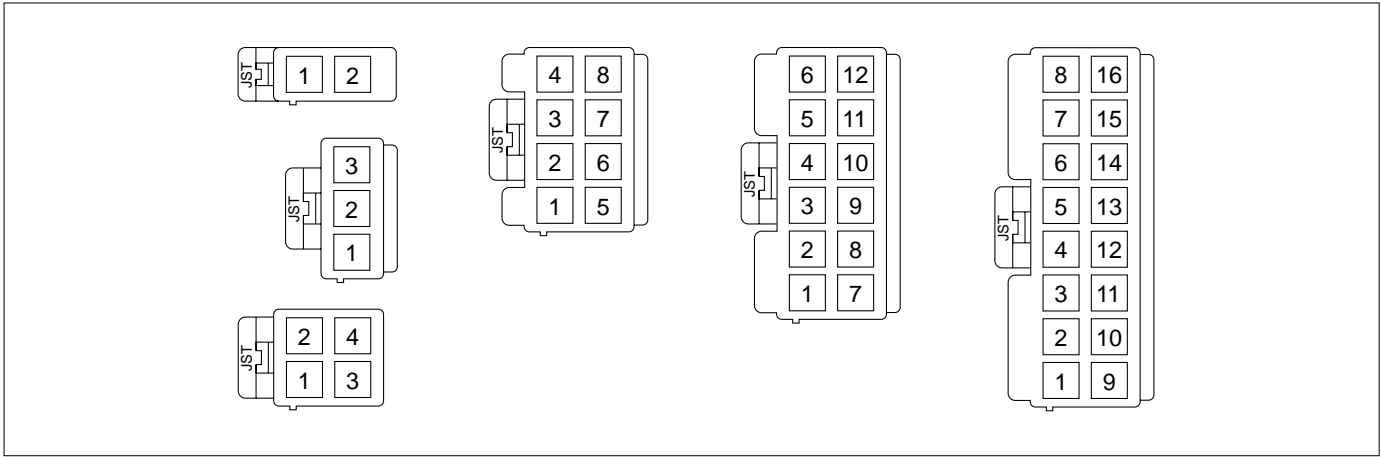

Locking header

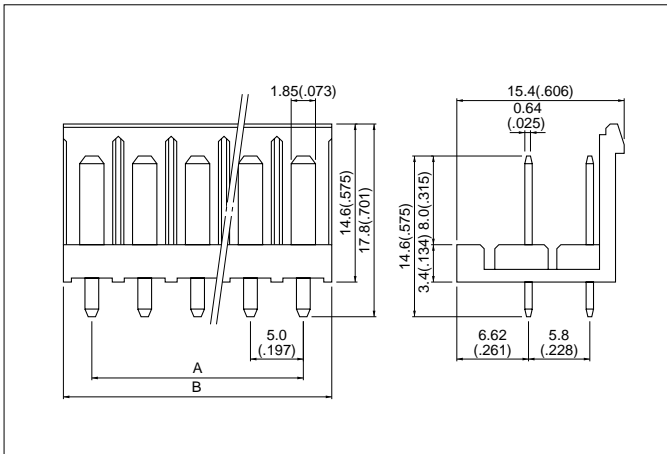

Circuits	Model No.	Dimensions mm(in.)		Q'ty / box
		A	B	
2	B02P-XL	—	5.0(.197)	250
4	B04P-XL	5.0(.197)	10.0(.394)	200
8	B08P-XL	15.0(.591)	20.0(.787)	100
12	B12P-XL	25.0(.984)	30.0(1.181)	50
16	B16P-XL	35.0(1.378)	40.0(1.575)	50

Material and Finish

Post: Brass, copper-undercoated, tin/lead-plated
Wafer: Nylon 66, UL94V-0, natural (white)

<For reference> As the color identification, the following alphabet shall be put in the underlined part. For availability, delivery and minimum order quantity, contact JST.

ex. **B02P-XL-oo**
(blank)...natural (white)
K...black R...red E...blue Y...yellow

Locking header PC board layout (viewed from soldering side) and Assembly layout

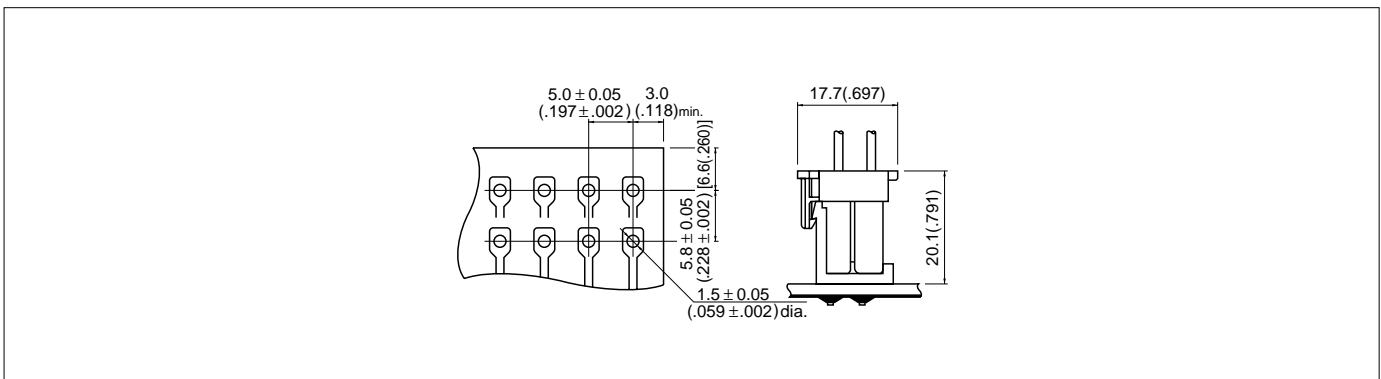

Note:
1. Tolerances are non-cumulative: $\pm 0.05\text{mm}(\pm .002")$ for all centers.
2. Hole dimensions differ according to the kind of PC board and piercing method. The dimensions above should serve as a guideline. Contact JST for details.

Shrouded header <HDB type>

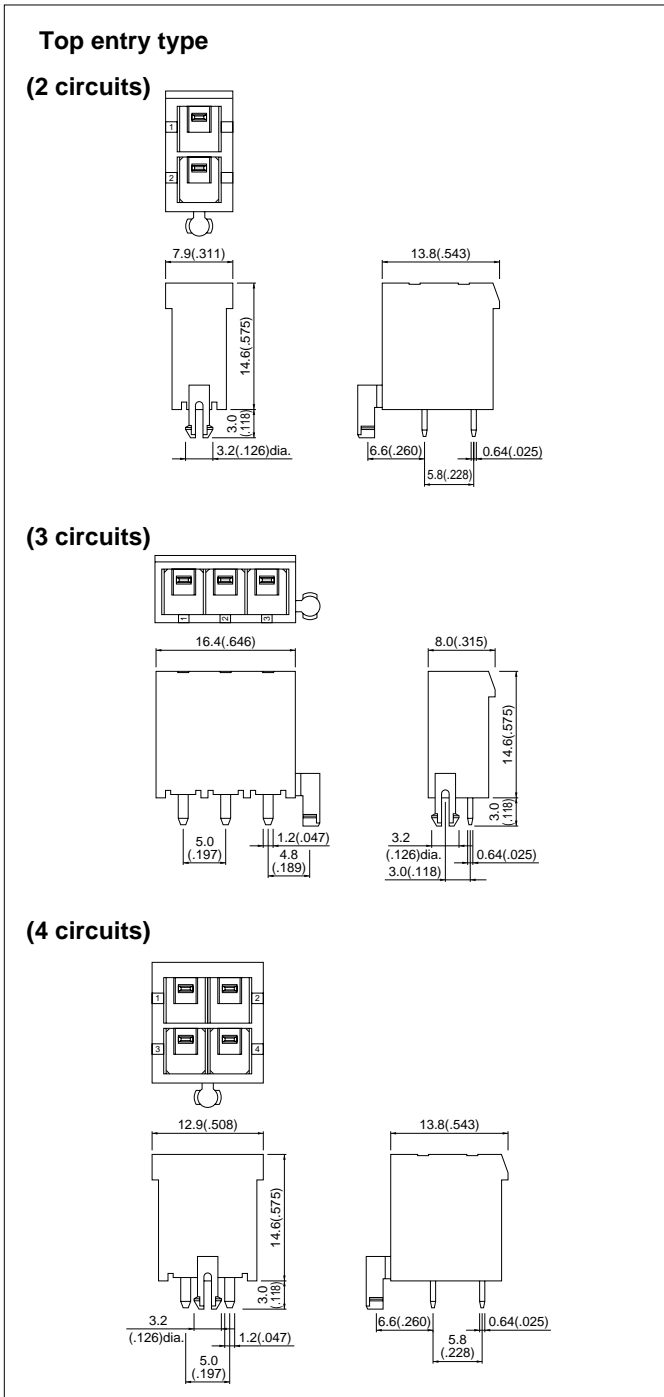

Circuits	Model No.	Qty / box
2	B02P-XL-HDB	200
3	B03P-XL-HDB	200
4	B04P-XL-HDB	200

Material and Finish

Post: Brass, copper-undercoated, tin/lead-plated
 Wafer: Nylon 66, UL94V-0, natural (white)

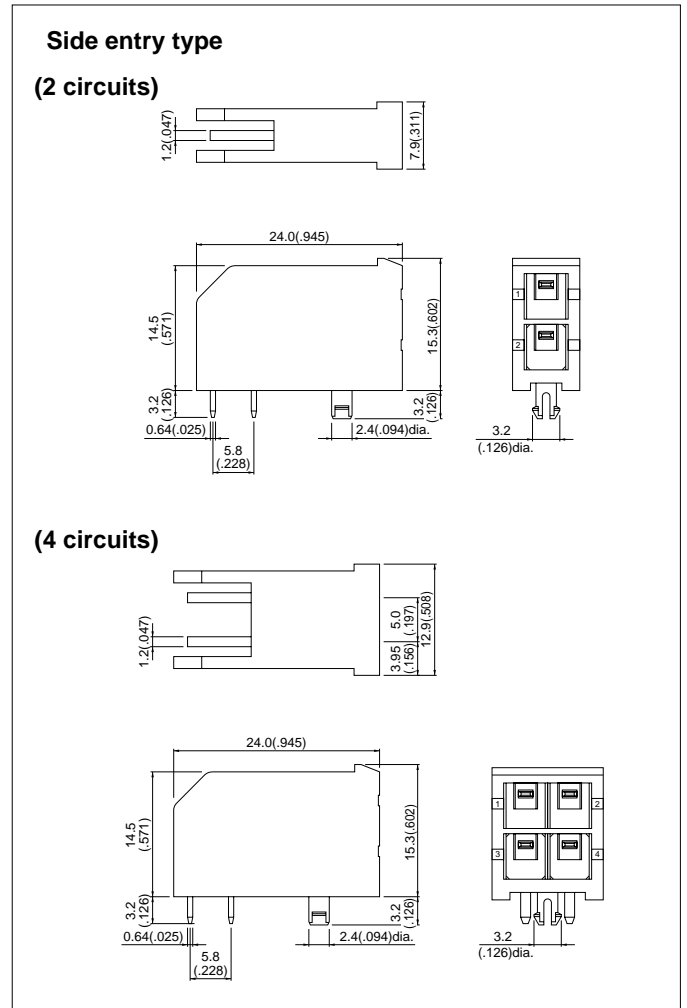

Circuits	Model No.	Qty / box
2	S02P-XL-HDB	100
4	S04P-XL-HDB	100

Material and Finish

Post: Brass, copper-undercoated, tin/lead-plated
 Wafer: Nylon 66, UL94V-0, natural (white)

<For reference> As the color identification, the following alphabet shall be put in the underlined part. For availability, delivery and minimum order quantity, contact JST.

ex. **B02P-XL-HDB-oo**, **S02P-XL-HDB-oo**
 (blank)...natural (white)
 K...black R...red E...blue Y...yellow

XL CONNECTOR

Shrouded header <HDS type>

Top entry type

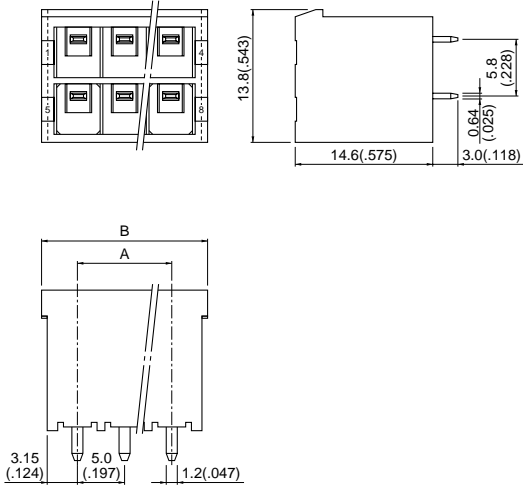

Side entry type

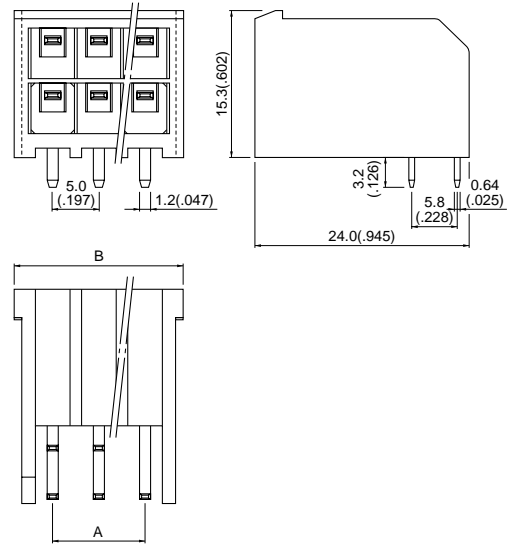

Cir- cuits	Model No.	Dimensions mm(in.)		Q'ty / box
		A	B	
2	B02P-XL-HDS	—	7.9(.311)	200
4	B04P-XL-HDS	5.0(.197)	12.9(.508)	200
8	B08P-XL-HDS	15.0(.591)	22.9(.902)	100
12	B12P-XL-HDS	25.0(.984)	32.9(1.295)	50
16	B16P-XL-HDS	35.0(1.378)	42.9(1.689)	40

Material and Finish

Post: Brass, copper-undercoated, tin/lead-plated
Wafer: Nylon 66, UL94V-0, natural (white)

Cir- cuits	Model No.	Dimensions mm(in.)		Q'ty / box
		A	B	
8	S08P-XL-HDS	15.0(.591)	22.9(.902)	40
12	S12P-XL-HDS	25.0(.984)	32.9(1.295)	30
16	S16P-XL-HDS	35.0(1.378)	42.9(1.689)	20

Material and Finish

Post: Brass, copper-undercoated, tin/lead-plated
Wafer: Nylon 66, UL94V-0, natural (white)

<For reference> As the color identification, the following alphabet shall be put in the underlined part. For availability, delivery and minimum order quantity, contact JST.

ex. **B08P-XL-HDS-oo**, **S08P-XL-HDS-oo**
(blank)...natural (white)
K...black R...red E...blue Y...yellow

Shrouded header PC board layout (viewed from component side)

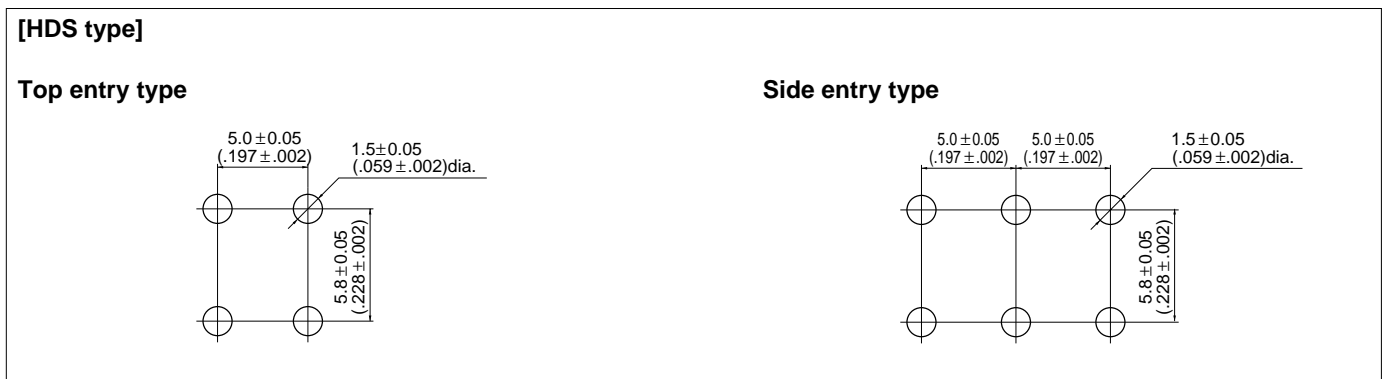
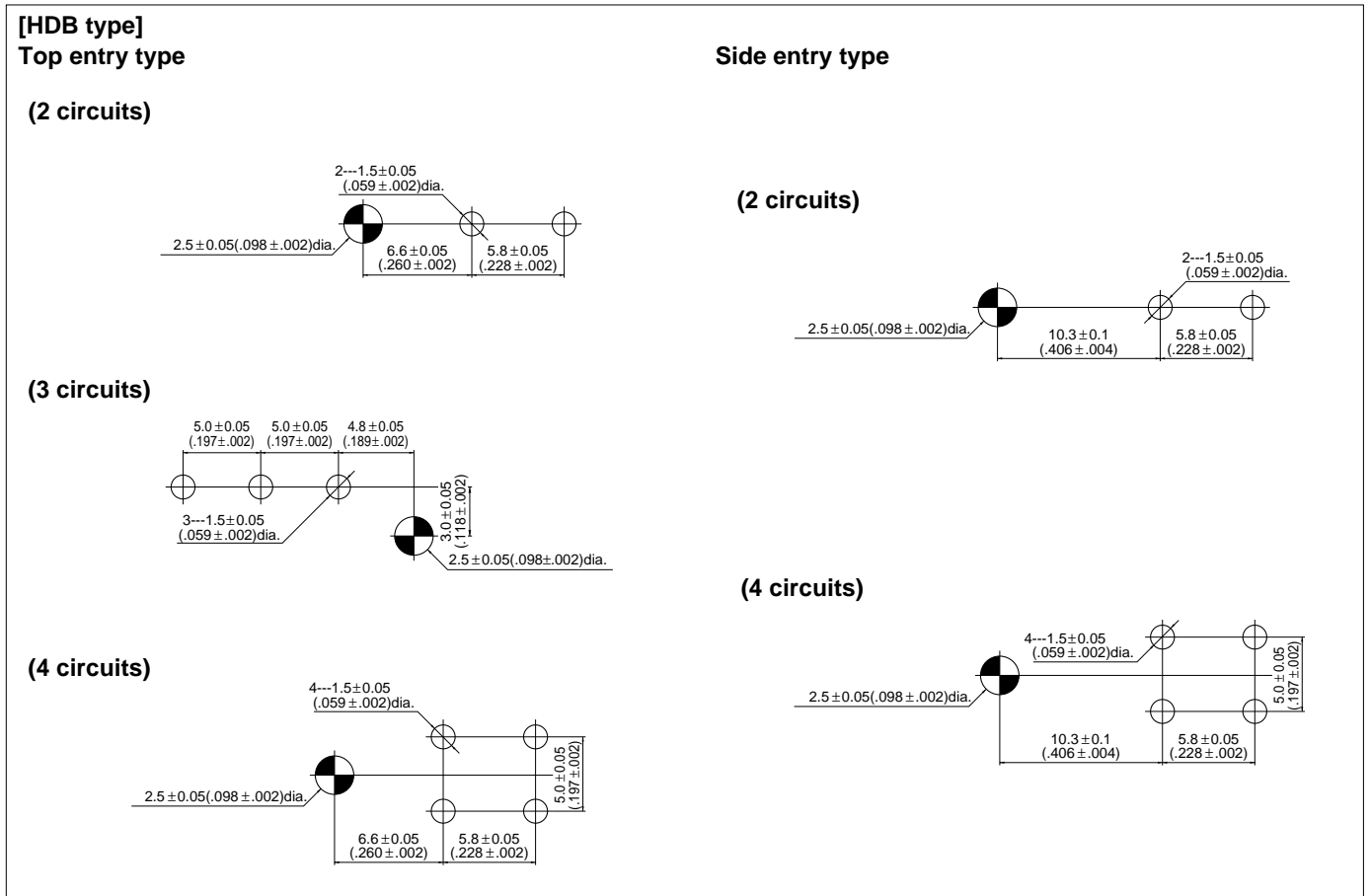

Note:

1. Tolerances are non-cumulative: $\pm 0.05\text{mm}$ ($\pm .002''$) for all centers.
2. Hole dimensions differ according to the kind of PC board and piercing method.
The dimensions above should serve as a guideline. Contact JST for details.

Applicator for the semi-automatic press AP-K2N

Contact	Crimp applicator MKS-L		Compact crimp applicator MKS-LS		Strip-crimp applicator MKS-SC
	with safety cover	without safety cover	with safety cover	without safety cover	with safety cover
SXF-01T-P0.7	APLMK SXF01-07	APLNC SXF01-07	-	-	-
SXF-41T-P0.7	APLMK SXF41-07	APLNC SXF41-07	-	-	-