

SERIES 101 STANDARD DIP SOCKET (OPEN FRAME)

102 DIP SOCKET WITHOUT CROSSBARS (OPEN FRAME)

WAFER CHART			
	PIN	DIM "A"	
FIG. 1	6	.300 [7.62]	306
	8	.400 [10.16]	308
	10	.500 [12.70]	310
FIG. 2	14	.700 [17.78]	314
	16	.800 [20.32]	316
	18	.900 [22.86]	318
	20	1.000 [25.40]	320
	22	1.100 [27.94]	322
	24	1.200 [30.48]	324
FIG. 3	28	1.400 [35.56]	328
	16	.800 [20.32]	416
	22	1.100 [27.94]	422
FIG. 4	24	1.200 [30.48]	424
	28	1.400 [35.56]	428
FIG. 5	30	1.500 [38.10]	430
	32	1.600 [40.64]	432
	36	1.800 [45.72]	436
	40	2.000 [50.80]	440
	48	2.400 [60.96]	448
	50	2.500 [63.50]	450
FIG. 6	52	2.600 [66.04]	452
	64	3.200 [81.28]	464

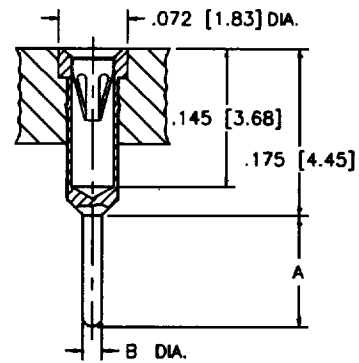
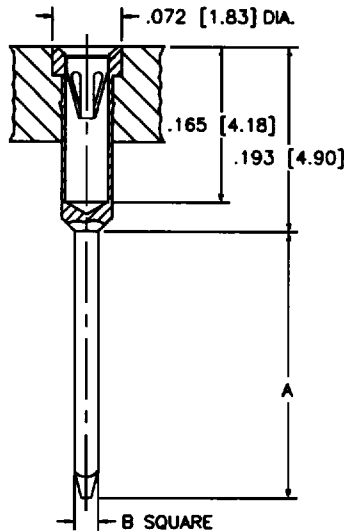
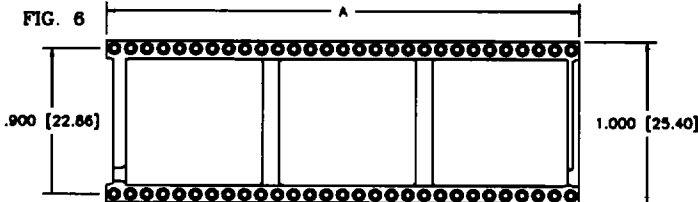
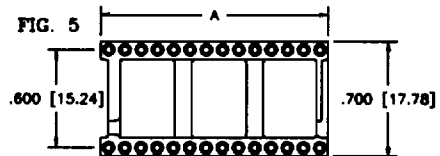
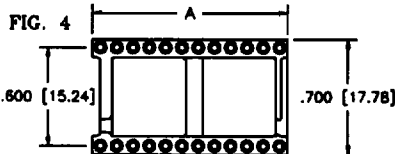
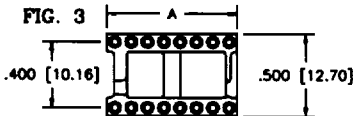
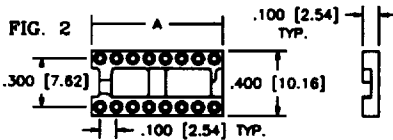
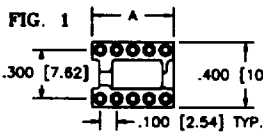

FIG. D

FIG. C

TERMINAL STYLE			
TERMINAL	FIG.	DIM "A"	DIM "B"
-01	D	.115 [2.92]	.020 [0.51]
-02	C	.370 [9.40]	.025 [0.64]
-03	C	.510 [12.95]	.025 [0.64]
-08	D	.170 [4.31]	.020 [0.51]
-09	D	.280 [7.11]	.020 [0.51]
-11	D	.135 [3.43]	.020 [0.51]
-94	D	.125 [3.17]	.018 [0.46]



CONTACT TYPE

S: STANDARD DIP	INSERTION FORCE	9.0 oz. AVG.
	WITHDRAWAL FORCE	2.0 oz. MIN.
M: STANDARD PGA	INSERTION FORCE	1.6 oz. MAX.
	WITHDRAWAL FORCE	0.5 oz. MIN.
L: INTERSTITIAL PGA	INSERTION FORCE	1.0 oz. MAX.
	WITHDRAWAL FORCE	0.3 oz. MIN.
H: HIGH FORCE	INSERTION FORCE	18.3 oz. MAX.
	WITHDRAWAL FORCE	4.2 oz. MIN.

TECHNICAL SPECIFICATIONS

MATERIAL INSULATOR GLASS FILLED POLYESTER
UL 94V-0 LISTED

TERMINAL CONTACT BRASS PER ASTM-B16
BeCu PER ASTM-B194

OPERATING TEMP. -65°C TO +125°C

CONTACT FORCES

INSERTION	STANDARD	9 oz. AVG.
WITHDRAWAL	STANDARD	2 oz. MIN.

ORDERING INFORMATION

