



**MCOTS-C-28-50-HZ**

**Single Output**

**Half-brick**

## MILITARY COTS DC/DC CONVERTER

<b>16-40V</b> Continuous Input	<b>16-50V</b> Transient Input	<b>50V</b> Output	<b>10A</b> Output	<b>95% @ 5A / 94% @ 10A</b> Efficiency
-----------------------------------	----------------------------------	----------------------	----------------------	---

**Full Power Operation: -55°C to +100°C**

The MilQor series of Mil-COTS DC/DC converters brings SynQor's field proven high-efficiency synchronous rectification technology to the Military/Aerospace industry. SynQor's ruggedized encased packaging approach ensures survivability in demanding environments. Compatible with the industry standard format, these converters operate at a fixed frequency, and follow conservative component derating guidelines. They are designed and manufactured to comply with a wide range of military standards.

## Mil-COTS



**Designed and Manufactured in the USA**

### Operational Features

- High efficiency, 94% at full rated load current
- Operating input voltage range: 16-40V
- Fixed frequency switching provides predictable EMI
- No minimum load requirement

### Mechanical Features

- Industry standard half-brick pin-out configuration
- Size: 2.49" x 2.39" x 0.51"  
(63.1 x 60.6 x 13.0 mm)
- Total weight: 4.9 oz. (139 g)
- Flanged baseplate version available

### Control Features

- On/Off control referenced to input return
- Remote sense for the output voltage
- Wide output voltage trim range of +10%, -50%
- Optional: Active current share for parallel applications

### Safety Features

- 2250V, 30 MΩ input-to-output isolation
- Certified 60950-1 requirement for basic insulation (see Standards and Qualifications page)

### Protection Features

- Input under-voltage lockout
- Output current limit and short circuit protection
- Active back bias limit
- Auto-recovery output over-voltage protection
- Thermal shutdown

### Screening/Qualification

- AS9100 and ISO 9001:2008 certified facility
- Qualification consistent with MIL-STD-883
- Available with S-Grade or M-Grade screening
- Temperature cycling per MIL-STD-883, Method 1010, Condition B, 10 cycles
- Burn-In at 100C baseplate temperature
- Final visual inspection per MIL-STD-2008
- Full component traceability

### BLOCK DIAGRAM

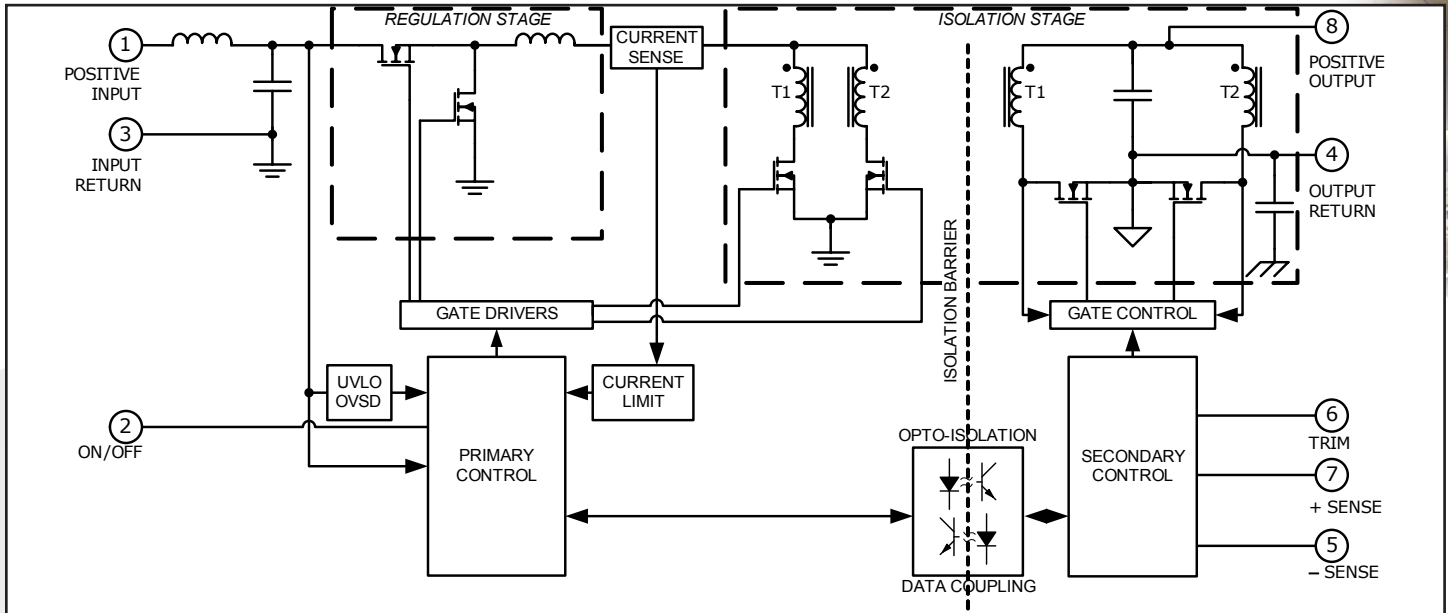

### TYPICAL CONNECTION DIAGRAM

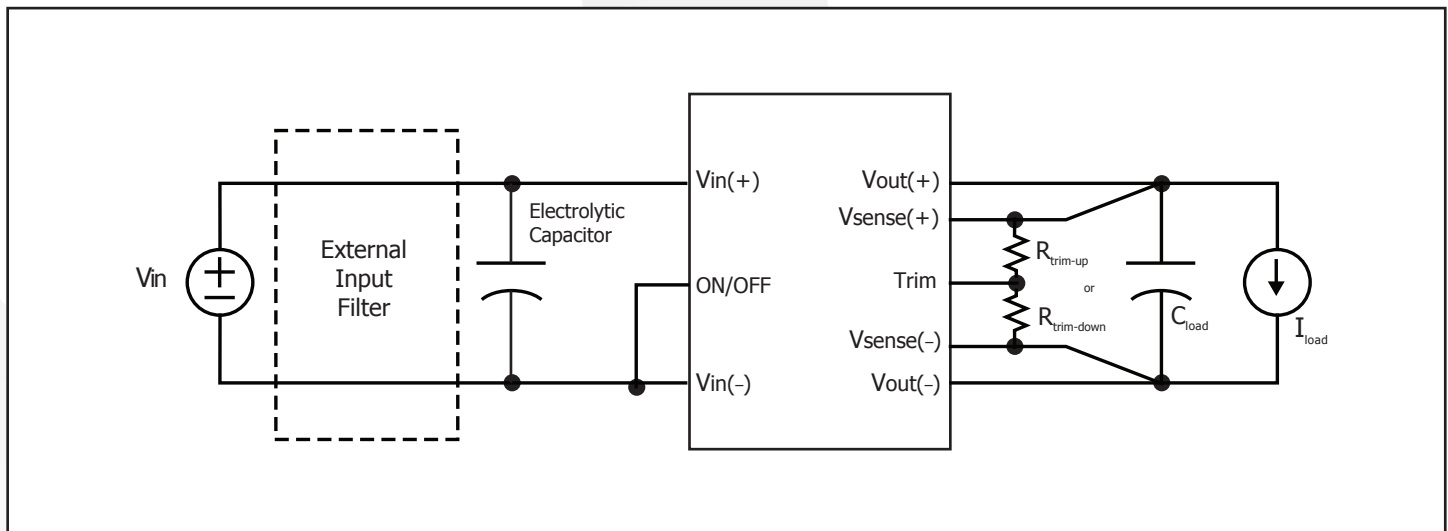



# Technical Specification

**MCOTS-C-28-50-HZ**

**Output: 50V**

**Current: 10A**

## MCOTS-C-28-50-HZ ELECTRICAL CHARACTERISTICS

Ta = 25 °C, Vin = 28dc unless otherwise noted; full operating temperature range is -55 °C to +100 °C baseplate temperature with appropriate power derating. Specifications subject to change without notice.

Parameter	Min.	Typ.	Max.	Units	Notes & Conditions
<b>ABSOLUTE MAXIMUM RATINGS</b>					
Input Voltage					
Non-Operating			50	V	Continuous
Operating			40	V	Continuous
Operating Transient Protection			50	V	100 ms transient, square wave
Isolation Voltage					
Input to Output			2250	Vdc	Basic Insulation, Pollution Degree 2
Input to Base-Plate			2250	Vdc	
Output to Base-Plate			2250	Vdc	
Operating Temperature	-55		100	°C	Baseplate temperature
Storage Temperature	-65		135	°C	
Voltage at ON/OFF input pin	-2		18	V	
<b>INPUT CHARACTERISTICS</b>					
Operating Input Voltage Range	16	28	40	V	50V transient for 100 ms
Input Under-Voltage Lockout					
Turn-On Voltage Threshold	15.1	15.4	15.7	V	
Turn-Off Voltage Threshold	14.2	14.5	14.8	V	
Lockout Voltage Hysteresis	0.5	0.9	1.5	V	
Recommended External Input Capacitance		470		µF	Typical ESR 0.1-0.2 Ω
Input Filter Component Values (L\C)		0.34\23		µH\µF	Internal values; see Figure E
Maximum Input Current			41.0	A	At Low Line, Full Load and Trimmed up 10%
No-Load Input Current		340	430	mA	
Disabled Input Current		100	125	mA	
Response to Input Transient		1.5		V	0.25 V/µs input transient
Input Terminal Ripple Current		500		mA	RMS
Recommended Input Fuse			40	A	Fast blow external fuse recommended
<b>OUTPUT CHARACTERISTICS</b>					
Output Voltage Set Point	49.18	50	50.70	V	
Output Voltage Regulation					See Note 1
Over Line		±0.25\125		%\mV	
Over Load		±0.25\125		%\mV	
Over Temperature		±0.380	±1.250	V	
Total Output Voltage Range	48.50		51.50	V	Over sample, line, load, temperature & life
Output Voltage Ripple and Noise					20 MHz bandwidth; See Note 2
Peak-to-Peak		250	300	mV	Full Load
RMS		60	75	mV	Full Load
Operating Output Current Range	0		10	A	Subject to thermal derating
Output DC Current-Limit Inception	11	12	13	A	Output Voltage 10% Low
Output DC Current-Limit Shutdown Voltage		20		V	See Note 3
Back-Drive Current Limit while Enabled	2	3	4	A	Negative current drawn from output
Back-Drive Current Limit while Disabled	0	3	7	mA	Negative current drawn from output
Maximum Output Capacitance			1	mF	10 A Resistive Load
Output Voltage during Load Current Transient					
Step Change in Output Current (0.1 A-5 A/µs)		2		V	50% to 75% to 50% IOU max, 200 µF load cap
Settling Time		8		ms	To within 1% VOUT nom
Output Voltage Trim Range	-50		10	%	Across Pins 8 & 4; Figure C
Output Over-Voltage Protection	56.5	59	61.5	V	Over full temp range
<b>EFFICIENCY</b>					
100% Load		94		%	See Figure 1 for efficiency curve
50% Load		95		%	See Figure 1 for efficiency curve





# Technical Specification

**MCOTS-C-28-50-HZ**

**Output: 50V**

**Current: 10A**

## MCOTS-C-28-50-HZ ELECTRICAL CHARACTERISTICS

Ta = 25 °C, Vin = 28dc unless otherwise noted; full operating temperature range is -55 °C to +100 °C baseplate temperature with appropriate power derating. Specifications subject to change without notice.

Parameter	Min.	Typ.	Max.	Units	Notes & Conditions
<b>DYNAMIC CHARACTERISTICS</b>					
Turn-On Transient					
Turn-On Time	24	35	40	ms	Full load, Vout=90% nom.
Output Voltage Overshoot			2	%	No Load, 1mF load cap
<b>ISOLATION CHARACTERISTICS</b>					
Isolation Voltage (dielectric strength)		2250		V	
Isolation Resistance		30		MΩ	
Isolation Capacitance (input to output)		1000		pF	See Note 4
<b>TEMPERATURE LIMITS FOR POWER DERATING CURVES</b>					
Semiconductor Junction Temperature			125	°C	Package rated to 150 °C
Board Temperature			125	°C	UL rated max operating temp 130 °C
Transformer Temperature			125	°C	
Maximum Baseplate Temperature, Tb			100	°C	
<b>FEATURE CHARACTERISTICS</b>					
Switching Frequency	230	240	250	kHz	Isolation stage switching freq. is half this
ON/OFF Control					
Off-State Voltage	4		18	V	
On-State Voltage	-2		1	V	
ON/OFF Control					
Pull-Up Voltage	4.75	5	5.25	V	
Pull-Up Resistance		10		kΩ	
Over-Temperature Shutdown OTP Trip Point		120		°C	Average PCB Temperature
Over-Temperature Shutdown Restart Hysteresis		10		°C	
<b>RELIABILITY CHARACTERISTICS</b>					
Calculated MTBF (Telcordia) TR-NWT-000332		1.49		10 <sup>6</sup> Hrs.	Tb = 70 °C
Calculated MTBF (MIL-217) MIL-HDBK-217F		1.31		10 <sup>6</sup> Hrs.	Tb = 70 °C
Field Demonstrated MTBF		TBD		10 <sup>6</sup> Hrs.	

Note 1: Line and load regulation is limited by duty cycle quantization and does not indicate a shift in the internal voltage reference.

Note 2: For applications requiring reduced output voltage ripple and noise, consult SynQor applications support (e-mail: support@synqor.com).

Note 3: If the output voltage falls below the Output DC Current Limit Shutdown Voltage for more than 50ms, then the unit will enter into hiccup mode, with a 500ms off-time.

Note 4: Higher values of isolation capacitance can be added external to the module.

## STANDARDS COMPLIANCE

Parameter	Notes & Conditions
<b>STANDARDS COMPLIANCE</b>	
UL 60950-1:2003	Basic Insulation
CAN/CSA-C22.2 No. 60950-1:2003	
EN60950-1:2001	

Note: An external input fuse must always be used to meet these safety requirements. Contact SynQor for official safety certificates on new releases or download from the SynQor website.

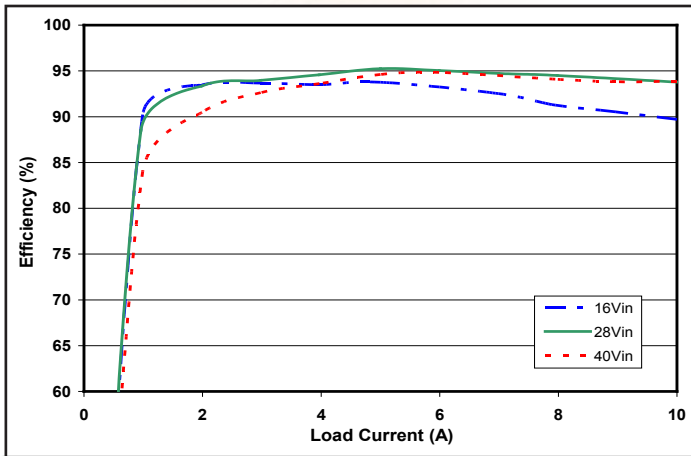

Figure 1: Efficiency at nominal output voltage vs. load current for minimum, nominal, and maximum input voltage at 25°C.

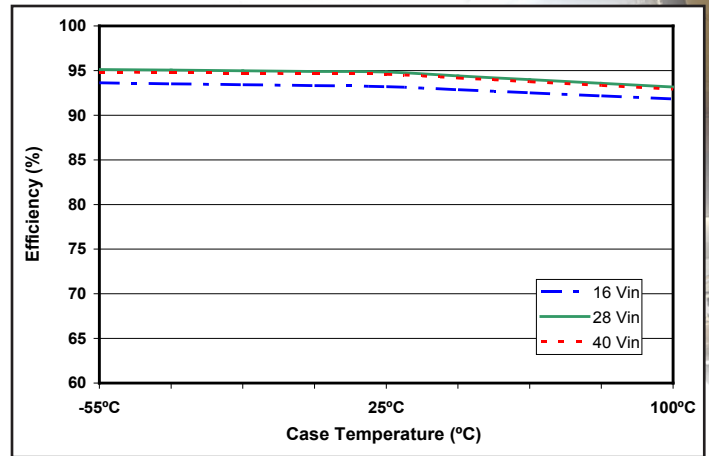

Figure 2: Efficiency at nominal output voltage and 60% rated power vs. case temperature for minimum, nominal, and maximum input voltage.

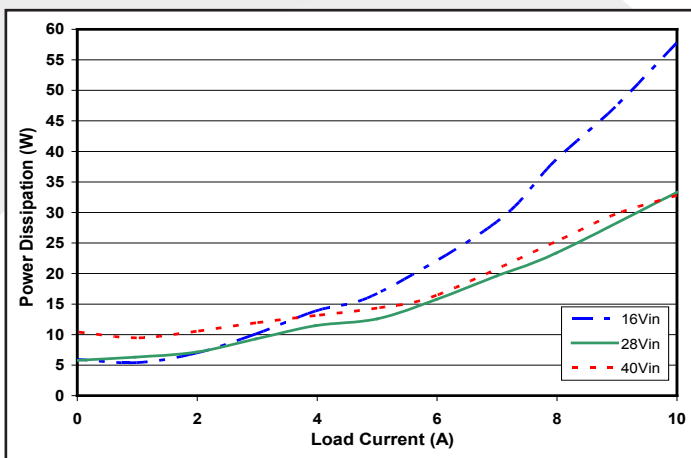

Figure 3: Power dissipation at nominal output voltage vs. load current for minimum, nominal, and maximum input voltage at  $T_{CASE}=25^{\circ}C$ .

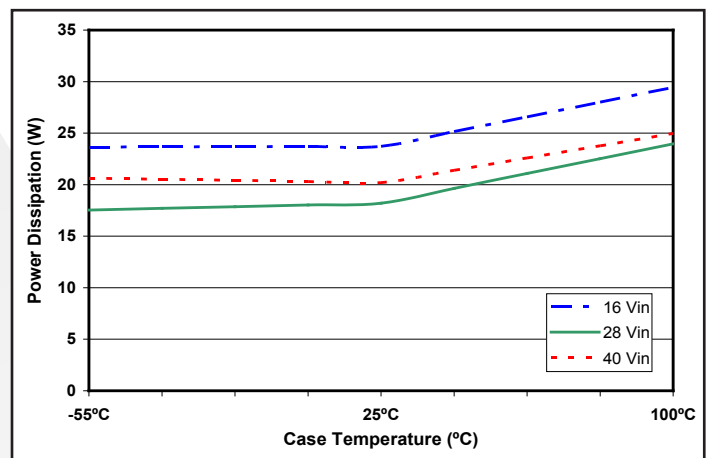

Figure 4: Power dissipation at nominal output voltage and 60% rated power vs. case temperature for minimum, nominal, and maximum input voltage.

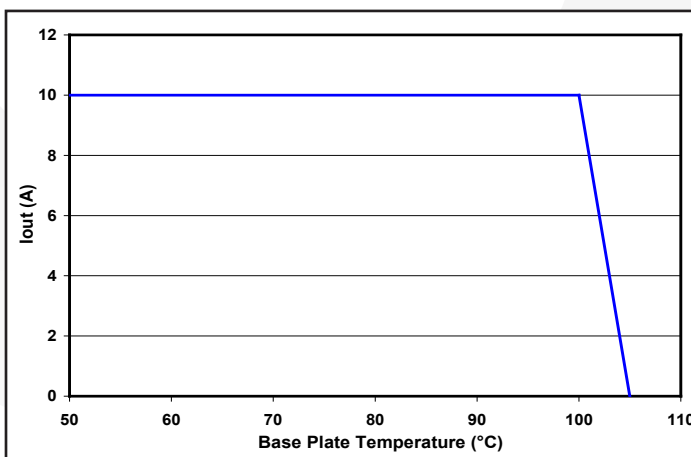

Figure 5: Maximum output current vs. base plate temperature (nominal input voltage).

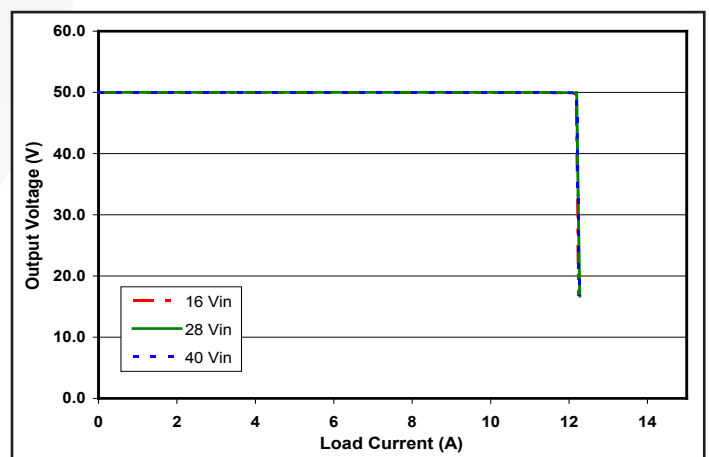

Figure 6: Output voltage vs. load current showing typical current limit curves. See Current Limit section in the Application Notes.

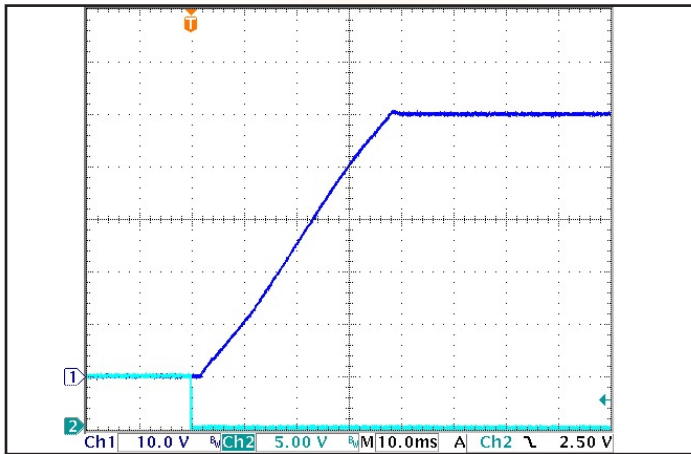

Figure 7: Typical startup waveform. Input voltage pre-applied, ON/OFF Pin on Ch 2.

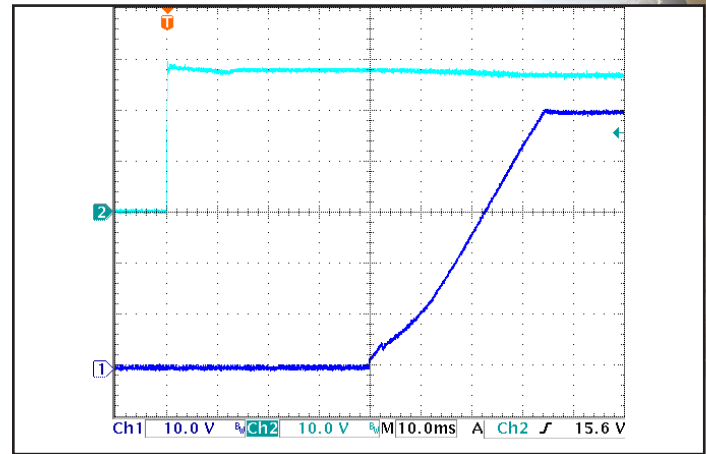

Figure 8: Turn-on transient at full resistive load and zero output capacitance initiated by  $V_{in}$ . ON/OFF Pin previously low. Ch 1:  $V_{in}$  (10V/div). Ch 2:  $V_{out}$  (10V/div).

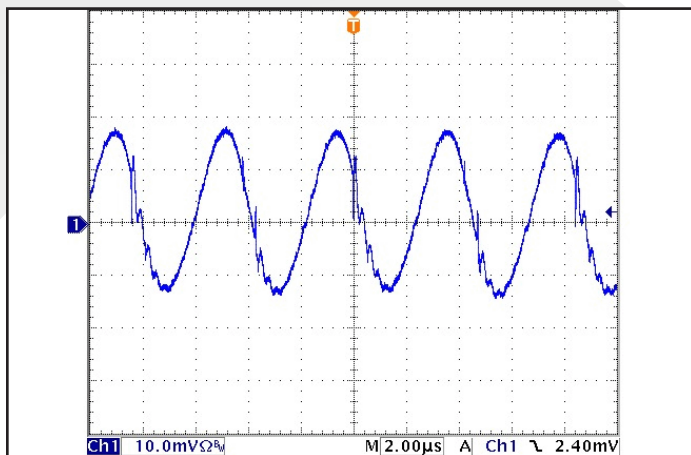

Figure 9: Input terminal current ripple,  $i_C$ , at full rated output current and nominal input voltage with SynQor MCOTS filter module (200 mA/div). Bandwidth: 20MHz. See Figure 17.

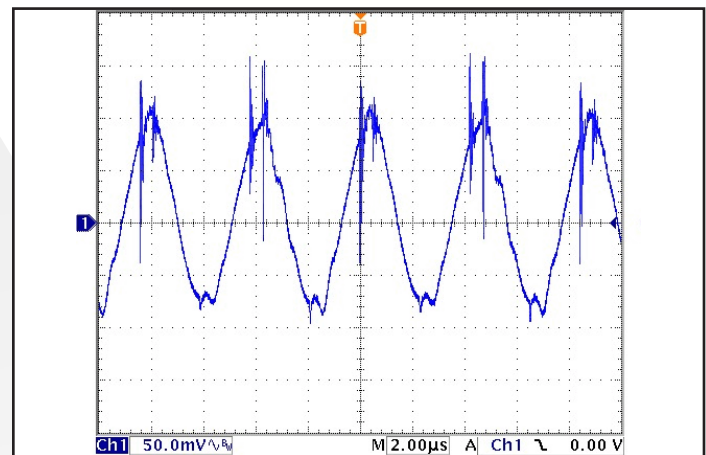

Figure 10: Output voltage ripple,  $V_{out}$ , at nominal input voltage and rated load current (50 mV/div). Load capacitance: 1µF ceramic capacitor and 10µF tantalum capacitor. Bandwidth: 10 MHz. See Figure 17.

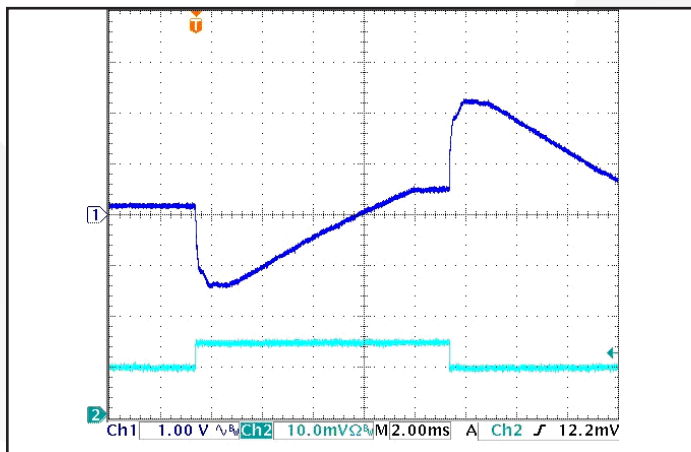

Figure 11: Output voltage response to step-change in load current (50%-75%-50% of  $I_{out(max)}$ ;  $dI/dt = 5 A/\mu s$ ). Load cap: 1 µF ceramic and 100 µF electrolytic capacitors. Ch 1:  $V_{out}$  (1V/div), Ch 2:  $I_{out}$  (5A/div).

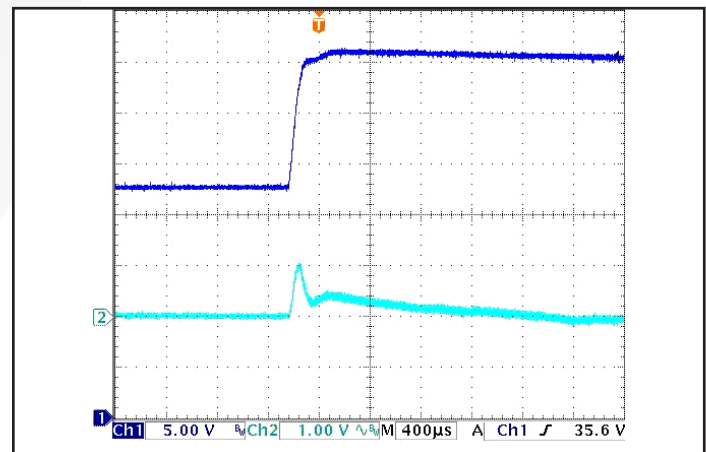

Figure 12: Output voltage response to step-change in input voltage (250V/ms). Load cap: 330 µF electrolytic output capacitance. Ch 1:  $V_{in}$  (5V/div), Ch 2:  $V_{out}$  (1V/div).



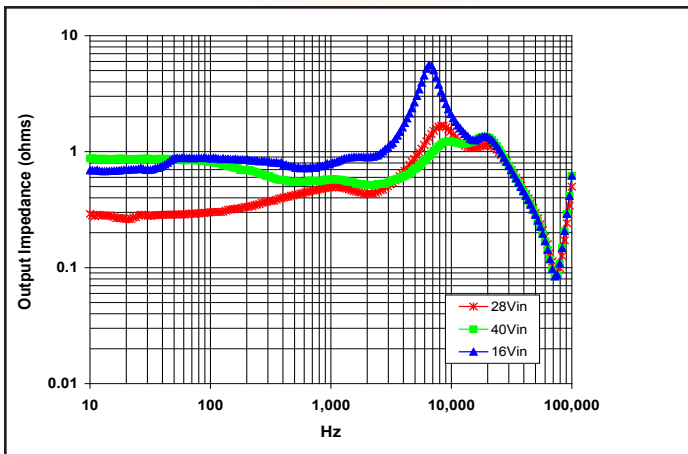

Figure 13: Magnitude of incremental output impedance ( $Z_{out} = v_{out}/i_{out}$ ) for minimum, nominal, and maximum input voltage at full rated power.

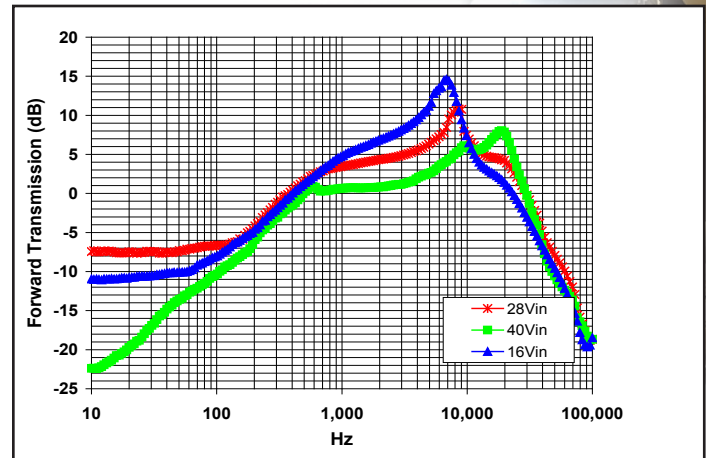

Figure 14: Magnitude of incremental forward transmission ( $FT = v_{out}/v_{in}$ ) for minimum, nominal, and maximum input voltage at full rated power.

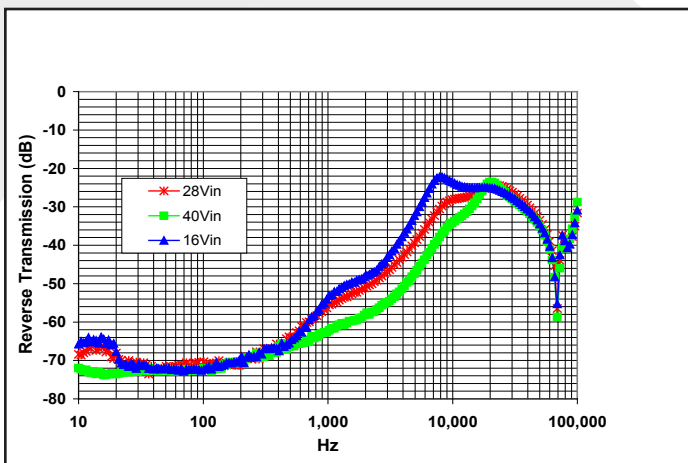

Figure 15: Magnitude of incremental reverse transmission ( $RT = i_{in}/i_{out}$ ) for minimum, nominal, and maximum input voltage at full rated power.

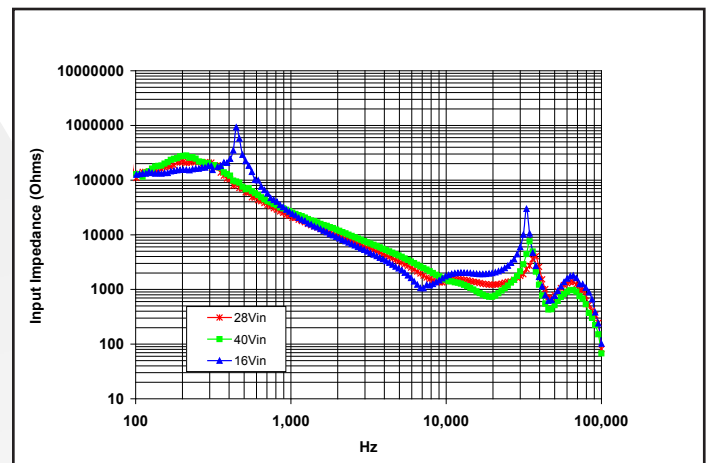

Figure 16: Magnitude of incremental input impedance ( $Z_{in} = v_{in}/i_{in}$ ) for minimum, nominal, and maximum input voltage at full rated power.

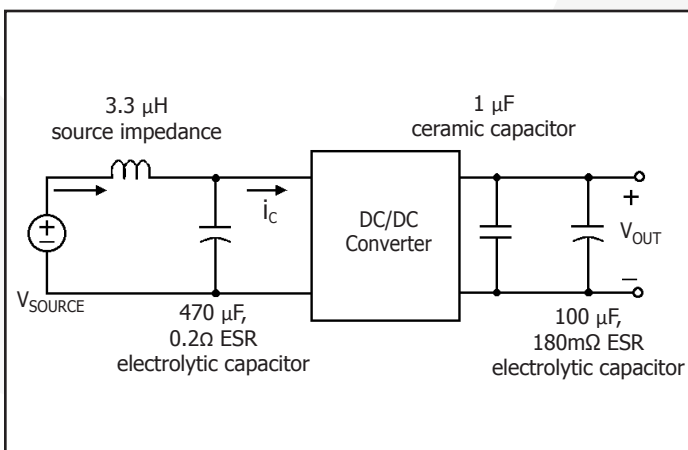

Figure 17: Test set-up diagram showing measurement points for Input Terminal Ripple Current (Figure 9) and Output Voltage Ripple (Figure 10).

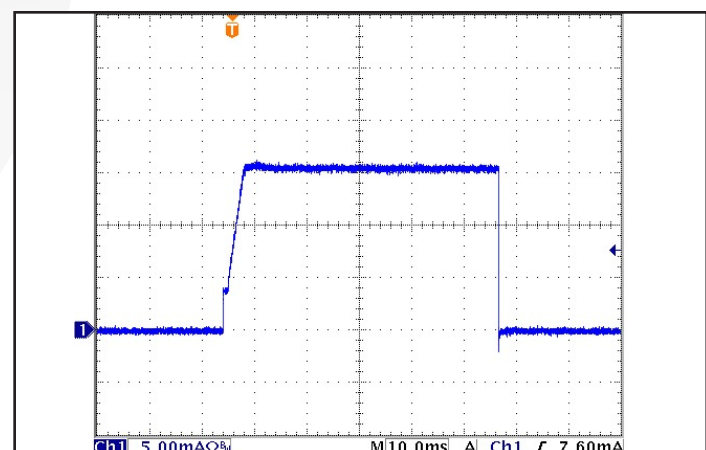

Figure 18: Load current (5A/div) as a function of time (10ms/div) when the converter attempts to turn on into a  $10 m\Omega$  short circuit.

### BASIC OPERATION AND FEATURES

The converter series uses a two-stage power conversion topology. The first stage keeps the output voltage constant over variations in line, load, and temperature. The second stage uses a transformer to provide the functions of input/output isolation and voltage step-down to achieve the low output voltage required.

Both the first stage and the second stage switch at a fixed frequency for predictable EMI performance. Rectification of the transformer's output is accomplished with synchronous rectifiers. These devices, which are MOSFETs with a very low on-state resistance, dissipate significantly less energy than Schottky diodes, enabling the converter to achieve high efficiency.

The series of half-brick, quarter-brick and eighth-brick converters uses the industry standard footprint and pin-out configuration.

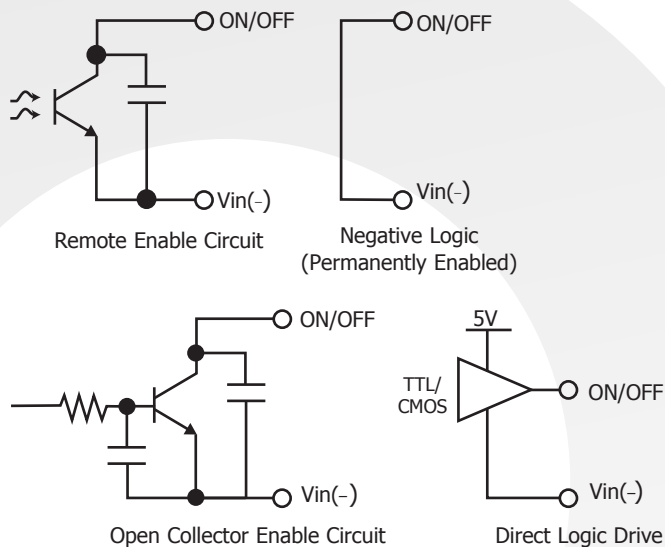

Figure A: Various circuits for driving the ON/OFF pin.

### CONTROL FEATURES

**REMOTE ON/OFF (Pin 2):** The ON/OFF input, Pin 2, permits the user to control when the converter is on or off. This input is referenced to the return terminal of the input bus, Vin(-).

The ON/OFF signal is active low (meaning that a low voltage turns the converter on). Figure A details four possible circuits for driving the ON/OFF pin.

**REMOTE SENSE(±) (Pins 8 and 6):** The SENSE(±) inputs correct for voltage drops along the conductors that connect the converter's output pins to the load.

Pin 8 should be connected to Vout(+) and Pin 6 should be connected to Vout(-) at the point on the board where regulation is desired. If these connections are not made, the converter will deliver an output voltage that is slightly higher than its specified value.

Note: The output over-voltage protection circuit senses the voltage across the sense leads (pins 8 and 6) to determine when it should trigger, not the voltage across the converter's output pins (pins 9 and 5).

**OUTPUT VOLTAGE TRIM (Pin 7):** The TRIM input permits the user to adjust the output voltage across the sense leads up or down according to the trim range specifications. SynQor uses industry standard trim equations.

To decrease the output voltage, the user should connect a resistor between Pin 7 (TRIM) and Pin 6 (SENSE(-) input). For a desired decrease of the nominal output voltage, the value of the resistor should be:

$$R_{\text{trim-down}} = \left( \frac{100\%}{\Delta} \right) - 2 \text{ k}\Omega$$

where

$$\Delta\% = \left| \frac{V_{\text{nominal}} - V_{\text{desired}}}{V_{\text{nominal}}} \right| \times 100\%$$



To increase the output voltage, the user should connect a resistor between Pin 7 (TRIM) and Pin 8 (SENSE(+) input). For a desired increase of the nominal output voltage, the value of the resistor should be

$$R_{\text{trim-up}} = \frac{\left( \frac{V_{\text{nominal}}}{1.225} - 2 \right) \times V_{\text{DES}} + V_{\text{NOM}}}{V_{\text{DES}} - V_{\text{NOM}}} \text{ k}\Omega$$

Figure B graphs the relationship between the trim resistor value, Rtrim-up and Rtrim-down, showing the total range the output voltage can be trimmed up or down.

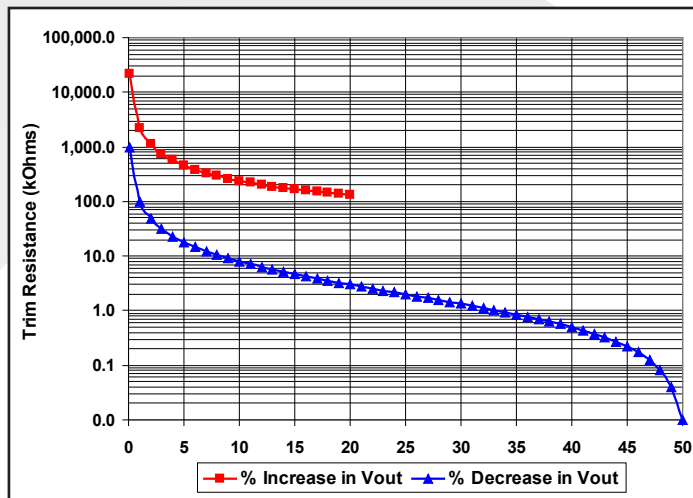

Figure B: Trim Graph for 28 Vout module

**Note:** The TRIM feature does not affect the voltage at which the output over-voltage protection circuit is triggered. Trimming the output voltage too high may cause the over-voltage protection circuit to engage, particularly during transients.

It is not necessary for the user to add capacitance at the Trim pin. The node is internally filtered to eliminate noise.

**Total DC Variation of Vout:** For the converter to meet its full specifications, the maximum variation of the DC value of Vout, due to both trimming and remote load voltage drops, should not be greater than that specified for the output voltage trim range.

## PROTECTION FEATURES

**Input Under-Voltage Lockout:** The converter is designed to turn off when the input voltage is too low, helping to avoid an input system instability problem, which is described in more detail in the application note titled "Input System Instability" on the SynQor website. The lockout circuitry is a comparator with DC hysteresis. When the input voltage is rising, it must exceed the typical "Turn-On Voltage Threshold" value\* before the converter will turn on. Once the converter is on, the input voltage must fall below the typical Turn-Off Voltage Threshold value before the converter will turn off.

**Output Current Limit:** If the output current exceeds the "Output DC Current Limit Inception" point\*, then a fast linear current limit controller will reduce the output voltage to maintain a constant output current. If as a result, the output voltage falls below the "Output DC Current Limit Shutdown Voltage"\* for more than 50 ms, then the unit will enter into hiccup mode, with a 500 ms off-time. The unit will then automatically attempt to restart.

**Back-Drive Current Limit:** If there is negative output current of a magnitude larger than the "Back-Drive Current Limit while Enabled" specification\*, then a fast back-drive limit controller will increase the output voltage to maintain a constant output current. If this results in the output voltage exceeding the "Output Over-Voltage Protection" threshold\*, then the unit will shut down. The full I-V output characteristics can be seen in Figure 15.

**Output Over-Voltage Limit:** If the voltage directly across the output pins exceeds the "Output Over-Voltage Protection" threshold\*, the converter will immediately stop switching. The converter will automatically attempt to restart with a 500ms off-time.

**Over-Temperature Shutdown:** A temperature sensor on the converter senses the average temperature of the module. The thermal shutdown circuit is designed to turn the converter off when the temperature at the sensed location reaches the "Over-Temperature Shutdown" value\*. It will allow the converter to turn on again when the temperature of the sensed location falls by the amount of the "Over-Temperature Shutdown Restart Hysteresis" value\*.

\* See Electrical Characteristics page.

### APPLICATION CONSIDERATIONS

**Input System Instability:** This condition can occur because any DC-DC converter appears incrementally as a negative resistance load. A detailed application note titled "Input System Instability" is available on the SynQor website which provides an understanding of why this instability arises, and shows the preferred solution for correcting it.

**Application Circuits:** Figure C below provides a typical circuit diagram which details the input filtering and voltage trimming.

**Input Filtering and External Input Capacitance:** Figure D below shows the internal input filter components. This filter dramatically reduces input terminal ripple current, which otherwise could exceed the rating of an external electrolytic input capacitor. The recommended external input capacitance is specified in the Input Characteristics section on the Electrical Specifications page. More detailed information is available in the application note titled "EMI Characteristics" on the SynQor website.

**Output Filtering and External Output Capacitance:** Figure D below shows the internal output filter components. This filter dramatically reduces output voltage ripple. However, some minimum external output capacitance is required, as specified in the Output Characteristics section on the Electrical Specifications page. No damage will occur without this capacitor connected, but peak output voltage ripple will be much higher.

**Thermal Considerations:** The maximum operating base-plate temperature,  $T_B$ , is 100 °C. As long as the user's thermal system keeps  $T_B \leq 100$  °C, the converter can deliver its full rated power.

A power derating curve can be calculated for any heatsink that is attached to the base-plate of the converter. It is only necessary to determine the thermal resistance,  $R_{THBA}$ , of the chosen heatsink between the base-plate and the ambient air for a given airflow rate. This information is usually available from the heatsink vendor. The following formula can be used to determine the maximum power the converter can dissipate for a given thermal condition if its base-plate is to be no higher than 100 °C.

$$P_{diss}^{max} = \frac{100 \text{ }^\circ\text{C} - T_A}{R_{THBA}}$$

This value of power dissipation can then be used in conjunction with the data shown in Figure 2 to determine the maximum load current (and power) that the converter can deliver in the given thermal condition.

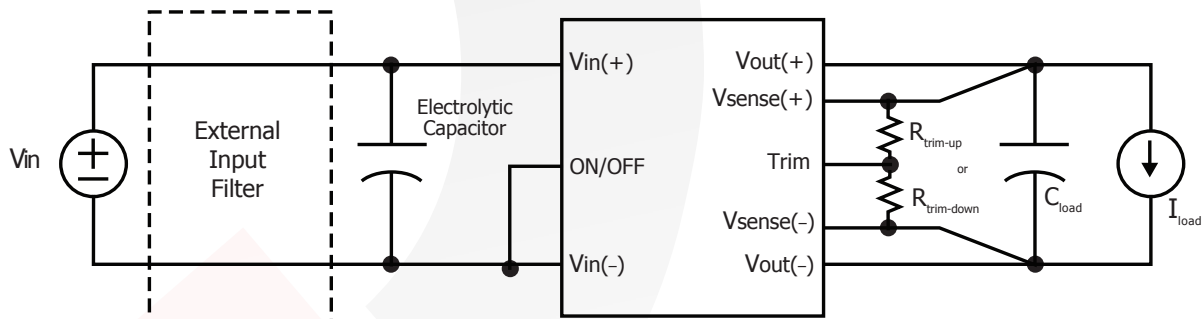

Figure C: Typical application circuit (negative logic unit, permanently enabled).

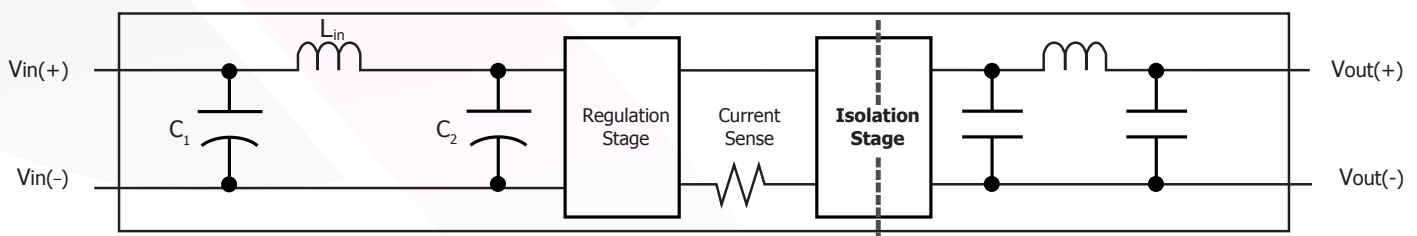

Figure D: Internal Input and Output Filter Diagram (component values listed on specifications page).

### Full-Featured Application Notes

With the full-featured option, specified by an "F" in the last character in the part number, current sharing operation is supported

**Connection of Paralleled Units:** Up to 100 units can be placed in parallel. In this current share architecture, one unit is dynamically chosen to act as a master, controlling all other units. It cannot be predicted which unit will become the master at any given time, so units should be wired symmetrically (see fig E).

- Input power pins and output power pins should be tied together between units, preferably with wide overlapping copper planes.
- The SHARE(+) and SHARE(-) pins should be routed between all paralleled units as a differential pair.
- The ON/OFF pins should be connected in parallel.
- The SENSE(+) and SENSE(-) pins should be connected either locally at each unit or separately to a common sense point.
- If the TRIM pin is used, then each unit should have its own trim resistor connected locally between TRIM and SENSE(+)

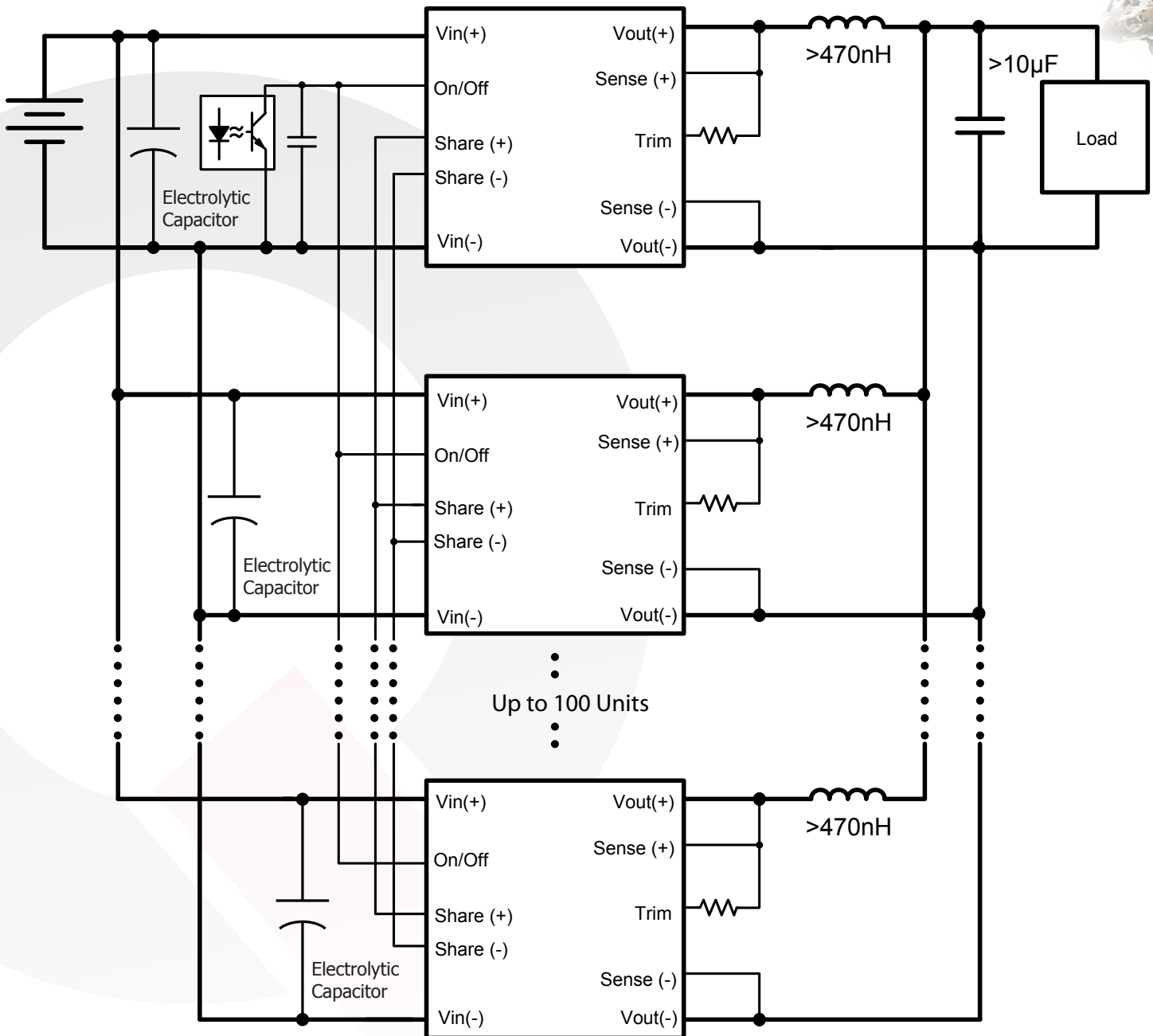

**Figure E:** Typical application circuit for paralleling of full-featured units



**Automatic Configuration:** The micro-controller inside each power converter unit is programmed at the factory with a unique serial number. In every other respect, each shared unit is identical and has the same orderable part number.

On initial startup (or after the master is disabled or shuts down), each unit determines the serial number of every other unit currently connected to the shared serial bus formed by the SHARE(+) and SHARE(-) pins. The unit with the highest serial number dynamically reconfigures itself from slave to master. The rest of the units (that do not have the highest serial number) become slaves.

The master unit then broadcasts its control state over the shared serial bus on a cycle-by-cycle basis. The slave units interpret and implement the control commands sent by the master, mirroring every action of the master unit.

If the master is disabled or encounters a fault condition, all units will immediately shut down, and if the master unit is unable to restart, then the unit with the next highest serial number will become master. If a slave unit is disabled or encounters a fault condition, all other units continue to run, and the slave unit can restart seamlessly.

**Automatic Interleaving:** The slave units automatically lock frequency with the master, and interleave the phase of their switching transitions for improved EMI performance. To obtain the phase angle relative to the master, each slave divides 360 degrees by the total number of connected units, and multiplies the result by its rank among serial numbers of connected units.

**Resonance between Output Capacitors is Possible:** When units are interleaved, it is possible to excite a series resonance between the output capacitors on two units and the air core inductance formed by the output pins. This is especially likely at higher output voltages where the on-board capacitance is relatively small. The problem is independent of external output capacitance. To ensure that this resonant frequency is below the switching frequency, for output voltages above 18V, it is recommended to add at least 470nH of inductance in series with each converter output.

**RS-485 Physical Layer:** The internal RS-485 transceiver includes many advanced protection features for enhanced reliability:

- Current Limiting and Thermal Shutdown for Driver Overload Protection
- IEC61000 ESD Protection to +/- 16.5kV
- Hot Plug Circuitry – SHARE(+) and SHARE(-) Outputs Remain Tri-State During Power-up/Power-down

**Internal Schottky Diode Termination:** Despite signaling at high speed with fast edges, external termination resistors are not necessary. Each receiver has four Schottky diodes built in, two for each line in the differential pair. These diodes clamp any ringing caused by transmission line reflections, preventing the voltage from going above about 5.5 V or below about -0.5 V. Any subsequent ringing then inherently takes place between 4.5 and 5.5 V or between -0.5 and 0.5 V. Since each receiver on the bus contains a set of clamping diodes to clamp any possible transmission line reflection, the bus does not necessarily need to be routed as a daisy-chain.

Pins SHARE(+) and SHARE(-) are referenced to Vin(-), and therefore should be routed as a differential pair near the Vin(-) plane for optimal signal integrity. The maximum difference in voltage between Vin(-) pins of all units on the share-bus should be kept within 0.3V to prevent steady-state conduction of the termination diodes, which would cause increased power dissipation and reduced noise margin.

**Share Accuracy:** Inside the converter micro-controller, the duty cycle is generated digitally with 1ns resolution. This allows for excellent duty cycle matching between connected units. Some small duty cycle mismatch is caused by (well controlled) process variations in the MOSFET gate drivers. However, the voltage difference induced by this duty cycle mismatch appears across the impedance of the entire power converter, from input to output, multiplied by two, since the differential current flows out of one converter and into another. So, a small duty cycle mismatch yields very small differential currents, which remain small even when 100 units are placed in parallel.

In other current-sharing schemes, it is common to have a current-sharing control loop in each unit. However, due to the limited bandwidth of this loop, units do not necessarily share current on startup or during transients before this loop has a chance to respond. In contrast, the current-sharing scheme used in this product has no control dynamics: control signals are transmitted fast enough that the slave units can mirror the control state of the master unit on a cycle-by-cycle basis, and the current simply shares properly, from the first switching cycle to the last.

## Technical Specification

### Mechanical Drawing – Normal Heatsink Option

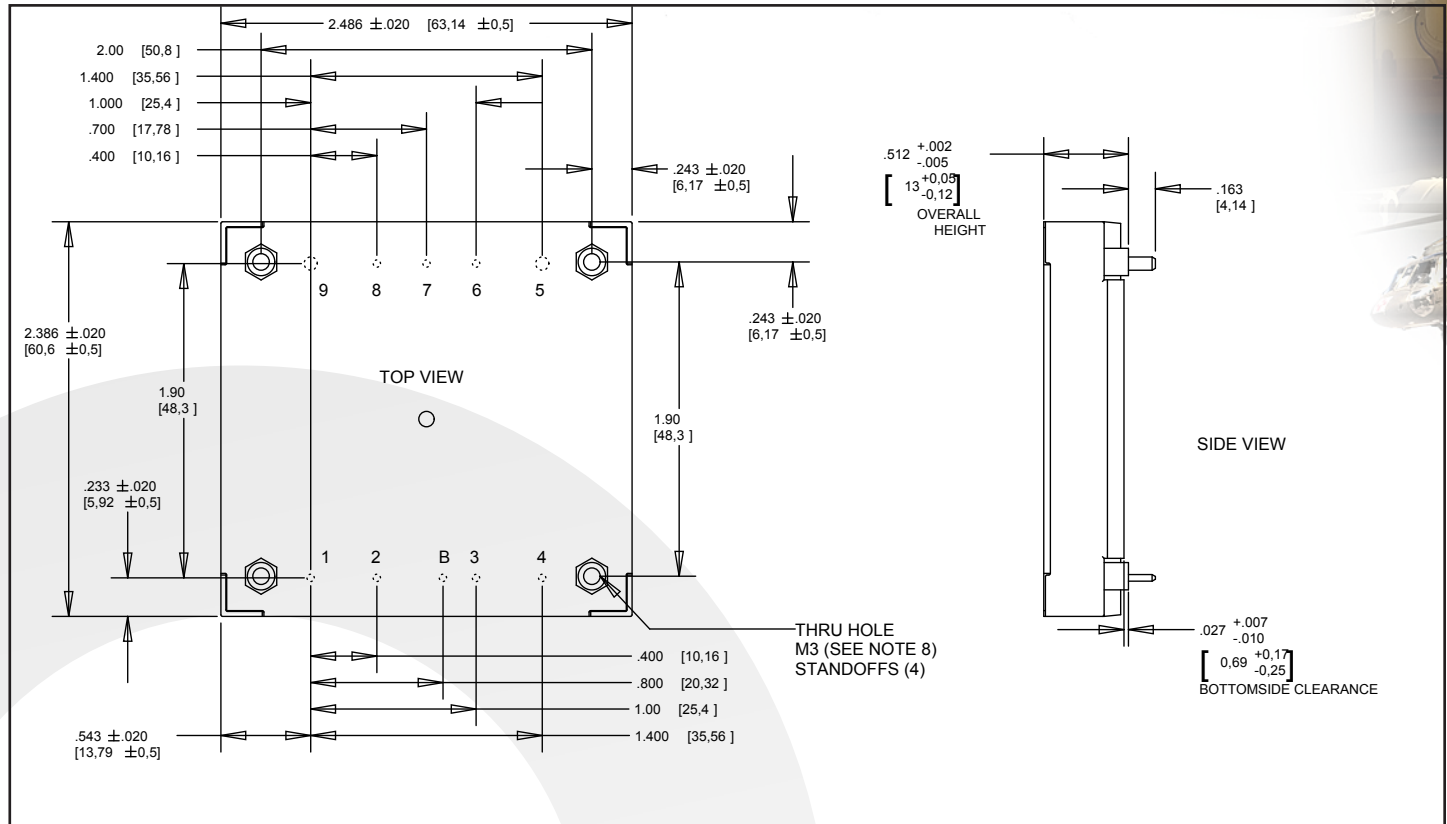

### NOTES

- Applied torque per screw should not exceed 6in-lb (0.7 Nm).
- Baseplate flatness tolerance is 0.004" (.10mm) TIR for surface.
- Pins 1-4, 6-8, and B are 0.040" (1.02mm) diameter, with 0.080" diameter standoff shoulders.
- Pins 5 and 9 are 0.080" (2.03 mm) diameter with 0.125" (3.18 mm) diameter standoff shoulders.
- All Pins: Material – Copper Alloy; Finish – Matte Tin over Nickel plate
- Undimensioned components are shown for visual reference only.
- Weight: 4.9 oz. (139 g) typical
- Threaded or Non-Threaded options available
- All dimensions in inches (mm)  
Tolerances: x.xx +/-0.02 in. (x.x +/-0.5mm)  
x.xxx +/-0.010 in. (x.xx +/-0.25mm)
- Workmanship: Meets or exceeds IPC-A610 Class II
- Recommended pin length is 0.03" (0.76mm) greater than the PCB thickness.

### PIN DESIGNATIONS

Pin	Name	Function
1	Vin(+)	Positive input voltage
2	ON/OFF	TTL input to turn converter on and off, referenced to Vin(-), with internal pull up.
B	SHARE(+)	Active current share differential pair (see Full-Feature Application Notes) (Note 4)
3	SHARE(-)	
4	IN RTN	Input Return
5	OUT RTN	Output Return
6	SENSE(-)	Negative remote sense <sup>1</sup>
7	TRIM	Output voltage trim <sup>2</sup>
8	SENSE(+)	Positive remote sense <sup>3</sup>
9	Vout(+)	Positive output voltage

#### Notes:

- SENSE(-) should be connected to Vout(-) either remotely or at the converter.
- Leave TRIM pin open for nominal output voltage.
- SENSE(+) should be connected to Vout(+) either remotely or at the converter.
- On standard product, Pin B & Pin 3 are absent

### Mechanical Drawing – Flanged Heatsink Option

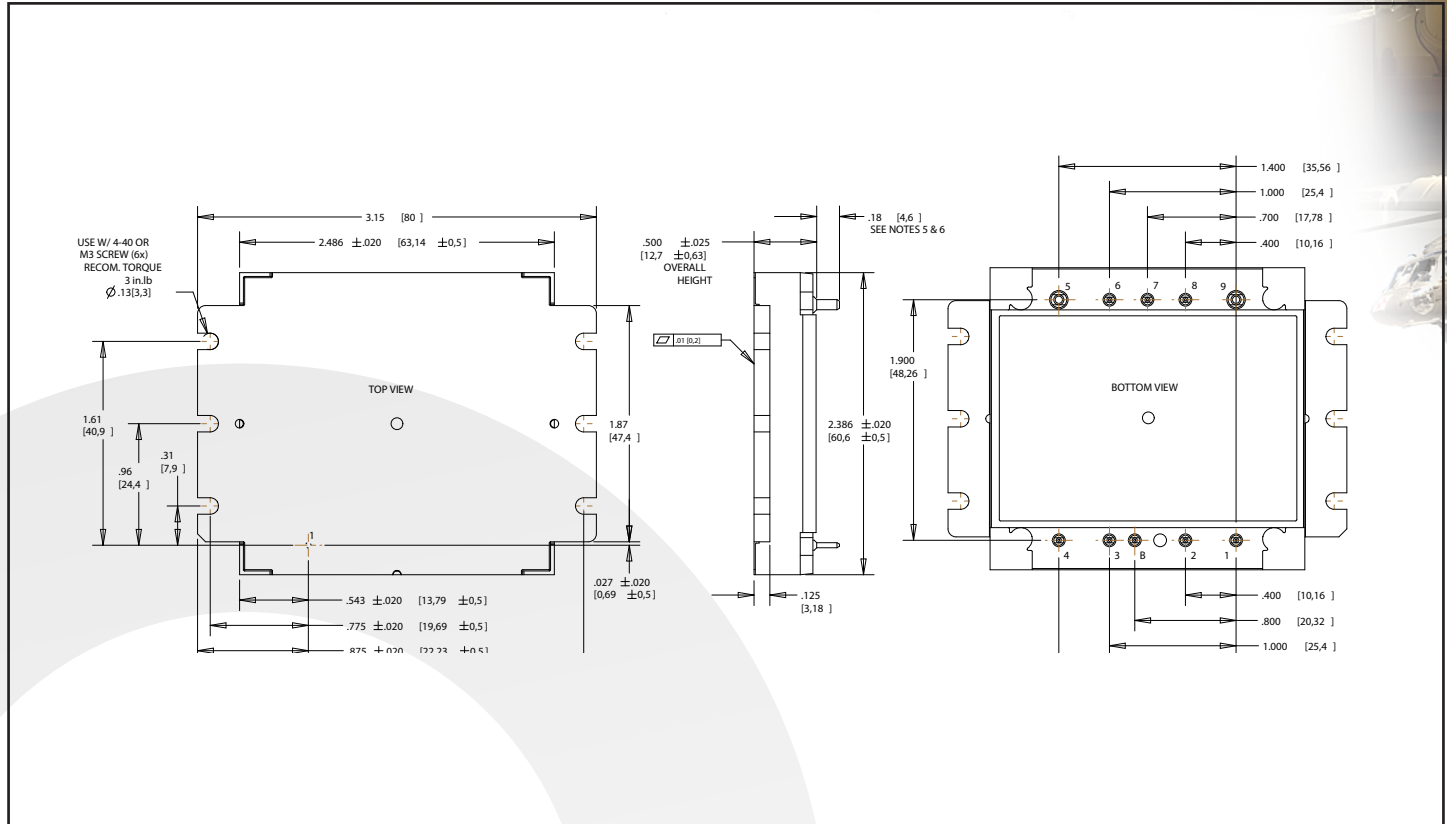

### NOTES

- Applied torque per screw should not exceed 5in-lb (3in-lb recommended).
- Baseplate flatness tolerance is 0.01" (.25mm) TIR for surface.
- Pins 1-4, 6-8, and B are 0.040" (1.02mm) diameter, with 0.080" diameter standoff shoulders.
- Pins 5 and 9 are 0.080" (2.03 mm) diameter with 0.125" (3.18 mm) diameter standoff shoulders.
- All Pins: Material – Copper Alloy; Finish – Matte Tin over Nickel plate
- Weight: 4.8 oz. (137 g) typical
- Undimensioned components are shown for visual reference only.
- All dimensions in inches (mm)  
Tolerances: x.xx +/-0.02 in. (x.x +/-0.5mm)  
x.xxx +/-0.010 in. (x.xx +/-0.25mm)
- Workmanship: Meets or exceeds IPC-A610 Class II
- Recommended pin length is 0.03" (0.76mm) greater than the PCB thickness.
- A thermal interface material is required to assure proper heat transfer from the flanged baseplate to the cooling surface. Thermal grease, conductive pads, compounds, and other similar products are available from many heatsink manufacturers.

### PIN DESIGNATIONS

Pin	Name	Function
1	Vin(+)	Positive input voltage
2	ON/OFF	TTL input to turn converter on and off, referenced to Vin(-), with internal pull up.
B	SHARE(+)	Active current share differential pair (see Full-Feature Application Notes) (Note 4)
3	SHARE(-)	
4	IN RTN	Input Return
5	OUT RTN	Output Return
6	SENSE(-)	Negative remote sense <sup>1</sup>
7	TRIM	Output voltage trim <sup>2</sup>
8	SENSE(+)	Positive remote sense <sup>3</sup>
9	Vout(+)	Positive output voltage

#### Notes:

- SENSE(-) should be connected to Vout(-) either remotely or at the converter.
- Leave TRIM pin open for nominal output voltage.
- SENSE(+) should be connected to Vout(+) either remotely or at the converter.
- On standard product, Pin B & Pin 3 are absent



**Mil-COTS Qualification**

Test Name	Details	# Tested (# Failed)	Consistent with MIL-STD-883F Method	Consistent with MIL-STD-883F Method 5005
Life Testing	Visual, mechanical and electrical testing before, during and after 1000 hour burn-in @ full load	15 (0)	Method 1005.8	
Shock-Vibration	Visual, mechanical and electrical testing before, during and after shock and vibration tests	5 (0)		MIL-STD-202, Methods 201A & 213A
Humidity	+85°C, 85% RH, 1000 hours, 2 minutes on/6 hours off	8 (0)	Method 1004.7	
Temperature Cycling	500 cycles of -55°C to +100°C (30 minute dwell at each temperature)	10 (0)	Method 1010.8	Condition A
Solderability	15 pins	15 (0)	Method 2003	
DMT	-65°C to +110°C across full line and load specifications in 5°C steps	7 (0)		
Altitude	70,000 feet (21 km), see Note	2 (0)		

Note: A conductive cooling design is generally needed for high altitude applications because of naturally poor convective cooling at rare atmospheres.

**Mil-COTS Screening**

Screening	Process Description	S-Grade	M-Grade
Baseplate Operating Temperature		-55°C to +100°C	-55°C to +100°C
Storage Temperature		-65°C to +135°C	-65°C to +135°C
Pre-Cap Inspection	IPC-610, Class III	•	•
Temperature Cycling	Method 1010, Condition B, 10 Cycles		•
Burn-In	100°C Baseplate	12 Hours	96 Hours
Final Electrical Test	100%	25°C	-55°C, +25°C, +100°C
Final Visual Inspection	MIL-STD-2008	•	•

## Ordering Information/ Part Numbering

Example MCOTS-C-28-50-HZ-N-S

Not all combinations make valid part numbers, please contact SynQor for availability. See [product summary page](#) for details.

Family	Product	Input Voltage	Output Voltage	Package	Heatsink Option	Screening Level	Options
MCOTS	C: Converter	<b>28:</b> 16-40V <b>28V:</b> 9-40V <b>28VE:</b> 9-70V <b>48:</b> 34-75V	<b>05:</b> 5V <b>12:</b> 12V <b>15:</b> 15V <b>24:</b> 24V <b>28:</b> 28V <b>40:</b> 40V <b>50:</b> 50V	HZ:Half Brick Zeta	<b>N:</b> Normal Threaded <b>D:</b> Normal Non-Threaded <b>F:</b> Flanged	<b>S:</b> S-Grade <b>M:</b> M-Grade	<b>F:</b> Full Feature

## APPLICATION NOTES

A variety of application notes and technical white papers can be downloaded in pdf format from our [website](#).

## PATENTS

SynQor holds the following U.S. patents, one or more of which apply to each product listed in this document. Additional patent applications may be pending or filed in the future.

5,999,417	6,222,742	6,545,890	6,577,109	6,594,159
6,731,520	6,894,468	6,896,526	6,927,987	7,050,309
7,072,190	7,085,146	7,119,524	7,269,034	7,272,021
7,272,023	7,558,083	7,564,702		

## Contact SynQor for further information:

**Phone:** 978-849-0600  
**Toll Free:** 888-567-9596  
**Fax:** 978-849-0602  
**E-mail:** [mqnbfae@synqor.com](mailto:mqnbfae@synqor.com)  
**Web:** [www.synqor.com](http://www.synqor.com)  
**Address:** 155 Swanson Road  
 Boxborough, MA 01719  
 USA

### Warranty

SynQor offers a two (2) year limited warranty. Complete warranty information is listed on our website or is available upon request from SynQor.

Information furnished by SynQor is believed to be accurate and reliable. However, no responsibility is assumed by SynQor for its use, nor for any infringements of patents or other rights of third parties which may result from its use. No license is granted by implication or otherwise under any patent or patent rights of SynQor.