

FEATURES

- MOLDED CONSTRUCTION FOR HIGH SOLDERING HEAT RESISTANCE
- NINE CASE SIZES WITH MANY NEW EXTENDED RANGE RATINGS
- BOTH FLOW AND REFLOW SOLDERING APPLICABLE
- TAPE AND REEL PACKAGING COMPATIBLE WITH AUTOMATIC PICK AND PLACE EQUIPMENT

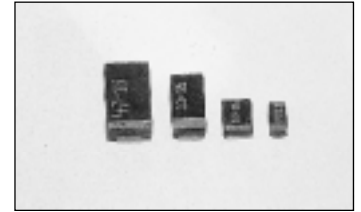

SPECIFICATIONS AND PERFORMANCE CHARACTERISTICS

Capacitance Range	0.1µF to 470µF								
Capacitance Tolerance	±20%(M), ±10%(K)								
Rated Voltage Range @ 85°C (Vdc)	2.5	4.0	6.3	10	16	20	25	35	50
Surge Voltage Rating @ 85°C (Vdc)	3.3	5.2	8.0	13	20	26	33	46	65
Derated Voltage @ 125°C (Vdc)	1.6	2.5	4.0	6.3	10	13	16	22	32
Operating Temperature Range	-55°C to +85°C (to +125°C With Derating)								
Dissipation Factor	See Case Size and Specifications Table								
Leakage Current @ +25°C (After 5 Minutes at Rated Voltage)	Not More Than 0.01 CV or 0.5µA, whichever is greater								
Capacitance Change With Temperature	-55°C			+85°C			+125°C		
A2, A, B2, B, C, D & E Case Size	ΔC -12%			ΔC ±12%			ΔC ±15%		
J & P Case Size	ΔC -20%			ΔC ±20%			ΔC ±20%		
Soldering Heat Resistance (+260°C for 5 Seconds)	ΔC ±5%* Max., LC = Less than initial specification. DF = Less than initial specification.								
Moisture Resistance (500 hours; 90~95% RH @ 40°C)	ΔC ±5%* Max., LC = Less than initial specification. DF = 150% of initial specification								
Temperature Cycling (5 cycles; -55°C ~ +125°C)	ΔC ±5%* Max, LC = Less than initial specification. DF = Less than initial specification								
Load Life (At Rated Voltage) (2000 hours @ +85°C)	ΔC ±10%* Max, LC = 125% of initial specification. DF = Less than initial specification								
Base Failure Rate (1.0Ω/Volt)	1%/1000 hours at 60% confidence level. (+85°C)								

*±12% ~ ±15% for extended values, ±20% for J & P case size values

RIPPLE CURRENT CORRECTION FACTOR:

Ambient Temperature	+25°C	+55°C	+85°C	+105°C	+125°C
Correction Factor	1.0	0.90	0.80	0.40	0.15

POWER DISSIPATION @ 25°C (FREE AIR) & EQUIVALENT SERIES INDUCTANCE (ESL)

Case Code	Pd MAX. (W)	ESL (nH)
P	0.025	1.00
A2	0.050	1.20
A	0.070	1.20
B2	0.070	1.50
B	0.080	1.50
C	0.110	2.70
D	0.150	3.00
E	0.165	3.00

RIPPLE CURRENT/VOLTAGE RATINGS:

$$I_{max.} = \sqrt{\frac{Pd}{ESR}} \quad V_{max.} = Z \cdot \sqrt{\frac{Pd}{ESR}}$$

I_{max.} = Ripple Current rating (Arms)

Pd = Power dissipation (watt)

ESR = Equivalent series resistance (ohm)

V_{max.} = Ripple voltage rating (Vrms)

Z = The capacitors impedance (ohm) = $\sqrt{(ESR)^2 + (XL-XC)^2}$

PART NUMBERING SYSTEM

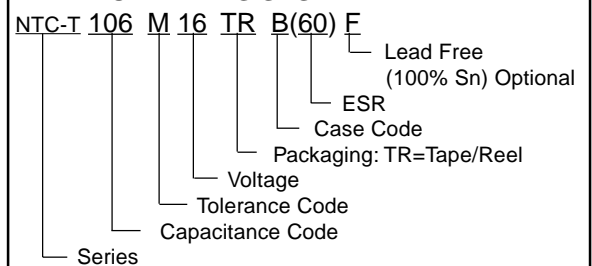

STANDARD AND EXTENDED PRODUCT SPECIFICATIONS TABLE

* Extended Case Sizes

Chart shows Case Size, Max Tan δ @ 120Hz/+20°C, Max. ESR @ 100KHz/+20°C

Cap. (μF)	Code	Working Voltage (Vdc)								
		2.5	4.0	6.3	10	16	20	25	35	50
0.1	104						A2*6%/40Ω		A 4%/18Ω	A 4%/20Ω
0.15	154						A2*6%/325Ω		A 4%/18Ω	A 4%/19Ω
0.22	224						A2*6%/35Ω		A 4%/18Ω	B 4%/14Ω
0.33	334					P 10%/40Ω	A2*6%/30Ω		A 4%/15Ω	B 4%/10Ω
0.47	474					P 10%/35Ω	A2*6%/27Ω	A 4%/14Ω	A*6%/12Ω B 4%/8.0Ω	B 4%/9.0Ω
0.68	684				P 10%/25Ω	P 10%/25Ω A2*6%/25Ω	A2*6%/15Ω A 4%/12Ω	A*6%/10Ω	A*6%/9.0Ω B 4%/5.4Ω	C 4%/7.0Ω
1.0	105			P 10%/25Ω	P 10%/25Ω A2*8%/25Ω	J 10%/30Ω P 20%/25Ω A2*6%/16Ω A 4%/10Ω	A2*6%/13Ω A*6%/9.0Ω	A*6%/8.0Ω	A*6%/8.0Ω B 4%/4.8Ω	C 4%/5.5Ω
1.5	155		P 10%/25Ω	P 10%/25Ω A2*8%/25Ω	J 20%/30Ω P 20%/25Ω A2*8%/20Ω A 4%/8.0Ω	A2*6%/13Ω A 4%/8.0Ω	A2*6%/13Ω A*6%/6.5Ω	A*6%/8.0Ω B 4%/4.6Ω	A*6%/8.0Ω B*6%/4.0Ω C 4%/3.0Ω	C 4%/4.0Ω
2.2	225	P 10%/25Ω	P 10%/25Ω A2*8%/25Ω	J 20%/20Ω P 20%/20Ω A2*8%/18Ω A 4%/8.0Ω	J 20%/30Ω P 20%/20Ω A2*8%/12Ω A 4%/7.0Ω	A2*6%/13Ω A*6%/6.0Ω	A*6%/6.0Ω B 4%/3.5Ω	A*6%/8.0Ω B*6%/4.0Ω	B*6%/4.2Ω C 4%/3.0Ω	D 4%/1.8Ω
3.3	335	P 10%/25Ω	P 20%/20Ω A2*8%/18Ω A 4%/8.0Ω	J 20%/20Ω P 20%/20Ω A2*8%/9.0Ω A 4%/7.5Ω	P 20%/20Ω A2*8%/12Ω A*8%/5.5Ω	A*6%/5.0Ω B 4%/3.5Ω	A*6%/5.0Ω B*6%/3.0Ω	B*6%/3.5Ω C 4%/2.5Ω	B*6%/4.0Ω C 4%/2.5Ω D 4%/2.0Ω	D 4%/1.4Ω
4.7	475	P 20%/20Ω A2*8%/18Ω	P 20%/12Ω A2*8%/10Ω A 4%/7.5Ω	J 20%/15Ω P 20%/12Ω A2*8%/7.5Ω A*8%/6.0Ω	P 20%/10Ω A2*8%/8.0Ω A*8%/5.0Ω B 4%/3.5Ω	A*6%/5.0Ω B*6%/3.0Ω	A*6%/5.0Ω B*6%/3.0Ω C 4%/2.4Ω	B*6%/3.0Ω C 4%/2.4Ω	C*6%2.2Ω D 4%/1.5Ω	D 4%/1.4Ω
6.8	685	P 20%/20Ω A2*8%/16Ω	J 20%/15Ω P 20%/12Ω A2*8%/8.0Ω A*8%/6.0Ω	P 20%/12Ω A2*8%/7.5Ω A*8%/5.0Ω B 6%/3.5Ω	A*8%/4.5Ω B 8%/3.0Ω	A2*6%/5.0Ω A*6%/5.0Ω B2 6%/5.0Ω B*6%/2.5Ω C 6%/1.9Ω	B*6%/2.8Ω C 6%/1.9Ω	C*6%/1.9Ω D6%/1.4Ω	C*6%/1.9Ω D 6%/1.3Ω	
10	106	J 20%/12Ω P 20%/12Ω A2*8%/15Ω	J 20%/12Ω P 20%/12Ω A2*12%/8.0Ω A*8%/5.0Ω B 6%/3.5Ω	P 20%/12Ω A2*8%/10Ω A*8%/4.0Ω B 6%/3.0Ω	A2 8%/5.0Ω A*8%/3.2Ω B2*8%/3.2Ω B*8%/2.5Ω C 6%/1.8Ω	A 8%/5.0Ω B2 8%/4.0Ω B*6%/2.4Ω C 6%/1.8Ω	B*6%/2.5Ω C*6%/1.8Ω D 6%/1.3Ω	C*6%/1.8Ω D 6%/1.2Ω	D*6%/1.0Ω	
15	156	A2*12%/10Ω A*8%/5.0Ω	P 20%/ A2*12%/8.0Ω A*8%/4.0Ω B*8%/3.0Ω	A2 12%/ A*8%/3.5Ω B2*8%/3.5Ω B*8%/2.5Ω C 6%/1.8Ω	B2*8%/2.5Ω C 6%/1.8Ω	B2*6%/2.5Ω C*6%/1.8Ω D 6%/1.8Ω	C*6%/1.7Ω D 6%/0.8Ω	D*6%/1.0Ω	D*6%/0.9Ω	
22	226	A2*12%/10Ω A*8%/4.0Ω	P 20%/5.0Ω A2 12%/4.0Ω A*8%/3.5Ω B2*8%/3.5Ω B*8%/2.8Ω C 6%/1.8Ω	A*10%/4.5Ω B2 12%/4.5Ω B*8%/2.3Ω C 6%/1.8Ω	B2 12%/4.0Ω B*8%/2.4Ω C*8%/1.8Ω D 6%/1.5Ω	B*6%/2.5Ω C*6%/1.6Ω D 6%/0.8Ω	C*6%/1.5Ω D*6%/0.8Ω	D*6%/0.8Ω		

SURFACE MOUNT



STANDARD AND EXTENDED PRODUCT SPECIFICATION TABLE

* Extended Case Sizes

Chart shows Case Size, Max Tan δ @ 120Hz/+20°C, Max. ESR @ 100KHz/+20°C

SURFACE MOUNT

Cap. (μF)	Code	Working Voltage (Vdc)									
		2.5	4.0	6.3	10	16	20	25	35	50	
33	336	P 20%/5.0Ω A*8%/3.5Ω B2*8%/3.5Ω B*8%/3.0Ω	A*10%/4.5Ω B2*12%/4.5Ω B*8%/2.4Ω C 6%/1.8Ω	A 12%/5.0Ω B*8%/2.0Ω C*8%/1.8Ω D 6%/1.5Ω	B*8%/2.0Ω C*8%/1.6Ω D 6%/0.8Ω	C*6%/1.2Ω D*6%/0.8Ω					
47	476	A*12%/4.5Ω B2*12%/4.5Ω B*8%/2.4Ω	A 12%/5.0Ω B2 12%/3.0Ω B*8%/2.0Ω C*8%/1.8Ω D 6%/1.2Ω	B2 12%/3.0Ω B*8%/2.0Ω C*8%/1.6Ω D 6%/0.8Ω	B 8%/3.0Ω C*8%/1.6Ω D*8%/0.8Ω	C*6%/1.2Ω D*6%/0.8Ω					
68	686	A 18%/3.0Ω B*8%/2.0Ω	B2 15%/3.0Ω B*8%/2.0Ω C*8%/1.6Ω D 6%/0.8Ω	B*10%/1.8Ω C*8%/1.2Ω D*8%/0.8Ω	C*8%/1.2Ω D*8%/0.8Ω	D*6%/0.7Ω					
100	107	B2 18%/2.0Ω B*8%/2.0Ω	B*12%/2.0Ω C*8%/1.2Ω D*8%/0.8Ω	B 12%/1.2Ω C*10%/0.9Ω D*8%/0.8Ω	C 10%/1.2Ω D*8%/0.7Ω	D*10%/1.0Ω					
150	157	B*16%/5.0Ω	B 18%/2.0Ω C*10%/1.0 D*8%/0.7Ω	C 10%/1.2Ω D*8%/0.7Ω	D*10%/0.7Ω	D*6%/0.9					
220	227	B 18%/2.0Ω C*12%/1.0Ω	C 12%/1.2Ω D*8%/0.7Ω	C 14%/1.2Ω D*12%/0.8Ω	D 12%/1.0Ω E*8%/0.9Ω						
330	337	C 16%/1.2Ω	C 14%/1.2Ω D*14%/0.7Ω	D 14%/1.0Ω							
470	477	C 18%/1.2Ω D*14%/0.7Ω	D 16%/1.0Ω								

DIMENSIONS (mm)

Case Code	Metric Code	English Code	L	W	H	P	a
J	1608	0603	1.6 ± 0.1	0.8 ± 0.1	0.8 ± 0.1	0.3 ± 0.15	0.6 ± 0.1
P	2012	0805	2.0 ± 0.2	1.25 ± 0.2	1.2 MAX.	0.5 ± 0.2	0.9 ± 0.1
A	3216	1206	3.2 ± 0.2	1.6 ± 0.2	1.6 ± 0.2	0.8 ± 0.3	1.2 ± 0.1
A2	3216	1206	3.2 ± 0.2	1.6 ± 0.2	1.2 MAX.	0.8 ± 0.3	1.2 ± 0.1
B	3528	1411	3.5 ± 0.2	2.8 ± 0.2	1.9 ± 0.2	0.8 ± 0.3	2.2 ± 0.1
B2	3528	1411	3.5 ± 0.2	2.8 ± 0.2	1.2 MAX.	0.8 ± 0.3	2.3 ± 0.1
C	6032	2412	6.0 ± 0.3	3.2 ± 0.3	2.6 ± 0.3	1.3 ± 0.3	2.2 ± 0.1
D	7343	2916	7.3 ± 0.2	4.3 ± 0.2	2.9 ± 0.3	1.3 ± 0.3	2.4 ± 0.1
E	7343H	2917	7.3 ± 0.2	4.3 ± 0.2	4.1 ± 0.2	1.3 ± 0.3	2.4 ± 0.1

J, P, A, A2, C, D & E CASE SIZE

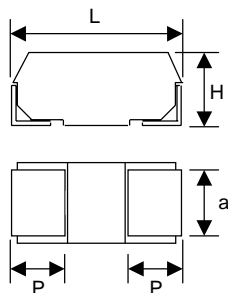

B & B2 CASE SIZE

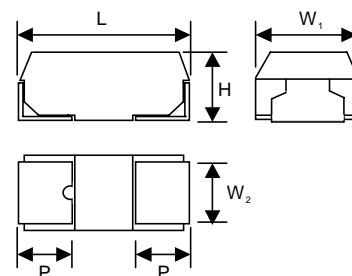

CAPACITANCE CODES

Cap. (μF)	STD EIA Code	EIA Code 198D	Code for P Case Size	Code for J Case Size		
				2.5Vdc	4Vdc	6.3Vdc
0.1	104	A5	-	-	-	-
0.15	154	E5	-	-	-	-
0.22	224	J5	-	-	-	-
0.33	334	N5	N	-	-	-
0.47	474	S5	S	-	-	-
0.68	684	W5	W	-	-	-
1.0	105	A6	A	-	-	-
1.5	155	E6	E	-	-	-
2.2	225	J6	J	-	-	∩
3.3	335	N6	N	-	-	↵
4.7	475	S6	S	-	⊙	J
6.8	685	W6	W	-	G	-
10	106	A7	a	e	⊙	-
22	226	J7	-	-	-	-

VOLTAGE CODES

Volts	Code
2.5	e
4	G
6.3	J
10	A
16	C
20	D
25	E
35	V
50	H

COMPONENT MARKING

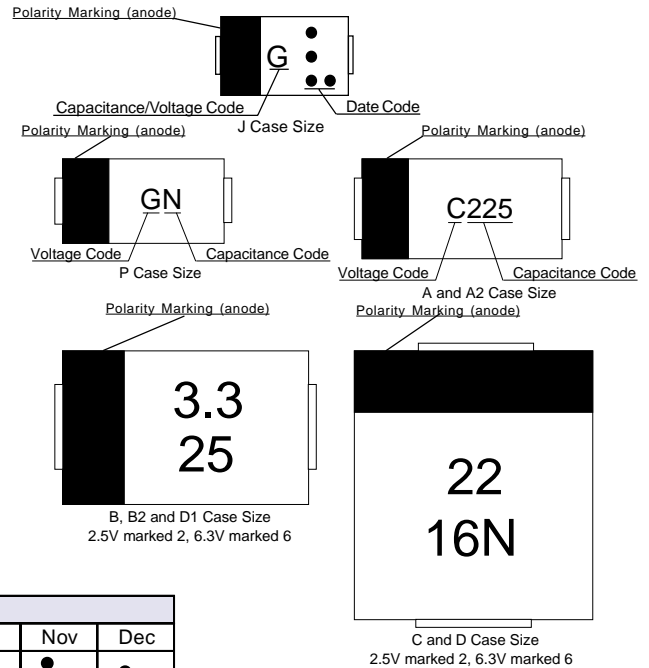

SURFACE MOUNT

PRODUCTION CODE

2000											
Jan	Feb	Mar	Apr	May	Jun	Jul	Aug	Sep	Oct	Nov	Dec
•	••	•	••	••	••	••	••	•	•	••	••
2001											
Jan	Feb	Mar	Apr	May	Jun	Jul	Aug	Sep	Oct	Nov	Dec
••	••	••	••	••	••	••	••	••	••	••	••

FLOW/REFLOW SOLDERING
 MAXIMUM TEMPERATURE/TIME: FLOW 260°C/5 Sec.
 REFLOW 260°C/10 Sec.

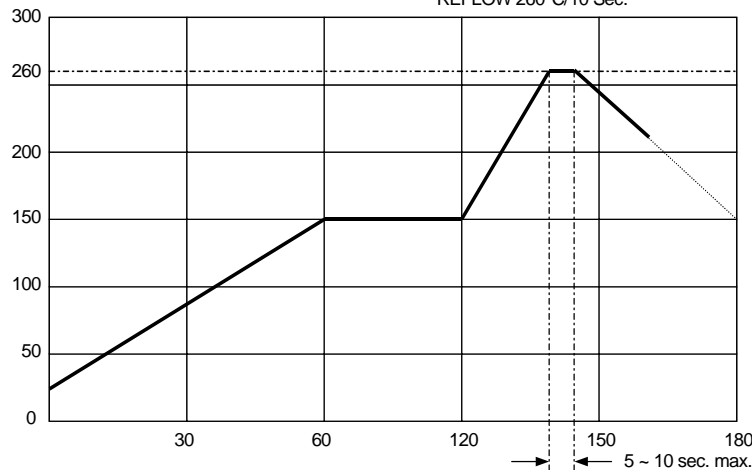

RECOMMENDED LAND PATTERN DIMENSIONS (mm)

Case Size	a	b	c
J	0.90	0.70	1.00
P	1.05	0.50	1.20
A & A2	1.35	1.10	1.50
B & B2	1.35	1.40	2.70
C	2.00	2.90	2.70
D1	2.00	2.70	2.90
D	2.05	4.10	2.90

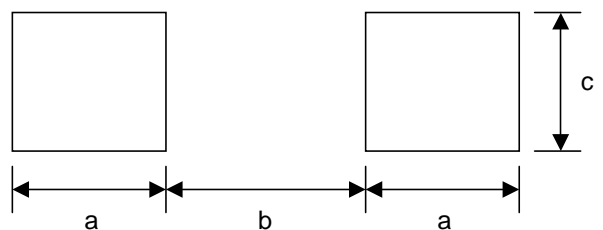

TAPE DIMENSIONS (mm)

Metric Code	Case Code	$A_0 \pm 0.2$	$B_0 \pm 0.2$	$W \pm .30$	$F \pm .05$	$P_0 \pm 0.1$	$P_1 \pm 0.1$	$P_2 \pm 0.05$	$G \pm 0.1$	$K \pm 0.2$	T	7" Reel
1608	J	1.0	1.8	8.0	3.5	4.0	4.0	2.0	1.75	1.1	0.2	4000
2012	P	1.4	2.2	8.0	3.5	4.0	4.0	2.0	1.75	1.4	0.2	3000
3216	A2	1.9	3.5	8.0	3.5	4.0	4.0	2.0	1.75	1.4	0.2	3000
3216	A	1.9	3.5	8.0	3.5	4.0	4.0	2.0	1.75	1.9	0.2	2000
3528	B2	3.2	3.8	8.0	3.5	4.0	4.0	2.0	1.75	1.4	0.2	3000
3528	B	3.2	3.8	8.0	3.5	4.0	4.0	2.0	1.75	2.1	0.2	2000
6032	C	3.7	6.4	12.0	5.65	4.0	8.0	2.0	1.5	3.0	0.3	500
7343	D	4.8	7.7	12.0	5.65	4.0	8.0	2.0	1.5	3.3	0.3	500
7343H	E	4.7	7.7	12.0	5.5	4.0	8.0	2.0	1.5	4.5	0.6	500

SURFACE MOUNT

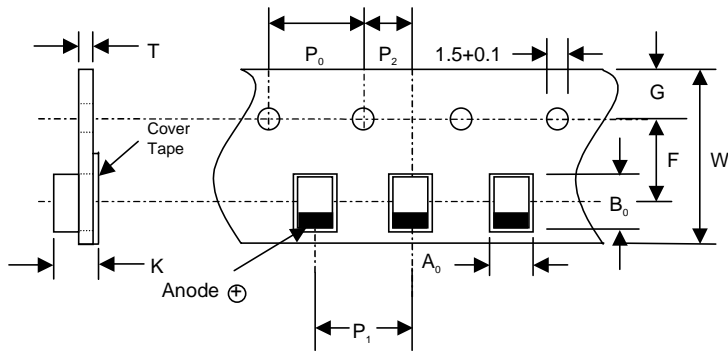

Cover tape peel-off specification

1. Peel-off speed : 300 mm/min.
2. Peel-off force : $F = 30 - 75g$
3. Peel-off angle : $\Theta = 0 - 15^\circ$

Peel-off speed
(F) = 50mm/Sec.

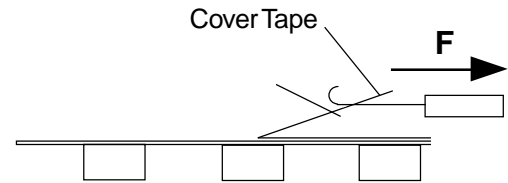

REEL DIMENSIONS (mm)

Tape Width	A	C	D	E	N	W1	W2
8mm	178 ± 2.0	13 ± 0.5	21 ± 0.5	2.0 ± 0.5	50 min.	10 ± 2.0	14.5 max
12mm	178 ± 2.0	13 ± 0.5	21 ± 0.5	2.0 ± 0.5	50 min.	14.5 ± 2.0	18.5 max

