

Precision Metal Film Resistors

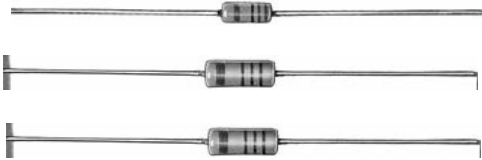

FEATURES

- 0.125 W to 0.5 W at 70 °C
- NFC 83-230/CECC 40 100
- ESA-SCC 4001
- LN2/GAM-T-1
- Wide ohmic range from 1 Ω to 5.7 MΩ
- Good initial precision up to ± 0.1 %
- Operating temperatures:
 - 55 °C to + 155 °C
 - 25 °C to + 85 °C for TCR ≤ ± 15 ppm/°C
- Protection: "SPINSEAL®" epoxy
- Termination: Pure Matt Tin



RoHS
COMPLIANT

DIMENSIONS in millimeters

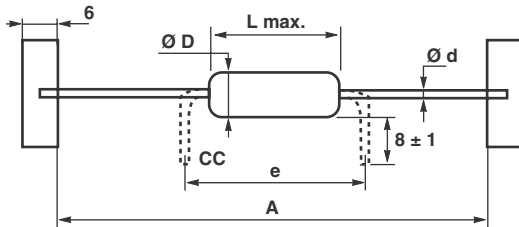

TYPE	Ø D max.	L max.	A ± 1	Ø d	CC _e	MAX. UNIT WEIGHT
N.. 3..	1.8	3.9	53	0.5	5.08	0.15 g
N.. 4..	2.5	6.2	53	0.6	NA	0.3 g
N.. 5..	3.3	8.7	53	0.6	NA	0.5 g

TECHNICAL SPECIFICATIONS

MODEL	NT3S	NP3S	NY3	NK3	NT4S	NP4S	NY4	NK4	NT5S	NP5S	NY5	NK5	
Power Rating at + 70 °C	0.125 W	0.25 W			0.25 W	0.5 W			0.5 W				
Ohmic Value Range in Relation to: Temperature Coefficient of Resistance, Tolerance	± 0.1 %	100 Ω E 192	-	-	49.9 Ω E 96	E 192	-	-	100 Ω E 96	E 192	-	-	
	± 15 ppm/°C	± 0.25 % 200 kΩ	-	-	499 kΩ	-	-	-	499 kΩ	-	-	-	
	± 0.5 %	10 Ω E 96	-	E 192	-	10 Ω E 96	E 192	-	10 Ω E 96	E 192	-	-	
	± 1 %	200 kΩ	-	-	499 kΩ	-	-	-	499 kΩ	-	-	-	
	± 25 ppm/°C	± 0.1 %	-	100 Ω E 192	-	-	10 Ω	-	-	-	100 Ω	-	-
		± 0.25 %	-	511 kΩ	-	-	1 MΩ	-	-	-	1 MΩ	-	-
		± 0.5 %	-	10 Ω E 96	-	E 192	-	-	-	-	10 Ω E 96	-	E 192
	± 50 ppm/°C	± 0.1 %	-	-	-	-	-	10 Ω E 192	-	-	-	10 Ω E 192	-
		± 0.25 %	-	-	-	-	-	1 MΩ	-	-	-	1 MΩ	-
		± 0.5 %	-	-	10 Ω E 192	-	-	10 Ω E 192	-	-	-	10 Ω E 192	-
	± 100 ppm/°C	± 1 %	-	-	1 Ω E 96	-	-	1 Ω E 96	-	-	-	3.01 Ω E 96	-
		± 2 %	-	-	1.5 MΩ	-	-	4.7 MΩ	-	-	-	4.7 MΩ	-
± 5 %	-	-	-	1 Ω E 24	-	-	-	1 Ω E 24	-	-	-	2.7 Ω E 24	
± 5 %	-	-	-	1.5 MΩ	-	-	4.7 MΩ	-	-	-	-	4.7 MΩ	
Limiting Element Voltage VRMS	200 V				350 V				350 V				
Critical Resistance	-	-	160 kΩ	490 kΩ	245 kΩ			245 kΩ					
Thermal Resistance	170 °C/W				145 °C/W				110 °C/W				



OFFICIAL APPROVAL AND PREFERENTIAL LISTS										
SERIES AND MODEL	SPECIFICATION	DESIGNATION	CECC REFERENCE	QUALIFIED RANGE	TOL ± %	PN AT + 70 °C W	PREFERENTIAL LISTS			
							BT	CCQ	CNET	GAM
NY3	40 101-002	RS 59Y	EY	10 Ω 301 kΩ	1	0.125		•	•	
	002	RS 48Y	AY			0.063		•	•	•
	803	AC	-			0.063		•		
NK3	40 101-001	RC 9	DU	10 Ω 510 kΩ	2 - 5	0.250		•		
	001	RC 8U	AU			0.125		•	•	•
	802	AV	-	10 Ω 150 kΩ	2 - 5	0.125		•		
NP4S	002	RS 64P	FP	100 Ω 1 MΩ	0.5 - 1	0.250		•	•	
	002	RS 58P	BP			0.125		•	•	
NY4	40 101-002	RS 71Y	GY	10 Ω 1 MΩ	0.5 - 1	0.500		•		
	002	RS 64Y	FY			0.250		•	•	•
	002	RS 58Y	BY			0.125		•	•	•
	803	BC	-			0.125		•		
NK4	40 101-001	RC 32	EU	10 Ω 1 MΩ	2 - 5	0.5		•	•	•
	001	RC 21U	BU			0.25		•	•	•
	802	BV	-			0.25		•		
NY5	40 101-002	RS 69Y	HY	10 Ω 1 MΩ	0.5 - 1	0.5		•		
	002	RS 63Y	CY			0.25		•	•	•
	803	CC	-			0.25		•		
NK5	40 101-001	RC 31U	CU	10 Ω 1 MΩ	2 - 5	0.5		•	•	•
	802	CV	-					•		

PERFORMANCE		
TEST	CONDITIONS	TYPICAL VALUES AND DRIFTS
Load Life at maximum Category Temperature	1000 h at 155 °C IEC 115-1 4.25.3	≤ ± 0.2 %
Short Time Overload	2.5 Pn or 2 Un 2 s for N..3.. 5 s for > N3 IEC 115-1 4.13	≤ ± 0.02 %
Damp Heat Humidity (Steady State)	56 days with low load IEC 115-1 IEC 68-2-3	≤ ± 0.2 %
Rapid Temperature Change	IEC 115-1 4.16 IEC 68-2.14	≤ ± 0.04 %
Climatic Sequence	dry heat damp heat cycle cold low pressure IEC 115-1 4.23	≤ ± 0.1 %
Terminal Strength	pull - twist - 2 bands	≤ ± 0.01 %
Vibration	10 - 500 Hz 10 g	≤ ± 0.01 %
Soldering (Thermal Shock)	+ 260 °C 10 s	≤ ± 0.05 %
Load Life	1000 h at 70 °C cycle 90°/30° IEC 115-1 4.25.1	≤ ± 0.15 %
Shelf Life	1 year ambient temperature	≤ ± 0.1 %

POWER RATING CHARTS

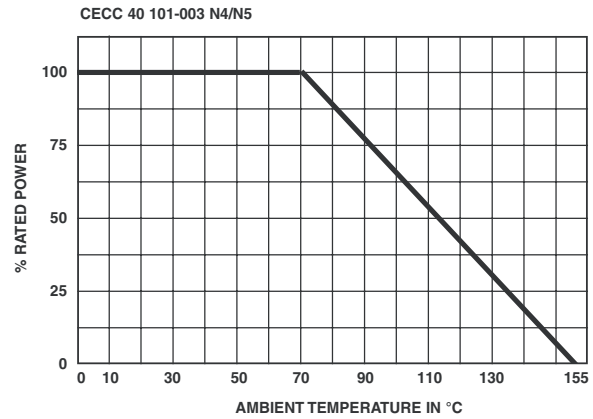
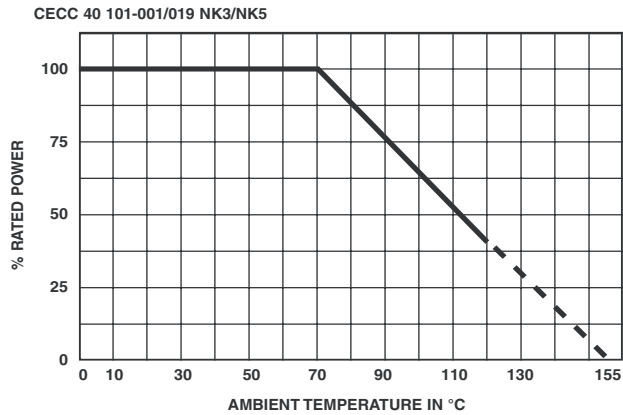

HIGH FREQUENCY

Typical behavior for NK4

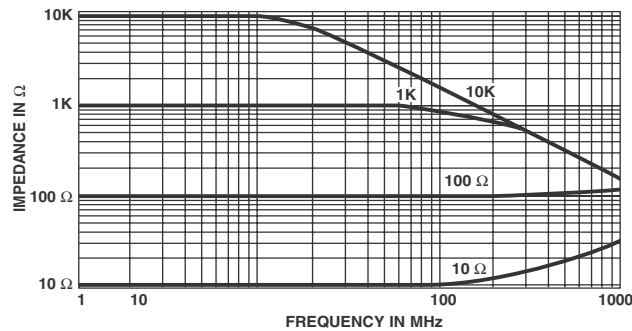

MARKING

Resistor color code chart 6, 5 or 4 bands.

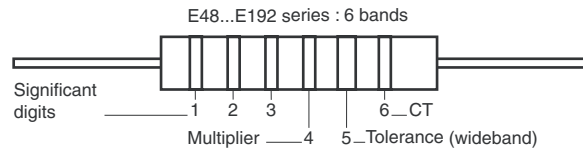

THIRD HARMONIQUE

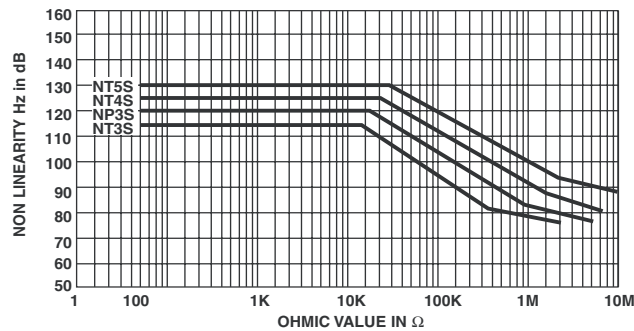

NOISE

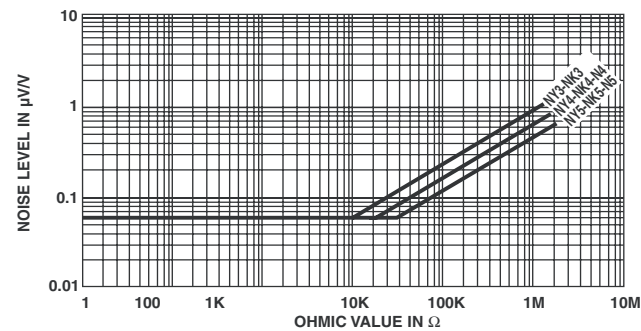

COLOR	DIGIT.	MULTIP.	TOL %	CT ppm/°C
Black	0	1		
Brown	1	10	1	
Red	2	10 ²	2	
Orange	3	10 ³		± 15
Yellow	4	10 ⁴		± 25
Green	5	10 ⁵	0.5	
Blue	6	10 ⁶	0.25	± 10
Purple	7	10 ⁷	0.1	± 5
Grey	8	10 ⁸		
White	9	10 ⁹		
Silver		10 ⁻²		
Gold		10 ⁻¹	5	



TAPE AND REEL	
SERIES AND MODEL	QUANTITY PER REEL
NT4S/NP4S	5000
NK4/N4/NY4	5000
SL3	5000
SL4	5000

TAPED IN AMMOPACK		
SERIES AND MODEL	QUANTITY PER BOX	BOX DIMENSIONS L x I x H mm ³
NT3S/NP3S	500	260 x 80 x 26
NY3	500	
NK3	1000	
NT4S/NP4S	500	
NY4	500	
NK4	1000	260 x 80 x 37
NK4	1000	340 x 85 x 90
NT5S/NP5S	500	260 x 85 x 28
NK5	500	

TAPED IN BAG		
SERIES AND MODEL	QUANTITY PER BAG	BAG DIMENSIONS mm ²
NP3S/NT3S	100	85 x 140
NP4S/NT4S		
NP5S/NT5S		
NY/NT CC	500	

PACKAGING

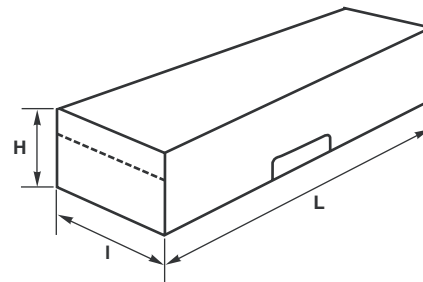
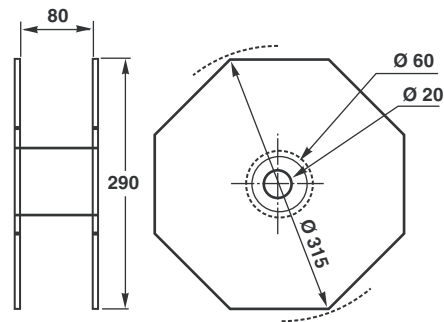
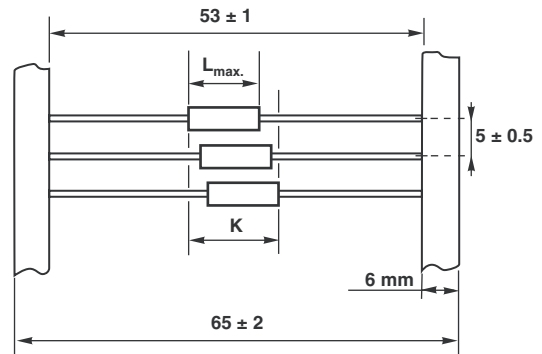

The resistors are required to be inside a window which is the K dimension. K being equal to the maximum body length of the resistor + 1.4 mm and being centered as per CEI 286 EIA 296D specification to the tape edges.

ORDERING INFORMATION					
T3	XXX	100 kΩ	1 %	AM1000	e3
MODEL	CUSTOM DESIGN	OHMIC VALUE	TOLERANCE	PACKAGING	LEAD (Pb)-FREE

SAP PART NUMBERING GUIDELINES			
NY3	10002	F	A22
MODEL	OHMIC VALUE	TOLERANCE	PACKAGING



Disclaimer

All product specifications and data are subject to change without notice.

Vishay Intertechnology, Inc., its affiliates, agents, and employees, and all persons acting on its or their behalf (collectively, "Vishay"), disclaim any and all liability for any errors, inaccuracies or incompleteness contained herein or in any other disclosure relating to any product.

Vishay disclaims any and all liability arising out of the use or application of any product described herein or of any information provided herein to the maximum extent permitted by law. The product specifications do not expand or otherwise modify Vishay's terms and conditions of purchase, including but not limited to the warranty expressed therein, which apply to these products.

No license, express or implied, by estoppel or otherwise, to any intellectual property rights is granted by this document or by any conduct of Vishay.

The products shown herein are not designed for use in medical, life-saving, or life-sustaining applications unless otherwise expressly indicated. Customers using or selling Vishay products not expressly indicated for use in such applications do so entirely at their own risk and agree to fully indemnify Vishay for any damages arising or resulting from such use or sale. Please contact authorized Vishay personnel to obtain written terms and conditions regarding products designed for such applications.

Product names and markings noted herein may be trademarks of their respective owners.