

isc Silicon NPN Power Transistor

2SD1437

DESCRIPTION

- Collector-Emitter Breakdown Voltage
: $V_{(BR)CEO} = 60V(\text{Min})$
- Complement to Type 2SB1033
- Low Collector Saturation Voltage

APPLICATIONS

- Designed for low frequency power amplification.

ABSOLUTE MAXIMUM RATINGS($T_a=25^\circ\text{C}$)

SYMBOL	PARAMETER	VALUE	UNIT
V_{CBO}	Collector-Base Voltage	80	V
V_{CEO}	Collector-Emitter Voltage	60	V
V_{EBO}	Emitter-Base Voltage	5	V
I_C	Collector Current-Continuous	3	A
P_C	Total Power Dissipation @ $T_C=25^\circ\text{C}$	40	W
T_J	Junction Temperature	150	$^\circ\text{C}$
T_{stg}	Storage Temperature Range	-55~150	$^\circ\text{C}$

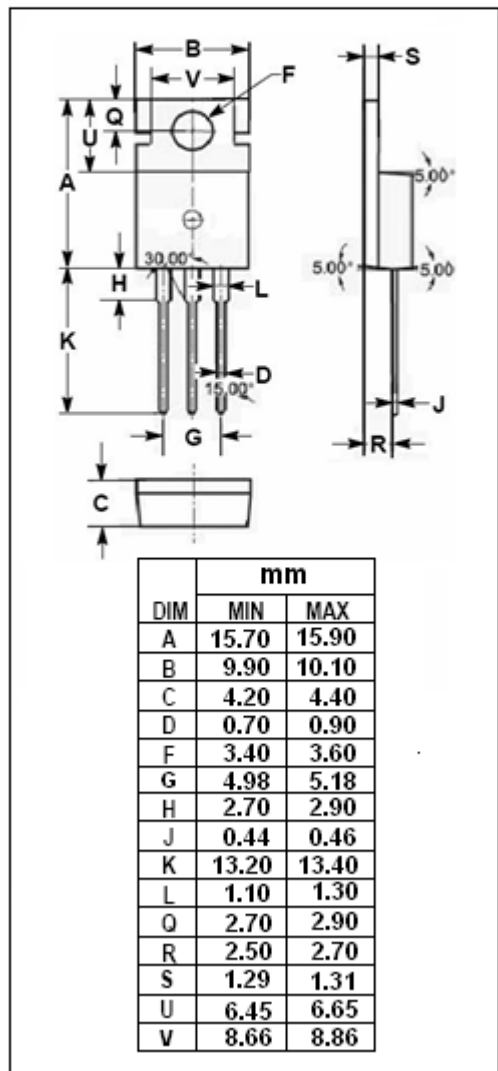
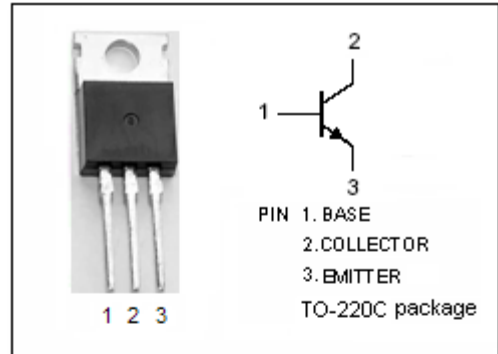

isc Silicon NPN Power Transistor

2SD1437

ELECTRICAL CHARACTERISTICS

 $T_C=25^{\circ}\text{C}$ unless otherwise specified

SYMBOL	PARAMETER	CONDITIONS	MIN	TYP.	MAX	UNIT
$V_{(BR)CEO}$	Collector-Emitter Breakdown Voltage	$I_C=10\text{mA}; I_B=0$	60			V
$V_{(BR)CBO}$	Collector-Base Breakdown Voltage	$I_C=0.1\text{mA}; I_E=0$	80			V
$V_{(BR)EBO}$	Emitter-Base Breakdown Voltage	$I_E=0.1\text{mA}; I_C=0$	5			V
$V_{CE(sat)}$	Collector-Emitter Saturation Voltage	$I_C=2\text{A}; I_B=0.2\text{A}$			1.0	V
$V_{BE(sat)}$	Base-Emitter Saturation Voltage	$I_C=2\text{A}; I_B=0.2\text{A}$			1.5	V
I_{CBO}	Collector Cutoff Current	$V_{CB}=60\text{V}; I_E=0$			10	μA
I_{EBO}	Emitter Cutoff Current	$V_{EB}=5\text{V}; I_C=0$			10	μA
h_{FE}	DC Current Gain	$I_C=1\text{A}; V_{CE}=5\text{V}$	60		320	
f_T	Current-Gain—Bandwidth Product	$I_C=0.5\text{A}; V_{CE}=5\text{V}$		8		MHz
C_{OB}	Output Capacitance	$I_E=0; V_{CB}=10\text{V}; f_{\text{test}}=1\text{MHz}$		90		pF

◆ h_{FE} Classifications

D	E	F
60-120	100-200	160-320