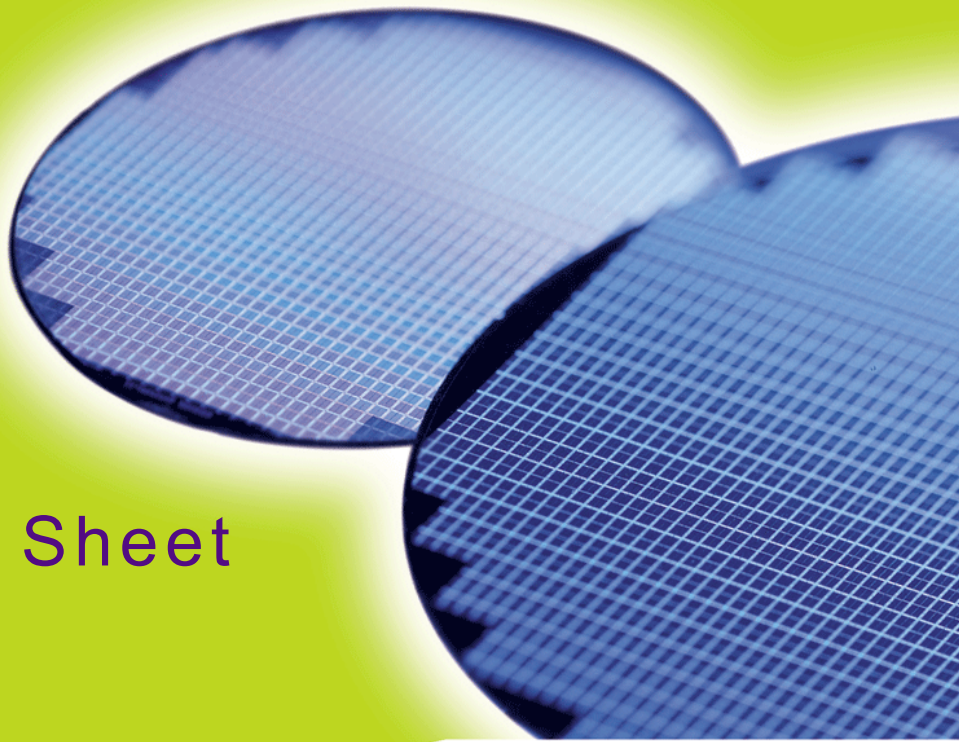


**HYB18H1G321A2F-08**  
**HYB18H1G321A2F-10**  
**HYB18H1G321A2F-14**

*GDDR3 Graphics RAM*  
*1-Gbit GDDR3 Graphics RAM*  
*EU RoHS compliant*

*Advance*  
**Internet Data Sheet**

*Rev. 0.61*





HYB18H1G321A2F-08, HYB18H1G321A2F-10, HYB18H1G321A2F-14

**Revision History: 2008-10, Rev. 0.61**

Page	Subjects (major changes since last revision)
All	Adapted internet version

**We Listen to Your Comments**

Any information within this document that you feel is wrong, unclear or missing at all?

Your feedback will help us to continuously improve the quality of this document.

Please send your proposal (including a reference to this document) to:

[techdoc@qimonda.com](mailto:techdoc@qimonda.com)



# 1 Overview

This chapter lists all main features of the product family HYB18H1G321A2F and the ordering information.

## 1.1 Features

- 1.8 V and 1.5 V  $V_{DDQ}$  IO voltage HYB18H1G321A2F-08
- 1.8 V and 1.5 V  $V_{DD}$  core voltage HYB18H1G321A2F-08
- Monolithic 1Gbit GDDR3 with an internally programmable organization of either two separate 512MBit memories (2048 K x 32 I/O x 8 banks) with separate Chip Select, or one 1Gb memory (4096 K x 32 I/O x 8 banks)
- Two CS: 4096 rows and 512 columns (128 burst start locations) per bank
- One CS: 8192 rows and 512 columns (128 burst start locations) per bank
- Differential clock inputs (CLK and  $\overline{\text{CLK}}$ )
- CAS latencies of 7, 8, 9, 10, 11, 12, 13, 14, 15, 16, 17
- Write latencies of 3, 4, 5, 6, 7
- Burst sequence with length of 4, 8
- 4n pre fetch
- Short RAS to CAS timing for Writes
- $t_{RAS}$  Lockout support
- $t_{WR}$  programmable for Writes with Auto-Precharge
- Data mask for write commands
- Single ended READ strobe (RDQS) per byte. RDQS edge-aligned with READ data
- Single ended WRITE strobe (WDQS) per byte. WDQS center-aligned with WRITE data
- DLL aligns RDQS and DQ transitions with Clock
- Programmable IO interface including on chip termination (ODT)
- Autoprecharge option with concurrent auto precharge support
- 8k Refresh (32ms)
- Autorefresh and Self Refresh
- PG-TFBGA-136 package
- Calibrated output drive. Active termination support
- RoHS Compliant Product <sup>1)</sup>

1) RoHS Compliant Product: Restriction of the use of certain hazardous substances (RoHS) in electrical and electronic equipment as defined in the directive 2002/95/EC issued by the European Parliament and of the Council of 27 January 2003. These substances include mercury, lead, cadmium, hexavalent chromium, polybrominated biphenyls and polybrominated biphenyl ethers.

HYB18H1G321A2F  
1-Gbit GDDR3 Graphics RAM**TABLE 1**  
Ordering Information

Part Number <sup>1)</sup>	Organization	Clock (MHz)	Package
HYB18H1G321A2F-08	x32	1200 @ CL15, 1.8 V	PG-TFBGA-136
		900 @ CL11, 1.5 V	
HYB18H1G321A2F-10	x32	1000 @ CL12, 1.8 V	
		800 @ CL10, 1.5 V	
HYB18H1G321A2F-14	x32	700 @ CL10, 1.8 V	
		700 @ CL10, 1.5 V	

- 1) HYB: designator for memory components  
18H:  $V_{DD}/V_{DDQ} = 1.8V$   
1G: 1 Gbit  
32: x32 organization  
A2: Product Revision  
F: Lead and Halogen-Free



## 1.2 Description

The Qimonda 1-Gbit GDDR3 Graphics RAM is a high speed memory device, designed for high bandwidth intensive applications like PC graphics systems. The chip is programmable into two different configurations. In the default mode the architecture is organized as two 512 Mbit memories of 8 banks, each (two CS mode). In an alternate configuration, it behaves as a conventional, 8-bank 1 Gbit DRAM (one CS mode).

HYB18H1G321A2F uses a double data rate interface and a  $4n$ -pre fetch architecture. The GDDR3 interface transfers two 32 bit wide data words per clock cycle to/from the I/O pins. Corresponding to the  $4n$ -pre fetch a single write or read access consists of a 128 bit wide, one-clock-cycle data transfer at the internal memory core and four corresponding 32 bit wide, one-half-clock-cycle data transfers at the I/O pins.

Single-ended unidirectional Read and Write Data strobes are transmitted simultaneously with Read and Write data respectively in order to capture data properly at the receivers of both the Graphics SDRAM and the controller. Data strobes are organized per byte of the 32 bit wide interface. For read commands the RDQS are edge-aligned with data, and the WDQS are center-aligned with data for write commands.

The HYB18H1G321A2F operates from a differential clock (CLK and  $\overline{\text{CLK}}$ ). Commands (addresses and control signals) are registered at every positive edge of CLK. Input data is registered on both edges of WDQS, and output data is referenced to both edges of RDQS.

In this document references to “the positive edge of CLK” imply the crossing of the positive edge of CLK and the negative edge of  $\overline{\text{CLK}}$ . Similarly, the “negative edge of CLK” refers to the crossing of the negative edge of CLK and the positive edge of  $\overline{\text{CLK}}$ . References to RDQS are to be interpreted as any or all RDQS<3:0>. WDQS, DM and DQ should be interpreted in a similar fashion.

Read and write accesses to the HYB18H1G321A2F are burst oriented. The burst length is fixed to 4 and 8 and the two least significant bits of the burst address are “Don’t Care” and internally set to LOW. Accesses begin with the registration of an ACTIVATE command, which is then followed by a READ or WRITE command. The address bits registered coincident with the ACTIVATE command are used to select the bank and the row to be accessed. The address bits registered coincident with the READ or WRITE command are used to select the bank and the column location for the burst access. In two CS mode, each of the 2 x 8 banks consists of 4096 row locations and 512 column locations. In one CS mode, the number of row locations doubles to 8192 rows while the number of column location remains unchanged at 512 columns. An AUTO PRECHARGE function can be combined with READ and WRITE to provide a self-timed row precharge that is initiated at the end of the burst access. The pipe lined, multibank architecture of the HYB18H1G321A2F allows for concurrent operation, thereby providing high effective bandwidth by hiding row precharge and activation time.

The “On Die Termination” interface (ODT) is optimized for high frequency digital data transfers and is internally controlled. The termination resistor value can be set using an external ZQ resistor or disabled through the Extended Mode Register.

The output driver impedance can be set using the Extended Mode Register. It can either be set to ZQ / 6 (auto calibration) or to 35, 40 or 45 Ohms.

Auto Refresh and Power Down with Self Refresh operations are supported.

An industrial standard PG-TFBGA-136 package is used which enables ultra high speed data transfer rates and a simple upgrade path from former DDR Graphics SDRAM products.



## 2 Configuration

**FIGURE 1**

**Ballout 1-Gbit GDDR3 Graphics RAM in 1-CS mode in non Merged Mode(Top View; MF = Low)**

1	2	3	4	5	6	7	8	9	10	11	12
$V_{DDQ}$	$V_{DD}$	$V_{SS}$	ZQ					MF	$V_{SS}$	$V_{DD}$	$V_{DDQ}$
$V_{SSQ}$	DQ0	DQ1	$V_{SSQ}$					$V_{SSQ}$	DQ9	DQ8	$V_{SSQ}$
$V_{DDQ}$	DQ2	DQ3	$V_{DDQ}$					$V_{DDQ}$	DQ11	DQ10	$V_{DDQ}$
$V_{SSQ}$	WDQS0	RDQS0	$V_{SSQ}$					$V_{SSQ}$	RDQS1	WDQS1	$V_{SSQ}$
$V_{DDQ}$	DQ4	DM0	$V_{DDQ}$					$V_{DDQ}$	DM1	DQ12	$V_{DDQ}$
$V_{DD}$	DQ6	DQ5	$\overline{\text{CAS}}$					$\overline{\text{CS0}}$	DQ13	DQ14	$V_{DD}$
$V_{SS}$	$V_{SSQ}$	DQ7	BA0					BA1	DQ15	$V_{SSQ}$	$V_{SS}$
$V_{REF}$	A1	$\overline{\text{RAS}}$	CKE					$\overline{\text{WE}}$	BA2	A5	$V_{REF}$
$V_{SS}$	A12	RAR	$V_{DDQ}$					$V_{DDQ}$	$\overline{\text{CK}}$	CK	$V_{SS}$
$V_{DD}$	A10	A2	A0					A4	A6	A8/AP	$V_{DD}$
$V_{SS}$	$V_{SSQ}$	DQ25	A11					A7	DQ17	$V_{SSQ}$	$V_{SS}$
$V_{DD}$	DQ24	DQ27	A3					A9	DQ19	DQ16	$V_{DD}$
$V_{DDQ}$	DQ26	DM3	$V_{DDQ}$					$V_{DDQ}$	DM2	DQ18	$V_{DDQ}$
$V_{SSQ}$	WDQS3	RDQS3	$V_{SSQ}$					$V_{SSQ}$	RDQS2	WDQS2	$V_{SSQ}$
$V_{DDQ}$	DQ28	DQ29	$V_{DDQ}$					$V_{DDQ}$	DQ21	DQ20	$V_{DDQ}$
$V_{SSQ}$	DQ30	DQ31	$V_{SSQ}$					$V_{SSQ}$	DQ23	DQ22	$V_{SSQ}$
$V_{DDQ}$	$V_{DD}$	$V_{SS}$	SEN					RESET	$V_{SS}$	$V_{DD}$	$V_{DDQ}$

MPPG0330



**FIGURE 2**

**Ballout 1-Gbit GDDR3 Graphics RAM in 2-CS mode in non Merged Mode(Top View; MF = Low)**

1	2	3	4	5	6	7	8	9	10	11	12
$V_{DDQ}$	$V_{DD}$	$V_{SS}$	ZQ					MF	$V_{SS}$	$V_{DD}$	$V_{DDQ}$
$V_{SSQ}$	DQ0	DQ1	$V_{SSQ}$					$V_{SSQ}$	DQ9	DQ8	$V_{SSQ}$
$V_{DDQ}$	DQ2	DQ3	$V_{DDQ}$					$V_{DDQ}$	DQ11	DQ10	$V_{DDQ}$
$V_{SSQ}$	WDQS0	RDQS0	$V_{SSQ}$					$V_{SSQ}$	RDQS1	WDQS1	$V_{SSQ}$
$V_{DDQ}$	DQ4	DM0	$V_{DDQ}$					$V_{DDQ}$	DM1	DQ12	$V_{DDQ}$
$V_{DD}$	DQ6	DQ5	$\overline{\text{CAS}}$					$\overline{\text{CS0}}$	DQ13	DQ14	$V_{DD}$
$V_{SS}$	$V_{SSQ}$	DQ7	BA0					BA1	DQ15	$V_{SSQ}$	$V_{SS}$
$V_{REF}$	A1	$\overline{\text{RAS}}$	CKE					$\overline{\text{WE}}$	BA2	A5	$V_{REF}$
$V_{SS}$	RAR	$\overline{\text{CS1}}$	$V_{DDQ}$					$V_{DDQ}$	$\overline{\text{CK}}$	CK	$V_{SS}$
$V_{DD}$	A10	A2	A0					A4	A6	A8/AP	$V_{DD}$
$V_{SS}$	$V_{SSQ}$	DQ25	A11					A7	DQ17	$V_{SSQ}$	$V_{SS}$
$V_{DD}$	DQ24	DQ27	A3					A9	DQ19	DQ16	$V_{DD}$
$V_{DDQ}$	DQ26	DM3	$V_{DDQ}$					$V_{DDQ}$	DM2	DQ18	$V_{DDQ}$
$V_{SSQ}$	WDQS3	RDQS3	$V_{SSQ}$					$V_{SSQ}$	RDQS2	WDQS2	$V_{SSQ}$
$V_{DDQ}$	DQ28	DQ29	$V_{DDQ}$					$V_{DDQ}$	DQ21	DQ20	$V_{DDQ}$
$V_{SSQ}$	DQ30	DQ31	$V_{SSQ}$					$V_{SSQ}$	DQ23	DQ22	$V_{SSQ}$
$V_{DDQ}$	$V_{DD}$	$V_{SS}$	SEN					RESET	$V_{SS}$	$V_{DD}$	$V_{DDQ}$

MPPG0340



**FIGURE 3**  
Ballout 1Gbit GDDR3 Graphics RAM in Merged Mode

1	2	3	4	5	6	7	8	9	10	11	12
$V_{DDQ}$	$V_{DD}$	$V_{SS}$	ZQ					MF	$V_{SS}$	$V_{DD}$	$V_{DDQ}$
$V_{SSQ}$	DQ0	DQ1	$V_{SSQ}$					$V_{SSQ}$	DQ9	DQ8	$V_{SSQ}$
$V_{DDQ}$	DQ2	DQ3	$V_{DDQ}$					$V_{DDQ}$	DQ11	DQ10	$V_{DDQ}$
$V_{SSQ}$	WDQS0	RDQS0	$V_{SSQ}$					$V_{SSQ}$	RDQS1	WDQS1	$V_{SSQ}$
$V_{DDQ}$	DQ4	DM0	$V_{DDQ}$					$V_{DDQ}$	DM1	DQ12	$V_{DDQ}$
$V_{DD}$	DQ6	DQ5	$\overline{\text{CAS}}$					$\overline{\text{CS0}}$	DQ13	DQ14	$V_{DD}$
$V_{SS}$	$V_{SSQ}$	DQ7	BA0					BA1	DQ15	$V_{SSQ}$	$V_{SS}$
$V_{REF}$	A1	$\overline{\text{RAS}}$	CKE					$\overline{\text{WE}}$	BA2	A5	$V_{REF}$
$V_{SS}$	RFU	A12/ CS1	$V_{DDQ}$					$V_{DDQ}$	$\overline{\text{CK}}$	CK	$V_{SS}$
$V_{DD}$	A10	A2	A0					A4	A6	A8/AP	$V_{DD}$
$V_{SS}$	$V_{SSQ}$	DQ25	A11					A7	DQ17	$V_{SSQ}$	$V_{SS}$
$V_{DD}$	DQ24	DQ27	A3					A9	DQ19	DQ16	$V_{DD}$
$V_{DDQ}$	DQ26	DM3	$V_{DDQ}$					$V_{DDQ}$	DM2	DQ18	$V_{DDQ}$
$V_{SSQ}$	WDQS3	RDQS3	$V_{SSQ}$					$V_{SSQ}$	RDQS2	WDQS2	$V_{SSQ}$
$V_{DDQ}$	DQ28	DQ29	$V_{DDQ}$					$V_{DDQ}$	DQ21	DQ20	$V_{DDQ}$
$V_{SSQ}$	DQ30	DQ31	$V_{SSQ}$					$V_{SSQ}$	DQ23	DQ22	$V_{SSQ}$
$V_{DDQ}$	$V_{DD}$	$V_{SS}$	SEN					RESET	$V_{SS}$	$V_{DD}$	$V_{DDQ}$

MPPG0350





## 2.1 Ball Definition and Description

**TABLE 2**  
**Ball Description**

Ball	Type	Detailed Function
CLK, $\overline{\text{CLK}}$	Input	<b>Clock:</b> CLK and $\overline{\text{CLK}}$ are differential clock inputs. Address and command inputs are latched on the positive edge of CLK. Graphics SDRAM outputs (RDQS, DQs) are referenced to CLK. CLK and $\overline{\text{CLK}}$ are not internally terminated.
CKE	Input	<b>Clock Enable:</b> CKE HIGH activates and CKE LOW deactivates the internal clock and input buffers. Taking CKE LOW provides Power Down. If all banks are precharged, this mode is called Precharge Power Down and Self Refresh mode is entered if a Auto Refresh command is issued. If at least one bank is open, Active Power Down mode is entered and no Self Refresh is allowed. All input receivers except CLK, $\overline{\text{CLK}}$ and CKE are disabled during Power Down. In Self Refresh mode the clock receivers are disabled too. Self Refresh Exit is performed by setting CKE asynchronously HIGH. Exit of Power Down without Self Refresh is accomplished by setting CKE HIGH with a positive edge of CLK. The value of CKE is latched asynchronously by Reset during Power On to determine the value of the termination resistor of the address and command inputs. CKE is not allowed to go LOW during a RD, a WR or a snoop burst.
$\overline{\text{CS0}}$	Input	<b>Chip Select:</b> $\overline{\text{CS0}}$ enables the command decoder when low and disables it when high. When the command decoder is disabled, new commands with the exception of DTERDIS are ignored, but internal operations continue. In 2-CS mode, CS0 is exclusively used for MRS, EMRS and SREFEN.
$\overline{\text{CS1}}$	Input	<b>Chip Select:</b> $\overline{\text{CS1}}$ is only evaluated in 2-CS mode, and it is used as the chip-select signal for the second memory block.
$\overline{\text{RAS}}$ , $\overline{\text{CAS}}$ , $\overline{\text{WE}}$	Input	<b>Command Inputs:</b> Sampled at the positive edge of CLK, $\overline{\text{CAS}}$ , $\overline{\text{RAS}}$ , and $\overline{\text{WE}}$ define (together with corresponding $\overline{\text{CS}}$ ) the command to be executed.
DQ<0:31>	I/O	<b>Data Inputs/Outputs:</b> The DQ signals form the 32 bit data bus. During READs the balls are outputs and during WRITEs they are inputs. Data is transferred at both edges of RDQS.
DM<0:3>	Input	<b>Input Data Masks:</b> The DM signals are input mask signals for WRITE data. Data is masked when DM is sampled HIGH with the WRITE data. DM is sampled on both edges of WDQS. DM0 is for DQ<0:7>, DM1 is for DQ<8:15>, DM2 is for DQ<16:23> and DM3 is for DQ<24:31>. Although DM balls are input-only, their loading is designed to match the DQ and WDQS balls.
RDQS<0:3>	Output	<b>Read Data Strobes:</b> RDQSx are unidirectional strobe signals. During READs the RDQSx are transmitted by the Graphics SDRAM and edge-aligned with data. RDQS have preamble and postamble requirements. RDQS0 is for DQ<0:7>, RDQS1 for DQ<8:15>, RDQS2 for DQ<16:23> and RDQS3 for DQ<24:31>.
WDQS<0:3>	Input	<b>Write Data Strobes:</b> WDQSx are unidirectional strobe signals. During WRITEs the WDQSx are generated by the controller and center aligned with data. WDQS have preamble and postamble requirements. WDQS0 is for DQ<0:7>, WDQS1 for DQ<8:15>, WDQS2 for DQ<16:23> and WDQS3 for DQ<24:31>.



Ball	Type	Detailed Function
BA<0:2>	Input	<b>Bank Address Inputs:</b> BA select to which internal bank an ACTIVATE, READ, WRITE or PRECHARGE command is being applied. BA are also used to distinguish between the MODE REGISTER SET and EXTENDED MODE REGISTER SET commands.
A<0:11>	Input	<b>Address Inputs:</b> During ACTIVATE, A0-A11 defines the row address. For READ/WRITE, A2-A7 and A9 defines the column address, and A8 defines the auto precharge bit. If A8 is HIGH, the accessed bank is precharged after execution of the column access. If A8 is LOW, AUTO PRECHARGE is disabled and the bank remains active. Sampled with PRECHARGE, A8 determines whether one bank is precharged (selected by BA<0:2>, A8 LOW) or all 8 banks are precharged (A8 HIGH). During (EXTENDED) MODE REGISTER SET the address inputs define the register settings. A<0:11> are sampled with the positive edge of CLK.
A<12>	Input	<b>Address Inputs:</b> A12 define the MSB of the row address during an ACTIVATE in 1-CS mode.
ZQ	-	<b>ODT Impedance Reference:</b> The ZQ ball is used to control the ODT impedance.
RESET	Input	<b>Reset pin:</b> The RES pin is a $V_{DDQ}$ CMOS input. RES is not internally terminated. When RES is at LOW state the chip goes into full reset. The chip stays in full reset until RES goes to HIGH state. The Low to High transition of the RES signal is used to latch the CKE value to set the value of the termination resistors of the address and command inputs. After exiting the full reset a complete initialization is required since the full reset sets the internal settings to default, including mode register bits.
MF	Input	<b>Mirror function pin:</b> The MF pin is a $V_{DDQ}$ CMOS input. This pin must be hardwired on board either to a power or to a ground plane. With MF set to HIGH, the command and address pins are reassigned in order to allow for an easier routing on board for a back to back memory arrangement.
SEN	Input	<b>Enables Boundary Scan Functionality:</b> If Boundary Scan is not used PIN should be constantly connected to GND.
$V_{REF}$	Supply	<b>Voltage Reference:</b> $V_{REF}$ is the reference voltage input.
$V_{DD}, V_{SS}$	Supply	<b>Power Supply:</b> Power and Ground for the internal logic.
$V_{DDQ}, V_{SSQ}$	Supply	<b>I/O Power Supply:</b> Isolated Power and Ground for the output buffers to provide improved noise immunity.
NC, RFU	-	Please do not connect. Reserved for Future Use balls.
RAR		Reserved for Alternate Rank



## 2.2 Mirror Function

The GDDR3 Graphics RAM provides a ball mirroring feature that is enabled by applying a logic HIGH on ball MF. This function allows for efficient routing in a clam shell configuration.

Depending of the logic state applied on MF, the command and address signals will be assigned to different balls. The default ball configuration (see **Figure 1**, **Figure 2** and **Figure 3**) corresponds to MF = LOW. The CS1 and A12 balls are not mirrored. The DC level (HIGH or LOW) must be applied on the MF pin at power up and is not allowed to change after that.

**Table 3** shows the ball assignment as a function of the logic state applied on MF.

**TABLE 3**  
Ball Assignment with Mirror

MF Logic State		Signal
LOW	HIGH	
H3	H10	$\overline{\text{RAS}}$
F4	F9	$\overline{\text{CAS}}$
H9	H4	$\overline{\text{WE}}$
F9	F4	$\overline{\text{CS0}}$
H4	H9	CKE
K4	K9	A0
H2	H11	A1
K3	K10	A2
M4	M9	A3
K9	K4	A4
H11	H2	A5
K10	K3	A6
L9	L4	A7
K11	K2	A8
M9	M4	A9
K2	K11	A10
L4	L9	A11
G4	G9	BA0
G9	G4	BA1
H10	H3	BA2



## 2.3 Commands

### 2.3.1 Command Table

In the following table CKEn refers to the positive edge of CLK corresponding to the clock cycle when the command is given to the Graphics SDRAM. CKEn-1 refers to the previous positive edge of CLK. For all command and address inputs CKEn is implied.

All input states or sequences not shown are illegal or reserved.

**TABLE 4**  
Command Overview for 1-CS mode

Operation	Code	CKE <sub>n-1</sub>	CKE <sub>n</sub>	bCS0	bRAS	bCAS	bWE	BA0	BA1	BA2	A8	A2-7 A9-11/12	Note
Device Deselect	DESEL	H	H	H	L X H	X X H	X L H	X	X	X	X	X	1)
Data Terminator Disable	DTERDIS	H	H	H	H	L	H	X	X	X	X	X	1)2)
No Operation	NOP	H	H	L	H	H	H	X	X	X	X	X	
Mode Register Set	MRS	H	H	L	L	L	L	0	0	0	OPCODE		
Extended Mode Register Set	EMRS	H	H	L	L	L	L	1	0	OPCODE			
Extended Mode Register Set 2	EMRS2	H	H	L	L	L	L	0	1	0	OPCODE		
Extended Mode Register Set 3	EMRS3	H	H	L	L	L	L	1	1	0	OPCODE		
Bank Activate	ACT	H	H	L	L	H	H	BA	BA	BA	Row Adress		1)3)
Read	RD	H	H	L	H	L	H	BA	BA	BA	L	Col.	
Read w/ Autoprecharge	RD/A	H	H	L	H	L	H	BA	BA	BA	H	Col.	
Write	WR	H	H	L	H	L	L	BA	BA	BA	L	Col.	1)4)
Write w/ Autoprecharge	WR/A	H	H	L	H	L	L	BA	BA	BA	H	Col.	
Precharge	PRE	H	H	L	L	H	L	BA	BA	BA	L	X	1)4)
Precharge All	PREALL	H	H	L	L	H	L	X	X	X	H	X	
Auto Refresh	AREF	H	H	L	L	L	H	X	X	X	X	X	1)5)
Power Down Mode Entry	PWDNEN	H	L	H L	X H	X H	X H	X	X	X	X	X	1)6)
Power Down Mode Exit	PWDNEX	L	H	X	X	X	X	X	X	X	X	X	1)7)
Self Refresh Entry	SREFEN	H	L	L	L	L	H	X	X	X	X	X	1)8)
Self Refresh Exit	SREFEX	L	H	X	X	X	X	X	X	X	X	X	1)9)

- 1) X represents "Don't Care".
- 2) This command is invoked when a Read is issued on another DRAM rank placed on the same command bus. Cannot be in power-down or self-refresh state. The Read command will cause the data termination to be disabled.
- 3) BA0 - BA2 provide bank address, A0 - A11, A12 provide the row address.
- 4) BA0 - BA2 provide bank address, A2 - A7, A9 provide the column address, A8/AP controls Auto Precharge.



- 5) Auto Refresh and Self Refresh Entry differ only by the state of CKE.
- 6) PWDNEN is selected by issuing a DESEL or NOP at the first positive CLK edge following the HIGH to LOW transition of CKE.
- 7) First possible valid command after  $t_{XPN}$ . During  $t_{XPN}$  only NOP or DESEL commands are allowed.
- 8) Self Refresh is selected by issuing AREF at the first positive CLK edge following the HIGH to LOW transition of CKE.
- 9) First possible valid command after  $t_{XSC}$ . During  $t_{XSC}$  only NOP or DESEL commands are allowed.

**TABLE 5**  
Command Overview for 2-CS mode

Operation	Code	Ranks	CKE	CKE	bCS0	bCS1	bRAS	bCAS	bWE	BA0	BA1	BA2	A8	A2-7 A9-11	Note
			n-1												
Device Deselect	DESEL		H	H	H	H	L X H	X X H	X L H	X	X	X	X	X	<sup>1)</sup>
Data Terminator Disable	DTERDIS		H	H	H	H	H	L	H	X	X	X	X	X	<sup>1)2)</sup>
No Operation	NOP		H	H	L X	X L	H	H	H	X	X	X	X	X	
Mode Register Set	MRS		H	H	L	X	L	L	L	0	0	0	OPCODE		
Extended Mode Register Set	EMRS		H	H	L	X	L	L	L	1	0	OPCODE			
Extended Mode Register Set 2	EMRS2		H	H	L	X	L	L	L	0	1	0	OPCODE		
Extended Mode Register Set 3	EMRS3		H	H	L	X	L	L	L	1	1	0	OPCODE		
Bank Activate	ACT	MemBlock 1	H	H	L	H	L	H	H	BA	BA	BA	Row Address		<sup>1)3)</sup>
		MemBlock 2	H	H	H	L	L	H	H	BA	BA	BA	Row Address		
Read	RD	MemBlock 1	H	H	L	H	H	L	H	BA	BA	BA	L	Col.	<sup>1)4)</sup>
		MemBlock 2	H	H	H	L	H	L	H	BA	BA	BA	L	Col.	
Read w/ Autoprecharge	RD/A	MemBlock 1	H	H	L	H	H	L	H	BA	BA	BA	H	Col.	<sup>1)4)</sup>
		MemBlock 2	H	H	H	L	H	L	H	BA	BA	BA	H	Col.	
Write	WR	MemBlock 1	H	H	L	H	H	L	L	BA	BA	BA	L	Col.	<sup>1)4)</sup>
		MemBlock 2	H	H	H	L	H	L	L	BA	BA	BA	L	Col.	
Write w/ Autoprecharge	WR/A	MemBlock 1	H	H	L	H	H	L	L	BA	BA	BA	H	Col.	<sup>1)4)</sup>
		MemBlock 2	H	H	H	L	H	L	L	BA	BA	BA	H	Col.	
Precharge	PRE	MemBlock 1	H	H	L	H	L	H	L	BA	BA	BA	L	X	<sup>1)</sup>
		MemBlock 2	H	H	H	L	L	H	L	BA	BA	BA	L	X	
		Both	H	H	L	L	L	H	L	BA	BA	BA	L	X	
Precharge All	PREALL	MemBlock 1	H	H	L	H	L	H	L	X	X	X	H	X	<sup>1)</sup>
		MemBlock 2	H	H	H	L	L	H	L	X	X	X	H	X	
		Both	H	H	L	L	L	H	L	X	X	X	H	X	
Auto Refresh	AREF	MemBlock 1	H	H	L	H	L	L	H	X	X	X	X	X	<sup>1)5)</sup>
		MemBlock 2	H	H	H	L	L	L	H	X	X	X	X	X	
		Both	H	H	L	L	L	L	H	X	X	X	X	X	
Power Down Mode Entry	PWDNEN		H	L	H X L	H L X	X H	X H	X H	X	X	X	X	X	<sup>1)6)</sup>



HYB18H1G321A2F  
1-Gbit GDDR3 Graphics RAM

Operation	Code	Ranks	CKE	n-1	CKE	bCS0	bCS1	bRAS	bCAS	bWE	BA0	BA1	BA2	A8	A2-7 A9-11	Note
			L	H	X	X	X	X	X	X	X	X	X	X	X	
Power Down Mode Exit	PWDNEX		L	H	X	X	X	X	X	X	X	X	X	X	X	1)7)
Self Refresh Entry	SREFEN		H	L	L	L	L	L	H	X	X	X	X	X	X	1)8)
Self Refresh Exit	SREFEX		L	H	X	X	X	X	X	X	X	X	X	X	X	1)9)

- 1) X represents "Don't Care".
- 2) This command is invoked when a Read is issued on another DRAM rank placed on the same command bus. Cannot be in power-down or self-refresh state. The Read command will cause the data termination to be disabled. Refer to Figure 15 for timing.
- 3) BA0 - BA2 provide bank address, A0 - A11, A12 provide the row address.
- 4) BA0 - BA2 provide bank address, A2 - A7, A9 provide the column address, A8/AP controls Auto Precharge.
- 5) Auto Refresh and Self Refresh Entry differ only by the state of CKE.
- 6) PWDNEN is selected by issuing a DESEL or NOP at the first positive CLK edge following the HIGH to LOW transition of CKE.
- 7) First possible valid command after  $t_{XPN}$ . During  $t_{XPN}$  only NOP or DESEL commands are allowed.
- 8) Self Refresh is selected by issuing AREF at the first positive CLK edge following the HIGH to LOW transition of CKE.
- 9) First possible valid command after  $t_{XSC}$ . During  $t_{XSC}$  only NOP or DESEL commands are allowed.



## 2.4 Truth Tables

### 2.4.1 Function Truth Table for more than one Activated Bank

If there is more than one bank activated in the Graphics SDRAM, some commands can be performed in parallel due to the chip's multibank architecture. The following table defines for which commands such a scheme is possible. All other transitions are illegal. Notes 1-11 define the start and end of the actions belonging to a submitted command. This table is based on the assumption that there are no other actions ongoing on bank n or bank m. If there are any actions ongoing on a third bank  $t_{RRD}$ ,  $t_{RTW}$  and  $t_{WTR}$  have to be taken always into account.

**TABLE 6**  
Function Truth Table I

Current State	Ongoing action on bank n	Possible action in parallel on bank m
ACTIVE	ACTIVATE <sup>1)</sup>	ACT, PRE, WRITE, WRITE/A, READ, READ/A <sup>2)</sup>
	WRITE <sup>3)</sup>	ACT, PRE, WRITE, WRITE/A, READ, READ/A <sup>4)</sup>
	WRITE/A <sup>5)</sup>	ACT, PRE, WRITE, WRITE/A, READ <sup>6)</sup>
	READ <sup>7)</sup>	ACT, PRE, WRITE, WRITE/A, READ, READ/A <sup>8)</sup>
	READ/A <sup>9)</sup>	ACT, PRE, WRITE, WRITE/A, READ, READ/A <sup>8)</sup>
	PRECHARGE <sup>10)</sup>	ACT, PRE, WRITE, WRITE/A, READ, READ/A <sup>11)</sup>
	PRECHARGE ALL <sup>10)</sup>	-
	POWER DOWN ENTRY <sup>12)</sup>	-
IDLE	ACTIVATE 1)	ACT
	POWER DOWN ENTRY <sup>12)</sup>	-
	AUTO REFRESH <sup>13)</sup>	-
	SELF REFRESH ENTRY <sup>12)</sup>	-
	MODE REGISTER SET (MRS) <sup>14)</sup>	-
	EXTENDED MRS <sup>14)</sup>	-
	EXTENDED MRS 2 <sup>14)</sup>	-
POWER DOWN	POWER DOWN EXIT <sup>15)</sup>	-
SELF REFRESH	SELF REFRESH EXIT <sup>16)</sup>	-

- 1) Action ACTIVATE starts with issuing the command and ends after  $t_{RCD}$ .
- 2) During action ACTIVATE an ACT command on another bank is allowed considering  $t_{RRD}$  or  $t_{RRD\_RR}$ , a PRE command on another bank is allowed any time. WR, WR/A, RD and RD/A are always allowed.
- 3) Action WRITE starts with issuing the command and ends  $t_{WR}$  after the first pos. edge of CLK following the last falling WDQS edge.
- 4) During action WRITE an ACT or a PRE command on another bank is allowed any time. A new WR or WR/A command on another bank must be separated by at least one NOP from the ongoing WRITE. RD or RD/A are not allowed before  $t_{WTR}$  or  $t_{WTR\_RR}$  is met.
- 5) Action WRITE/A starts with issuing the command and ends  $t_{WR}$  after the first positive edge of CLK following the last falling WDQS edge.
- 6) During action WRITE/A an ACT or a PRE command on another bank is allowed any time. A new WR or WR/A command on another bank has to be separated by at least one NOP from the ongoing command. RD is not allowed before or  $t_{WTR}$  or  $t_{WTR\_RR}$  is met. RD/A is not allowed during an ongoing WRITE/A action.
- 7) Action READ starts with issuing the command and ends with the first positive edge of CLK following the last falling edge of RDQS.
- 8) During action READ and READ/A an ACT or a PRE command on another bank is allowed any time. A new RD or RD/A command on another bank has to be separated by at least one NOP from the ongoing command. A WR or WR/A command on another bank has to meet  $t_{RTW}$ .
- 9) Action READ/A starts with issuing the command and ends with the first positive edge of CLK following the last falling edge of RDQS.



- 10) Action PRECHARGE and PRECHARGE ALL start with issuing the command and ends after  $t_{RP}$ .
- 11) During Action ACTIVE an ACT command on another banks is allowed considering  $t_{RRD}$  or  $t_{RRD\_RR}$ . A PRE command on another bank is allowed any time. WR, WR/A, RD and RD/A are always allowed.
- 12) During POWER DOWN and SELF REFRESH only the EXIT commands are allowed.
- 13) AUTO REFRESH starts with issuing the command and ends after  $t_{RFC}$ .
- 14) Actions MODE REGISTER SET, EXTENDED MODE REGISTER SET and EXTENDED MODE REGISTER 2 SET start with issuing the command and ends after  $t_{MRD}$ .
- 15) Action POWER DOWN EXIT starts with issuing the command and ends after  $t_{XPN}$ .
- 16) Action SELF REFRESH EXIT starts with issuing the command and ends after  $t_{XSC}$ .

## 2.5 Function Truth Table for CKE

**TABLE 7**  
Function Truth Table II (CKE Table)

CKE N-1	CKE n	CURRENT STATE	COMMAND	ACTION
L	L	Power Down	X	Stay in Power Down
		Self Refresh	X	Stay in Self Refresh
L	H	Power Down	DESEL or NOP	Exit Power Down
		Self Refresh	DESEL or NOP	Exit Self Refresh <sup>5</sup>
H	L	All Banks Idle	DESEL or NOP	Entry Precharge Power Down
		Bank(s) Active	DESEL or NOP	Entry Active Power Down
		All Banks Idle	Auto Refresh	Entry Self Refresh

### Notes

1.  $CKE_n$  is the logic step at clock edge  $n$ ;  $CKE_{n-1}$  was the state of CKE at the previous clock edge.
2. Current state is the state of the GDDR3 Graphics RAM immediately prior to clock edge  $n$ .
3. COMMAND is the command registered at clock edge  $n$ , and ACTION is a result of COMMAND.
4. All states and sequences not shown are illegal or reserved.
5. DESEL or NOP commands should be issued on any clock edges occurring during the  $t_{XSR}$  period. A minimum of 1000 clock cycles is required before applying any other valid command.





## 3 Boundary Scan

### 3.1 General Description

The 1-Gbit GDDR3 incorporates a modified boundary scan test mode. This mode doesn't operate in accordance with IEEE Standard 1149.1-1990. To save the current GDDR3 ball-out, this mode will scan the parallel data input and output the scanned data through the WDQS0 pin controlled by SEN.

*Note: Both pads bCS1 and A12 will be activated and could be accessed during Boundary Scan.*

### 3.2 Disabling the scan feature

It is possible to operate the GDDR3 without using the boundary scan feature. SEN (at U-4 of 136- ball package) should be tied LOW(VSS) to prevent the device from entering the boundary scan mode. The other pins which are used for scan mode, RES, MF, WDQS0 and  $\overline{CS}$  will be operating at normal GDDR3 functionalities when SEN is deasserted.

**TABLE 8**  
Boundary Scan Exit Order

BIT#	BALL	BIT#	BALL	BIT#	BALL	BIT#	BALL	BIT#	BALL	BIT#	BALL
1	D-3	13	E-10	25	K-11	37	R-10	49	L-3	61	G-4
2	C-2	14	F-10	26	K-10	38	T-11	50	M-2	62	F-4
3	C-3	15	E-11	27	K-9	39	T-10	51	M-4	63	F-2
4	B-2	16	G-10	28	M-9	40	T-3	52	K-4	64	G-3
5	B-3	17	F-11	29	M-11	41	T-2	53	K-3	65	E-2
6	A-4	18	G-9	30	L-10	42	R-3	54	K-2	66	F-3
7	B-10	19	H-9	31	N-11	43	R-2	55	L-4	67	E-3
8	B-11	20	H-10	32	M-10	44	P-3	56	J-3		
9	C-10	21	H-11	33	N-10	45	P-2	57	J-2		
10	C-11	22	J-11	34	P-11	46	N-3	58	H-2		
11	D-10	23	J-10	35	P-10	47	M-3	59	H-3		
12	D-11	24	L-9	36	R-11	48	N-2	60	H-4		

#### Notes

1. When the device is in scan mode, the mirror function will be disabled and none of the pins are remapped.
2. Since the other input of the MUX for DM0 tied to GND, the device will output the continuous zeros after scanning a bit #67, if the chip stays in scan shift mode.
3. An unconnected CS1 and A12 on the board will be read as undefined.

**TABLE 9**  
Scan Pin Description

PACKAGE BALL	SYMBOL	NORMAL FUNCTION	TYPE	DESCRIPTION
V-9	SSH	RES	Input	<b>Scan Shift:</b> Capture the data input from the pad at logic LOW and shift the data on the chain at logic HIGH.
F-9	SCK	$\overline{\text{CS}}$	Input	<b>Scan Clock:</b> Not a true clock, could be a single pulse or series of pulses. All scan inputs will be referenced to rising edge of the scan clock
D-2	SOUT	WDQS0	Output	<b>Scan Output</b>
V-4	SEN	SEN	Input	<b>Scan Enable:</b> Logic HIGH enables the device into scan mode and will be disabled at logic LOW. Must be tied to GND when not in use.
A-9	$\overline{\text{SOE}}$	MF	Input	<b>Scan Output Enable:</b> Enables (registered LOW) and disables (registered HIGH) SOUT data. This pin will be tied to $V_{DD}$ or GND through a resistor (typically 1 K $\Omega$ for normal operation). Tester needs to overdrive this pin to guarantee the required input logic level in scan mode.

**Notes**

1. When SEN is asserted, no commands are to be executed by the GDDR3. This applies both to user commands and manufacturing commands which may exist while RES is deasserted.
2. The Scan Function can be used right after bringing up  $V_{DD} / V_{DDQ}$  of the device. No initialization sequence of the device is required. After leaving the Scan Function it is required to run through the complete initialization sequence.
3. In Scan Mode all terminations for CMD/ADD and DQ, DM, RDQS and WDQS are switched off.
4. In a double-load clam-shell configuration, SEN will be asserted to both devices. Separate two  $\overline{\text{SOE}}$ 's should be provided to top and bottom devices to access the scanned output. When either of the devices is in scan mode,  $\overline{\text{SOE}}$  for the other device which is not in a scan will be disabled.



## 4 Functional Description

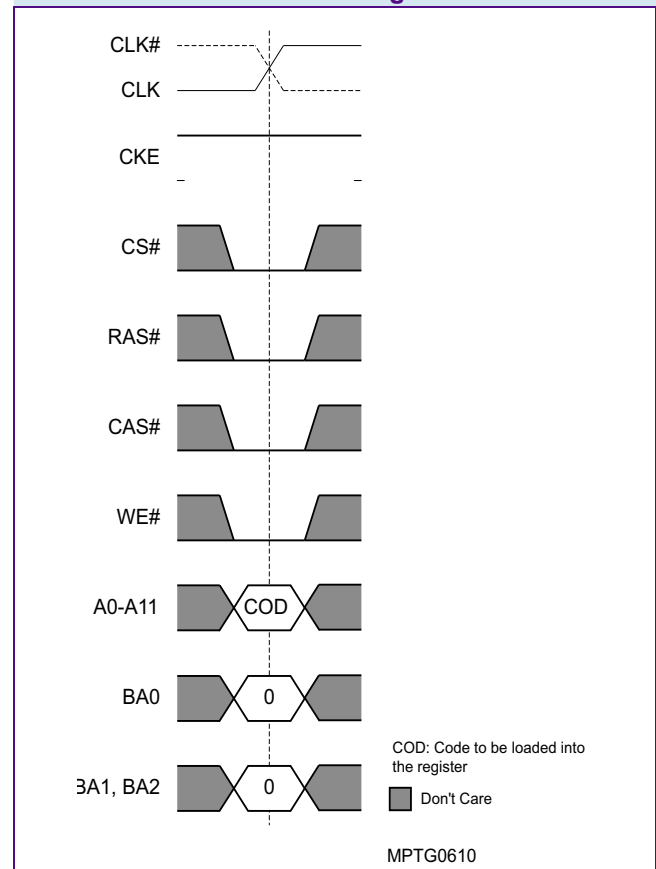
### 4.1 Mode Register Set Command (MRS)

The Mode Register stores the data for controlling the operation modes of the memory. It programs CAS latency, test mode, DLL Reset, the value of the Write Latency and the Burst length. The Mode Register must be written after power up to operate the SGRAM. During a Mode Register Set command the address inputs are sampled and stored in the Mode Register. The Mode Register content can only be set or changed when the chip is in Idle state. For non-READ commands following a Mode Register Set a delay of  $t_{MRD}$  must be met.

To apply an MRS command, CS0 has to be used.

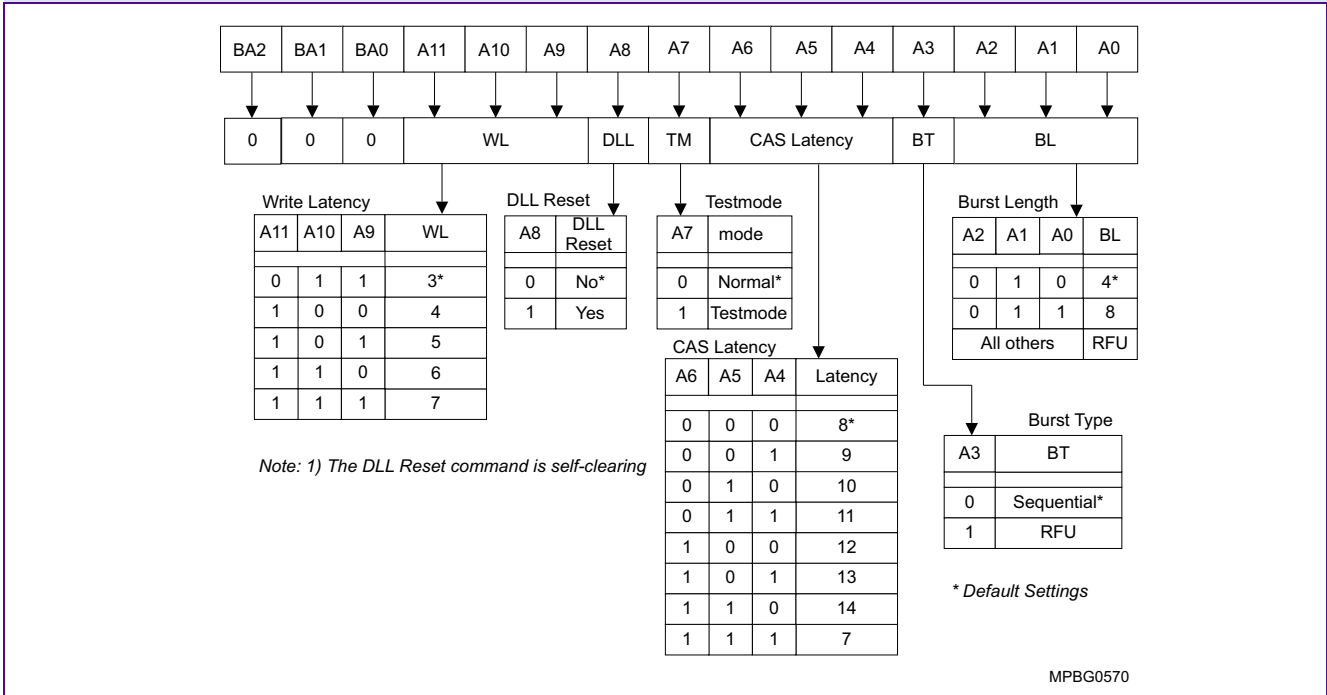
The Mode Register Bitmap is supported in two configurations. The first configuration is intended to support the Mid-Range-Speed application. The second configuration supports higher clock cycles for CAS latency and is therefore prepared to support high-speed application. The selected configuration is defined by Bit0 of EMRS2.

**FIGURE 4**  
Mode Register Set Command

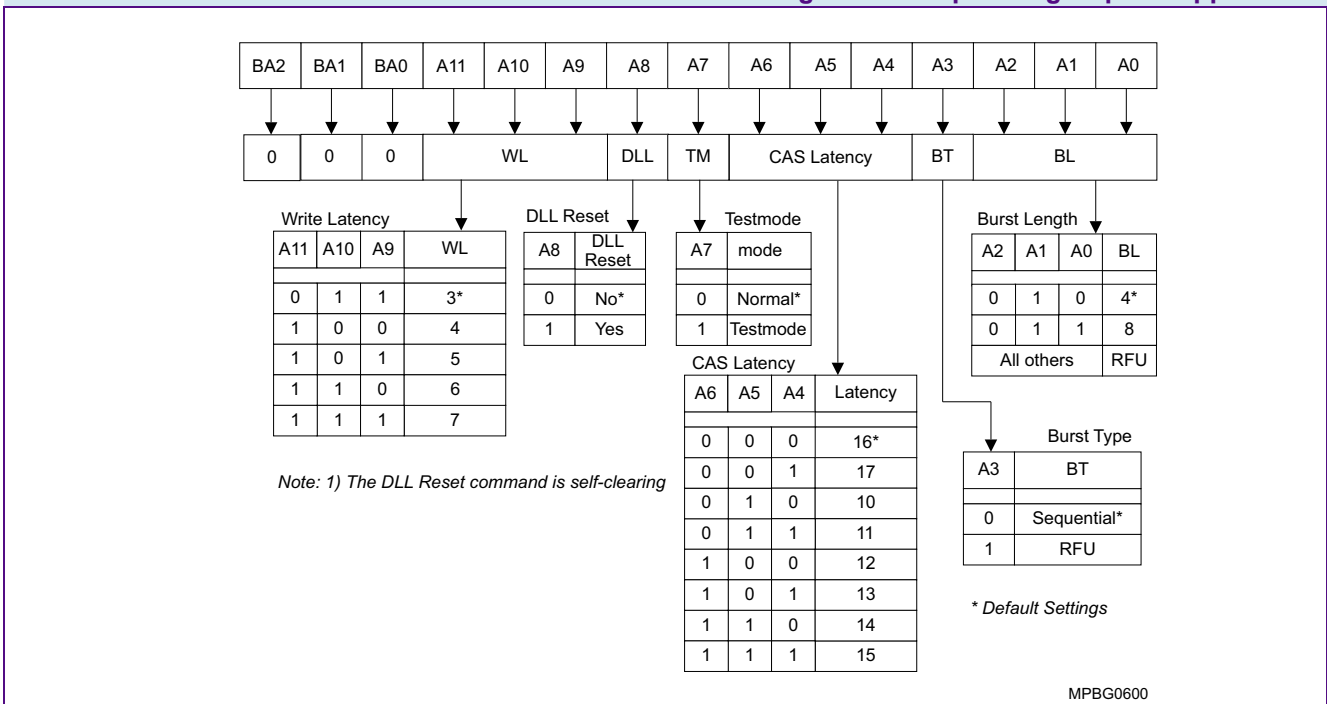




**FIGURE 5**  
**Mode Register Bitmap for Mid-Range-Speed Application**

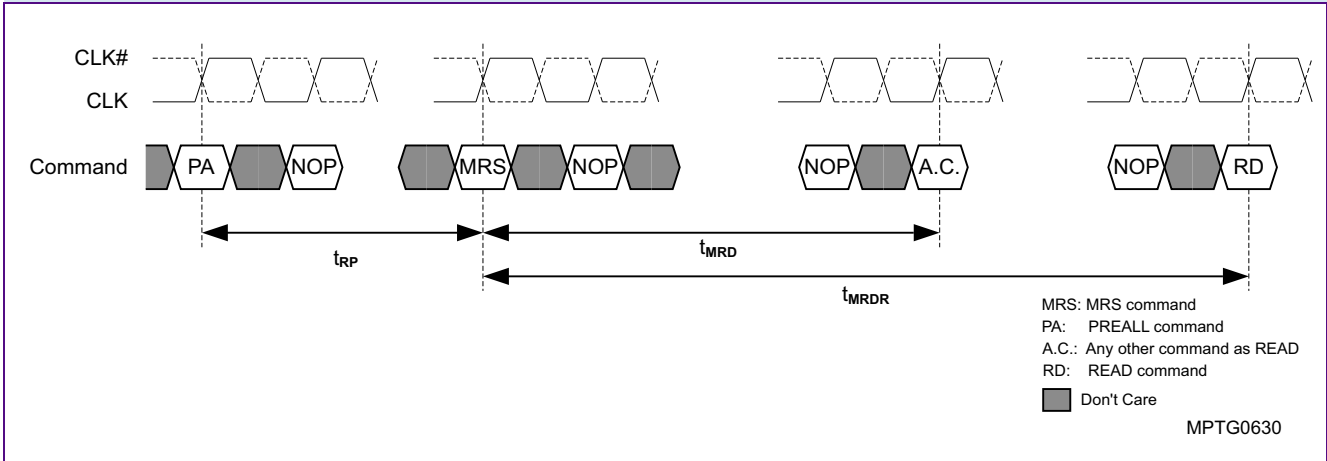


**FIGURE 6**  
**Mode Register Bitmap for High-Speed Application**





**FIGURE 7**  
Mode Register Set Timing



### 4.1.1 Burst length

Read and Write accesses to the GDDR3 Graphics RAM are burst oriented with burst length of 4 and 8. This value must be programmed using the Mode Register Set command (A0 .. A2). The burst length determines the number of column locations that can be accessed for a given READ or WRITE command.

When a READ or WRITE command is issued, a block of columns equal to the burst length is effectively selected. All accesses for that burst take place within this block if a boundary is reached. The starting location within this block is determined by the two least significant bits A0 and A1 which are set internally to the fixed value of zero each. Reserved states should not be used, as unknown operation or incompatibility with future versions may result.

### 4.1.2 Burst type

Accesses within a given bank must be programmed to be sequential. This is done using the Mode Register Set command (A3). This device does not support the burst interleave mode.

**TABLE 10**  
Burst Definition

Burst Length	Starting Column Address			Order of Accesses within a Burst (Type = sequential)
	A2	A1	A0	
4	—	X	X	0-1-2-3
8	0	X	X	0-1-2-3-4-5-6-7
	1	X	X	4-5-6-7-0-1-2-3

The value applied at the balls A0 and A1 for the column address is “Don’t care”.



### 4.1.3 CAS Latency

The CAS latency (CL) is the delay, in clock cycles, between the registration of a READ command and the availability of the first bit of output data.

If a READ command is registered at clock edge  $n$ , and the latency is  $m$  clocks, the data will be available nominally coincident with clock edge  $n+m$ .

Reserved states should not be used as unknown operation or incompatibility with future versions may result.

### 4.1.4 Write Latency

The WRITE latency, WL, is the delay, in clock cycles, between the registration of a WRITE command and the availability of the first bit of input data.

### 4.1.5 Test mode

The normal operating mode is selected by issuing a Mode Register Set command with bit A7 set to zero and bits A0-A6 and A8-A11 set to the desired value.

### 4.1.6 DLL Reset

The normal operating mode is selected by issuing a Mode Register Set command with bit A8 set to zero and bits A0-A7 and A9-A11 set to the desired values. A DLL Reset is initiated by issuing a Mode Register Set command with bit A8 set to one and bits A0-A7 and A9-A11 set to the desired values. The GDDR3 Graphics RAM returns automatically in the normal mode of operations once the DLL reset is completed.



## 4.2 Extended Mode Register Set Command (EMRS1)

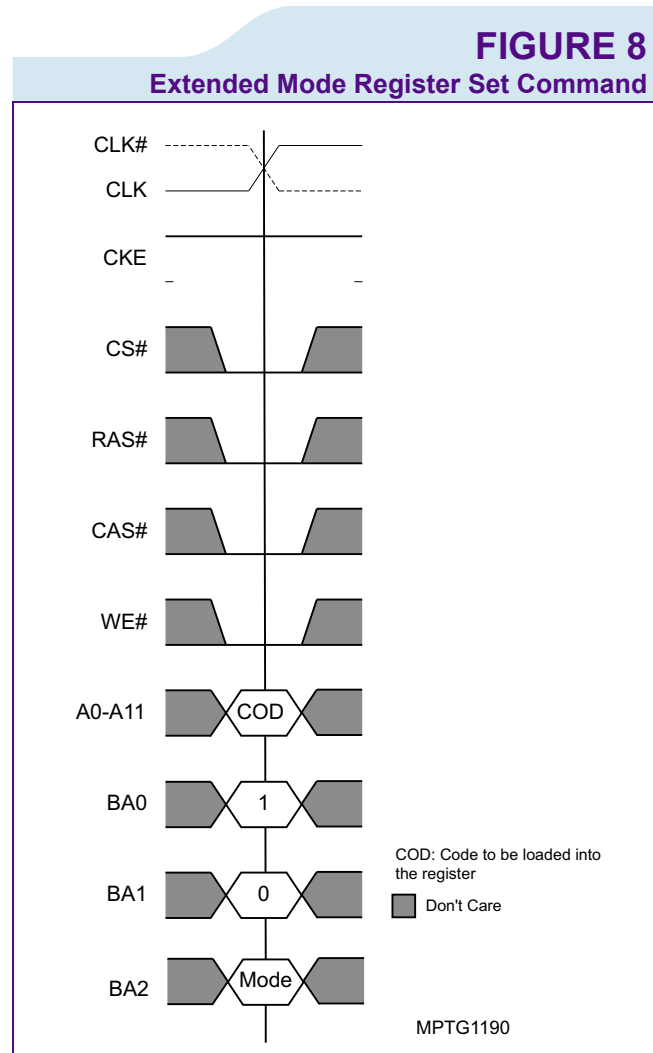
The Extended Mode Register is used to control multiple operation modes of the device. The most important one is the organization as a 1-CS or a 2-CS device. Furthermore, it is used to set the output driver impedance value, the termination impedance value, the Write Recovery time value for Write with Autoprecharge. It is used as well to enable/disable the DLL, to issue the Vendor ID. There is no default value for the Extended Mode Register. Therefore it must be written after power up to operate the GDDR3 Graphics RAM.

The Extended Mode Register can be programmed by performing a normal Mode Register Set operation and setting the BA0 bit to HIGH. All other bits of the EMR register are reserved and should be set to LOW.

The Extended Mode Register must be loaded when all banks are idle and no burst are in progress. The controller must wait the specified time  $t_{MRD}$  before initiating any subsequent operation (Figure 10).

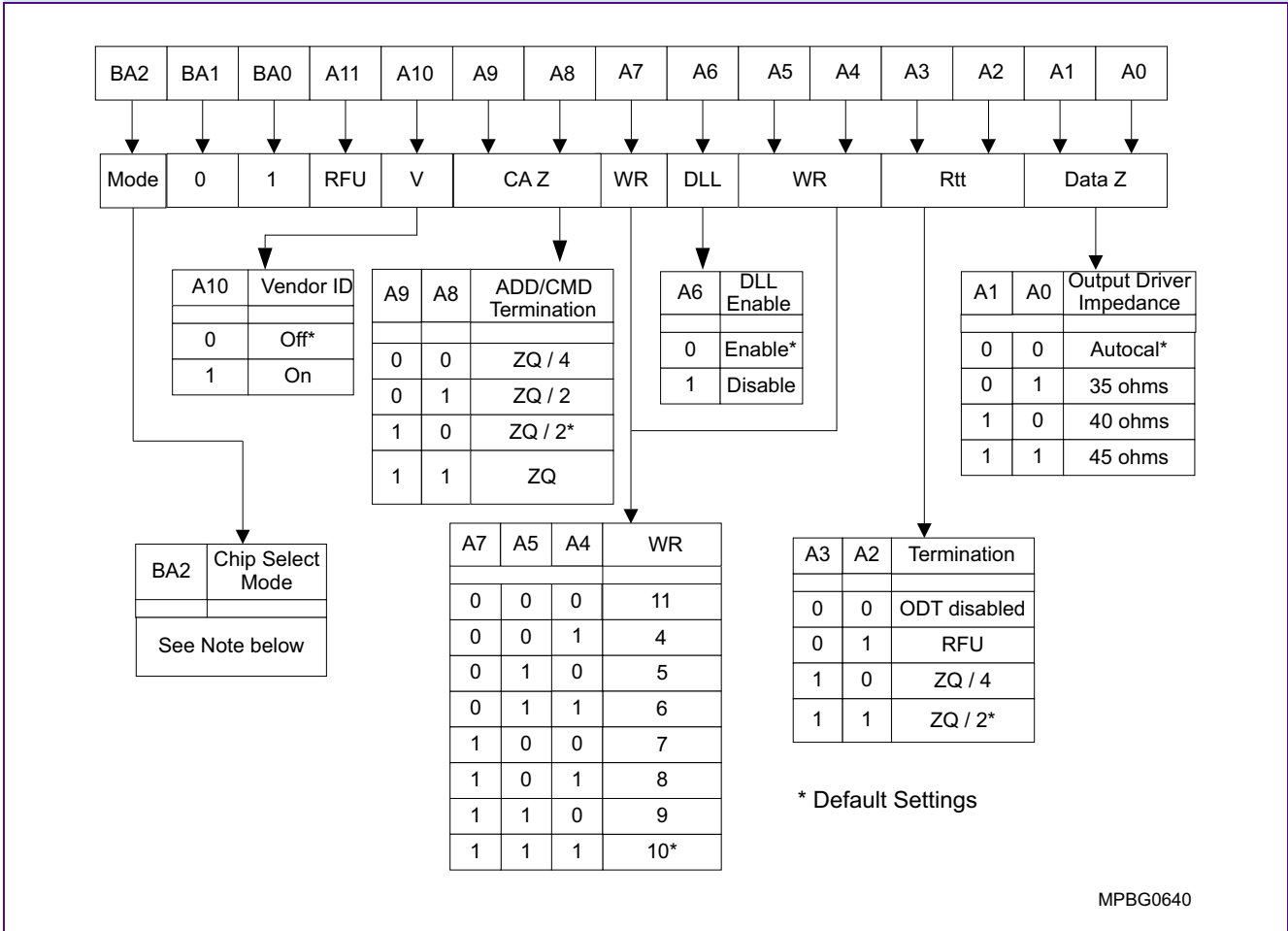
The timing of the EMRS command operation is equivalent to the timing of the MRS command operation.

To apply an EMRS command, CS0 has to be used.





**FIGURE 9**  
**Extended Mode Register Bitmap for Mid-Range-Speed Application**



**Notes**

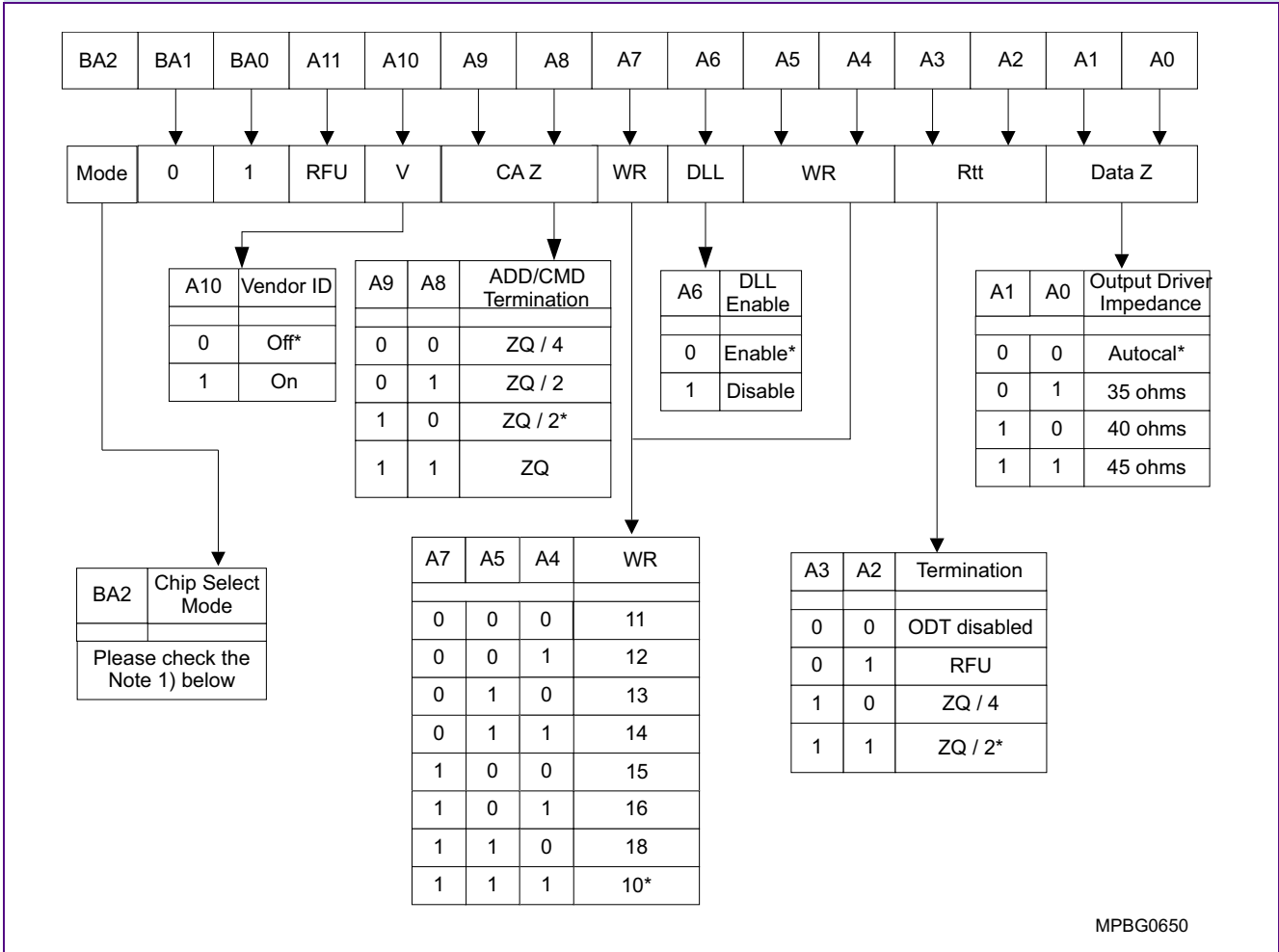
1. This device supports two operation modes: 1-CS mode or 2-CS mode. For detail configurations and mode selection in relation to signals and ballouts. Please refer to **Section 4.2.7** for further details.

There are two bitmaps for the Extended Mode Register. One bitmap shown in **Figure 9** is supposed to support Mid-Range-Speed applications. The other bitmap shown in **Figure 10** is more focused on the high-speed application. Both bitmaps distinguish different numbers in supported Write Recovery clock cycles. The mid-range bit map provides WR cycles from 4 to 11. The high-speed bitmap supports WR from 7 to 13.





**FIGURE 10**  
Extended Mode Register Bitmap for High-Speed Application

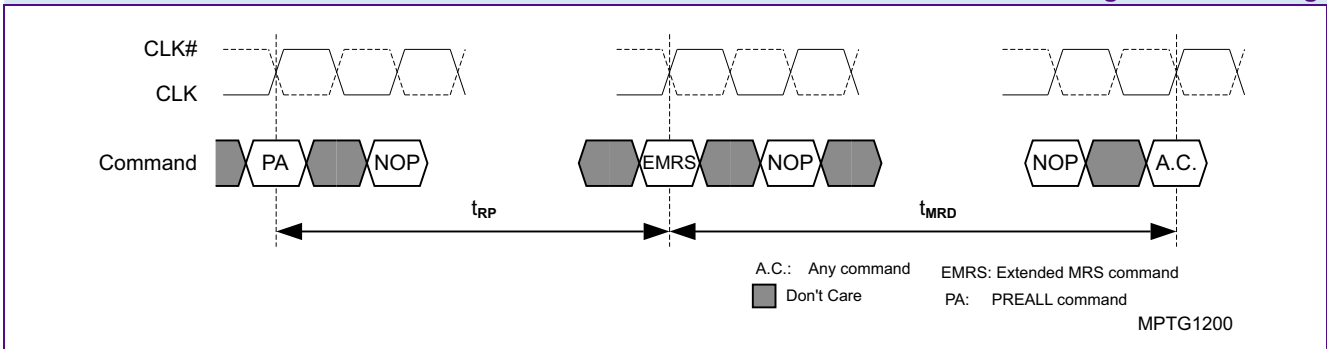


**Notes**

1. This device supports two operation modes: 1-CS mode or 2-CS mode. For detail configurations and mode selection in relation to signals and ballouts. Please refer to **Section 4.2.7** for further details.
2. Default termination values at Power Up.
3. The ODT disable function disables all terminators on the device.
4. If the user activates bits in the extended mode register in an optional field, either the optional field is activated (if option implemented in the device) or no action is taken by the device (if option not implemented).
5. WR (write recovery time for auto precharge) in clock cycles is calculated by dividing  $t_{WR}$  (in ns) and rounding up to the next integer ( $WR[\text{cycles}] = t_{WR}[\text{ns}] / t_{CK}[\text{ns}]$ ). The mode register must be programmed to this value.



**FIGURE 11**  
**Extended Mode Register Set Timing**



### 4.2.1 DLL enable

The DLL must be enabled for normal operation. DLL enable is required during power-up initialization and upon returning to normal operation after having disabled the DLL. (When the device exits self-refresh mode, the DLL is enabled automatically). Anytime the DLL is enabled, 1000 cycles must occur before a READ command can be issued.

### 4.2.2 WR

The WR parameter is programmed using the register bits A4, A5 and A7. This integer parameter defines as a number of clock cycles the Write Recovery time in a Write with Autoprecharge operation.

The following inequality has to be complied with:  $WR \geq t_{WR}$ , where  $t_{WR}$  is defined as number of clock cycles. The high-speed bitmap supports WR from 7 to 13. The mid-range bitmap provides WR cycles from 4 to 11.

### 4.2.3 Termination Rtt

The data termination, Rtt, is used to set the value of the internal termination resistors. The GDDR3 DRAM supports ZQ / 4 and ZQ / 2 termination values. The termination may also be disabled for testing and other purposes. Data -, address - and command - termination are disabled in parallel. The Termination Rtt are controlled independently from the Output Driver Impedance values.

### 4.2.4 Output Driver Impedance

The Output Driver Impedance extended mode register is used to set the value of the data output driver impedance. When the auto calibration is used, the output driver impedance is set nominally to ZQ / 6.

If the Output Driver Impedance is changed to 35, 40 or 45 Ohms the user needs to issue 16 AREF commands separated by  $t_{RFC}$  consecutively to make the change effective. The user must be aware that the Command bus needs to be stable for a time of  $t_{KO}$  after each AREF.

### 4.2.5 Vendor Code and Revision Identification

The Manufacturer Vendor Code is selected by issuing an Extended Mode Register Set command with bit A10 set to 1 and bits A0-A9 and A11 set to the desired value. When the Vendor Code function is enabled the GDDR3 DRAM will provide the

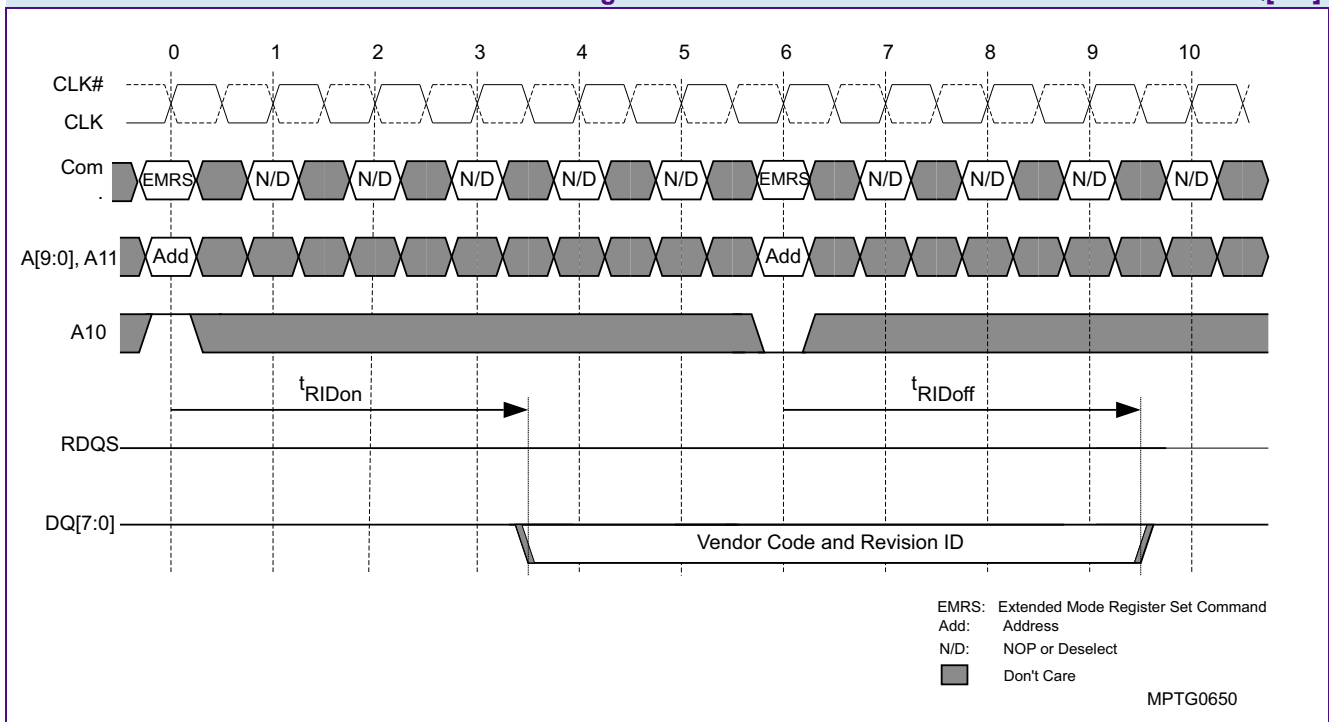


Qimonda vendor code on DQ[3:0] and the revision identification on DQ[7:4]. The code will be driven onto the DQ bus after  $t_{RIDon}$  following the EMRS command that sets A10 to 1. The Vendor Code and Revision ID will be driven on DQ[7:0] until a new EMRS command is issued with A10 set back to 0. After  $t_{RIDoff}$  following the second EMRS command, the data bus is driven back to HIGH. This second EMRS command must be issued before initiating any subsequent operation. Violating this requirement will result in unspecified operation.

**TABLE 11**  
Revision ID and Vendor Code

Revision Identification	Qimonda Vendor Code
DQ[7:4]	DQ[3:0]
0101	0010

**FIGURE 12**  
Timing of Vendor Code and Revision ID Generation on DQ[7:0]



### 4.2.6 Address command termination

The address and command termination is used to set the value of the internal termination resistors. The GDDR3 DRAM supports ZQ / 4, ZQ / 2 and ZQ termination values. The mode register programming overwrites the programming during the chip initialization.



## 4.2.7 Chip Select mode

The GDDR3 DRAM can be internally configured as two 512Mbit (2-CS mode) or one 1Gbit device (1-CS mode). The pins CS1 and A12 are only active in two, resp. 1-CS mode and act either as the chip select for the second rank, or the row-address for the upper 4k-row-address range. If bit A5 from EMRS2 ("Merged Mode") is set to 1 then the 2 operations mode will be inverted.

**TABLE 12****Chip Select Mode based on Merged Mode Settings**

Configuration	EMRS1	EMRS2	Result		Note
	BA2	A5			
	CS Mode	Merge Mode	Signal	Ball	
Config 1	0	0	A12	J2	1)
Config 2	1	0	$\overline{\text{CS1}}$	J3	2)
	0	1	$\overline{\text{CS1}}$	J3	
Config 3	1	1	A12	J3	3)

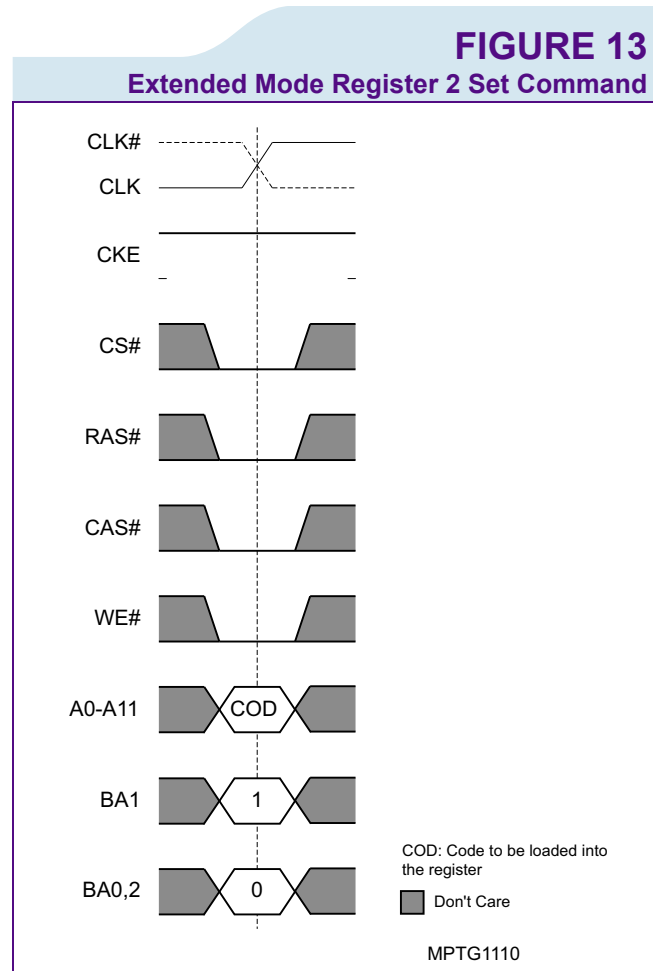
- 1) 1-CS mode and no Ball Merged
- 2) 2-CS mode
- 3) 1-CS mode and Ball Merged



### 4.3 Extended Mode Register 2 Set Command (EMRS2)

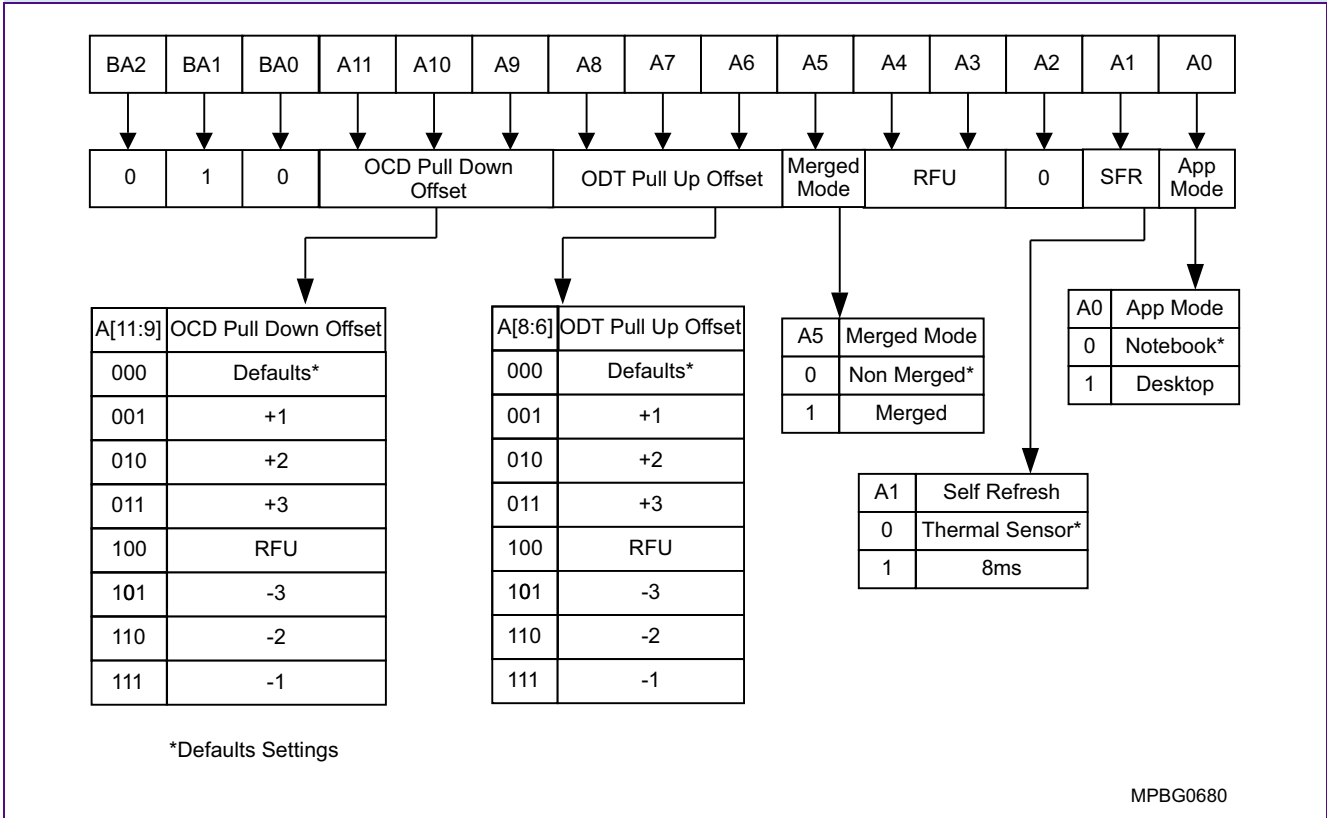
The Extended Mode Register 2 is used to define the active bitmap of the Mode Register (MRS) and the Extended Mode Register (EMRS1). It is used to control OCD/ODT impedance offsets, ballout merged mode, self refresh, and application modes. It can be programmed by performing a normal Mode Register Set operation and setting the BA1 bit to HIGH and BA0, BA2 bits to LOW. All bits defined as RFU in the bitmap are reserved and must be set to LOW.

The Extended Mode Register 2 must be loaded when all banks are idle and no burst are in progress. The controller must wait the specified time  $t_{MRD}$  before initiating any subsequent operation. The timing of the EMRS2 command operation is equivalent to the timing of the MRS command operation.





**FIGURE 14**  
**Extended Mode Register 2 Bitmap**



### 4.3.1 App Mode

The GDDR3 Graphics RAM provides two bitmaps for the Mode Register and the Extended Mode Register respectively. The Bitmaps are shown in the MRS and EMRS chapters.

The Bit0 of the Extended Mode Register 2 defines which one of the two bitmaps is active. There Bit0 set to LOW enables the mid-range bitmap and Bit0 set to HIGH enables the High-Speed bitmap.

### 4.3.2 OCD Pull Down Offset

The 1G GDDR3 add the ability to add an offset to the Output impedance driver set using the bit A[1:0] of the EMRS. A range from -3 to +3 can be chosen using A[11:9]. Each steps correspond to an approximate change of 1 Ohms. The offset will be applied also on Autocal value if selected. The offset will be applied also on Autocal value if selected. With negative offset steps the Driver Strength will be decreased and the Ron will be increased. With positive offset steps the Driver Strength will be increased and Ron will be decreased.



### 4.3.3 ODT Pull Up Offset

The 1G GDDR3 add the ability to add an offset to the ODT set using the bit A[3:2] of the EMRS. A range from -3 to +3 can be chosen using A[8:6]. Each steps correspond to an approximate change of 1.5 Ohms. With negative offset steps the Termination value will be increased. With positive offset steps the Termination value will be decreased.

### 4.3.4 Merged Mode

"Merged Mode" as been added to the EMRS2 in order to merge the node A12/CS1 to a single ball (J-3) of the chip. Default setting has both pins are using two different balls (J-2 and J-3). Please refer to [Section 4.2.7](#) for further details.

### 4.3.5 Self Refresh

Self Refresh is used to control the timing of the refresh operation when the memory is in Self Refresh. When bit A1 is set to 0 then the refresh timing is controlled by the embedded Temperature Sensor. In this mode of operation if the temperature is higher than 100°C then the refresh will happen every 8ms. If the temperature is below 100°C then the refresh will happen every 32 ms. If the A1 is set to 1 then the refresh timing will be independent from the temperature and fixed to 8 ms.

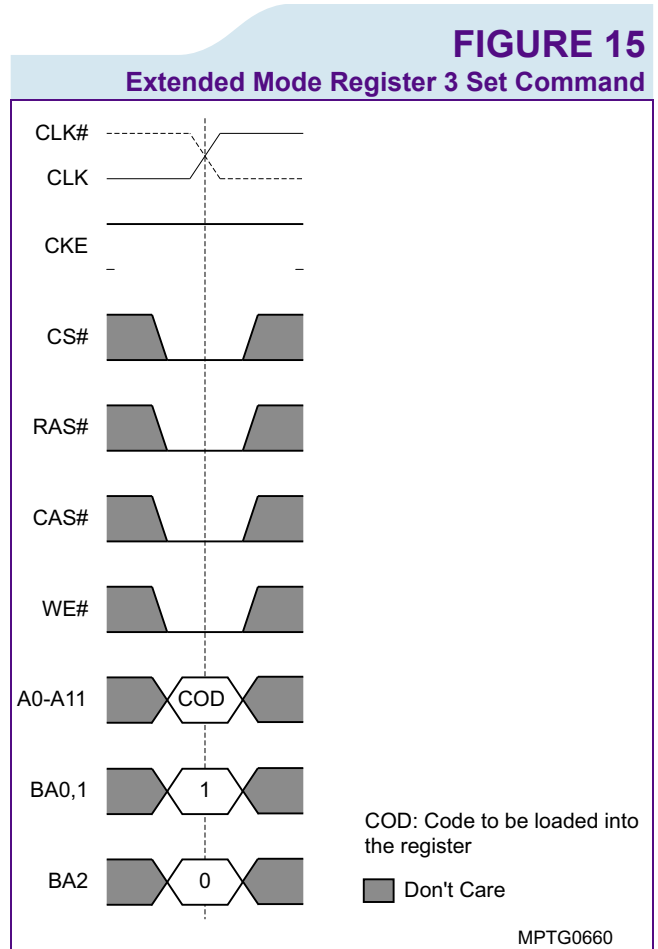


## 4.4 Extended Mode Register 3 Set Command (EMRS3)

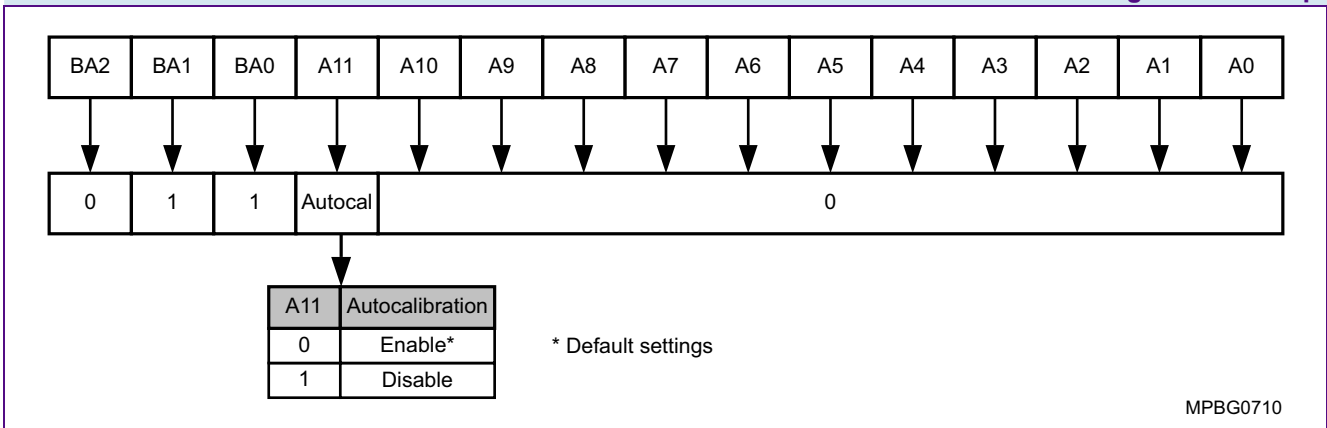
The Extended Mode Register 3 is used for setting the auto-calibration bit. The auto-calibration bit allows for either referencing to the external precision resistor or to fixed set of impedance for drivers and terminations.

The Mode Register can be programmed by performing a normal Mode Register Set operation and setting the BA0, BA1 bits to HIGH and BA2 bit to LOW.

All bits defined as RFU in the bitmap are reserved and must be set to LOW. The Extended Mode Register 3 must be loaded when all banks are idle and no burst are in progress. The controller must wait the specified time  $t_{MRD}$  before initiating any subsequent operation. The timing of the EMRS3 command operation is equivalent to the timing of the MRS command operation.



**FIGURE 16**  
Extended Mode Register 3 Bitmap







## 4.4.1 Autocalibration

Using this setting the ODT and OCD can be disconnected from the autocalibration and become only dependant on the values defined by fuses. The detail operations are described as follows.

(1) Setting EMRS3[11]=1 disables autocalibration for both OCD and ODT. This option will force the behavior of the OCD and ODT to mimic the operation when no ZQ resistor is present. (2) NMOS pulldown offset EMRS2[11:9] and PMOS termination pullup offset EMRS[8:6] will be applied to the results of EMRS3[11], whether autocal results or fused results. (3) The fused results for OCD in (1) will be 40 ohms if "autocal" mode is selected in EMRS1[1:0]. Otherwise the settings for 35,40,45 ohms will be used if selected. (4) The fused results for CA, DQ ODT in (1) will be 60 ohms if ZQ/4 is selected, 120 ohms if ZQ/2 is selected, and will be 240 ohms if ZQ is selected in the field EMRS1[9:8] (CA) and EMRS1[3:2].

The driver and termination impedance settings remain in normal operation when EMRS3[11]=0 (as default).

## 4.5 Voltage Change Sequence

### 4.5.1 Change from 1.8 V to 1.5 V

1. Start normal operation at 1.8 V
2. Close all banks
3. Issue SREFEN
4. Set target frequency
5. Set  $V_{dd}$  to 1.5 V
6. Wait until clock and  $V_{dd}$  are stable
7. Issue SREFEX and wait  $t_{RFC}$
8. Wait  $t_{XSRD}$  DLL locking time before AREF is issued
9. Adjust AC timings to the target frequency
10. Start Normal operations

### 4.5.2 Change from 1.5 V to 1.8 V

1. Start normal operation at 1.5 V
2. Close all banks
3. Adjust AC timings to the target frequency
4. Issue SREFEN
5. Set  $V_{dd}$  to 1.8 V
6. Set target frequency
7. Wait until clock and  $V_{dd}$  are stable
8. Issue SREFEX and wait  $t_{RFC}$
9. Wait  $t_{XSRD}$  DLL locking time before AREF is issued
10. Start Normal operations



## 5 Electrical Characteristics

### 5.1 Absolute Maximum Ratings and Operation Conditions

**TABLE 13**  
Absolute Maximum Ratings

Parameter	Symbol	Rating		Unit
		Min.	Max.	
Power Supply Voltage	$V_{DD}$	-0.5	2.5	V
Power Supply Voltage for Output Buffer	$V_{DDQ}$	-0.5	2.5	V
Input Voltage	$V_{IN}$	-0.5	2.5	V
Output Voltage	$V_{OUT}$	-0.5	2.5	V
Storage Temperature	$T_{STG}$	-55	+150	°C
Junction Temperature	$T_J$	—	+125	°C
Short Circuit Output Current	$I_{OUT}$	—	50	mA

**Attention:** Stresses above the max. values listed here may cause permanent damage to the device. Exposure to absolute maximum rating conditions for extended periods may affect device reliability. Maximum ratings are absolute ratings; exceeding only one of these values may cause irreversible damage to the integrated circuit.

### 5.2 DC Operation Conditions

#### 5.2.1 Recommended Power & DC Operation Conditions

**TABLE 14**  
Power & DC Operation Conditions (0 °C ≤ T<sub>c</sub> ≤ 95 °C)

Parameter	Symbol	Limit Values			Unit	Note
		Min.	Typ.	Max.		
Power Supply Voltage	$V_{DD} / V_{DDQ}$	1.7	1.8	1.9	V	1)2)3)
	$V_{DD} / V_{DDQ}$	1.455	1.5	1.545	V	1)2)4)



HYB18H1G321A2F  
1-Gbit GDDR3 Graphics RAM

Parameter	Symbol	Limit Values			Unit	Note
		Min.	Typ.	Max.		
Reference Voltage	$V_{REF}$	$0.69 \times V_{DDQ}$	—	$0.71 \times V_{DDQ}$	V	5)
Output Low Voltage	$V_{OL(DC)}$	—	—	0.8	V	3)
		—	—	0.62	V	4)
Input leakage current	$I_{IL}$	-5.0	—	+5.0	$\mu A$	6)
CLK Input leakage current	$I_{ILC}$	-5.0	—	+5.0	$\mu A$	
Output leakage current	$I_{OL}$	-5.0	—	+5.0	$\mu A$	6)

- 1) Under all conditions  $V_{DDQ}$  must be less than or equal to  $V_{DD}$
- 2)  $V_{DDQ}$  tracks with  $V_{DD}$ . AC parameters are measured with  $V_{DD}$  and  $V_{DDQ}$  tied together
- 3) for 1.8 V  $V_{DD}/V_{DDQ}$  power supply
- 4) for 1.5 V  $V_{DD}/V_{DDQ}$  power supply
- 5)  $V_{REF}$  is expected to equal 70% of  $V_{DDQ}$  for the transmitting device and to track variations in the DC level of the same. Peak-to-peak noise on  $V_{REF}$  may not exceed  $\pm 2\%$   $V_{REF}$  (DC). Thus, from 70% of  $V_{DDQ}$ ,  $V_{REF}$  is allowed  $\pm 19mV$  for DC error and an additional  $\pm 27mV$  for AC noise
- 6)  $I_{IL}$  and  $I_{OL}$  are measured with ODT disabled

### 5.3 DC & AC Logic Input Levels

**TABLE 15**  
DC & AC Logic Input Levels (0 °C ≤ T<sub>c</sub> ≤ 95 °C)

Parameter	Symbol	Limit Values		Unit	Note
		Min.	Max.		
Input logic high voltage, DC	$V_{IH(DC)}$	$V_{REF} + 0.15$	—	V	1)3)
		$V_{REF} + 0.12$	—	V	2)3)
Input logic low voltage, DC	$V_{IL(DC)}$	—	$V_{REF} - 0.15$	V	1)3)
		—	$V_{REF} - 0.12$	V	2)3)
Input logic high voltage, AC	$V_{IH(AC)}$	$V_{REF} + 0.25$	—	V	1)4)5)
		$V_{REF} + 0.2$	—	V	2)4)5)
Input logic low voltage, AC	$V_{IL(AC)}$	—	$V_{REF} - 0.25$	V	1)4)5)
		—	$V_{REF} - 0.2$	V	2)4)5)
Input logic high, DC, RESET pin	$V_{IHR(DC)}$	$0.65 \times V_{DDQ}$	$V_{DDQ} + 0.3$	V	
Input logic low, DC, RESET pin	$V_{ILR(DC)}$	-0.3	$0.35 \times V_{DDQ}$	V	
Input Logic High, DC, MF pin	$V_{IHMF(DC)}$	$V_{DD}$	$V_{DD} + 0.3$	V	6)
Input Logic Low, DC, MF pin	$V_{ILMF(DC)}$	-0.3	0	V	

- 1) for 1.8 V  $V_{DD}/V_{DDQ}$  power supply
- 2) for 1.5 V  $V_{DD}/V_{DDQ}$  power supply
- 3) The DC values define where the input slew rate requirements are imposed, and the input signal must not violate these levels in order to maintain a valid level.
- 4) Input slew rate = 3 V/ns. If the input slew rate is less than 3 V/ns, input timing may be compromised. All slew rates are measured between  $V_{IL(AC)}$  and  $V_{IH(AC)}$ .



HYB18H1G321A2F  
1-Gbit GDDR3 Graphics RAM

- 5)  $V_{IH}$  overshoot:  $V_{IH}(\max) = V_{DDQ} + 0.5V$  for a pulse width  $\leq 500ps$  and the pulse width cannot be greater than 1/3 of the cycle rate.  $V_{IL}$  undershoot:  $V_{IL}(\min) = 0V$  for a pulse width  $\leq 500ps$  and the pulse width cannot be greater than 1/3 of the cycle rate.
- 6) The MF pin must be hard-wired on board to either  $V_{DD}$  or  $V_{SS}$ .

## 5.4 Differential Clock DC and AC Levels

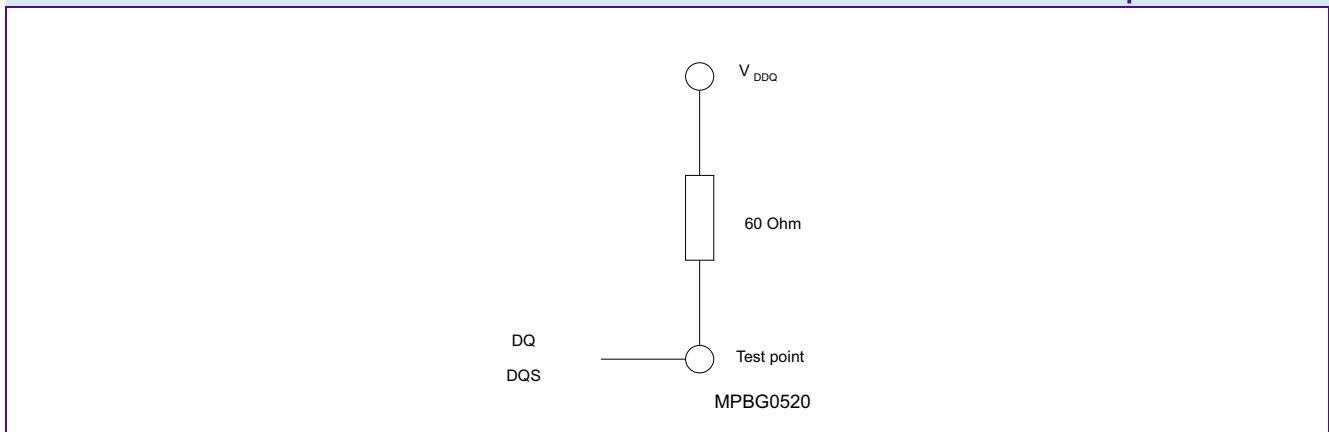
**TABLE 16**  
Differential Clock DC and AC Input conditions ( $0\text{ }^{\circ}\text{C} \leq T_c \leq 95\text{ }^{\circ}\text{C}$ )

Parameter	Symbol	Limit Values		Unit	Note
		Min.	Max.		
Clock Input Mid-Point Voltage, CLK and $\overline{\text{CLK}}$	$V_{MP}(\text{DC})$	$0.7 \times V_{DDQ} - 0.10$	$0.7 \times V_{DDQ} + 0.10$	V	1)
Clock Input Voltage Level, CLK and $\overline{\text{CLK}}$	$V_{IN}(\text{DC})$	0.42	$V_{DDQ} + 0.3$	V	1)2)
		0.35	$V_{DDQ} + 0.3$	V	1)3)
Clock DC Input Differential Voltage, CLK and $\overline{\text{CLK}}$	$V_{ID}(\text{DC})$	0.3	$V_{DDQ}$	V	1)
Clock AC Input Differential Voltage, CLK and $\overline{\text{CLK}}$	$V_{ID}(\text{AC})$	0.5	$V_{DDQ} + 0.5$	V	1)2)4)
		0.4	$V_{DDQ} + 0.5$	V	1)3)4)
AC Differential Crossing Point Input Voltage	$V_{IX}(\text{AC})$	$0.7 \times V_{DDQ} - 0.15$	$0.7 \times V_{DDQ} + 0.15$	V	1)2)5)
		$0.7 \times V_{DDQ} - 0.12$	$0.7 \times V_{DDQ} + 0.12$	V	1)3)5)

- 1) All voltages referenced to  $V_{SS}$ .
- 2) for 1.8 V  $V_{DD}/V_{DDQ}$  power supply
- 3) for 1.5 V  $V_{DD}/V_{DDQ}$  power supply
- 4)  $V_{ID}$  is the magnitude of the difference between the input level on CLK and the input level on  $\overline{\text{CLK}}$ .
- 5) The value of  $V_{IX}$  is expected to equal  $0.7 \times V_{DDQ}$  of the transmitting device and must track variations in the DC level of the same.

## 5.5 Output Test Conditions

**FIGURE 17**  
Output Test Circuit





## 5.6 Pin Capacitances

**TABLE 17**

**Pin Capacitances (VDDQ = 1.8 V, TA = 25°C, f = 1 MHz)**

Parameter	Symbol	Min.	Max.	Unit	Note
Input capacitance: A0-A11,A12, , BA0-2, CKE, $\overline{CS}$ , $\overline{CAS}$ , $\overline{RAS}$ , $\overline{WE}$ , CKE, RES,CLK,CLK	CI,CCK	1.0	2.5	pF	
Input capacitance: DQ0-DQ31, RDQS0-RDQS3, WDQS0-WDQS3, DM0-DM3	CIO	2.0	3.0	pF	

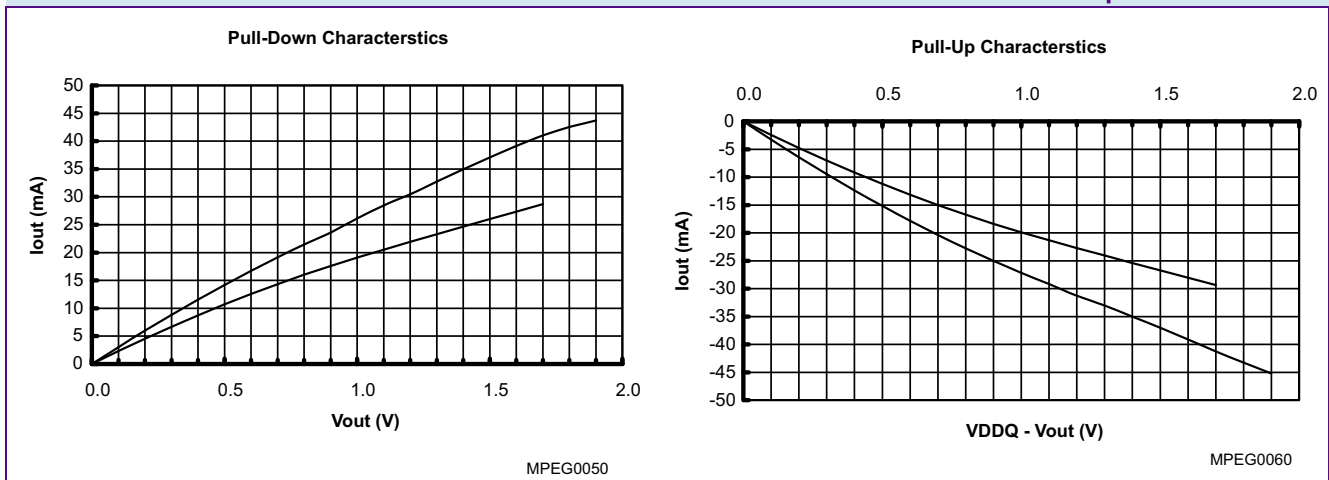
## 5.7 Driver current characteristics

### 5.7.1 Driver IV characteristics at 40 Ohms

**Figure 18** represents the driver Pull-Down and Pull-Up IV characteristics under process, voltage and temperature best and worst case conditions. The actual Driver Pull-Down and Pull-Up current must lie between these two bounding curves. The value of the external ZQ resistor is 240  $\Omega$ , setting the nominal driver output impedance to 40  $\Omega$ .

**FIGURE 18**

**40 Ohm Driver Pull-Down and Pull-Up Characteristics**



**Table 18** lists the numerical values of the minimum and maximum allowed values of the output driver Pull-Down and Pull-Up IV characteristics.

**TABLE 18**  
Programmed Driver IV Characteristics at 40 Ohm

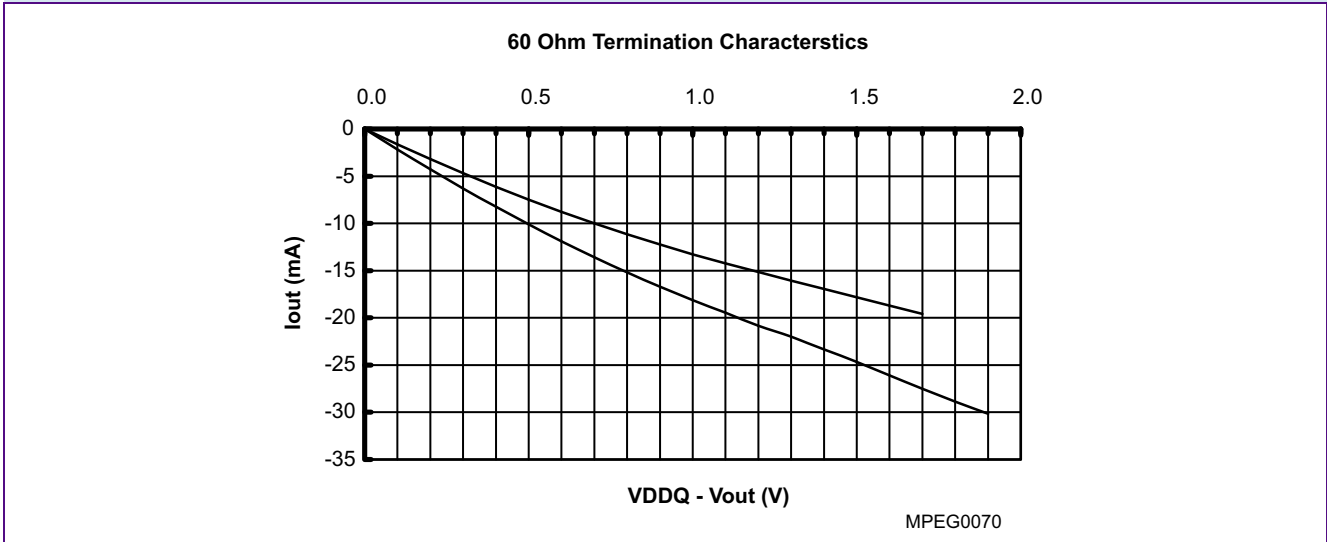
Voltage (V)	Pull-Down Current (mA)		Pull-Up Current (mA)	
	Minimum	Maximum	Minimum	Maximum
0.1	2.32	3.04	-2.44	-3.27
0.2	4.56	5.98	-4.79	-6.42
0.3	6.69	8.82	-7.03	-9.45
0.4	8.74	11.56	-9.18	-12.37
0.5	10.70	14.19	-11.23	-15.17
0.6	12.56	16.72	-13.17	-17.83
0.7	14.34	19.14	-15.01	-20.37
0.8	16.01	21.44	-16.74	-22.78
0.9	17.61	23.61	-18.37	-25.04
1.0	19.11	26.10	-19.90	-27.17
1.1	20.53	28.45	-21.34	-29.17
1.2	21.92	30.45	-22.72	-31.25
1.3	23.29	32.73	-24.07	-33.00
1.4	24.65	34.95	-25.40	-35.00
1.5	26.00	37.10	-26.73	-37.00
1.6	27.35	39.15	-28.06	-39.14
1.7	28.70	41.01	-29.37	-41.25
1.8	30.08	42.53	-30.66	-43.29
1.9	—	43.71	—	-45.23
2.0	—	44.89	—	-47.07

## 5.7.2 Termination IV Characteristic at 60 Ohms

**Figure 19** represents the DQ termination Pull-Up IV characteristic under process, voltage and temperature best and worst case conditions. The actual DQ termination Pull-Up current must lie between these two bounding curves. The value of the external ZQ resistor is 240  $\Omega$ , setting the nominal DQ termination impedance to 60  $\Omega$ . (Extended Mode Register programmed to ZQ/4).



**FIGURE 19**  
60 Ohm Active Termination Characteristic



**Table 19** lists the numerical values of the minimum and maximum allowed values of the output driver termination IV characteristic.

**TABLE 19**  
Programmed Terminator Characteristics at 60 Ohm

Voltage (V)	Terminator Pull-Up Current (mA)		Voltage (V)	Terminator Pull-Up Current (mA)	
	Minimum	Maximum		Minimum	Maximum
0.1	-1.63	-2.18	1.1	-14.23	-19.45
0.2	-3.19	-4.28	1.2	-15.14	-20.83
0.3	-4.69	-6.30	1.3	-16.04	-22.00
0.4	-6.12	-8.25	1.4	-16.94	-23.33
0.5	-7.49	-10.11	1.5	-17.82	-24.67
0.6	-8.78	-11.89	1.6	-18.70	-26.09
0.7	-10.01	-13.58	1.7	-19.58	-27.50
0.8	-11.16	-15.19	1.8	-20.44	-28.86
0.9	-12.25	-16.69	1.9	—	-30.15
1.0	-13.27	-18.11	2.0	—	-31.38

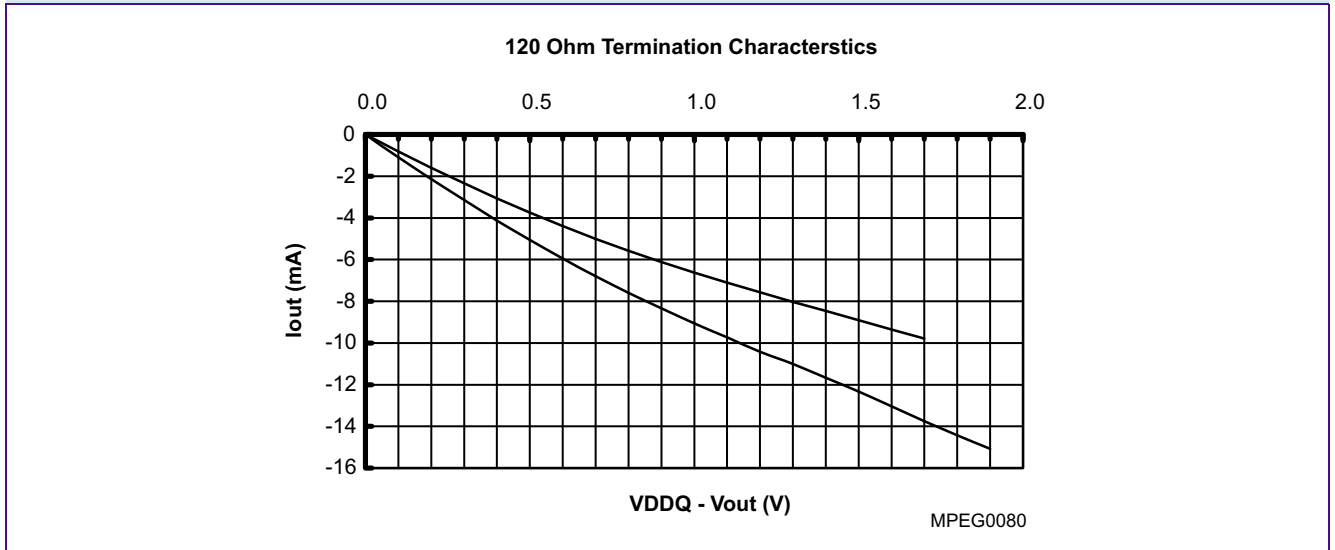


## 5.8 Termination IV Characteristic at 120 Ohms

**Figure 20** represents the DQ or ADD/CMD termination Pull-Up IV characteristic under process, voltage and temperature best and worst case conditions. The actual termination Pull-Up current must lie between these two bounding curves. The value of the external ZQ resistor is 240 Ω, setting the nominal termination impedance to 120 Ω. (Extended Mode Register programmed to ZQ/2 for DQ terminations or CKE = 0 at the RES transition during Power-Up for ADD/CMD terminations).

**FIGURE 20**

**120 Ohm Active Termination Characteristic**



**Table 20** lists the numerical values of the minimum and maximum allowed values of the termination IV characteristic.

**TABLE 20**

**Programmed Terminator Characteristics of 120 Ohm**

Voltage (V)	Terminator Pull-Up Current (mA)		Voltage (V)	Terminator Pull-Up Current (mA)	
	Minimum	Maximum		Minimum	Maximum
0.1	-0.81	-1.09	1.1	-7.11	-9.72
0.2	-1.60	-2.14	1.2	-7.57	-10.42
0.3	-2.34	-3.15	1.3	-8.02	-11.00
0.4	-3.06	-4.12	1.4	-8.47	-11.67
0.5	-3.74	-5.06	1.5	-8.91	-12.33
0.6	-4.39	-5.94	1.6	-9.35	-13.05
0.7	-5.00	-6.79	1.7	-9.79	-13.75
0.8	-5.58	-7.59	1.8	-10.22	-14.43
0.9	-6.12	-8.35	1.9	—	-15.08
1.0	-6.63	-9.06	2.0	—	-15.69



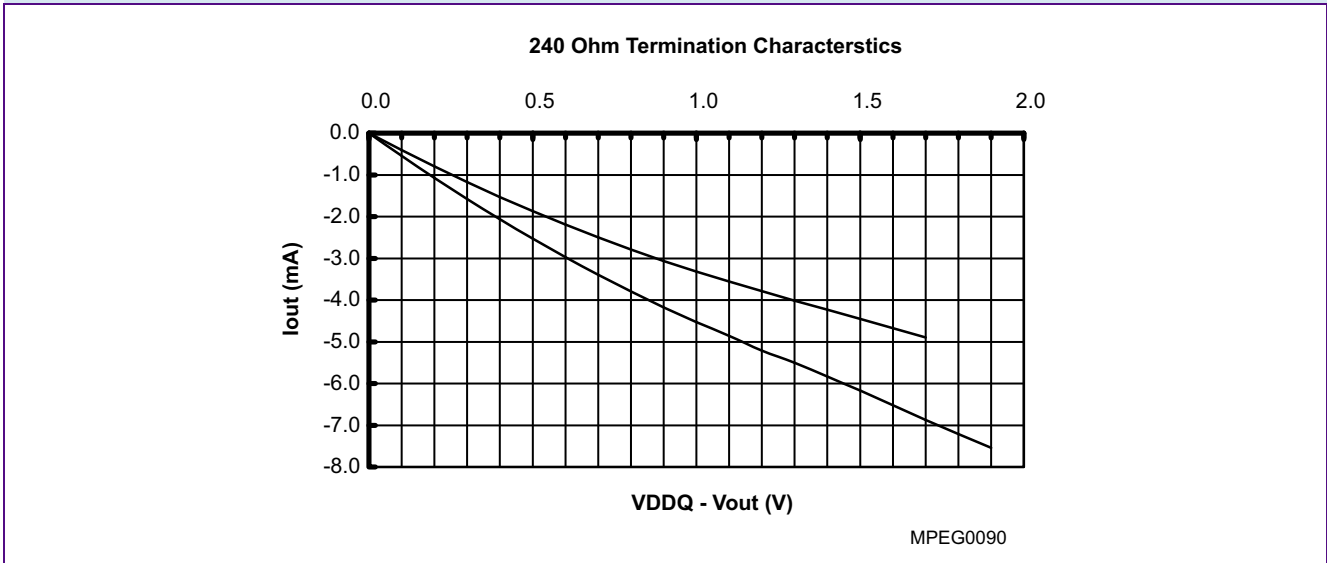


## 5.9 Termination IV Characteristic at 240 Ohms

**Figure 21** represents the ADD/CMD termination Pull-Up IV characteristic under process, voltage and temperature best and worst case conditions. The actual ADD/CMD termination Pull-Up current must lie between these two bounding curves. The value of the external ZQ resistor is 240 Ω, setting the nominal termination impedance to 240 Ω. (CKE = 1at the RES transition during Power-Up for ADD/CMD terminations).

**FIGURE 21**

**240 Ohm Active Termination Characteristic**



**Table 21** lists the numerical values of the minimum and maximum allowed values of the ADD/CMD termination IV characteristic.

**TABLE 21**

**Programmed Terminator Characteristics at 240 Ohm**

Voltage (V)	Terminator Pull-Up Current (mA)		Voltage (V)	Terminator Pull-Up Current (mA)	
	Minimum	Maximum		Minimum	Maximum
0.1	-0.41	-0.55	1.1	-3.56	-4.86
0.2	-0.80	-1.07	1.2	-3.79	-5.21
0.3	-1.17	-1.58	1.3	-4.01	-5.50
0.4	-1.53	-2.06	1.4	-4.23	-5.83
0.5	-1.87	-2.53	1.5	-4.46	-6.17
0.6	-2.20	-2.97	1.6	-4.68	-6.52
0.7	-2.50	-3.40	1.7	-4.90	-6.88
0.8	-2.79	-3.80	1.8	-5.11	-7.21
0.9	-3.06	-4.17	1.9	—	-7.54
1.0	-3.32	-4.53	2.0	—	-7.85



## 5.10 Operating Currents

### 5.10.1 Operating Current Ratings for HYB18H1G321A2F

**TABLE 22**  
Operating Current Ratings ( 0 °C ≤ T<sub>c</sub> ≤ 95 °C)

Parameter	Symbol	Limit Values			Unit	Note	
		-8	-10	-14			
		Typ.	Typ.	Typ.			
Operating Current	$I_{DD0}$	TBD	TBD	TBD	mA	1)2)3)	
	$I_{DD1}$	TBD	TBD	TBD	mA	1)2)3)	
Precharge Power-Down Standby Current	$I_{DD2P}$	TBD	TBD	TBD	mA	1)2)3)	
Active Power-Down Standby Current	$I_{DD3P}$	TBD	TBD	TBD	μA	1)2)3)	
Active Standby Current	$I_{DD3N}$	TBD	TBD	TBD	mA	1)2)3)	
Operating Current Burst Read	$I_{DD4R}$	TBD	TBD	TBD	mA	1)2)3)	
Operating Current Burst Write	$I_{DD4W}$	TBD	TBD	TBD	mA	1)2)3)	
Auto-Refresh Current ( $t_{RC}=\min(t_{RFC})$ )	$I_{DD5B}$	TBD	TBD	TBD	mA	1)2)3)	
Self Refresh Current	$I_{DD6}$	TBD	TBD	TBD	mA	1)2)3)4)	
Operating Current	1-CS	$I_{DD7}$	TBD	TBD	TBD	mA	1)2)3)
	2-CS		TBD	TBD	TBD	mA	1)2)3)

- 1) IDD specifications are tested after the device is properly initialized.
- 2) Input slew rate = 3V/ns.
- 3) Measured with Output open and On Die termination off.
- 4) Enables on-chip refresh and address counter.



## 5.11 Operating Current Measurement Conditions

**TABLE 23**  
**Operating Current Measurement Conditions**

Symbol	Parameter/Condition
$I_{DD0}$	Operating Current - One bank, Activate - Precharge $t_{CK}=\min(t_{CK}), t_{RC}=\min(t_{RC})$ Databus inputs are SWITCHING; Address and control inputs are SWITCHING, $\overline{CS}$ = HIGH between valid commands.
$I_{DD1}$	Operating Current - One bank, Activate - Read - Precharge One bank is accessed with $t_{CK}=\min(t_{CK}), t_{RC}=\min(t_{RC}), CL = CL(\min)$ , Address and control inputs are SWITCHING; $\overline{CS}$ = HIGH between valid commands. $I_{out}=0$ mA
$I_{DD2P}$	Precharge Power-Down Standby Current All banks idle, power-down mode, CKE is LOW, $t_{CK}=\min(t_{CK})$ , Data bus inputs are STABLE (HIGH).
$I_{DD3P}$	Active Power-Down Standby Current One bank active, CKE is LOW, Address and control inputs are STABLE (HIGH); Data bus inputs are STABLE (HIGH); standard active power-down mode.
$I_{DD3N}$	Active Standby Current One bank active, $\overline{CS}$ is HIGH, CKE is HIGH, $t_{RAS}=t_{RAS,max}, t_{CK}=\min(t_{CK})$ ; Address and control inputs are SWITCHING; Data bus inputs are SWITCHING.
$I_{DD4R}$	Operating Current - Burst Read One bank active; Continuous read bursts, $CL = CL(\min); t_{CK}=\min(t_{CK}); t_{RAS}=t_{RAS,max}$ ; Address and control inputs are SWITCHING; $I_{out} = 0$ mA.
$I_{DD4W}$	Operating Current - Burst Write One bank active; Continuous write bursts; $t_{CK}=\min(t_{CK})$ ; Address and control inputs are SWITCHING; Data bus inputs are SWITCHING.
$I_{DD5B}$	Burst Auto Refresh Current Refresh command at $t_{RFC}=\min(t_{RFC}); t_{CK}=\min(t_{CK})$ ; CKE is HIGH, $\overline{CS}$ is HIGH between all valid commands; Other command and address inputs are SWITCHING; Data bus inputs are SWITCHING.
$I_{DD6}$	Self Refresh Current $CKE \leq \max(V_{IL})$ , external clock off, CK and $\overline{CK}$ LOW; Address and control inputs are STABLE (HIGH); Data Bus inputs are STABLE (HIGH).
$I_{DD7}$	Operating Bank Interleave Read Current 1. 1-CS Mode: All banks interleaving with $CL = CL(\min); t_{RCD} = t_{RCDRD}(\min); t_{RRD} = t_{RRD}(\min); I_{out}=0$ mA; Address and control inputs are STABLE (HIGH) during DESELECT; Data bus inputs are SWITCHING.

### Notes

- $0\text{ }^{\circ}\text{C} \leq T_c \leq 95\text{ }^{\circ}\text{C}$
- Data Bus consists of DQ, DM, WDQS.
- Definitions for IDD:  
 LOW is defined as  $V_{IN} = 0.4 \times V_{DDQ}$ ; HIGH is defined as  $V_{IN} = V_{DDQ}$ ;  
 STABLE is defined as inputs are stable at a HIGH level.  
 SWITCHING is defined as inputs are changing between HIGH and LOW every clock cycle for address and control signals, and inputs changing 50% of each data transfer for DQ signals.



## 5.12 AC Timings for HYB18H1G321A2F

**TABLE 24**  
Timing Parameters for HYB18H1G321A2F

Parameter		Symbol	-8		-10		-14		Unit	Note
			Min.	Max.	Min.	Max.	Min.	Max.		
<b>System Frequency</b>	CL = 15	$f_{CK15}$	250	1200	—	—	—	—	MHz	1)
	CL = 12	$f_{CK12}$	250	1000	250	1000	—	—	MHz	1)
	CL = 11	$f_{CK11}$	250	900	250	900	—	—	MHz	1)
	CL = 10	$f_{CK10}$	250	850	250	850	250	700	MHz	1)
	CL = 9	$f_{CK9}$	250	750	250	750	250	650	MHz	1)
	CL = 8	$f_{CK8}$	250	650	250	650	250	550	MHz	1)
	CL = 7	$f_{CK7}$	250	600	250	600	250	500	MHz	1)
Clock cycle to cycle period jitter		$t_{JIT(cc)}$	0.06		0.06		0.06		$t_{CK}$	2)3)
Clock high level width		$t_{CH}$	0.45	0.55	0.45	0.55	0.45	0.55	$t_{CK}$	2)3)
Clock low level width		$t_{CL}$	0.45	0.55	0.45	0.55	0.45	0.55	$t_{CK}$	2)3)
Minimum clock half period		$t_{HP}$	0.45	—	0.45	—	0.45	—	$t_{CK}$	2)
<b>Command and Address Setup and Hold Timing</b>										
Address/Command input setup time		$t_{IS}$	0.22	—	0.24	—	0.35	—	ns	4)5)
Address/Command input hold time		$t_{IH}$	0.22	—	0.24	—	0.35	—	ns	4)5)
Address/Command input pulse width		$t_{IPW}$	0.7	—	0.7	—	0.7	—	$t_{CK}$	
<b>Mode Register Set Timing</b>										
Mode Register Set cycle time		$t_{MRD}$	6	—	6	—	6	—	$t_{CK}$	6)7)
Mode Register Set to READ timing		$t_{MRDR}$	12	—	12	—	12	—	$t_{CK}$	6)7)
<b>Row Timing</b>										
Row cycle time		$t_{RC}$	44	—	39	—	34	—	$t_{CK}$	
Row active time		$t_{RAS}$	28	—	25	—	22	—	$t_{CK}$	8)
ACT(a) to ACT(b) command period		$t_{RRD}$	10	—	9	—	7	—	$t_{CK}$	
ACT(a) to ACT(b) command period (different rank)		$t_{RRD\_RR}$	1	—	1	—	1	—	$t_{CK}$	9)
Row precharge time		$t_{RP}$	16	—	14	—	12	—	$t_{CK}$	
Row to Column delay time for Reads		$t_{RCDRD}$	15	—	13	—	11	—	$t_{CK}$	
Row to Column delaytime for Writes		$t_{RCDWR}$	Min: $\max[(t_{RCDRD}(\text{min}) - (WL + 1)); 2]$ Max: —						$t_{CK}$	
Four Active Windows		$t_{FAW}$	42	—	36	—	35	—	$t_{CK}$	10)
<b>Column Timing</b>										
CAS(a) to CAS(b) command period		$t_{CCD}$	2	—	2	—	2	—	$t_{CK}$	10)
Write to Read command delay		$t_{WTR}$	8	—	7	—	6	—	$t_{CK}$	11)
Write to Read command delay (different rank)		$t_{WTR\_RR}$	BL/2 - 1	—	BL/2 - 1	—	BL/2 - 1	—	$t_{CK}$	9)12)
Write to Write command delay (different rank)		$t_{WTW\_RR}$	BL/2	—	BL/2	—	BL/2	—	$t_{CK}$	9)



HYB18H1G321A2F  
1-Gbit GDDR3 Graphics RAM

Parameter	Symbol	-8		-10		-14		Unit	Note
		Min.	Max.	Min.	Max.	Min.	Max.		
Read to Write command delay	$t_{RTW}$	Min: (CL + BL/2 + 2 - WL) Max: —						$t_{CK}$	13)
Read to Read command delay (different rank)	$t_{RTR\_RR}$	2	—	2	—	2	—	$t_{CK}$	9)
<b>Write Cycle Timing Parameters</b>									
Write command to first WDQS latching transition	$t_{DQSS}$	WL- 0,25	WL+ 0,25	WL- 0,25	WL+ 0,25	WL- 0,25	WL+ 0,25	$t_{CK}$	
Data-in and Data Mask to WDQS setup time	$t_{DS}$	0.12	—	0.14	—	0.18	—	ns	4)14)
Data-in and Data Mask to WDQS hold time	$t_{DH}$	0.12	—	0.14	—	0.18	—	ns	4)14)
Data-in and DM input pulse width (each input)	$t_{DIPW}$	0.4	—	0.4	—	0.4	—	$t_{CK}$	2)
DQS input low pulse width	$t_{DQSL}$	0.4	—	0.4	—	0.4	—	$t_{CK}$	
DQS input high pulse width	$t_{DQSH}$	0.4	—	0.4	—	0.4	—	$t_{CK}$	
DQS Write preamble time	$t_{WPRE}$	0.75	1.25	0.75	1.25	0.75	1.25	$t_{CK}$	
DQS Write postamble time	$t_{WPST}$	0.75	1.25	0.75	1.25	0.75	1.25	$t_{CK}$	
Write recovery time	$t_{WR}$	15	—	13	—	10	—	$t_{CK}$	11)
<b>Read Cycle Timing Parameters for Data and Data Strobe</b>									
Data access time from clock	$t_{AC}$	-0.2	0.2	-0.21	0.21	-0.25	0.25	ns	
Read preamble	$t_{RPRE}$	0.75	1.25	0.75	1.25	0.75	1.25	$t_{CK}$	2)
Read postamble	$t_{RPST}$	0.75	1.25	0.75	1.25	0.75	1.25	$t_{CK}$	
Data-out high impedance time from CLK	$t_{HZ}$	$t_{ACmin}$	$t_{ACmax}$	$t_{ACmin}$	$t_{ACmax}$	$t_{ACmin}$	$t_{ACmax}$	ns	
Data-out low impedance time from CLK	$t_{LZ}$	$t_{ACmin}$	$t_{ACmax}$	$t_{ACmin}$	$t_{ACmax}$	$t_{ACmin}$	$t_{ACmax}$	ns	
DQS edge to clock edge skew	$t_{DQSCK}$	-0.2	0.2	-0.21	0.21	-0.25	0.25	ns	
DQS edge to output data edge skew	$t_{DQSQ}$	—	0.11	—	0.12	—	0.16	ns	4)
Data hold skew factor	$t_{QHS}$	—	0.11	—	0.12	—	0.16	ns	
Data output hold time from DQS	$t_{QH}$	$t_{HP} - t_{QHS}$						ns	
<b>Refresh/Power Down Timing for Data and Data Strobe</b>									
Refresh period (8192 cycles)	$t_{REF}$	—	32	—	32	—	32	ms	
Average periodic auto refresh interval	$t_{REFI}$	3.9		3.9		3.9		$\mu$ s	
Delay from AREF to next ACT/ AREF	$t_{RFC}$	52	—	52	—	59	—	ns	
Self refresh exit time	$t_{XSRD}$	1000	—	1000	—	1000	—	$t_{CK}$	
Self refresh exit followed non Read command	$t_{XSNR}$	100	—	100	—	100	—	$t_{CK}$	15)
Power Down exit time	$t_{XPN}$	9	—	7	—	6	—	$t_{CK}$	
<b>Other Timing Parameters</b>									
RES to CKE setup timing	$t_{ATS}$	10	—	10	—	10	—	ns	
RES to CKE hold timing	$t_{ATH}$	10	—	10	—	10	—	ns	
Termination update Keep Out timing	$t_{KO}$	10	—	10	—	10	—	ns	
Rev, ID EMRS to DQ on timing	$t_{RIDon}$	—	20	—	20	—	20	ns	
Rev, ID EMRS to DQ off timing	$t_{RIDoff}$	—	20	—	20	—	20	ns	

- 1)  $f_{CK}(min), f_{CK}(max)$  for DLL on mode
- 2)  $t_{HP}$  is the lesser of  $t_{CL}$  minimum actually applied to the device CLK, bCLK inputs.
- 3) CLK and bCLK input slew rate must be greater than 3 V/ns
- 4) The input reference level for signals other than CLK and bCLK is  $V_{REF}$

HYB18H1G321A2F  
1-Gbit GDDR3 Graphics RAM

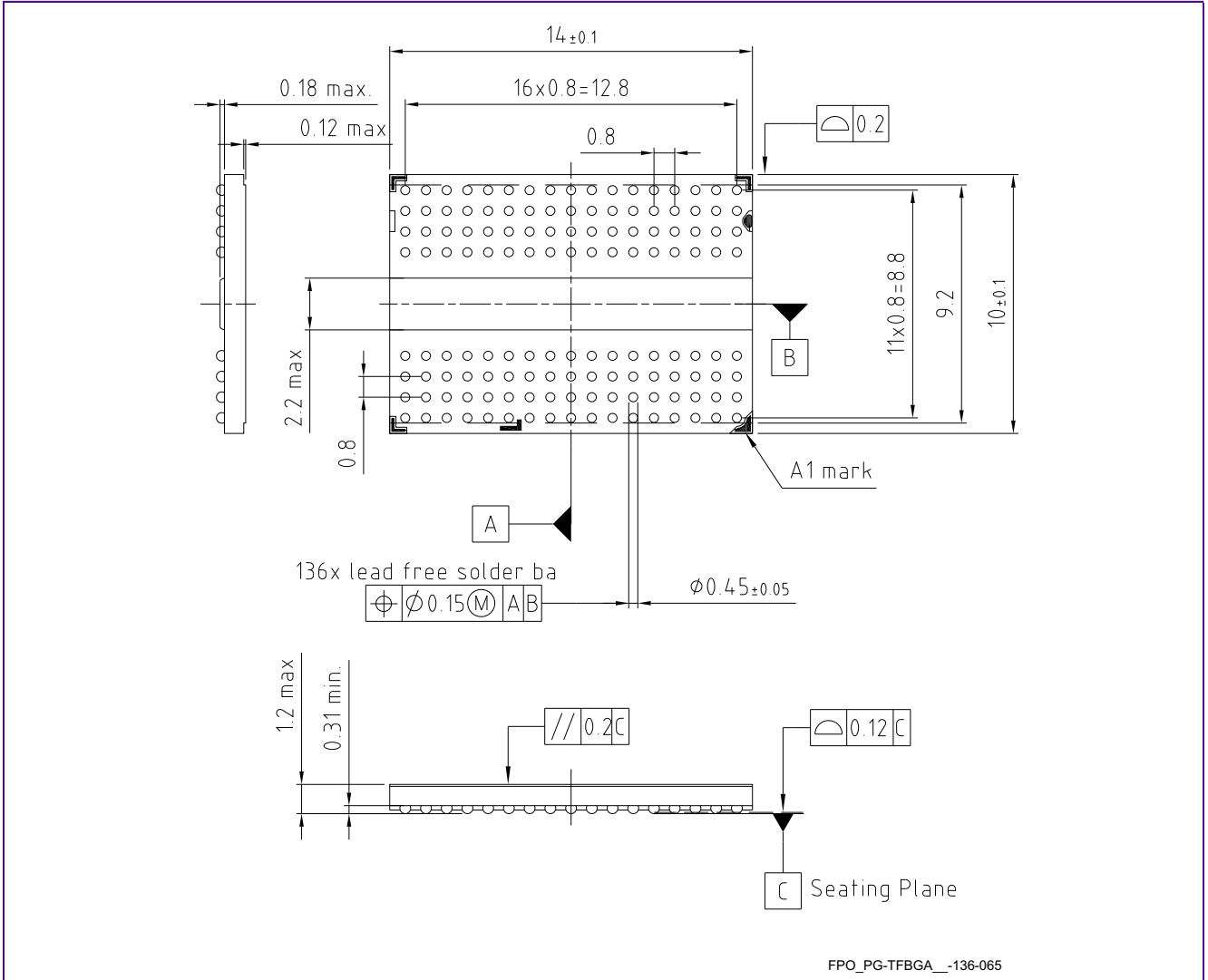
- 5) Command/Address input slew rate = 3 V/ns. If the slew rate is less than 3 V/ns, timing is no longer referenced to the midpoint but to the  $V_{il(AC)}$  maximum and  $V_{ih(AC)}$  minimum points
- 6)  $t_{MRD}$  is defined from MRS to any other command then READ.
- 7) This value of  $t_{MRD}$  applies only to the case where the DLL reset bit is not activated.
- 8)  $t_{RAS,max}$  is  $8 * t_{REF}$ .
- 9) The parameter is defined for commands issued to rank m following rank n where m different than n. For all other type of access, standard timing parameters do apply.
- 10) WTR and  $t_{WR}$  start at the first rising edge of CLK after the last valid (failing) WDQS edge of the slowest WDQS edge.
- 11) Please round up  $t_{RTW}$  to the next integer of  $t_{CK}$
- 12)  $t_{WTR,RR}$  parameter is operated under the conditions that  $CL \geq WL + 3$  (for BL=4) and  $CL \geq WL + 5$  (for BL=8)
- 13) The parameter is defined per byte.
- 14) DQ and DM input slew rate must not deviate from WDQS by more than 10 percent. If the DQ/DM/WDQS slew rate is less than 3 V/ns, timing is no longer referenced to the midpoint but to the  $V_{il(AC)}$  maximum and  $V_{ih(AC)}$  minimum points
- 15) Autocalibration must be turned off to use fixed impedance values



## 6 Package

### 6.1 Package Outline

**FIGURE 22**  
Package Outline PG-TFBGA-136-065



Note: The package is conforming with JEDEC MO-207i, VAR DR-z.



## 6.2 Package Thermal Characteristics

**TABLE 25**  
PG-TFBGA-136 Package Thermal Resistances

JEDEC Board	Theta <sub>jA</sub>						Theta <sub>jB</sub>	Theta <sub>jC</sub>
	1s0p			2s2p				
Air Flow	0 m/s	1 m/s	3 m/s	0 m/s	1 m/s	3 m/s	-	-
K/W	40	32	27	22	19	17	5	2

### Notes

1. *Theta<sub>jA</sub>*: Junction to Ambient thermal resistance. The values have been obtained by simulation using the conditions stated in the JEDEC JESD-51 standard.
2. *Theta<sub>jB</sub>*: Junction to Board thermal resistance. The value has been obtained by simulation.
3. *Theta<sub>jC</sub>*: Junction to Case thermal resistance. The value has been obtained by simulation.





# List of Illustrations

Figure 1	Ballout 1-Gbit GDDR3 Graphics RAM in 1-CS mode in non Merged Mode(Top View; MF = Low) . . . . .	6
Figure 2	Ballout 1-Gbit GDDR3 Graphics RAM in 2-CS mode in non Merged Mode(Top View; MF = Low) . . . . .	7
Figure 3	Ballout 1Gbit GDDR3 Graphics RAM in Merged Mode . . . . .	8
Figure 4	Mode Register Set Command . . . . .	19
Figure 5	Mode Register Bitmap for Mid-Range-Speed Application . . . . .	20
Figure 6	Mode Register Bitmap for High-Speed Application. . . . .	20
Figure 7	Mode Register Set Timing . . . . .	21
Figure 8	Extended Mode Register Set Command . . . . .	23
Figure 9	Extended Mode Register Bitmap for Mid-Range-Speed Application . . . . .	24
Figure 10	Extended Mode Register Bitmap for High-Speed Application . . . . .	25
Figure 11	Extended Mode Register Set Timing . . . . .	26
Figure 12	Timing of Vendor Code and Revision ID Generation on DQ[7:0] . . . . .	27
Figure 13	Extended Mode Register 2 Set Command . . . . .	29
Figure 14	Extended Mode Register 2 Bitmap . . . . .	30
Figure 15	Extended Mode Register 3 Set Command . . . . .	32
Figure 16	Extended Mode Register 3 Bitmap . . . . .	32
Figure 17	Output Test Circuit . . . . .	36
Figure 18	40 Ohm Driver Pull-Down and Pull-Up Characteristics. . . . .	37
Figure 19	60 Ohm Active Termination Characteristic . . . . .	39
Figure 20	120 Ohm Active Termination Characteristic . . . . .	40
Figure 21	240 Ohm Active Termination Characteristic . . . . .	41
Figure 22	Package Outline PG-TFBGA-136-065 . . . . .	47



# List of Tables

Table 1	Ordering Information . . . . .	4
Table 2	Ball Description . . . . .	9
Table 3	Ball Assignment with Mirror . . . . .	11
Table 4	Command Overview for 1-CS mode . . . . .	12
Table 5	Command Overview for 2-CS mode . . . . .	13
Table 6	Function Truth Table I . . . . .	15
Table 7	Function Truth Table II (CKE Table) . . . . .	16
Table 8	Boundary Scan Exit Order . . . . .	17
Table 9	Scan Pin Description . . . . .	18
Table 10	Burst Definition . . . . .	21
Table 11	Revision ID and Vendor Code . . . . .	27
Table 12	Chip Select Mode based on Merged Mode Settings . . . . .	28
Table 13	Absolute Maximum Ratings . . . . .	34
Table 14	Power & DC Operation Conditions ( $0\text{ }^{\circ}\text{C} \leq T_c \leq 95\text{ }^{\circ}\text{C}$ ) . . . . .	34
Table 15	DC & AC Logic Input Levels ( $0\text{ }^{\circ}\text{C} \leq T_c \leq 95\text{ }^{\circ}\text{C}$ ) . . . . .	35
Table 16	Differential Clock DC and AC Input conditions ( $0\text{ }^{\circ}\text{C} \leq T_c \leq 95\text{ }^{\circ}\text{C}$ ) . . . . .	36
Table 17	Pin Capacitances (VDDQ = 1.8 V, TA = 25°C, f = 1 MHz) . . . . .	37
Table 18	Programmed Driver IV Characteristics at 40 Ohm . . . . .	38
Table 19	Programmed Terminator Characteristics at 60 Ohm . . . . .	39
Table 20	Programmed Terminator Characteristics of 120 Ohm . . . . .	40
Table 21	Programmed Terminator Characteristics at 240 Ohm . . . . .	41
Table 22	Operating Current Ratings ( $0\text{ }^{\circ}\text{C} \leq T_c \leq 95\text{ }^{\circ}\text{C}$ ) . . . . .	42
Table 23	Operating Current Measurement Conditions . . . . .	43
Table 24	Timing Parameters for HYB18H1G321A2F . . . . .	44
Table 25	PG-TFBGA-136 Package Thermal Resistances . . . . .	48



# Contents

<b>1</b>	<b>Overview</b> .....	<b>3</b>
1.1	Features .....	3
1.2	Description .....	5
<b>2</b>	<b>Configuration</b> .....	<b>6</b>
2.1	Ball Definition and Description .....	9
2.2	Mirror Function .....	11
2.3	Commands .....	12
2.3.1	Command Table .....	12
2.4	Truth Tables .....	15
2.4.1	Function Truth Table for more than one Activated Bank .....	15
2.5	Function Truth Table for CKE .....	16
<b>3</b>	<b>Boundary Scan</b> .....	<b>17</b>
3.1	General Description .....	17
3.2	Disabling the scan feature .....	17
<b>4</b>	<b>Functional Description</b> .....	<b>19</b>
4.1	Mode Register Set Command (MRS) .....	19
4.1.1	Burst length .....	21
4.1.2	Burst type .....	21
4.1.3	CAS Latency .....	22
4.1.4	Write Latency .....	22
4.1.5	Test mode .....	22
4.1.6	DLL Reset .....	22
4.2	Extended Mode Register Set Command (EMRS1) .....	23
4.2.1	DLL enable .....	26
4.2.2	WR .....	26
4.2.3	Termination Rtt .....	26
4.2.4	Output Driver Impedance .....	26
4.2.5	Vendor Code and Revision Identification .....	26
4.2.6	Address command termination .....	27
4.2.7	Chip Select mode .....	28
4.3	Extended Mode Register 2 Set Command (EMRS2) .....	29
4.3.1	App Mode .....	30
4.3.2	OCD Pull Down Offset .....	30
4.3.3	ODT Pull Up Offset .....	31
4.3.4	Merged Mode .....	31
4.3.5	Self Refresh .....	31
4.4	Extended Mode Register 3 Set Command (EMRS3) .....	32
4.4.1	Autocalibration .....	33
4.5	Voltage Change Sequence .....	33
4.5.1	Change from 1.8 V to 1.5 V .....	33
4.5.2	Change from 1.5 V to 1.8 V .....	33
<b>5</b>	<b>Electrical Characteristics</b> .....	<b>34</b>
5.1	Absolute Maximum Ratings and Operation Conditions .....	34
5.2	DC Operation Conditions .....	34
5.2.1	Recommended Power & DC Operation Conditions .....	34
5.3	DC & AC Logic Input Levels .....	35
5.4	Differential Clock DC and AC Levels .....	36
5.5	Output Test Conditions .....	36



**HYB18H1G321A2F**  
**1-Gbit GDDR3 Graphics RAM**

5.6	Pin Capacitances .....	37
5.7	Driver current characteristics .....	37
5.7.1	Driver IV characteristics at 40 Ohms .....	37
5.7.2	Termination IV Characteristic at 60 Ohms .....	38
5.8	Termination IV Characteristic at 120 Ohms .....	40
5.9	Termination IV Characteristic at 240 Ohms .....	41
5.10	Operating Currents .....	42
5.10.1	Operating Current Ratings for HYB18H1G321A2F .....	42
5.11	Operating Current Measurement Conditions .....	43
5.12	AC Timings for HYB18H1G321A2F .....	44
<b>6</b>	<b>Package</b> .....	<b>47</b>
6.1	Package Outline .....	47
6.2	Package Thermal Characteristics .....	48

**Edition 2008-10**  
**Published by Qimonda AG**  
**Gustav-Heinemann-Ring 212**  
**D-81739 München, Germany**  
**© Qimonda AG 2008.**  
**All Rights Reserved.**

#### **Legal Disclaimer**

THE INFORMATION GIVEN IN THIS INTERNET DATA SHEET SHALL IN NO EVENT BE REGARDED AS A GUARANTEE OF CONDITIONS OR CHARACTERISTICS. WITH RESPECT TO ANY EXAMPLES OR HINTS GIVEN HEREIN, ANY TYPICAL VALUES STATED HEREIN AND/OR ANY INFORMATION REGARDING THE APPLICATION OF THE DEVICE, QIMONDA HEREBY DISCLAIMS ANY AND ALL WARRANTIES AND LIABILITIES OF ANY KIND, INCLUDING WITHOUT LIMITATION WARRANTIES OF NON-INFRINGEMENT OF INTELLECTUAL PROPERTY RIGHTS OF ANY THIRD PARTY.

#### **Information**

For further information on technology, delivery terms and conditions and prices please contact your nearest Qimonda Office.

#### **Warnings**

Due to technical requirements components may contain dangerous substances. For information on the types in question please contact your nearest Qimonda Office.

Under no circumstances may the Qimonda product as referred to in this Internet Data Sheet be used in

1. Any applications that are intended for military usage (including but not limited to weaponry), or
2. Any applications, devices or systems which are safety critical or serve the purpose of supporting, maintaining, sustaining or protecting human life (such applications, devices and systems collectively referred to as "Critical Systems"), if
  - a) A failure of the Qimonda product can reasonable be expected to - directly or indirectly -
    - (i) Have a detrimental effect on such Critical Systems in terms of reliability, effectiveness or safety; or
    - (ii) Cause the failure of such Critical Systems; or
  - b) A failure or malfunction of such Critical Systems can reasonably be expected to - directly or indirectly -
    - (i) Endanger the health or the life of the user of such Critical Systems or any other person; or
    - (ii) Otherwise cause material damages (including but not limited to death, bodily injury or significant damages to property, whether tangible or intangible).