

ASAP Cordsets For High Speed Serial Data



100BASE-T Cordset With 4 Pin Series 800 Connector

Upgrade commercial high speed serial interconnects to mil spec performance. Glenair's ASAP "Mighty Mouse" cordsets are available for 100BASE-T, Gigabit Ethernet, IEEE 1394 and USB 2.0 applications.

These cordsets combine aerospace-grade data cables with Series 80 "Mighty Mouse" harsh environment connectors for maximum performance and minimum size.

FEP jackets meet FAA flammability requirements. Or, choose low smoke/ zero halogen polyurethane jackets for mass transit or shipboard applications.

Three Strain Relief Options – Overmolded, threaded backshell or heatshrink boots.

Three reasons to specify Glenair Series 80 cordsets

1 Simplified Ordering: No need to buy cable, connectors, termination tools and strain reliefs.

2 Guaranteed Performance: All cordsets are 100% electrically tested.

3 Faster Delivery: Cable and connector components are in stock.

HOW TO ORDER CORDSETS

Step 1: Select the Connector Series

Table 1 lists the six types of Series 80 connectors. For more information on selecting a connector, please refer to the connector selection chart in the Introduction.

Step 2: Select the Cable

Table 2 contains specifications for standard data cables. The cable type also determines the connector layout. **4 pin connectors are used for 4 wire cables, and tem pin connectors are used for 8 wire cocables.**

Step 3: Select a Cable Jacket

Table 3 shows available jacket options. Choose FEP flourocarbon jackets for airframe and avionics applications, or choose low smoke/zero halogen polyurethane jackets for soldier systems, vehicles, and transit systems.

Step 4: Select a Cable-To-Connector Interface

Table 3 provides three ways to attach the cable to the connector:

1. Polyamide boot, overmolded with flexible strain relief
2. Aluminum backshell, shielded, watertight and removable
3. Heat-shrink boot, low smoke/ zero halogen

Step 5: Select a Connector Configuration

Table 1 shows connector codes for specifying plug versus receptacle and pin versus socket contacts. Add a plating code, keying option and length.



Series 80 "Mighty Mouse" ASAP Cordsets For Ethernet, IEEE 1394 and USB 2.0

TABLE 1: HOW TO ORDER SERIES 80 CORDSETS FOR HIGH SPEED DATA

Sample Part Number									
801-021	B	R	P	A	C	M	P	Z	- 72
Connector Series	Cable	Cable Jacket	Strain Relief	Connector End A P1	Connector End B P2	Shell Material / Finish	Protective Cover	Shell Pol. Pos.	OAL Length
800-035 Series 800 Cordset, UNF Threaded Coupling, Hex Nut	A 100BASE-T Ethernet 4 Cond. UTP, OAL Shield 4 Pin Connector	F FEP Fluorocarbon Jacket, Translucent Blue	P Polyamide Overmold	A Plug, with Male Pin Contacts	A Plug, with Male Pin Contacts	M Aluminum / Electroless Nickel	P Metal Protective Covers Included	N Normal	Overall Length In Inches
801-021 Series 801 Cordset, Double-Start Threaded Coupling	B 100BASE-T Ethernet Quad, OAL Shield, 4 Pin Connector	P Low Smoke/Zero Halogen Polyurethane Jacket, Black	B Aluminum Backshell	B Plug, with Female Socket Contacts	B Plug, with Female Socket Contacts	NF Aluminum / Cadmium with Olive Drab Chromate	N No Covers Supplied	X Pos. X	12 Inch Min.
803-007 Series 803 Cordset, Push-Pull With Bayonet Lock Coupling	C 1000BASE-T Gigabit Ethernet 8 Cond. UTP, OAL Shield, 10 Pin Connector		H Heat-Shrink Boot, Low Smoke/Zero Halogen	C Receptacle, with Male Pin Contacts	C Receptacle, with Male Pin Contacts	ZN Aluminum / Zinc-Nickel with Olive Drab Chromate		Y Pos. Y	
804-013 Series 804 Cordset, Quick-Disconnect Push-Pull	D IEEE 1394 Hi-Speed Quad 110 Ohm, 4 Pin Connector			D Receptacle, with Female Socket Contacts	D Receptacle, with Female Socket Contacts	ZNU Aluminum / Zinc-Nickel with Black Chromate		Z Pos. Z	
805-007 Series 805 Cordset, Tri-Start Threaded Coupling with Ratchet and Ground Spring	E USB 2.0, Two #22 Power, One STP #26				N No Connector (Single-Ended)	Z1 Stainless Steel / Passivated			
	F Two STP, 100 Ohm, OAL Shield, 4 Pin Connector					TBD			
	G Four STP, 100 Ohm, OAL Shield, 10 Pin Connector								

**Series 80 "Mighty Mouse"
ASAP Cordsets For Ethernet, IEEE 1394 and USB 2.0**



TABLE 2: CABLE SPECIFICATIONS



	Cable Code						
	A	B	C	D	E	F	G
Cable Type	100BASE-T	100BASE-T	1000BASE-T	IEEE 1394	USB 2.0	100 Ω STP	100 Ω STP
Construction	UTP	Quad	UTP	Quad	STP	STP	STP
Number of Pairs	2		4	-	1	2	4
Number of Conductors	4	4	8	4	4	4	8
Conductor AWG	24	24	24	24	26 & 22	26	26
Conductor Material	SCCA	SCCA	SCCA	SCCA	SCCA	SCCA	SCCA
Conductor Insulation	FEP	FEP	FEP	PTFE	FEP	FEP	FEP
Inner Shield	AM	AM	AM	SCCB	AM	AM	AM
Outer Shield	SCCB	SCCB	SCCB	SCCB	SCCB	SCCB	SCCB
Shield Coverage	95% Min.	95% Min.	92%	95%	95%	95%	95%
Impedance	100 ± 10 Ω	100 ± 10 Ω	100 ± 10 Ω	110 ± 6 Ω	90 ± 13 Ω		
Capacitance (pF/ft.)	13.0	15.6	14.5	12.0	13.0		
Propagation Velocity	80%	69.5%	70%				
Skew (ps/ft.)				3.5			
Attenuation (dB/100 ft.) 10MHz	1.9	1.9	2.4	6.8			
Attenuation (dB/100 ft.) 100 MHz	6.7	6.7	8.0				
Attenuation (dB/100 ft.) 500 MHz				15.5			
Attenuation (dB/100 ft.) 1GHz				22.5			
Near-End Crosstalk dB @10MHz	47	53	50.3				
Near-End Crosstalk dB @100MHz	32	38	35.3				
Dielectric Withstanding Voltage	1500 VAC	1500 VAC	1500 VAC	1000 VAC			

TABLE 3: CABLE JACKET OPTIONS

	Jacket Code			
	F		R	
Jacket Material	Extruded FEP		Low Smoke/ Zero Halogen Polyurethane	
Typical Use	Airframe, Avionics, Missile		Dismounted Soldier, Shipboard, Armored Vehicle, Railcar	
UL Rating	94 V-0		94 V-0	
FAA Flammability	FAR 23.1359 FAR 25.853(a) FAR 25.869(a)(4)		FAR 25.853(a)	
Temperature Range			-30 to +105° C.	
Resistance to Solvents	Excellent		Excellent	
Flexibility	Good		Excellent	
Abrasion Resistance	Excellent		Excellent	
Color	Translucent Blue		Black	
Smoke Index NES 711			24	
Toxicity Index NES 713			3.9	
Oxygen Index ASTM D-2863	95%		28%	
Overall Cable Diameter	Cable Code	Diameter	Cable Code	Diameter
	A	.210 (5.33)	A	
	B	.175 (4.45)	B	
	C	.265 (6.73)	C	
	D	.190 (4.83)	D	
	E		E	
	F		F	
G		G		

TABLE 4: CABLE-TO-CONNECTOR INTERFACE (STRAIN RELIEF)

Strain Relief Code

	P	B	H
			
	Polyamide Overmold	Aluminum Backshell	Heat-Shrink Boot
Material	Polyamide	6061-T6 Aluminum	Polyolefin
Max. Operating Temperature	105° C.	150° C.	105° C.
Hardness	75 Shore A	N/A	
Low temperature Brittle Point	< -45° C.	N/A	< -55° C.
Volume Resistivity	>10 ¹² Ohms cm	N/A	
Dielectric Strength	>12 kV/mm	N/A	>12 kV/mm
Flammability (UL 94)	V0 Vertical Burn	N/A	V0 Vertical Burn
Smoke Index (NES 711)	<10	N/A	9.0
Toxicity Index (NES 713)	<7	N/A	1.9
Resistance to Ozone	Excellent	N/A	Excellent
Oil Resistance	Good	N/A	Good
Polar Solvents (alcohol)	Poor	N/A	Good
Non-polar Solvents	Good	N/A	Good
Fuel Resistance	Good	N/A	Fair
Immersion	1 meter MIL-STD-810 Method 512	IP67	1 meter MIL-STD-810 Method 512
Part Number	(Not Sold Separately)	390MS076	809S060

J

Series 80 "Mighty Mouse" ASAP Cordsets For Ethernet, IEEE 1394 and USB 2.0



ASAP CORDSET DIMENSIONS

**Strain relief
Code P**

**Polyamide
Overmold**

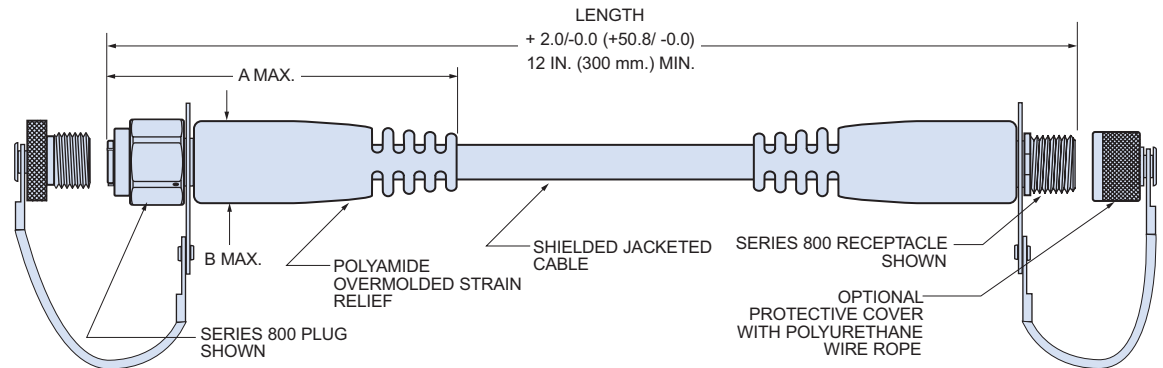

**Strain relief
Code B**

Metal Backshell

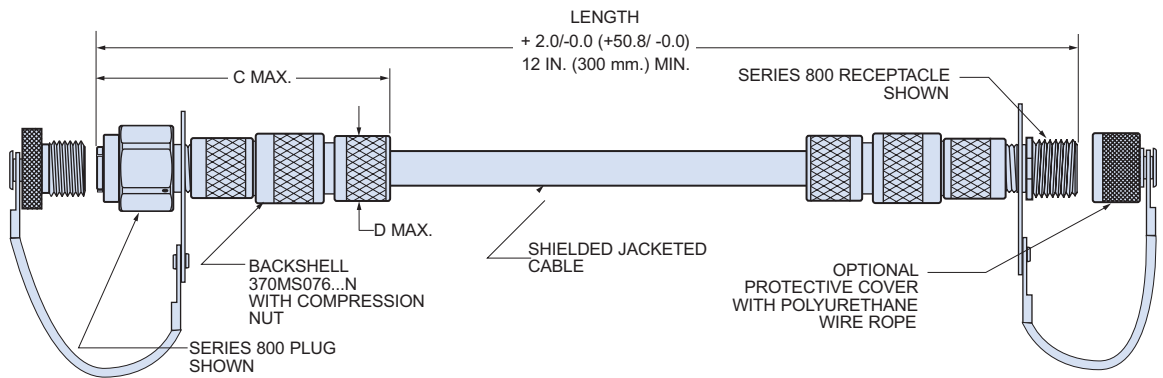

**Strain relief
Code H**

Heatshrink Boot

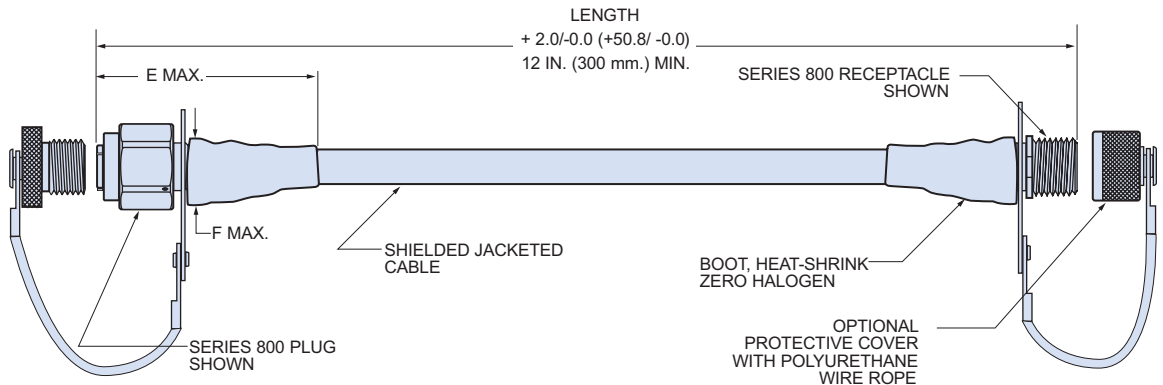

DIMENSIONS

Cable Code	Type	Number of Connector Pins	Nom. Cable Dia.		A Max.		B Max.		C Max.		D Max.		E Max.		F Max.	
			In.	mm.	In.	mm.	In.	mm.	In.	mm.	In.	mm.	In.	mm.	In.	mm.
A	2 Pair UTP 100 Ω	4	.210	5.33	2.50	63.5	.56	14.2	2.10	53.3	.53	13.5	1.60	40.6	.47	11.9
B	Quad 100 Ω	4	.175	4.45	2.50	63.5	.56	14.2	2.10	53.3	.53	13.5	1.60	40.6	.47	11.9
C	4 Pair UTP 100 Ω	10	.265	6.75	2.50	63.5	.68	17.3	2.10	53.3	.60	15.2	1.60	40.6	.58	14.7
D	Quad 110 Ω	4	.190	4.83	2.50	63.5	.56	14.2	2.10	53.3	.53	13.5	1.60	40.6	.47	11.9
E	USB 90 Ω	4			2.50	63.5	.56	14.2	2.10	53.3	.60	15.2	1.60	40.6	.47	11.9
F	2 Pair STP 100 Ω	4			2.50	63.5	.56	14.2	2.10	53.3	.60	15.2	1.60	40.6	.47	11.9
G	4 Pair STP 100 Ω	10			2.50	63.5	.68	17.3	2.10	53.3	.60	15.2	1.60	40.6	.58	14.7

WIRING SCHEMATICS FOR TYPE A AND TYPE B CABLE



**WIRING DIAGRAM
CABLE TYPE A
100BASE-T UTP**

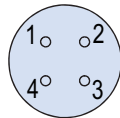
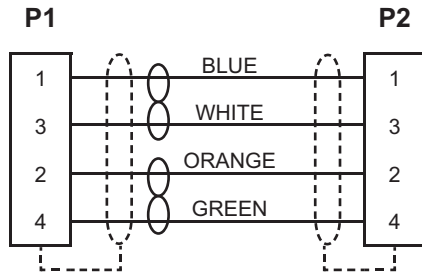

Pin Connector
Mating Face

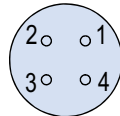

Socket Connector
Mating Face

**WIRING DIAGRAM
CABLE TYPE B
100BASE-T QUAD**

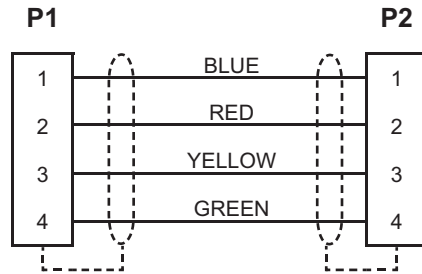

WIRING SCHEMATIC FOR TYPE C CABLE FOR GIGABIT ETHERNET APPLICATIONS

J



**10 Pin Connector
for Gigabit
Ethernet**

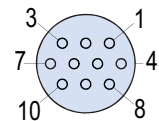

Pin Connector
Mating Face

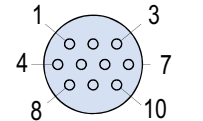

Socket Connector
Mating Face

**WIRING DIAGRAM
CABLE TYPE C
1000BASE-T UTP**

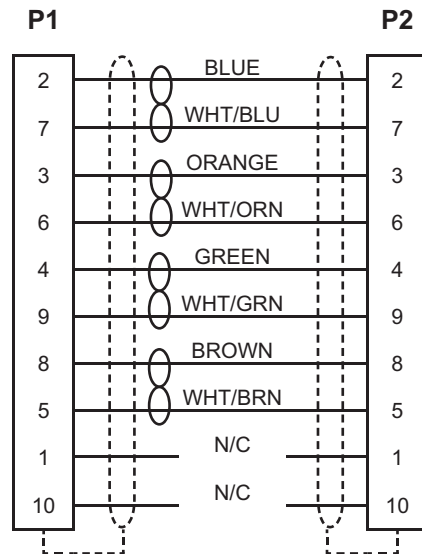

WIRING SCHEMATIC FOR TYPE D QUAD CABLE FOR IEEE 1394 APPLICATIONS



4 Pin Connector for
IEEE 1394

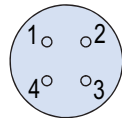

Pin Connector
Mating Face

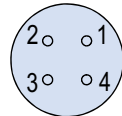

Socket Connector
Mating Face

WIRING DIAGRAM
CABLE TYPE D
1394 QUAD

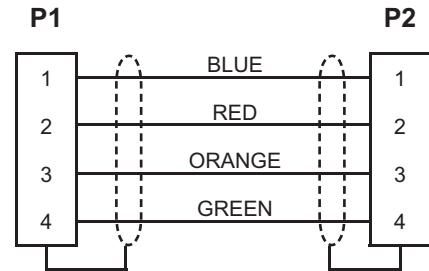

WIRING SCHEMATIC FOR TYPE E CABLE FOR USB 2.0 APPLICATIONS

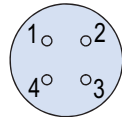
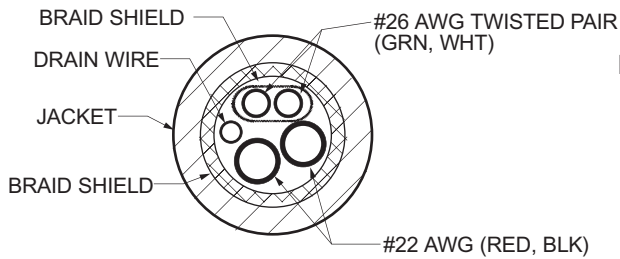

Pin Connector
Mating Face

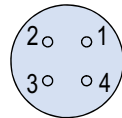

Socket Connector
Mating Face

WIRING DIAGRAM
CABLE TYPE E
USB 2.0

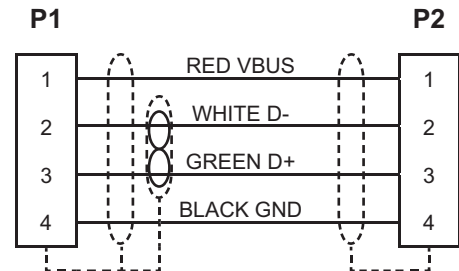

J

WIRING SCHEMATIC FOR TYPE F CABLE FOR 100 OHM STP APPLICATIONS

**WIRING DIAGRAM
 CABLE TYPE F
 TWO 100 OHM SHIELDED TWISTED
 PAIRS WITH OVERALL SHIELD**

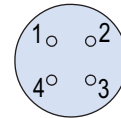
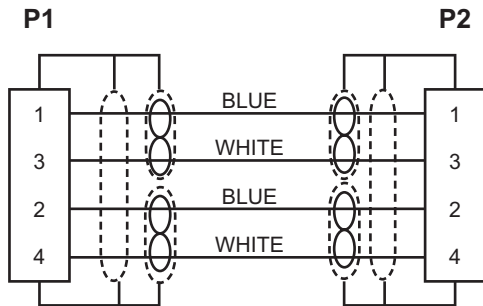

Pin Connector
 Mating Face

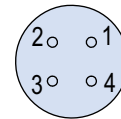

Socket Connector
 Mating Face

WIRING SCHEMATIC FOR TYPE G CABLE FOR 100 OHM STP APPLICATIONS

**WIRING DIAGRAM
 CABLE TYPE G
 FOUR STP**

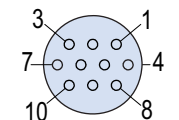
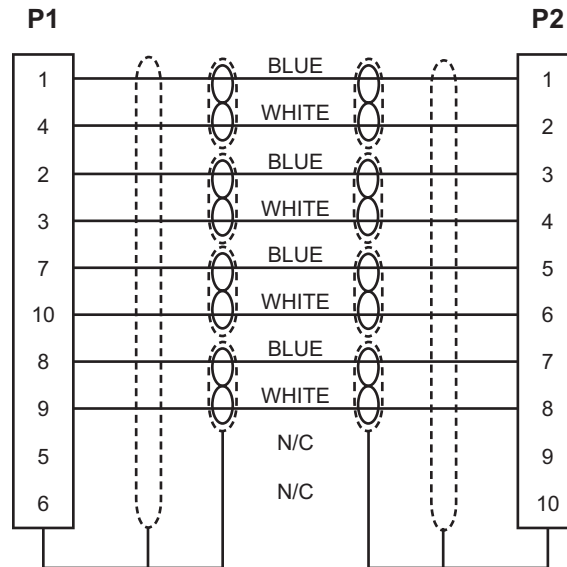

Pin Connector
 Mating Face

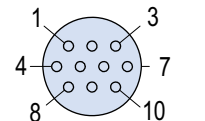

Socket Connector
 Mating Face