

DATA SHEET

SAA4961

Integrated multistandard comb filter

Preliminary specification
File under Integrated Circuits, IC02

1997 Feb 03

PHILIPS 85



Integrated multistandard comb filter

SAA4961

FEATURES

- One chip adaptive multistandard comb filter
- Time discrete but continuous amplitude signal processing with analog interfaces
- Internal delay lines, filters, clock processing and signal switches
- Alignment-free
- No hanging dots or residual cross colour on vertical transients
- Few external components.

GENERAL DESCRIPTION

The SAA4961 is an adaptive alignment-free one chip comb filter compatible with both PAL and NTSC systems and provides high performance in Y/C separation.

QUICK REFERENCE DATA

SYMBOL	PARAMETER	MIN.	TYP.	MAX.	UNIT
V _{CCA}	analog supply voltage	4.75	5	5.5	V
V _{DDD}	digital supply voltage	4.75	5	5.5	V
V _{CCO}	analog supply voltage output buffer	4.75	5	5.5	V
V _{CCPLL}	analog supply voltage PLL	4.75	5	5.5	V
I _{CCO}	analog supply current output buffer	–	70	90	mA
I _{DDD}	digital supply current	–	10	20	mA
I _{CCA}	analog supply current	–	35	40	mA
I _{CCPLL}	analog supply current PLL	–	1.5	3.0	mA
V _{17(p-p)}	CVBS and Y input signal (peak-to-peak value)	0.7	1	1.4	V
V _{10(p-p)}	chrominance input signal (peak-to-peak value)	–	0.7	1	V
V _{1(p-p)}	subcarrier input signal (peak-to-peak value)	100	200	400	mV
V _{14(p-p)}	luminance output signal (peak-to-peak value)	0.6	1	1.54	V
V _{12(p-p)}	chrominance output signal (peak-to-peak value)	–	0.7	1.1	V
V _{15(p-p)}	CVBS and Y output signal (peak-to-peak value)	0.6	1	1.54	V

ORDERING INFORMATION

TYPE NUMBER	PACKAGE		
	NAME	DESCRIPTION	VERSION
SAA4961	DIP28	plastic dual in-line package; 28 leads (600 mil)	SOT117-1

Integrated multistandard comb filter

SAA4961

BLOCK DIAGRAM

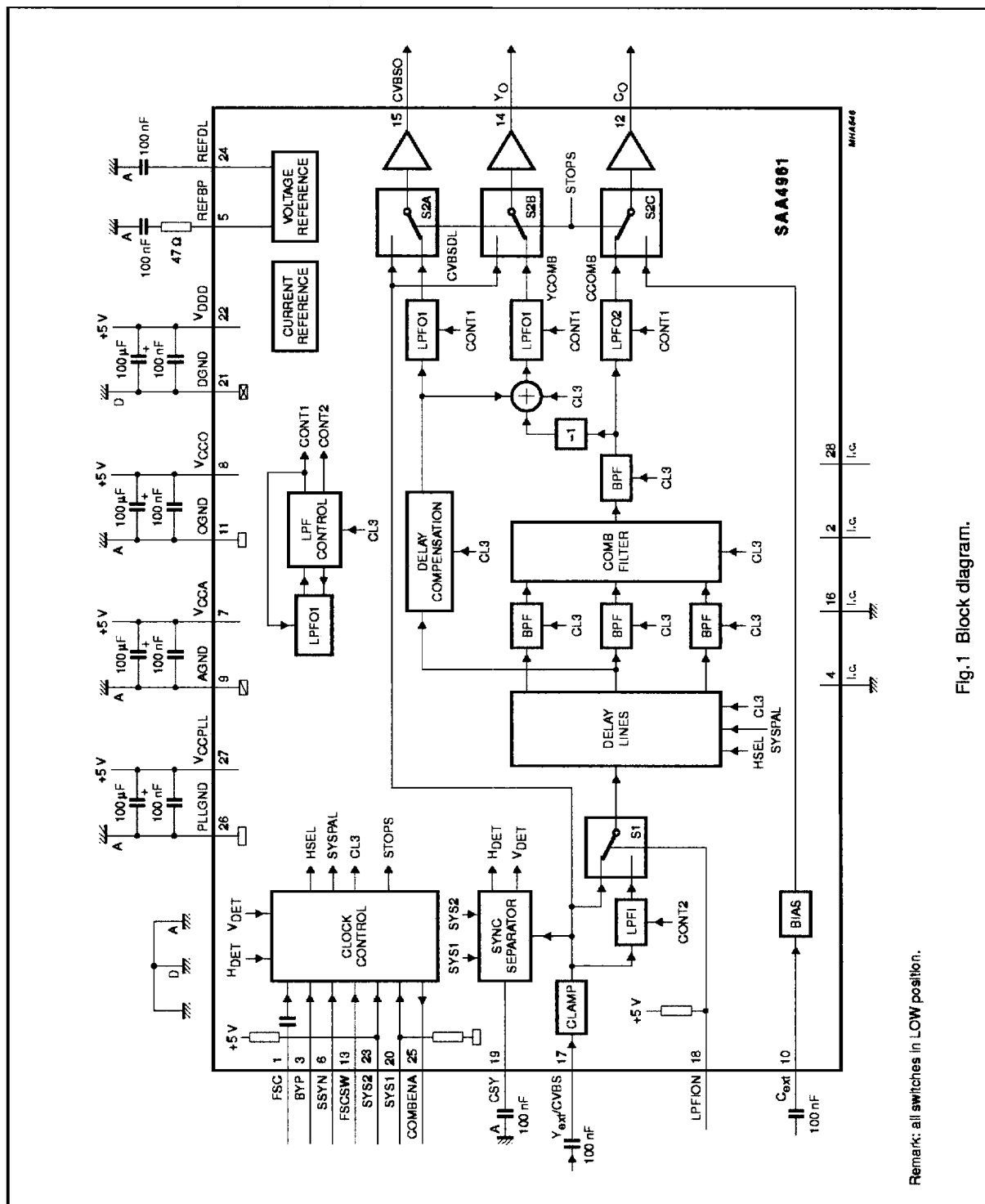

Fig.1 Block diagram.

Integrated multistandard comb filter

SAA4961

PINNING

SYMBOL	PIN	DESCRIPTION
FSC	1	subcarrier frequency input
i.c.	2	internally connected
BYP	3	bypass mode forcing input
i.c.	4	internally connected
REFBP	5	decoupling capacitor for band-pass filter reference
SSYN	6	bypass definition input
V _{CCA}	7	analog supply voltage
V _{CCO}	8	analog supply voltage output buffer
AGND	9	analog ground (signal reference)
C _{ext}	10	external chrominance input signal
OGND	11	analog ground output buffer
C _O	12	chrominance output signal
FSCSW	13	f _{sc} reference selection input
Y _O	14	luminance output signal
CVBSO	15	uncombed CVBS output signal
i.c.	16	internally connected
Y _{ext} /CVBS	17	CVBS (VBS) input signal
LPFION	18	disable alias-filter
CSY	19	storage capacitor
SYS1	20	standard select 1 input
DGND	21	digital ground
V _{DDD}	22	digital supply voltage
SYS2	23	standard select 2 input
REFDL	24	decoupling capacitor for delay lines
COMBENA	25	COMB-mode output signal
PLLGND	26	analog ground PLL
V _{CCPLL}	27	analog supply voltage PLL
i.c.	28	internally connected

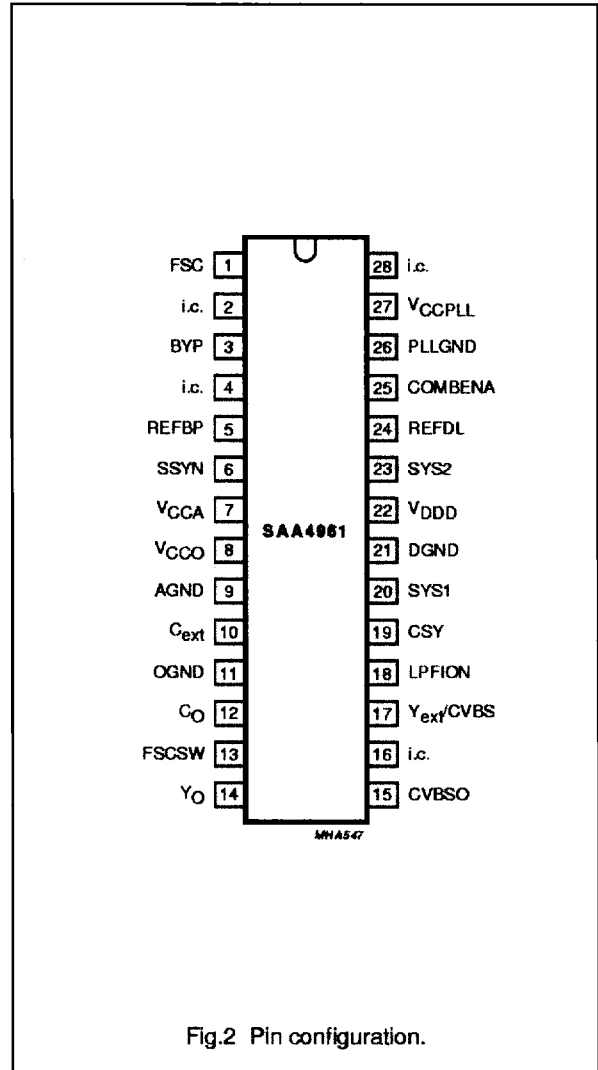

Fig.2 Pin configuration.

Integrated multistandard comb filter

SAA4961

FUNCTIONAL DESCRIPTION**Functional requirements**

The multistandard comb filter processes the video standards PAL B, G, H, M, N and NTSC M. PAL D and I signals can also be processed but with the drawback of a slightly reduced bandwidth.

For SECAM and SVHS signals the input signals can be bypassed to the output without processing by selecting the BYPASS-mode.

A sync separation circuit is incorporated to generate control signals for the internal clock processing. With a sync compression of up to 12 dB the sync separator works properly (see Fig.4).

The IC is controlled via six pins:

1. BYP forces the IC into the BYPASS-mode (comb filter function off)
2. SSYN defines whether the COMB-mode is entered synchronously or not and defines the polarity of the BYP pin
3. SYS1 selects the video standard
4. SYS2 selects the video standard
5. FSCSW selects the reference frequency f_{sc} or $2 \times f_{sc}$
6. LPFION enables the internal pre-filter.

It is possible to select the following modes of operation:

COMB-mode: luminance and chrominance comb filter function active if BYPASS-mode not active.

BYPASS-mode: signal processing not active, all clocks inactive, C_{ext} (pin 10) is bypassed to C_O (pin 12) and $Y_{ext}/CVBS$ (pin 17) is bypassed to Y_O (pin 14) and CVBSO (pin 15). This mode is forced via BYP (pin 3).

If the stimulus of the mode is changed, the IC is following the new mode after the stabilization time given in Table 1.

Table 1 Stabilization time after mode change

MODE CHANGE	MAXIMUM STABILIZATION TIME
COMB-mode to BYPASS-mode	1 line
BYPASS-mode to COMB-mode	1 field

The mode change from BYPASS to COMB depends on SSYN (pin 6) and can be asynchronous or synchronous related to the vertical pulse. The mode change from COMB to BYPASS is always performed asynchronously.

Pin description**FSC (PIN 1)**

Input for the reference frequency f_{sc} (see note 2 of Chapter "Characteristics") or $2 \times f_{sc}$. For SECAM standard signals the best signal performance in BYPASS-mode is achieved by switching the FSC input signal off externally.

BYP (PIN 3)

Input signal that controls the operation mode. A low-pass filter is added to the input for suppression of subcarrier frequencies. Thus applications are supported where the operation mode (COMB or BYPASS) is controlled by the DC-level of the FSC input signal at pin 1. For those applications the BYP input can be externally connected to FSC (pin 1).

Depending on SSYN (pin 6) the function of BYP can be adapted to a certain application with respect to the polarity of the logic level and with respect to the behaviour when entering the COMB-mode.

Depending on SSYN the BYP input can be either inverted or non-inverted with the function as shown in Table 2.

Table 2 Bypass function

SSYN	BYP	SELECTED MODE
LOW	LOW	COMB-mode
LOW	HIGH	BYPASS-mode
HIGH	LOW	BYPASS-mode
HIGH	HIGH	COMB-mode

Depending on SSYN the behaviour when entering the COMB-mode is different for the both selectable logic polarities while the BYPASS-mode is always entered asynchronously (immediately).

Table 3 Behaviour when entering the COMB-mode

SSYN	ENTERING COMB-MODE
LOW	immediately if BYP = LOW
HIGH	synchronized by vertical pulse if BYP = HIGH

The PLL and the clock processing are always stopped if the selected level for BYPASS is applied to BYP (independent of the vertical pulse).

Integrated multistandard comb filter

SAA4961

REFBP (PIN 5)

Decoupling capacitor for the band-pass filter reference voltage.

SSYN (PIN 6)

Input signal that controls the function of BYP (pin 3).

V_{CCA}, V_{CCO}, V_{DDD} AND V_{CCPLL} (PINS 7, 8, 22 AND 27)

Supply voltages.

AGND, OGND, DGND AND PLLGND (PINS 9, 11, 21 AND 26)

Ground connection. AGND is used as signal reference for all analog input and output signals.

C_{ext} (PIN 10)

Input for an external chrominance signal which is correlated to the external VBS signal.

C_O (PIN 12)

Chrominance output signal. This output can be switched between the comb filtered chrominance from the CVBS signal and the external chrominance signal from the input C_{ext} if the IC is forced into BYPASS-mode.

Table 4 C_O output signal

MODE	C _O OUTPUT SIGNAL
COMB	comb filtered chrominance signal
BYPASS	external chrominance signal of C _{ext} input

FSCSW (PIN 13)

Input signal to select between f_{sc} or 2 × f_{sc} as reference at the FSC input pin.

Table 5 Reference frequency selection

FSCSW	SELECTED REFERENCE
HIGH	2 × f _{sc}
LOW	f _{sc}

Y_O (PIN 14)

VBS output signal. This output can be switched between the comb filtered luminance signal (including synchronization) and the external (C)VBS signal from the input Y_{ext}/CVBS. In COMB-mode the output signal is delayed by 2 lines (1 line at NTSC) and by an additional processing delay.

Table 6 Y_O output signal

MODE	Y _O OUTPUT SIGNAL
COMB	comb filtered luminance signal
BYPASS	external CVBS signal of Y _{ext} /CVBS input

CVBSO (PIN 15)

CVBS output signal directly from the input in BYPASS-mode or delayed by the signal processing time of 2 lines (1 line at NTSC) and an additional processing delay.

Table 7 CVBSO output signal

MODE	CVBSO OUTPUT SIGNAL
COMB	delay compensated CVBS signal
BYPASS	external CVBS signal of Y _{ext} /CVBS input

Y_{ext}/CVBS (PIN 17)

Input for the CVBS signal or for an external VBS signal.

LPFION (PIN 18)

Input signal to disable the internal pre-filter LPFI.

Table 8 Pre-filter mode

LPFION	SELECTED MODE
LOW	LPFI inactive
HIGH	LPFI active
Floating	LPFI active

CSY (PIN 19)

Sync top capacitor for the sync separator.

Integrated multistandard comb filter

SAA4961

SYS1 AND SYS2 (PINS 20 AND 23)

System switch input signals to adapt the signal processing to the different CVBS standards.

Table 9 System switch input signals

SYS1	SYS2	STANDARD
LOW	LOW	PAL M
LOW	HIGH	PAL B, G, H, D and I; note 1
HIGH	LOW	NTSC M
HIGH	HIGH	PAL N

Note

1. The standard PAL B, G, H, D and I is internally preset as default.

REFDL (PIN 24)

Decoupling capacitor for the delay line reference voltage.

COMBENA (PIN 25)

Output signal that indicates the current mode of operation. This output is forced to LOW if the comb filter is in BYPASS-mode.

Table 10 Mode of operation

COMBENA	SELECTED MODE
LOW	BYPASS-mode; PLL and clock processing stopped
HIGH	COMB-mode

Internal functional description**SWITCHED CAPACITOR DELAY LINE**

Delays the CVBS input signal by 2 lines and 4 lines (all PAL standards) or by 1 line and 2 lines (NTSC standard). Input signals for the delay lines are the CVBS signal, the clock CL3 ($3 \times f_{sc}$), the control signal HSEL and the standard selection signal SYSPAL.

Output signals are the non-delayed, the 2-line delayed and the 4-line delayed CVBS signal (PAL) or the 1-line delayed and the 2-line delayed CVBS signal (NTSC).

SWITCHED CAPACITOR BAND-PASS FILTERS (BPFs)

The comb filter input BPFs attenuate the low frequencies to guarantee a correct signal processing within the logical comb filter.

The comb filter output BPF reduces the alias components that are the result of the non-linear signal processing within the logical comb filter.

LOGICAL COMB FILTER

Separates the chrominance from the band-pass filtered CVBS signal.

COMPENSATION DELAY

Compensates the internal processing time of the band-pass filters and the logical comb filter section.

ADDER

The comb filtered luminance output signal is obtained by adding the delayed CVBS signal and the inverted comb filtered chrominance signal.

LOW-PASS FILTER INPUT (LPFI)

Analog input low-pass filter to reduce the outband frequencies of EMC. The input low-pass filter is included in the signal path but it can be switched off via the input signal LPFION.

LOW-PASS FILTER OUTPUTS (LPFO1 AND LPFO2)

Two different types of output low-pass filters (LPFO1 and LPFO2) are necessary to get equal signal delays within the luminance path and the chrominance path (important for good transient behaviour). The low-pass output filter type LPFO1 is used for the luminance output while LPFO2 is used for the chrominance output. The filters are analog 3rd order elliptic low-pass filters that convert the output signals from the time discrete to the time continuous domain (reconstruction filter).

LPF CONTROL

Automatic tuning of the low-pass filters is achieved by adjusting the filter delays. The control information for all filters (CONT1 and CONT2) is derived from a built-in reference filter (LPFO1-type) that is part of a control loop. The control loop tunes the reference filter delay and thus all other filter delays to a time constant derived from the system clock CL3.

CONTROL AND CLOCK PROCESSING (CLOCK CONTROL)

The control and clock processing block (see Fig.9) consists of the sub-blocks PLL, the clock processing and the mode control. The PLL and the clock processing are released for operation if the input level at BYP selects the COMB-mode.

Integrated multistandard comb filter

SAA4961

Main tasks of the control and clock processing are:

- Clock generation of system clock CL3
- Delay line start control
- Mode control.

The signal processing is based on a $3 \times f_{sc}$ system clock (CL3), that is generated by the clock processing from the f_{sc} signal at FSC (pin 1) via a PLL. Because the subcarrier frequency divided by the line frequency results not in an integer value a clock phase correction of 180° is necessary every second line for PAL standards or every line for NTSC standard. The clock phase correction is controlled by the input signals horizontal sync. Additionally the delay line start is synchronized once a field to the input signals horizontal sync. The 25 Hz PAL offset is corrected in this way.

The PLL provides a master clock MCK of $6 \times f_{sc}$, which is locked to the subcarrier frequency at FSC (pin 1).

The system clock CL3 ($3 \times f_{sc}$) is obtained from MCK by a divide-by-two circuit. The 180° phase shift is generated by stopping the divide-by-two circuit for one MCK clock cycle.

The generated clock is a pseudo-line-locked clock that is referenced to f_{sc} . The sync separator generates the necessary signals H_{DET} and V_{DET} indicating the line (H) and the field (V) sync periods.

The current mode of operation (BYPASS or COMB) is external readable via COMBENA (pin 25).

The input signals of the control and clock processing (CLOCK CONTROL) are:

- H_{DET} : analog horizontal pulse from sync separator
- V_{DET} : analog vertical pulse from sync separator
- FSC: subcarrier frequency (f_{sc} or $2 \times f_{sc}$)
- FSCSW: reference frequency selection
- BYP: BYPASS control signal
- SSYN: vertical synchronous mode selection for BYP and polarity selection of BYP.

The output signals are:

- CL3: system clock ($3 \times f_{sc}$)
- HSEL: line start signals for the delay lines
- STOPS: forces the comb filter via the switches S2A, S2B and S2C into the BYPASS-mode (always asynchronous) or COMB-mode (synchronous or asynchronous with V_{INT} ; depending on SSYN)
- COMBENA: HIGH during COMB-mode; otherwise LOW.

Table 11 Function of STOPS signal

STOPS-STATE	SELECTED MODE
LOW	COMB
HIGH	BYPASS

HORIZONTAL AND VERTICAL SYNC SEPARATOR

A built-in sync separator circuit generates the H_{DET} and V_{DET} signals from the $Y_{ext}/CVBS$ input signal. This circuit is still operating properly at input signals with a 12 dB attenuated sync in a normal 700 mV black-to-white video signal (see Fig.4).

CLAMP

The black level clamping of the video input signal is performed by the sync separator stage. The clamping level is nearly adequate to the voltage at REF DL (pin 24).

SIGNAL SWITCH S1

The switch is included to bypass the low-pass input filter. For the CVBS input of the delay line block two signals can be selected via the slow signal switch S1.

Table 12 Function of signal switch S1

LPFION-STATE	DELAY LINE INPUT
LOW	non-pre-filtered input signal $Y_{ext}/CVBS$
HIGH	pre-filtered input signal $Y_{ext}/CVBS$
Floating	pre-filtered input signal $Y_{ext}/CVBS$

SIGNAL SWITCH S2A

For the CVBSO output two signals can be selected via the signal switch S2A.

Table 13 CVBSO output signal

STOPS-STATE	CVBSO OUTPUT SIGNAL	MODE
LOW	delayed input CVBSDL	COMB
HIGH	non-delayed input $Y_{ext}/CVBS$	BYPASS

SIGNAL SWITCH S2B AND S2C

Two switches are included to bypass the comb filter signal processing. The input video signal C_{ext} for the switch S2C is internally biased.

Integrated multistandard comb filter

SAA4961

For the Y_O output two signals can be selected via S2B (see Table 14).

For the C_O output two signals can be selected via S2C (see Table 15).

Table 14 Y_O output signal

STOPS-STATE	Y_O OUTPUT SIGNAL	MODE
LOW	YCOMB (combed luminance)	COMB
HIGH	input Y_{ext} /CVBS	BYPASS

Table 15 C_O output signal

STOPS-STATE	C_O OUTPUT SIGNAL	MODE
LOW	CCOMB (combed chrominance)	COMB
HIGH	input C_{ext}	BYPASS

LIMITING VALUES

In accordance with the Absolute Maximum Rating System (IEC 134).

SYMBOL	PARAMETER	CONDITIONS	MIN.	MAX.	UNIT
V_{CC}	supply voltage		–	6.5	V
V	input voltage protection threshold	except pin 1	–0.3	$V_{CC} + 0.3$	V
I_{CC}	total supply current		–	155	mA
I_O	output current (C_O , Y_O and CVBSO)		–	± 15	mA
	output current (COMBENA)		–	10	mA
P_{tot}	total power dissipation		–	900	mW
T_{amb}	operating ambient temperature		0	70	$^{\circ}\text{C}$
T_{stg}	storage temperature		–25	+150	$^{\circ}\text{C}$
V_{es}	electrostatic handling	note 1			

Note

- Human Body Model: C = 100 pF; R = 1.5 k Ω ; V = 2 kV; machine model: C = 200 pF; R = 0 Ω ; V = 300 V.

THERMAL CHARACTERISTICS

SYMBOL	PARAMETER	VALUE	UNIT
$R_{th\ j-a}$	thermal resistance from junction to ambient in free air	31	K/W

Integrated multistandard comb filter

SAA4961

CHARACTERISTICS

$V_{DD} = V_{CCA} = V_{CCO} = V_{CCPLL} = 5\text{ V}$; $T_{amb} = 25\text{ }^{\circ}\text{C}$; input signal $Y_{ext}/CVBS = 1\text{ V}$ (p-p) (0 dB); input signal $C = 0.7\text{ V}$ (p-p) (0 dB); input signal $FSC = 200\text{ mV}$ (p-p), sine wave, DC level = 2 V; input signal $LPFION = 5\text{ V}$; test signal: EBU colour bar 100/0/75/0 "CCIR471-1"; source impedance for $Y_{ext}/CVBS$, $C_{ext} = 75\text{ }\Omega$ decoupled with 100 nF; source impedance for $FSC = 75\text{ }\Omega$; load impedance for $CVBSO$, Y_O , $C_O = 1\text{ k}\Omega$ and 20 pF in parallel; unless otherwise specified.

SYMBOL	PARAMETER	CONDITIONS	MIN.	TYP.	MAX.	UNIT
Supply voltage						
V_{CCA}	analog supply voltage (pin 7)	note 1	4.75	5	5.5	V
V_{CCO}	analog supply voltage output buffer (pin 8)	note 1	4.75	5	5.5	V
V_{DDD}	digital supply voltage (pin 22)	note 1	4.75	5	5.5	V
V_{CCPLL}	analog supply voltage PLL (pin 27)	note 1	4.75	5	5.5	V
FSC (pin 1)						
$V_{1(p-p)}$	input AC voltage (peak-to-peak value)		100	200	400	mV
	input AC voltage is valid for sine wave square wave		– 0.4	– 0.5	– 0.6	– duty cycle
V_1	input DC level		0	–	5.3	V
C_1	input capacitance		–	–	10	pF
I_{leak}	input leakage current		–	–	10	μA
Z_1	source impedance		–	–	800	Ω
BYP (pin 3)						
V_{IH}	HIGH level input voltage		2.4	–	V_{CC}	V
V_{IL}	LOW level input voltage		0	0.85	1.5	V
I_{leak}	input leakage current		–	–	10	μA
C_3	input capacitance		–	–	10	pF
REFBP (pin 5)						
V_5	DC voltage		1.1	1.25	1.4	V
SSYN (pin 6)						
V_{IH}	HIGH level input voltage		2.4	–	V_{CC}	V
V_{IL}	LOW level input voltage		0	0.85	1.5	V
I_{leak}	input leakage current		–	–	10	μA
C_6	input capacitance		–	–	10	pF
V_{CCA} (pin 7)						
I_{CCA}	analog supply current		–	35	40	mA
V_{CCO} (pin 8)						
I_{CCO}	supply current		–	70	90	mA

Integrated multistandard comb filter

SAA4961

SYMBOL	PARAMETER	CONDITIONS	MIN.	TYP.	MAX.	UNIT
C_{ext} (pin 10)						
V ₁₀	input voltage (AC coupled)		–	0	3	dB
R ₁₀	input resistance	1.25 V	500	700	1000	kΩ
C ₁₀	input capacitance		–	–	10	pF
Z ₁₀	source impedance		–	–	1	kΩ
C_o (pin 12)						
V ₁₀ /V ₁₂	BYPASS-mode: C _o /C _{ext}	f _{sc} ±0.3f _{sc} ; note 2	–1	0	+1	dB
COMB-mode: transfer function C-path see Fig.10						
V ₁₂	DC offset voltage related to input		–400	0	+400	mV
ΔV ₁₂	DC jump when forcing into BYPASS-mode		–	100	450	mV
R ₁₂	output resistance		–	10	100	Ω
R _L	load resistance (to ground)		0.3	–	–	kΩ
C _L	load capacitance (to ground)		–	–	25	pF
V ₁₇ /V ₁₂	suppression (comb depth)	see Figs 5 and 7; note 3				
	PAL B, G, H, D, I	283 × f _H	26	30	–	dB
		(283 – 43) × f _H	20	24	–	dB
		(283 + 35) × f _H	20	24	–	dB
	PAL M, NTSC M	227 × f _H	26	30	–	dB
		(227 – 35) × f _H	20	24	–	dB
		(227 + 28) × f _H	20	24	–	dB
	PAL N	229 × f _H	26	30	–	dB
		(229 – 35) × f _H	20	24	–	dB
		(229 + 28) × f _H	20	24	–	dB
FPN	fixed pattern noise for divided clock frequencies referenced to 0.7 V (p-p)	0.75f _{sc}	–	–	–30	dB
		f _{sc}	–	–	–50	dB
		1.5f _{sc}	–	–	–37	dB
		2f _{sc}	–	–	–30	dB
α _{cr}	crosstalk suppression at vertical transients no-colour ↔ colour (0.7 V/V _{eff})	see Fig.3	26	30	–	dB
S/N	signal-to-noise ratio (0.7 V/V _{eff} noise)	unweighted; f _{sc} ±0.3f _{sc} ; note 2	56	72	–	dB
α _{cr}	crosstalk between different inputs	0 to 5 MHz	–	–60	–40	dB
V _{12(p-p)}	FSC residue in BYPASS-mode related to 700 mV (p-p)		–	–	–60	dB
G _d	differential gain		0.95	–	–	

Integrated multistandard comb filter

SAA4961

SYMBOL	PARAMETER	CONDITIONS	MIN.	TYP.	MAX.	UNIT
FSCSW (pin 13)						
V_{IH}	HIGH level input voltage		2	–	V_{CC}	V
V_{IL}	LOW level input voltage		0	–	0.8	V
C_{13}	input capacitance		–	–	10	pF
I_{leak}	input leakage current		–	–	10	μ A
Y_o (pin 14)						
V_{14}/V_{17}	BYPASS-mode: C_O/C_{ext}	0 to 5 MHz	–1	0	+1	dB
COMB-mode: transfer function Y-path see Fig.11						
V_{14}	DC offset voltage related to input		–400	0	+400	mV
$ \Delta V_{14} $	DC jump when forcing into BYPASS-mode		–	200	450	mV
R_{14}	output resistance		–	10	100	Ω
R_L	load resistance (to ground)		0.3	–	–	k Ω
C_L	load capacitance (to ground)		–	–	25	pF
V_{17}/V_{14}	suppression (comb depth)	see Figs 6 and 8; note 3				
	PAL B, G, H, D, I	$283.75 \times f_H$	26	30	–	dB
		$(283.75 - 43) \times f_H$	10	12	–	dB
		$(283.75 + 35) \times f_H$	18	24	–	dB
	PAL M	$227.25 \times f_H$	26	30	–	dB
		$(227.25 - 35) \times f_H$	10	12	–	dB
		$(227.25 + 28) \times f_H$	18	24	–	dB
	PAL N	$229.25 \times f_H$	26	30	–	dB
		$(229.25 - 35) \times f_H$	10	12	–	dB
		$(229.25 + 28) \times f_H$	18	24	–	dB
	NTSC M	$227.5 \times f_H$	26	30	–	dB
		$(227.5 - 35) \times f_H$	10	12	–	dB
		$(227.5 + 28) \times f_H$	18	24	–	dB
FPN	fixed pattern noise for divided clock frequencies referenced to 0.7 V (p-p) black-to-white	$0.75f_{sc}$	–	–	–40	dB
		f_{sc}	–	–	–30	dB
		$1.5f_{sc}$	–	–	–30	dB
		$2f_{sc}$	–	–	–20	dB
α_{cr}	crosstalk suppression at vertical transients gray \leftrightarrow multi-burst (0.7 V/V _{eff})	see Fig.3	26	30	–	dB
S/N	signal-to-noise ratio (0.7 V/V _{eff} noise)	unweighted; 200 kHz to 5 MHz	56	72	–	dB
α_{cr}	crosstalk between different inputs	0 to 5 MHz	–	–60	–40	dB
$V_{14(p-p)}$	FSC residue in BYPASS-mode related to 700 mV (p-p)		–	–	–60	dB
G_d	differential gain		0.95	–	–	

Integrated multistandard comb filter

SAA4961

SYMBOL	PARAMETER	CONDITIONS	MIN.	TYP.	MAX.	UNIT
CVBSO (pin 15)						
V_{15}/V_{17}	BYPASS-mode: CVBSO/CVBS	0 to 5 MHz	-1	0	+1	dB
COMB-mode: transfer function CVBS-path see Fig.11						
V_{15}	DC offset voltage		-400	0	+400	mV
$ \Delta V_{15} $	DC jump when forcing into BYPASS-mode		-	200	450	mV
R_{15}	output resistance		-	10	100	Ω
R_L	load resistance (to ground)		0.3	-	-	k Ω
C_L	load capacitance (to ground)		-	-	25	pF
FPN	fixed pattern noise for divided clock frequencies referenced to 0.7 V (p-p) black-to-white	$0.75f_{sc}$	-	-	-40	dB
		f_{sc}	-	-	-30	dB
		$1.5f_{sc}$	-	-	-30	dB
		$2f_{sc}$	-	-	-20	dB
S/N	signal-to-noise ratio (0.7 V V_{eff} noise)	unweighted; 200 kHz to 5 MHz	56	72	-	dB
α_{cr}	crosstalk between different inputs	0 to 5 MHz	-	-60	-40	dB
$V_{15(p-p)}$	FSC residue in BYPASS-mode related to 700 mV (p-p)		-	-	-60	dB
G_d	differential gain		0.95	-	-	
P_d	differential phase		-	2	3	deg
$Y_{ext}/CVBS$ (pin 17)						
V_{17}	input voltage (AC coupled)	12 dB sync attenuation possible; see Fig.4	-3	0	+3	dB
I_{17}	input current	during sync pulse	-10	-8.0	-	μA
		during active video	-	0.84	1.5	μA
V_{17}	DC voltage during black level		1.1	1.25	1.4	V
Z_{17}	source impedance		-	-	1	k Ω
LPFION (pin 18)						
V_{IH}	HIGH level input voltage		2	-	V_{CC}	V
V_{IL}	LOW level input voltage		0	-	0.8	V
I_{18}	input current	0.8 V	-	8	20	μA
		2.0 V	-	8	20	μA
C_{18}	input capacitance		-	-	10	pF
CSY (pin 19)						
V_{19}	DC voltage		0	2	V_{CC}	V

Integrated multistandard comb filter

SAA4961

SYMBOL	PARAMETER	CONDITIONS	MIN.	TYP.	MAX.	UNIT
SYS1 (pin 20)						
V _{IH}	HIGH level input voltage		2	–	V _{CC}	V
V _{IL}	LOW level input voltage		0	–	0.8	V
I ₂₀	input current	0.8 V	–	7.5	20	μA
		2.0 V	–	7.5	20	μA
C ₂₀	input capacitance		–	–	10	pF
V_{DD} (pin 22)						
I _{DD}	supply current		–	10	20	mA
SYS2 (pin 23)						
V _{IH}	HIGH level input voltage		2	–	V _{CC}	V
V _{IL}	LOW level input voltage		0	–	0.8	V
I ₂₃	input current	0.8 V	–	8	20	μA
		2.0 V	–	8	20	μA
C ₂₃	input capacitance		–	–	10	pF
REFDL (pin 24)						
V ₂₄	DC voltage		1.1	1.25	1.4	V
COMBENA (pin 25)						
V _{OL}	LOW level output voltage	3 mA	0.26	0.4	0.55	V
V _{OH}	HIGH level output voltage		4	–	V _{CC}	V
I _{OH}	HIGH level output current	2.4 V	–55	–24	–	μA
V_{CCPLL} (pin 27)						
I ₂₇	supply current		–	1.5	3	mA

Notes

- $\Delta V = |V_{CCA} - V_{DD}| \leq 300 \text{ mV}$
 $\Delta V = |V_{CCA} - V_{CCO}| \leq 300 \text{ mV}$
 $\Delta V = |V_{CCO} - V_{DD}| \leq 300 \text{ mV}$
 All voltages are related to AGND.

$\Delta V = V_{CCA} - V_{CCPLL} \leq 300 \text{ mV}$
$\Delta V = V_{CCO} - V_{CCPLL} \leq 300 \text{ mV}$
$\Delta V = V_{DD} - V_{CCPLL} \leq 300 \text{ mV}$
- f_{sc} = subcarrier frequency
 $f_{sc} = 4.43361875 \text{ MHz}$ for PAL B, G, H, D, I
 $f_{sc} = 3.57561149 \text{ MHz}$ for PAL M
 $f_{sc} = 3.58205625 \text{ MHz}$ for PAL N
 $f_{sc} = 3.579545 \text{ MHz}$ for NTSC M.
- f_H = line frequency
 $f_H = 15.625 \text{ kHz}$ for PAL B, G, H, N, D, I
 $f_H = 15.734264 \text{ kHz}$ for PAL M, NTSC M.

Integrated multistandard comb filter

SAA4961

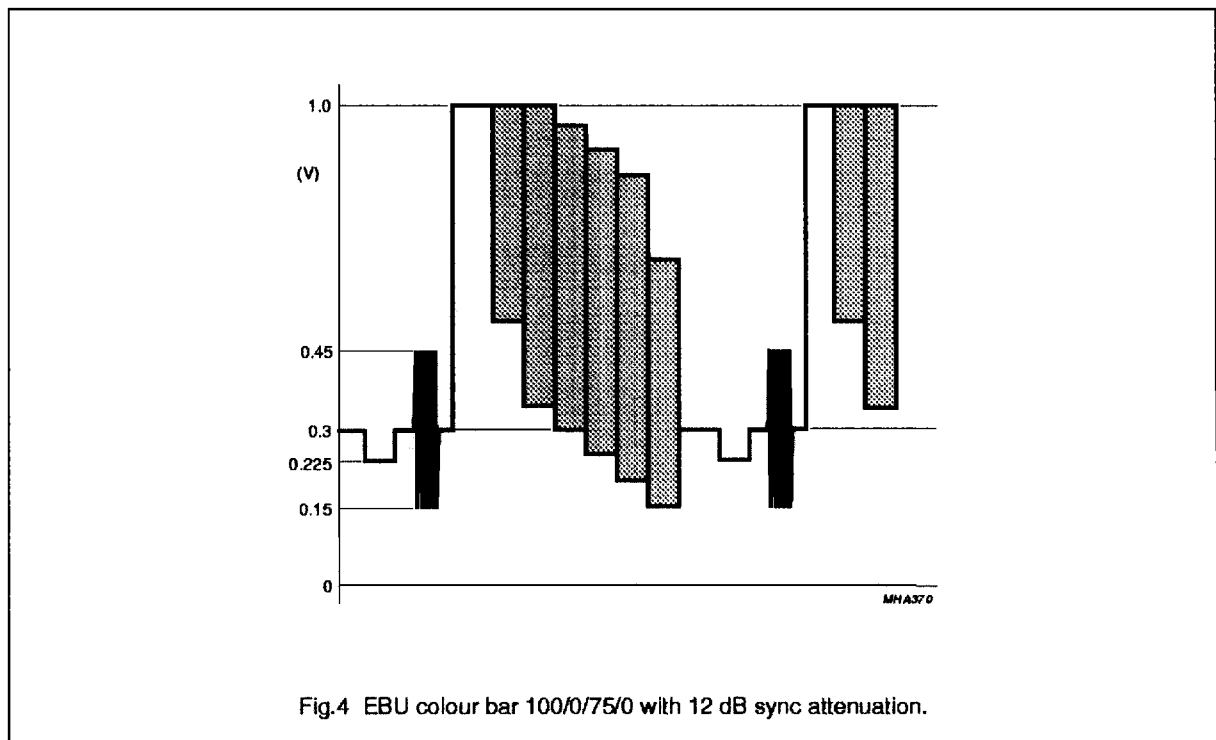
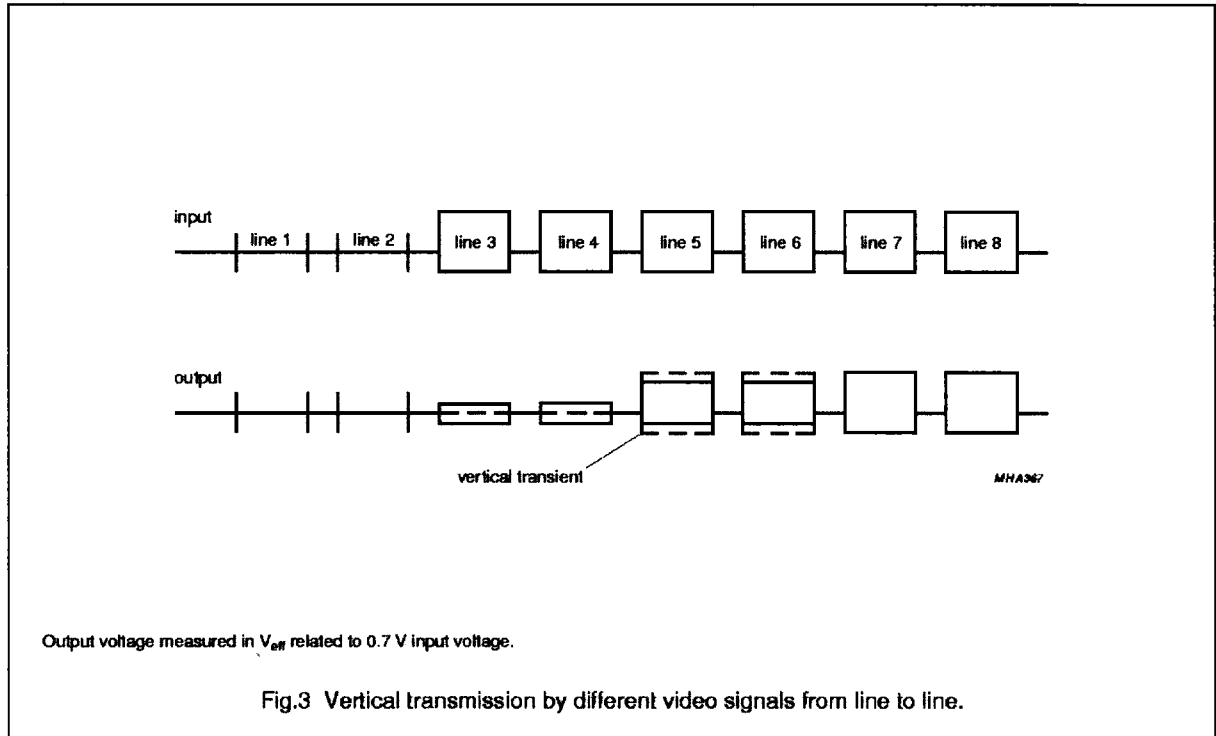

Integrated multistandard comb filter

SAA4961

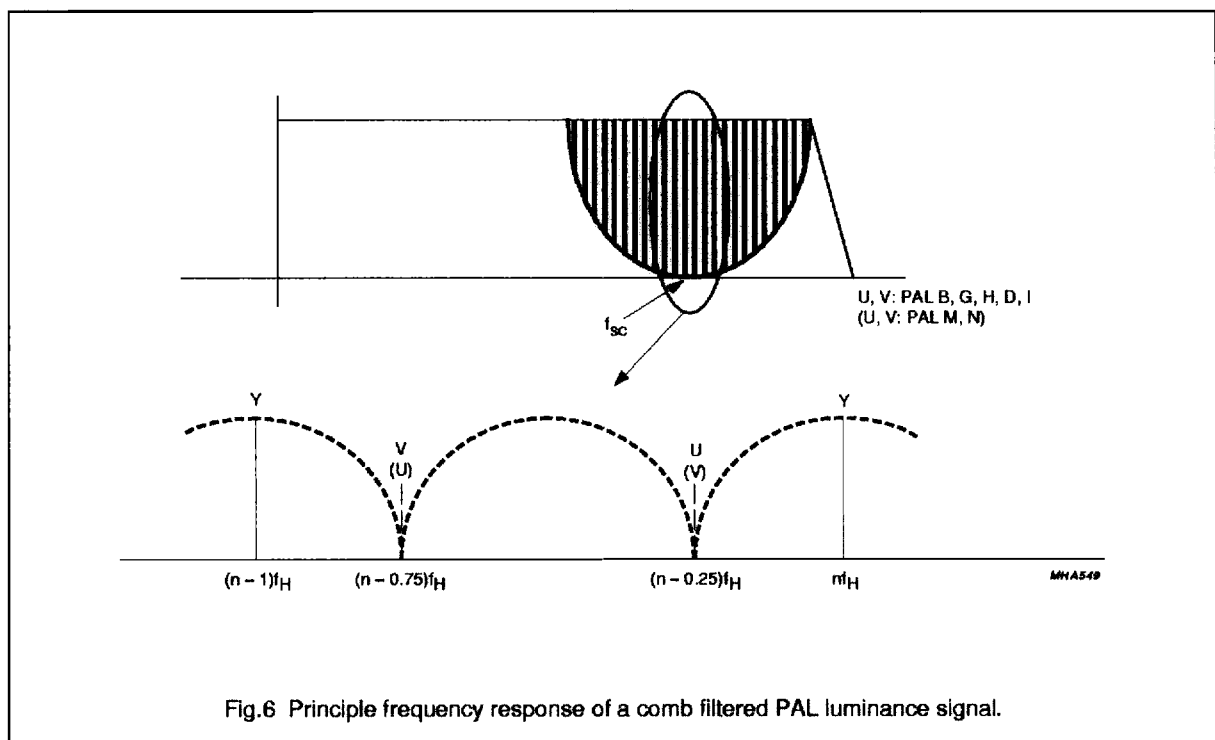
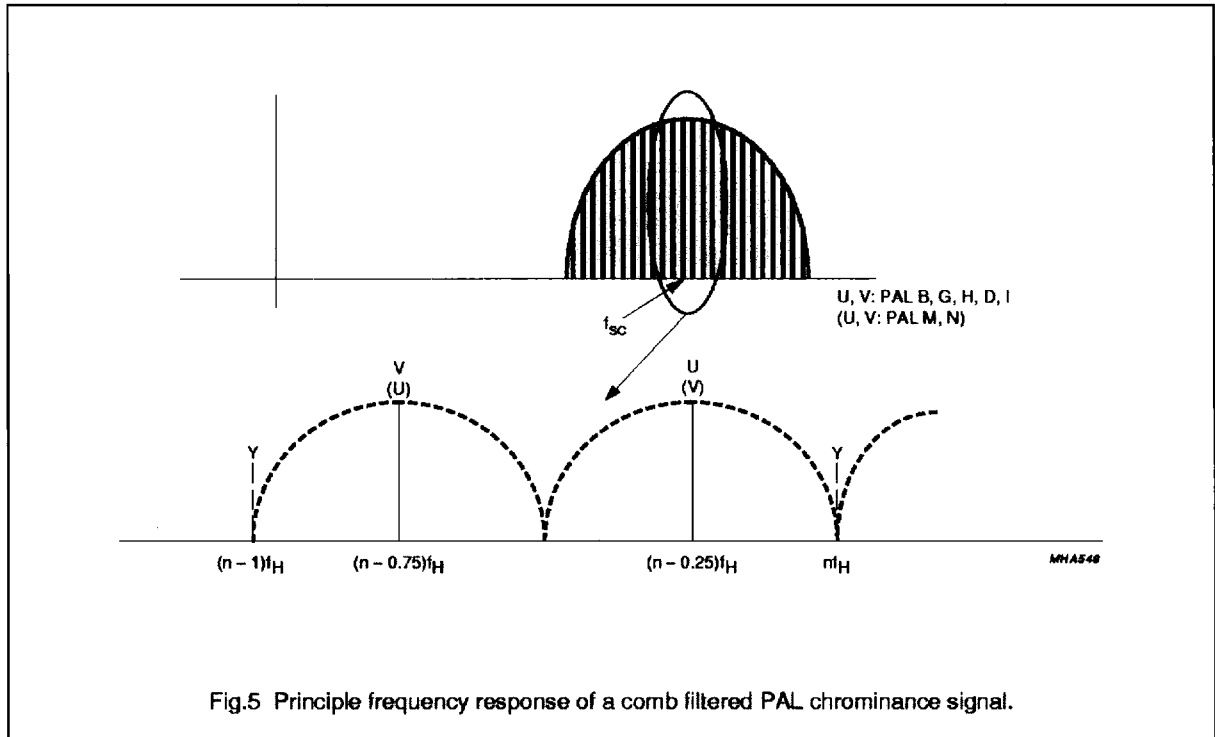

Integrated multistandard comb filter

SAA4961

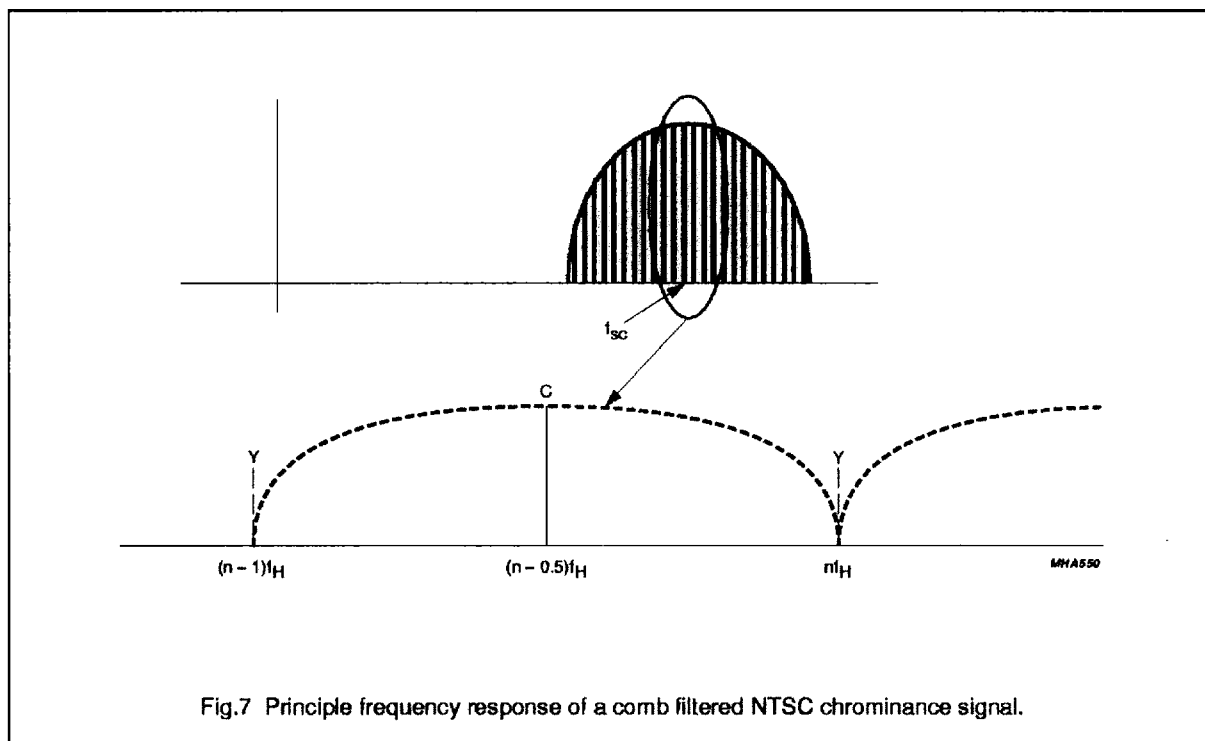

Fig.7 Principle frequency response of a comb filtered NTSC chrominance signal.

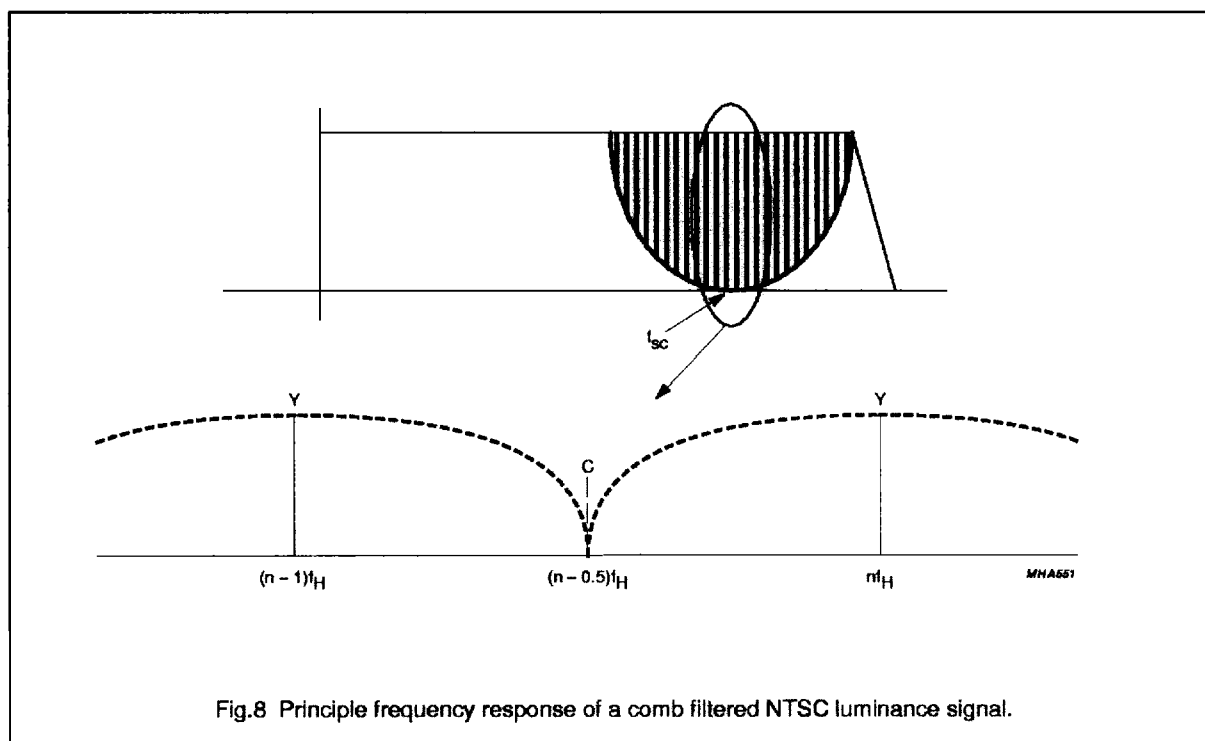

Fig.8 Principle frequency response of a comb filtered NTSC luminance signal.

Integrated multistandard comb filter

SAA4961

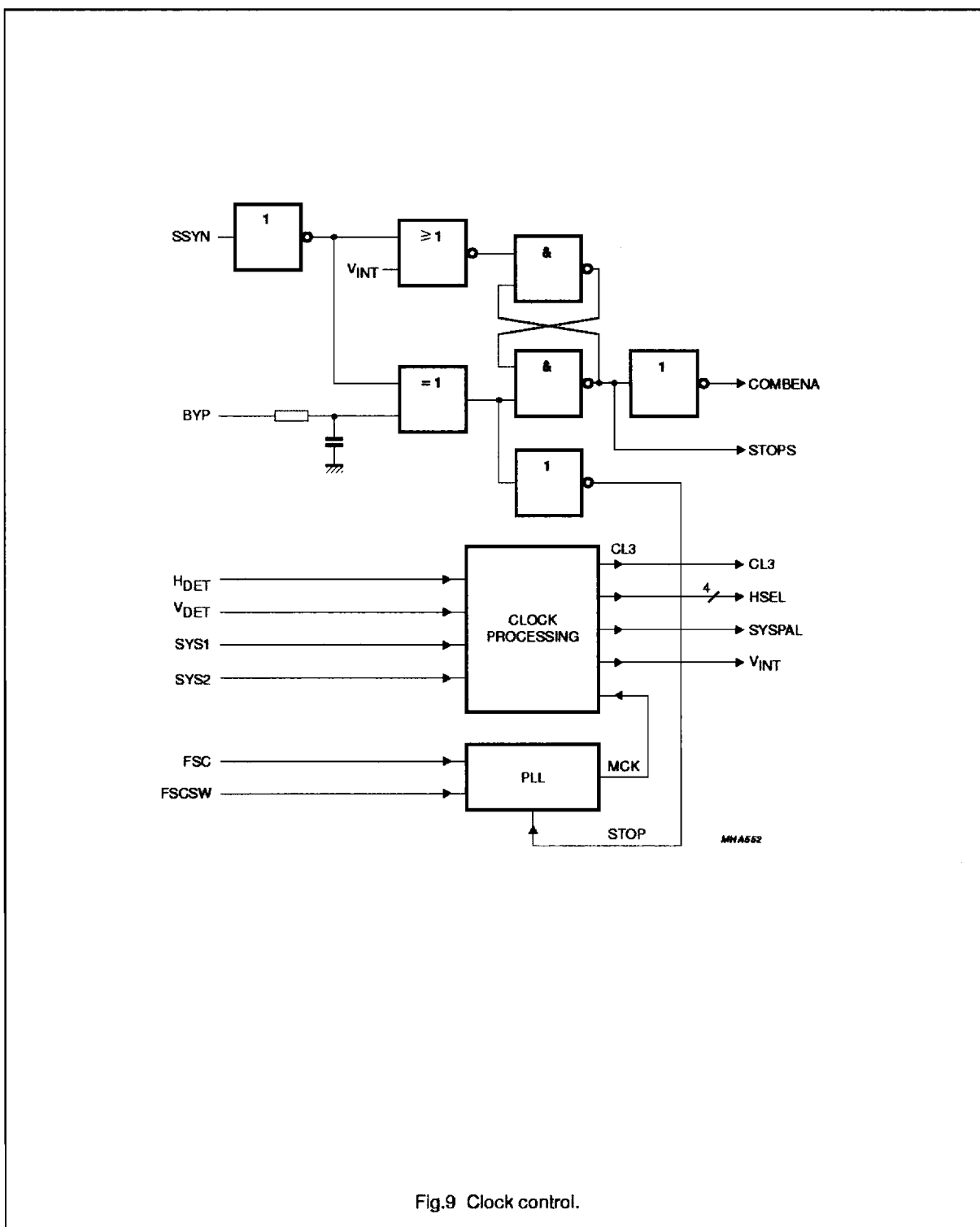
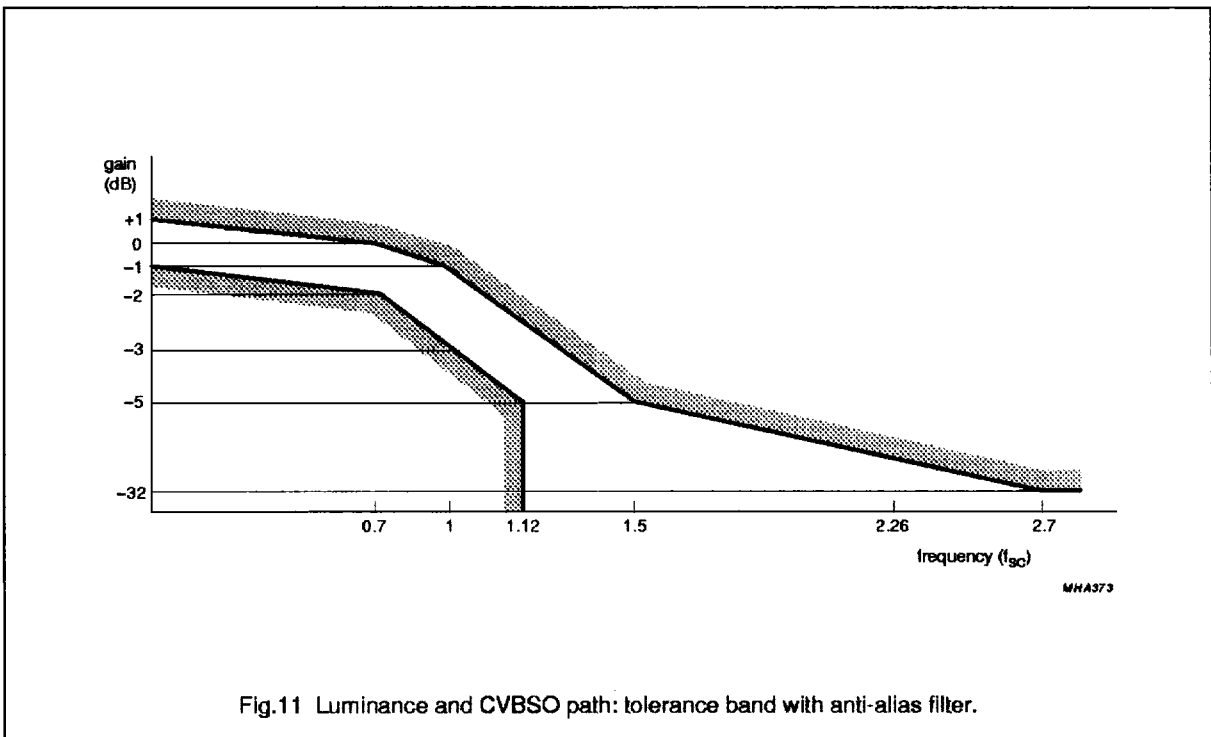
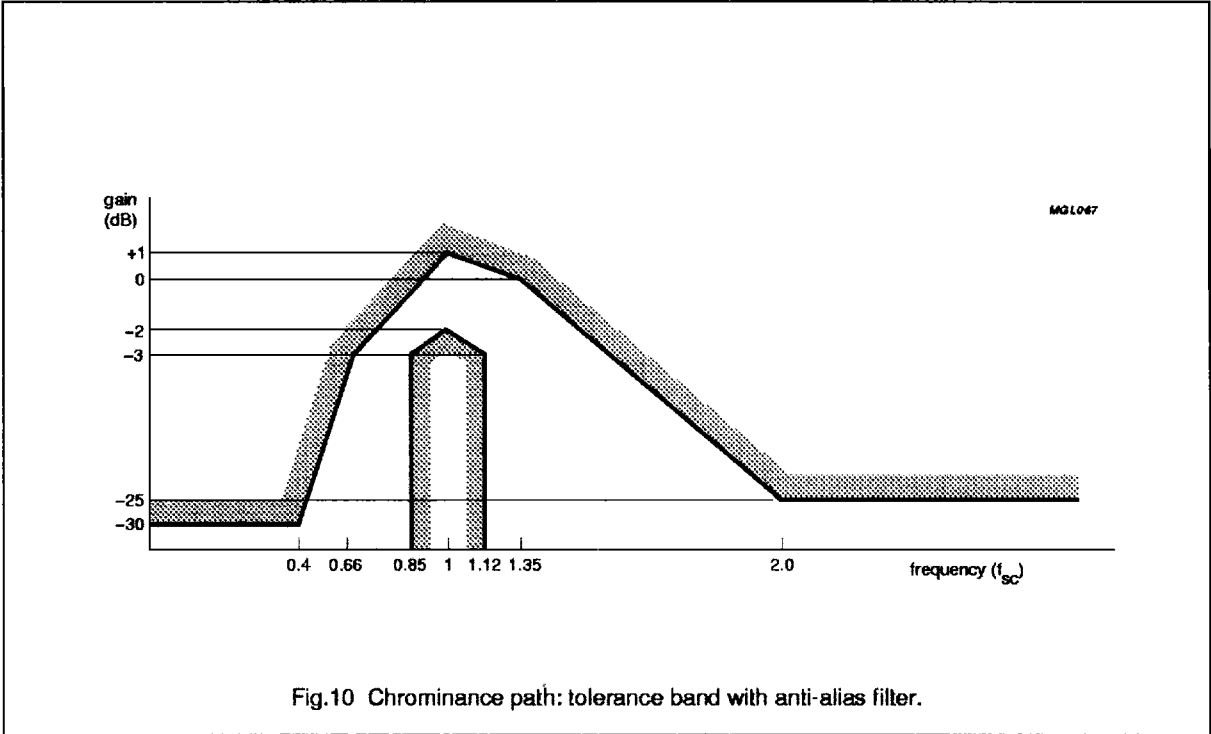

Fig.9 Clock control.

Integrated multistandard comb filter

SAA4961



Integrated multistandard comb filter

SAA4961

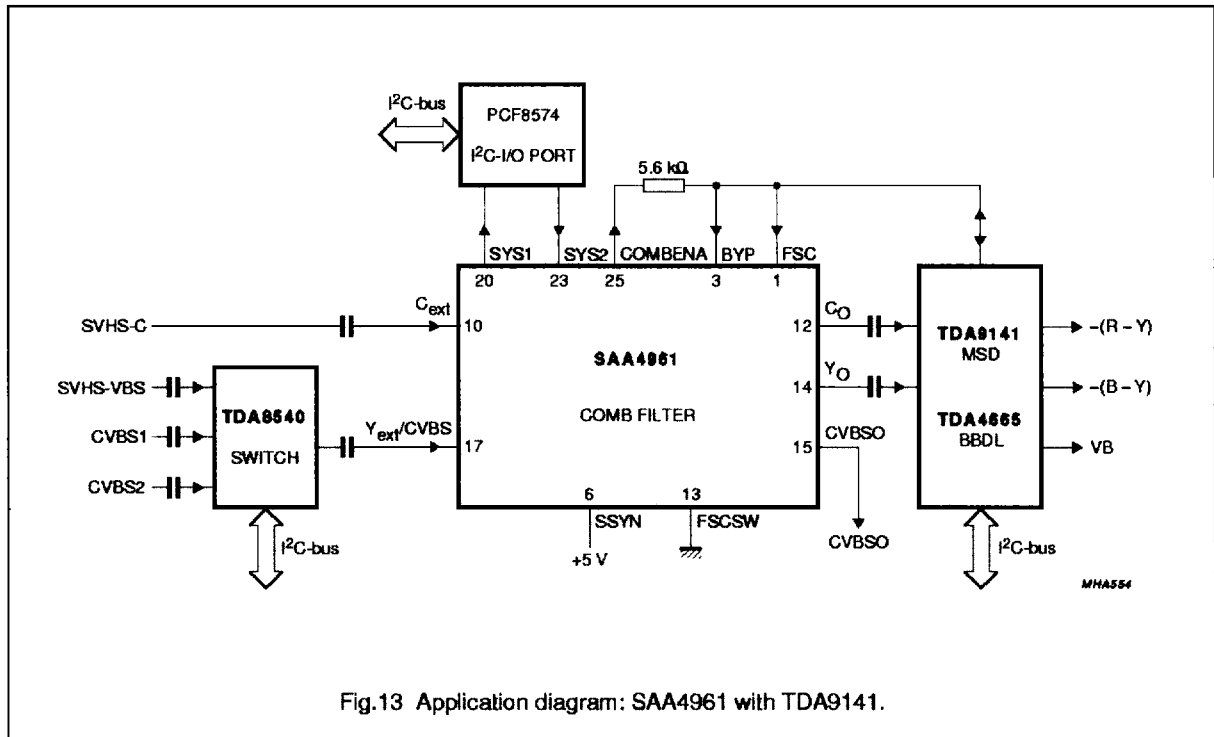

Fig.13 Application diagram: SAA4961 with TDA9141.

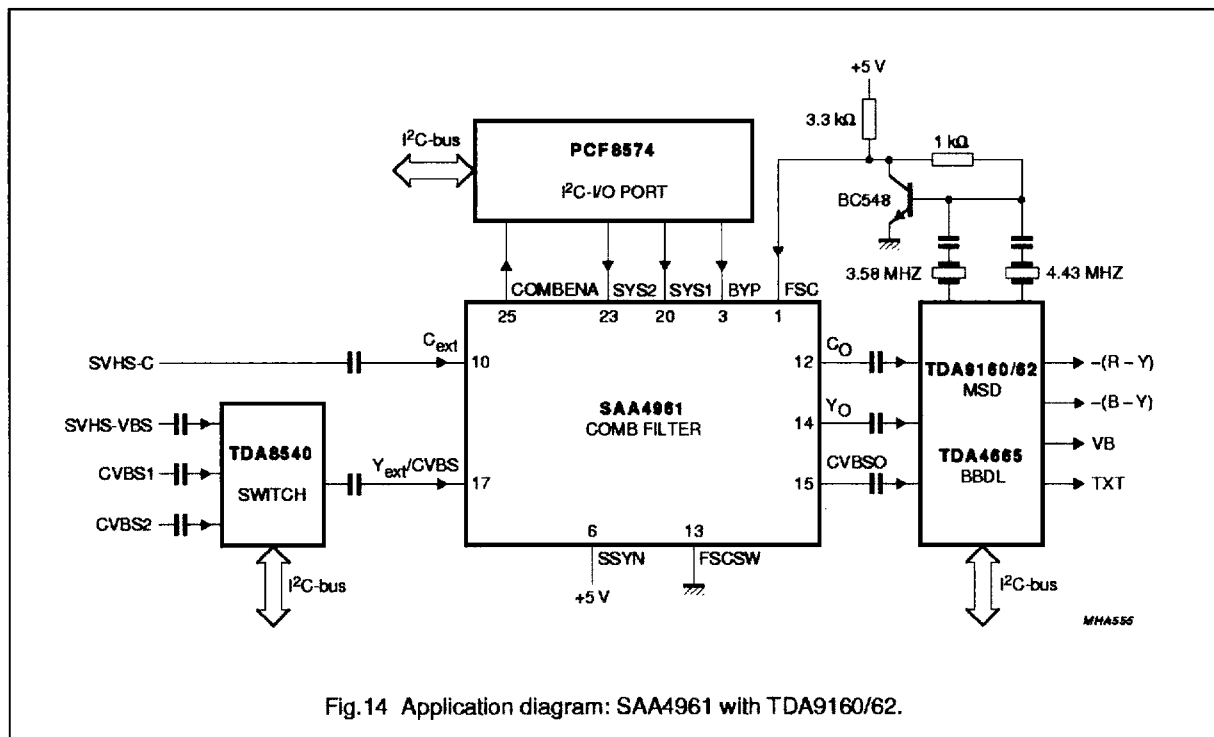
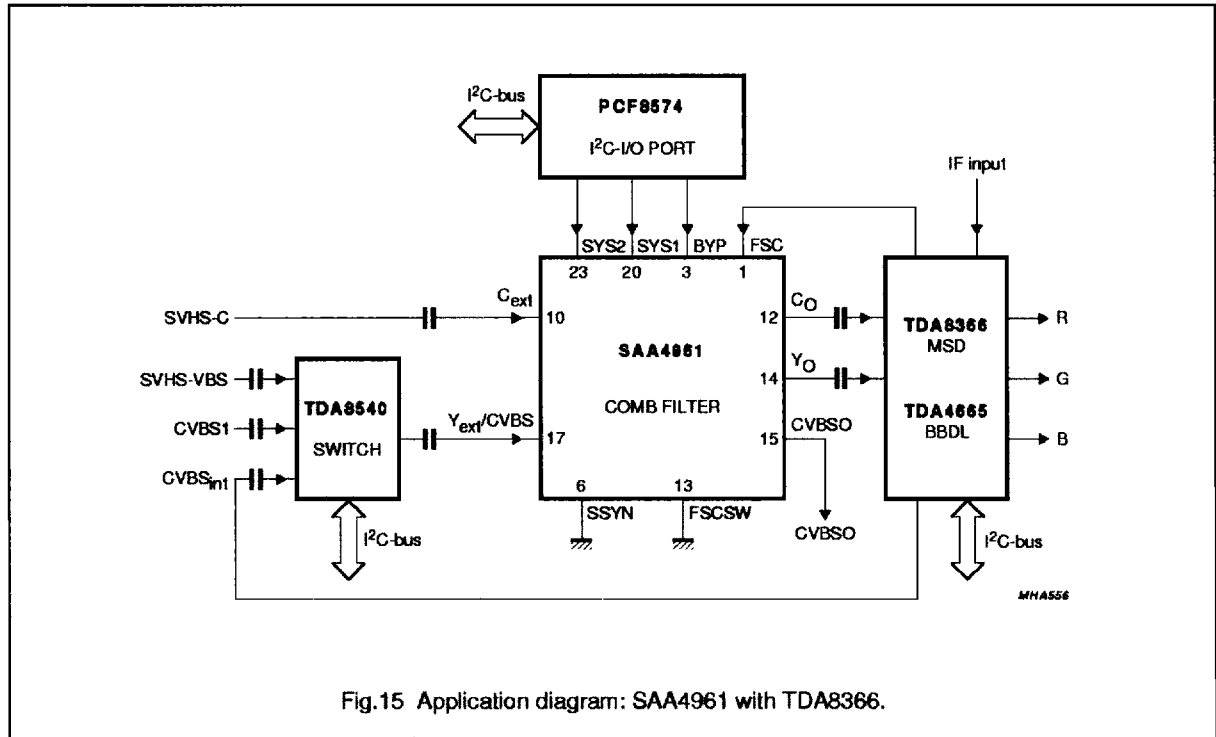

Fig.14 Application diagram: SAA4961 with TDA9160/62.

Integrated multistandard comb filter

SAA4961



Integrated multistandard comb filter

SAA4961

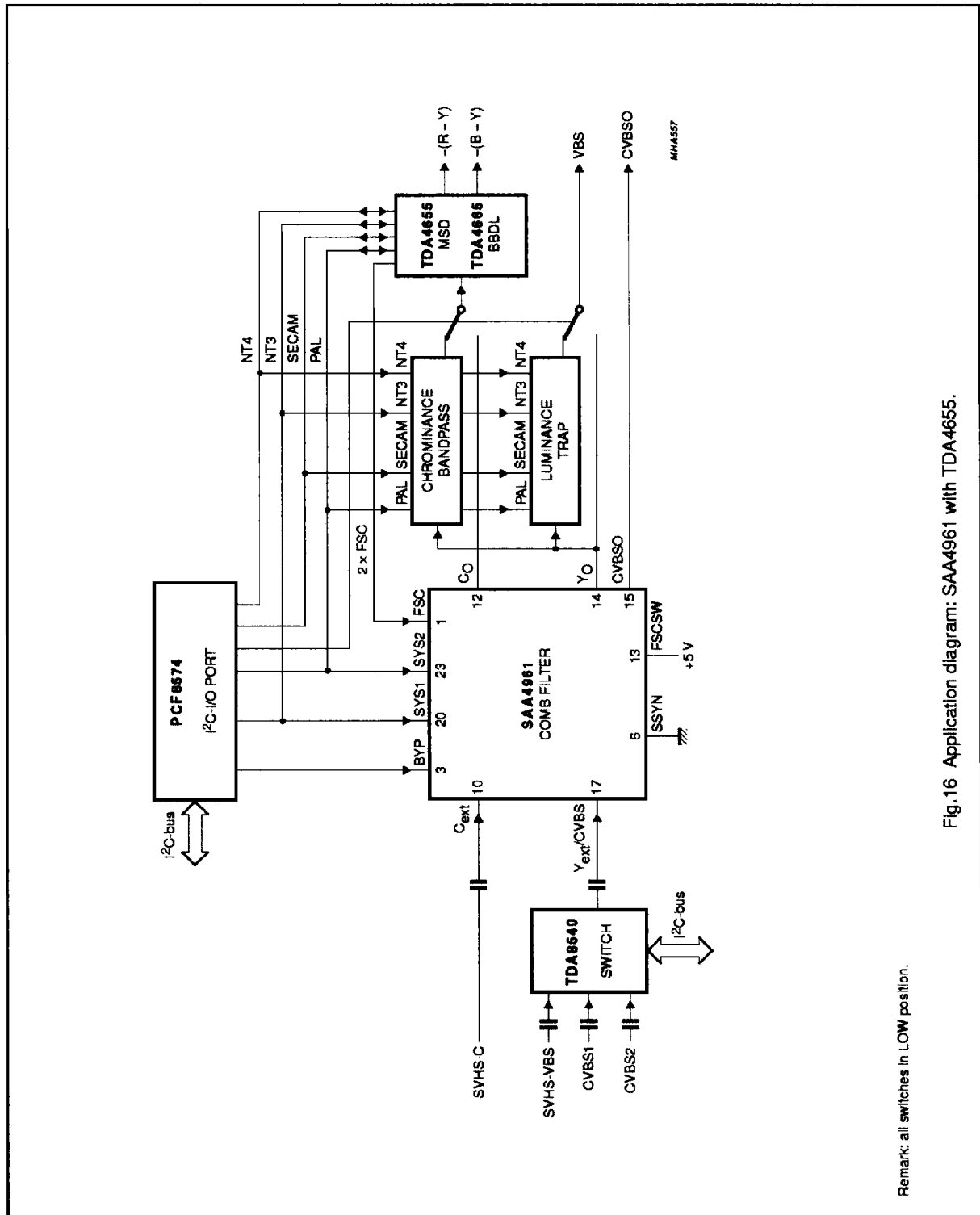

Fig.16 Application diagram: SAA4961 with TDA4655.

Remark: all switches in LOW position.

Integrated multistandard comb filter

SAA4961

PACKAGE OUTLINE

DIP28: plastic dual in-line package; 28 leads (600 mil)

SOT117-1

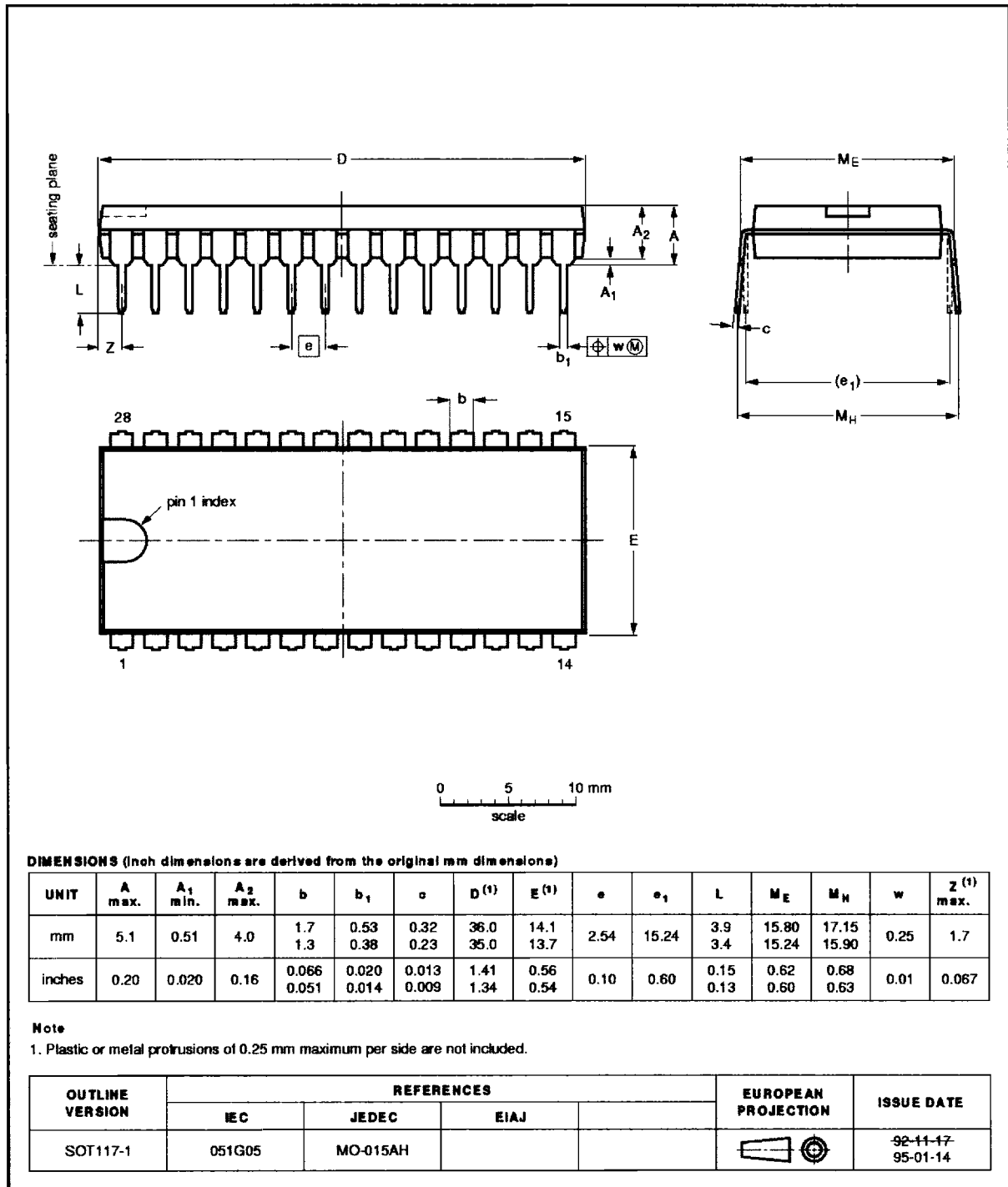

Integrated multistandard comb filter

SAA4961

SOLDERING

Introduction

There is no soldering method that is ideal for all IC packages. Wave soldering is often preferred when through-hole and surface mounted components are mixed on one printed-circuit board. However, wave soldering is not always suitable for surface mounted ICs, or for printed-circuits with high population densities. In these situations reflow soldering is often used.

This text gives a very brief insight to a complex technology. A more in-depth account of soldering ICs can be found in our "IC Package Databook" (order code 9398 652 90011).

Soldering by dipping or by wave

The maximum permissible temperature of the solder is 260 °C; solder at this temperature must not be in contact with the joint for more than 5 seconds. The total contact time of successive solder waves must not exceed 5 seconds.

The device may be mounted up to the seating plane, but the temperature of the plastic body must not exceed the specified maximum storage temperature ($T_{stg\ max}$). If the printed-circuit board has been pre-heated, forced cooling may be necessary immediately after soldering to keep the temperature within the permissible limit.

Repairing soldered joints

Apply a low voltage soldering iron (less than 24 V) to the lead(s) of the package, below the seating plane or not more than 2 mm above it. If the temperature of the soldering iron bit is less than 300 °C it may remain in contact for up to 10 seconds. If the bit temperature is between 300 and 400 °C, contact may be up to 5 seconds.

DEFINITIONS

Data sheet status	
Objective specification	This data sheet contains target or goal specifications for product development.
Preliminary specification	This data sheet contains preliminary data; supplementary data may be published later.
Product specification	This data sheet contains final product specifications.
Limiting values	
Limiting values given are in accordance with the Absolute Maximum Rating System (IEC 134). Stress above one or more of the limiting values may cause permanent damage to the device. These are stress ratings only and operation of the device at these or at any other conditions above those given in the Characteristics sections of the specification is not implied. Exposure to limiting values for extended periods may affect device reliability.	
Application information	
Where application information is given, it is advisory and does not form part of the specification.	

LIFE SUPPORT APPLICATIONS

These products are not designed for use in life support appliances, devices, or systems where malfunction of these products can reasonably be expected to result in personal injury. Philips customers using or selling these products for use in such applications do so at their own risk and agree to fully indemnify Philips for any damages resulting from such improper use or sale.

Integrated multistandard comb filter

SAA4961

NOTES

Integrated multistandard comb filter

SAA4961

NOTES

Philips Semiconductors – a worldwide company

Argentina: see South America

Australia: 34 Waterloo Road, NORTH RYDE, NSW 2113,
Tel. +61 2 9805 4455, Fax. +61 2 9805 4466

Austria: Computerstr. 6, A-1101 WIEN, P.O. Box 213,
Tel. +43 1 60 101, Fax. +43 1 60 101 1210

Belarus: Hotel Minsk Business Center, Bld. 3, r. 1211, Volodarski Str. 6,
220050 MINSK, Tel. +375 172 200 733, Fax. +375 172 200 773

Belgium: see The Netherlands

Brazil: see South America

Bulgaria: Philips Bulgaria Ltd., Energoproject, 15th floor,
51 James Bouchier Blvd., 1407 SOFIA,
Tel. +359 2 689 211, Fax. +359 2 689 102

Canada: PHILIPS SEMICONDUCTORS/COMPONENTS,
Tel. +1 800 234 7381

China/Hong Kong: 501 Hong Kong Industrial Technology Centre,
72 Tai Chee Avenue, Kowloon Tong, HONG KONG,
Tel. +852 2319 7888, Fax. +852 2319 7700

Colombia: see South America

Czech Republic: see Austria

Denmark: Prags Boulevard 80, PB 1919, DK-2300 COPENHAGEN S,
Tel. +45 32 88 2636, Fax. +45 31 57 1949

Finland: Sinikalliontie 3, FIN-02630 ESPOO,
Tel. +358 9 615800, Fax. +358 9 61580/xxx

France: 4 Rue du Port-aux-Vins, BP317, 92156 SURESNES Cedex,
Tel. +33 1 40 99 6161, Fax. +33 1 40 99 6427

Germany: Hammerbrookstraße 69, D-20097 HAMBURG,
Tel. +49 40 23 53 60, Fax. +49 40 23 536 300

Greece: No. 15, 25th March Street, GR 17778 TAVROS/ATHENS,
Tel. +30 1 4894 339/239, Fax. +30 1 4814 240

Hungary: see Austria

India: Philips INDIA Ltd, Shivsagar Estate, A Block, Dr. Annie Besant Rd.
Worli, MUMBAI 400 018, Tel. +91 22 4938 541, Fax. +91 22 4938 722

Indonesia: see Singapore

Ireland: Newstead, Clonskeagh, DUBLIN 14,
Tel. +353 1 7640 000, Fax. +353 1 7640 300

Israel: RAPAC Electronics, 7 Kehilat Saloniki St, TEL AVIV 61180,
Tel. +972 3 645 0444, Fax. +972 3 649 1007

Italy: PHILIPS SEMICONDUCTORS, Piazza IV Novembre 3,
20124 MILANO, Tel. +39 2 6752 2531, Fax. +39 2 6752 2557

Japan: Philips Bldg 13-37, Kohnan 2-chome, Minato-ku, TOKYO 108,
Tel. +81 3 3740 5130, Fax. +81 3 3740 5077

Korea: Philips House, 260-199 Itaewon-dong, Yongsan-ku, SEOUL,
Tel. +82 2 709 1412, Fax. +82 2 709 1415

Malaysia: No. 76 Jalan Universiti, 46200 PETALING JAYA, SELANGOR,
Tel. +60 3 750 5214, Fax. +60 3 757 4880

Mexico: 5900 Gateway East, Suite 200, EL PASO, TEXAS 79905,
Tel. +9-5 800 234 7381

Middle East: see Italy

Netherlands: Postbus 90050, 5600 PB EINDHOVEN, Bldg. VB,
Tel. +31 40 27 82785, Fax. +31 40 27 88399

New Zealand: 2 Wagener Place, C.P.O. Box 1041, AUCKLAND,
Tel. +64 9 849 4160, Fax. +64 9 849 7811

Norway: Box 1, Manglerud 0612, OSLO,
Tel. +47 22 74 8000, Fax. +47 22 74 8341

Philippines: Philips Semiconductors Philippines Inc.,
106 Valero St. Salcedo Village, P.O. Box 2108 MCC, MAKATI,
Metro MANILA, Tel. +63 2 816 6380, Fax. +63 2 817 3474

Poland: Ul. Lukiska 10, PL 04-123 WARSZAWA,
Tel. +48 22 612 2831, Fax. +48 22 612 2327

Portugal: see Spain

Romania: see Italy

Russia: Philips Russia, Ul. Usatcheva 35A, 119048 MOSCOW,
Tel. +7 095 755 6918, Fax. +7 095 755 6919

Singapore: Lorong 1, Toa Payoh, SINGAPORE 1231,
Tel. +65 350 2538, Fax. +65 251 6500

Slovakia: see Austria

Slovenia: see Italy

South Africa: S.A. PHILIPS Pty Ltd., 195-215 Main Road Marindale,
2092 JOHANNESBURG, P.O. Box 7430 Johannesburg 2000,
Tel. +27 11 470 5911, Fax. +27 11 470 5494

South America: Rua do Rocio 220, 5th floor, Suite 51,
04552-903 São Paulo, SÃO PAULO - SP, Brazil,
Tel. +55 11 821 2333, Fax. +55 11 829 1849

Spain: Balmes 22, 08007 BARCELONA,
Tel. +34 3 301 6312, Fax. +34 3 301 4107

Sweden: Kottbygatan 7, Akalla, S-16485 STOCKHOLM,
Tel. +46 8 632 2000, Fax. +46 8 632 2745

Switzerland: Almendstrasse 140, CH-8027 ZÜRICH,
Tel. +41 1 488 2686, Fax. +41 1 481 7730

Taiwan: Philips Semiconductors, 6F, No. 96, Chien Kuo N. Rd., Sec. 1,
TAIPEI, Taiwan Tel. +886 2 2134 2870, Fax. +886 2 2134 2874

Thailand: PHILIPS ELECTRONICS (THAILAND) Ltd.,
209/2 Sanpavuth-Bangna Road Prakanong, BANGKOK 10260,
Tel. +66 2 745 4090, Fax. +66 2 398 0793

Turkey: Talatpasa Cad. No. 5, 80640 GÜLTEPE/ISTANBUL,
Tel. +90 212 279 2770, Fax. +90 212 282 6707

Ukraine: PHILIPS UKRAINE, 4 Patrice Lumumba str., Building B, Floor 7,
252042 KIEV, Tel. +380 44 264 2776, Fax. +380 44 268 0461

United Kingdom: Philips Semiconductors Ltd., 276 Bath Road, Hayes,
MIDDLESEX UB3 5BX, Tel. +44 181 730 5000, Fax. +44 181 754 8421

United States: 811 East Arques Avenue, SUNNYVALE, CA 94088-3409,
Tel. +1 800 234 7381

Uruguay: see South America

Vietnam: see Singapore

Yugoslavia: PHILIPS, Trg N. Pasica 5/v, 11000 BEOGRAD,
Tel. +381 11 625 344, Fax. +381 11 635 777

For all other countries apply to: Philips Semiconductors, Marketing & Sales Communications,
Building BE-p, P.O. Box 218, 5600 MD EINDHOVEN, The Netherlands, Fax. +31 40 27 24825

Internet: <http://www.semiconductors.philips.com>

© Philips Electronics N.V. 1997

SCA53

All rights are reserved. Reproduction in whole or in part is prohibited without the prior written consent of the copyright owner.

The information presented in this document does not form part of any quotation or contract, is believed to be accurate and reliable and may be changed without notice. No liability will be accepted by the publisher for any consequence of its use. Publication thereof does not convey nor imply any license under patent- or other industrial or intellectual property rights.

Printed in The Netherlands

547047/1200/01/pp28

Date of release: 1997 Feb 03

Document order number: 9397 750 01688

Let's make things better.

Philips
Semiconductors



PHILIPS