

MS27477 Jam Nut Mount Hermetic Receptacle MIL-DTL-38999 Series II

How To Order: MS

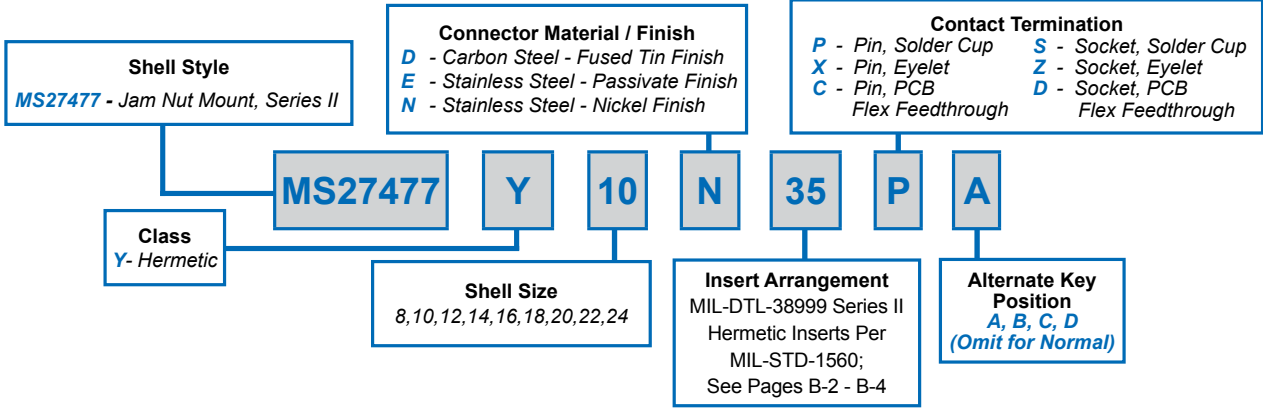

B

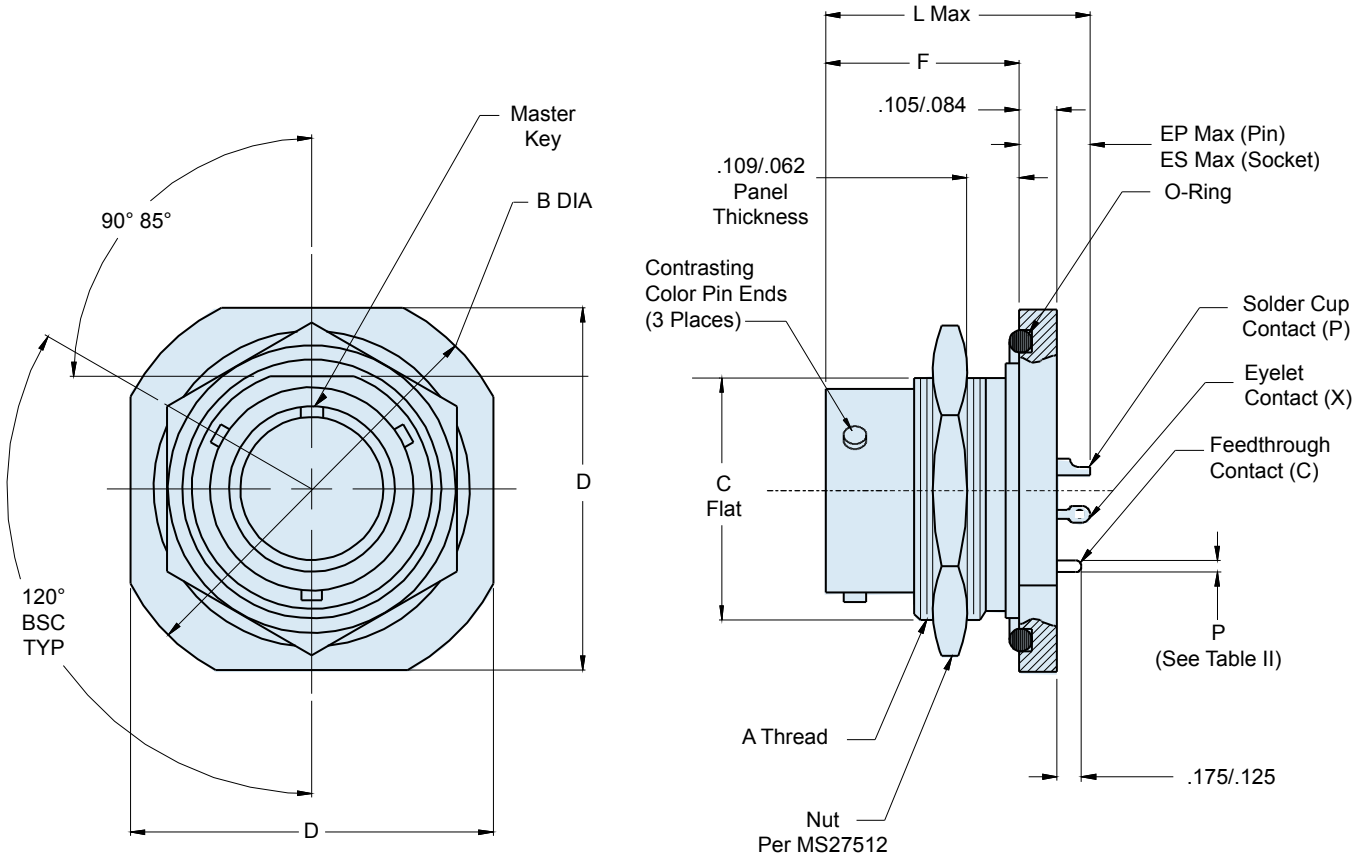

MS27477 Jam Nut Mount Hermetic Receptacle MIL-DTL-38999 Series II



D38999 QPL
Hermetics

How To Order: Commercial

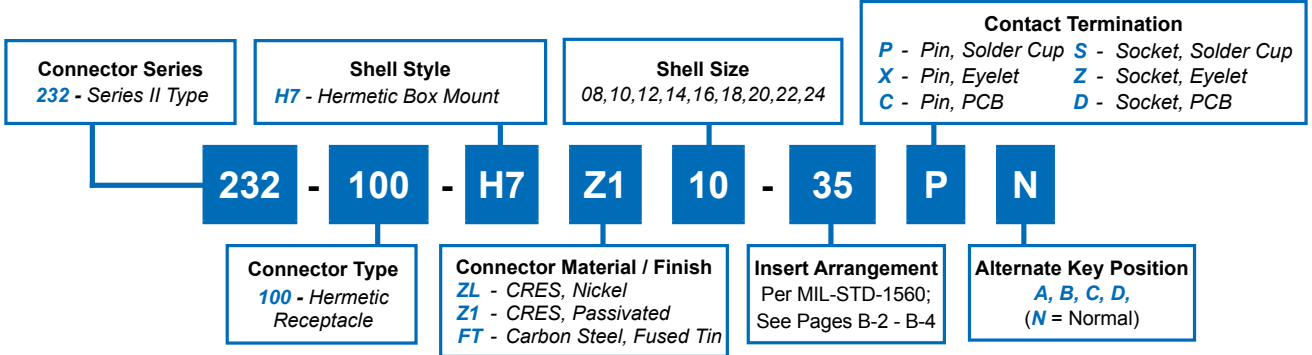

B

TABLE I: CONNECTOR DIMENSIONS				
SHELL SIZE	A THREAD CLASS 2A	B DIA ±.016(0.4)	C FLAT ±.004(0.1)	D A/F ±.016(0.4)
8/08	.875-20 UNEF	1.375(34.9)	.815(20.7)	1.25(31.8)
10	1.000-20 UNEF	1.5(38.1)	.939(23.9)	1.375(34.9)
12	1.125-18 UNEF	1.625(41.3)	1.063(27.0)	1.5(38.1)
14	1.250-18 UNEF	1.75(44.5)	1.188(30.2)	1.625(41.3)
16	1.375-18 UNEF	1.938(49.2)	1.318(33.5)	1.781(45.2)
18	1.500-18 UNEF	2.016(51.2)	1.438(36.5)	1.890(48.0)
20	1.625-18 UNEF	2.141(54.4)	1.563(39.7)	2.016(51.2)
22	1.750-18 UNS	2.265(57.5)	1.688(42.9)	2.140(54.4)
24	1.875-16 UN	2.39(60.7)	1.813(46.1)	2.265(57.5)

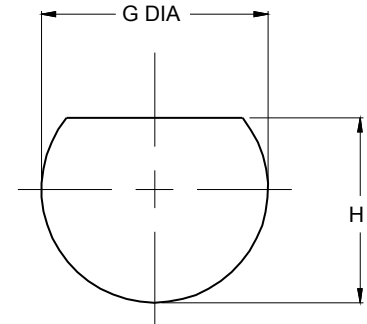

Recommended Panel Cut-Out

TABLE I (CONTINUED): CONNECTOR DIMENSIONS						
SHELL SIZE	EP MAX	ES MAX	F ±.005(0.1)	G DIA ±.005(0.1)	H ±.005(0.1)	L MAX
8/08	.281 (7.1)	.359 (9.1)	.438(11.1)	.889(22.6)	.828(21.0)	.724(18.4)
10	.281 (7.1)	.359 (9.1)	.438(11.1)	1.015(25.8)	.952(24.2)	.724(18.4)
12	.281 (7.1)	.359 (9.1)	.438(11.1)	1.139(28.9)	1.076(27.3)	.724(18.4)
14	.281 (7.1)	.359 (9.1)	.438(11.1)	1.264(32.1)	1.201(30.5)	.724(18.4)
16	.281 (7.1)	.359 (9.1)	.438(11.1)	1.389(35.3)	1.331(33.8)	.724(18.4)
18	.281 (7.1)	.359 (9.1)	.438(11.1)	1.515(38.5)	1.451(36.9)	.724(18.4)
20	.250 (6.4)	.344 (8.7)	.464(11.8)	1.640(41.7)	1.576(40.0)	.719(18.3)
22	.250 (6.4)	.344 (8.7)	.464(11.8)	1.745(44.3)	1.701(43.2)	.719(18.3)
24	.250 (6.4)	.344 (8.7)	.464(11.8)	1.890(48.0)	1.826(46.4)	.719(18.3)

TABLE II: CONTACT SIZE	
PRINTED CIRCUIT TAIL CONFIGURATIONS CONTACT STYLE C AND D	
SIZE 12 AND SIZE 16	
SIZE 22D AND SIZE 20	
Contact Size	ø P
22D	.011 (0.28) .015 (0.38)
20	.024 (0.61) .028 (0.71)
16	.0635 (1.61) .0615 (1.56)
12	.095 (2.41) .093 (2.36)