

Right-angle SMT type male connector for PCB
HDR-EA()LMYPG1-()()+

For PCB

Right-angle SMT

RoHS



● Configuration of product Part No.

HDR-EA () LMY P G1- () ()+

- | | |
|---------------------------------|-----------------------------------|
| ① Series name | ⑥ Lock screw |
| ② Contact pitch: 0.635 mm | Blank : None |
| ③ No. of contacts: 14 or 26 | SL : Provided |
| ④ Type of contact | ⑦ Length of lock screw |
| LMY: Right-angle SMT type, male | E: 6.6 (standard) |
| ⑤ Contact plating | K: 3.3 (for HDR-E () LPA-LS) |
| G1: 0.76 μm or more Gold plate | Compatible with B-to-B and B-to-C |

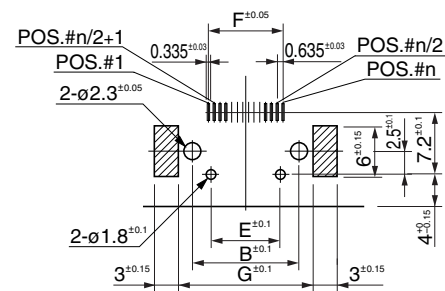
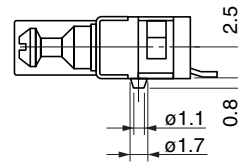
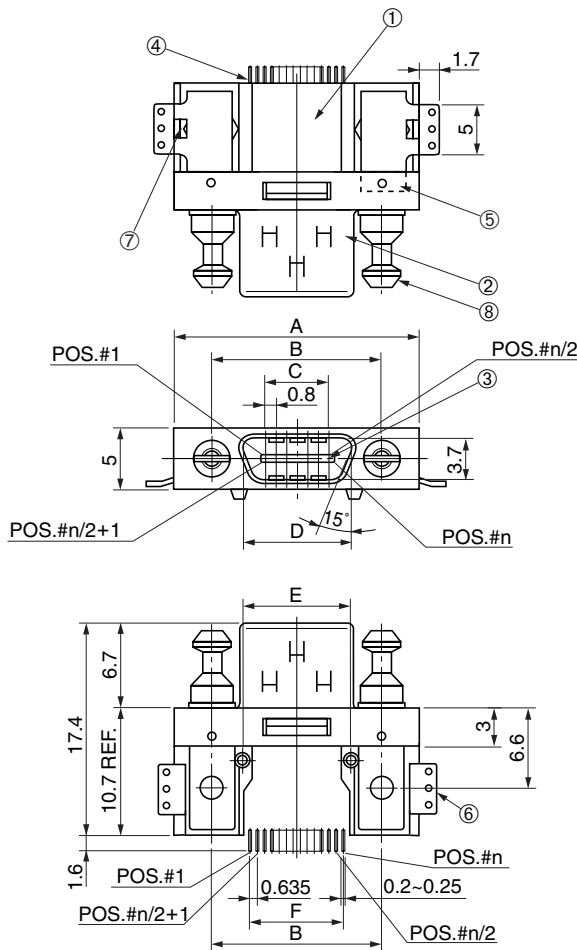

Recommended PCB layout : PAD

● Components

- | |
|---------------|
| ① Insulator A |
| ② Shell |
| ③ Contacts |
| ④ Insulator B |
| ⑤ Square nuts |
| ⑥ Hold down |
| ⑦ Hex nuts |
| ⑧ Lock screw |

● Dimensions

Part No.	A	B	C	D	E	F	G
HDR-EA14LMYPG1-()()+	20.0	14.4	4.8	9	9.2	8.255	19.0
HDR-EA26LMYPG1-()()+	24.8	19.2	9.6	13.8	14	15.875	23.8

Mating connector: HDR series IDC type or solder type female cable connector

For use with housing: -SLE: HDR series vertical housing

-SLK: HDR series vertical housing -LS, -LSA