

Amphenol



HDAS

High density PCB interconnects system for
harsh environments applications



HDAS

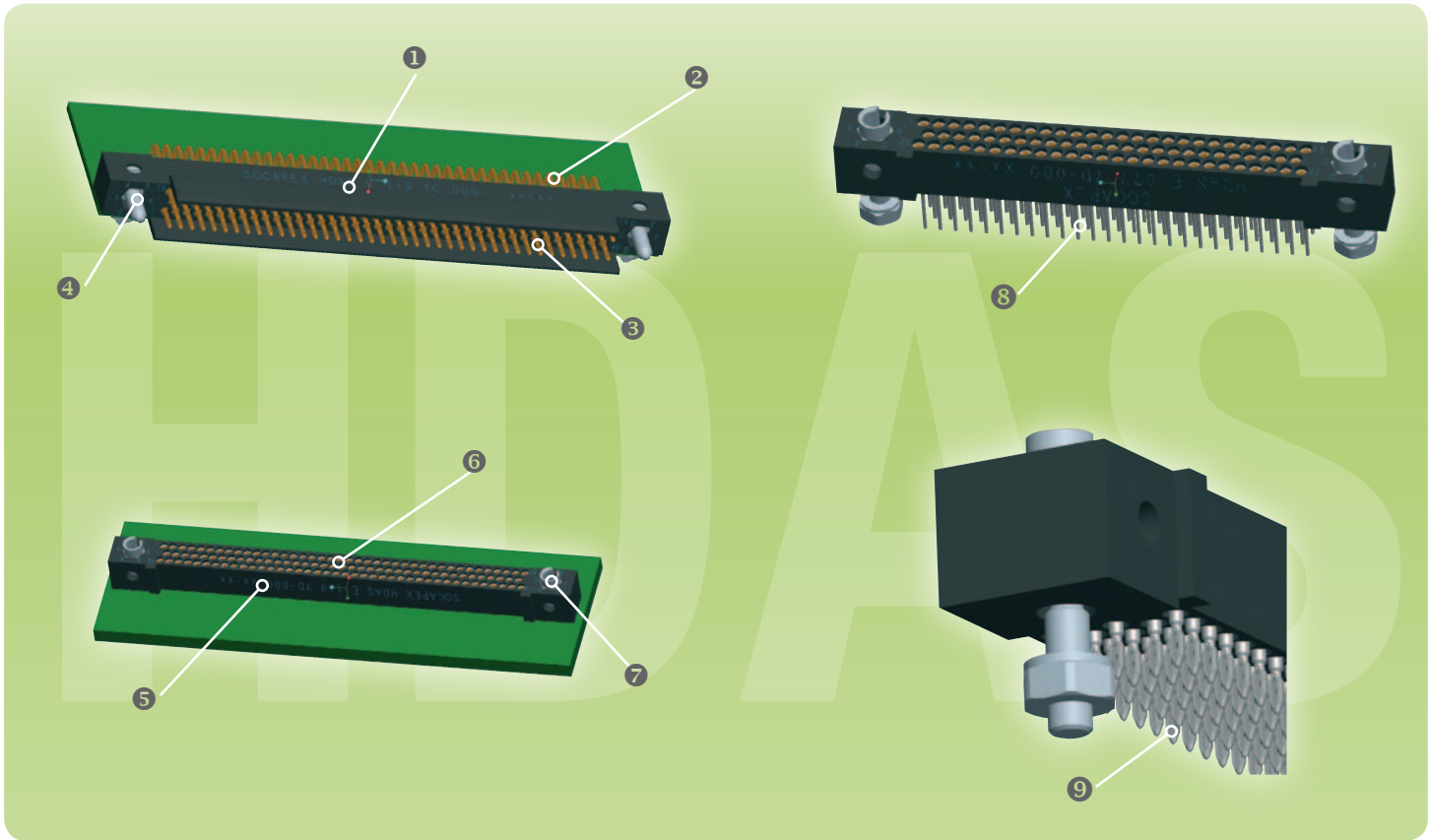

With its robust and simple design, its density, its high performances to extreme constraints, HDAS is the right connector to choose when installation costs and reliability must be mastered.

- ① - Black LCP male insulator
- ② - Right angle PC contact termination. For tru hole soldering.
- ③ - Male contact, mating end size 23 per MIL DTL 55302F
- ④ - Male codable guide. Lockable and/or different style upon request.
- ⑤ - Black LCP female insulator
- ⑥ - Female contact, mating end size 23 per MIL DTL 55302F
- ⑦ - Female codable guide. Lockable and/or different style upon request
- ⑧ - Straight PC contact termination. For thru hole soldering
- ⑨ - Press fit / Compliant pin contact termination for solderless assembly

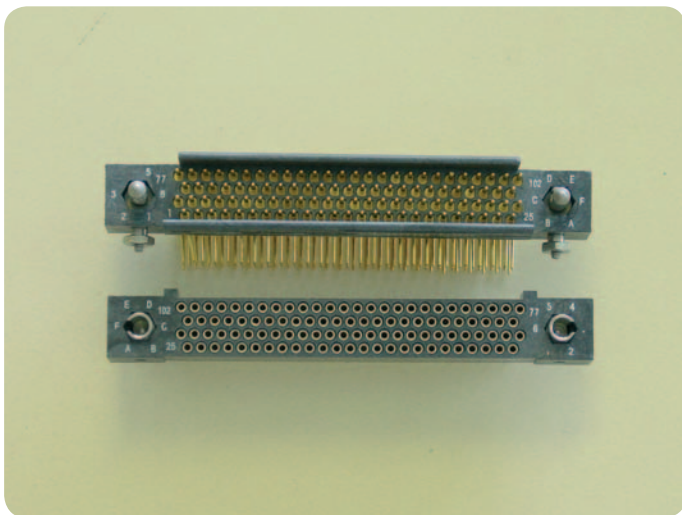



SCOPE

- Amphenol reduces the pitch and increases the density of contacts with the brand new HDAS range. 1,905 x 1,905mm staggered grid, from 3 to 6 rows.
- With the robust technology of the HDAS connectors, bring more reliability and more efficiency to your system, while minimizing the cost of installation.
- HDAS has passed and dramatically exceeded all the MIL DTL 55302F requirements, as well as the new demands of the military transportations.
- The press-fit technology, now available at Amphenol Socapex, allows to reduce significantly the costs of assembling on backplane, while ensuring extreme reliability even for the thickest motherboards. No more solder joints, pre-baking, cleaning...
- The coding devices are codable 6 times within their own cavities, i.e. 36 coding possibilities

per connector. They are directly inspired from our well known 127 series concept.

- The usage of LCP material authorizes all the types of soldering, including high temperature process for lead free requirement. All the HDAS is available in a fully RoHS compliant version.

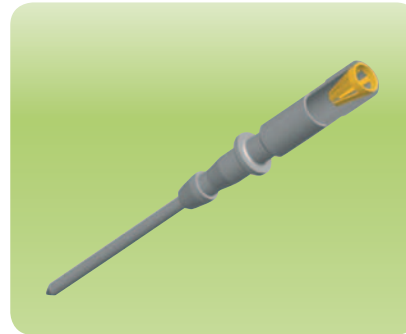

The starclip provides an excellent mechanical and electrical reliability, with its 6 contact lips.

- Amphenol Socapex introduces the cylindrical machined pins in its PCB connector, with the proven starclip technology of the socket. Size 23 permits a high average current, while an improved strength in regards of the traditional diameters.

The guiding devices allows a disalignment before mating of 0,9 max in both longitudinal and lateral directions.

The lateral skirts on the male connectors ensure an optimum protection of the contacts. The mechanical protection of the female contacts is inherent to their own design.

If necessary, Amphenol Socapex can offer miscellaneous terminations of contacts, such as solder cup for wires (tests), SMT soldering through flexible sculptured circuits, and different length of solder dip, according to your specific thickness of board, as well as the suitable fittings.

TECHNICAL DATA - MINIMUM PERFORMANCES

ENVIRONMENTAL CHARACTERISTICS

- **Salt Spray:** 96H
- **Vibrations:** No discontinuity greater than 2ns during the following tests:
 - Sinus Vibrations per MIL STD 1344A Meth 2005 condition III:
 - 4 hours per axis in 3 axis – 10 to 65 Hz: 0,06 inch / 65 to 2000 Hz: 15g peak
 - Vibrations according to AIRBUS A400M specifications
 - M00RP0400432 rev.B, § 2.2.8.1 and MIL-STD-810F Cat 13 localisation 2:
 - 5-2000 Hz – 0,5g – 1 oct/min
 - ½ hour: 10,5g eff
 - 3 hours endurance
 - ½ hour 10,5 geff
- Shocks per MIL STD 1344A meth 2004 condition G – Sawtooth in – directions / 100g / 6ms each
- **Temperature cycling:** -65/+ 125°C
- 500 mating / unmating cycles

ELECTRICAL CHARACTERISTICS

- Contact resistance: 10 mohms maxi
- Dielectric withstanding voltage: 800 Veff mini
- Insulation resistance: 5 Gohm mini
- Current rating / contact: 4,5 A

MATERIAL DATA

- **Housings:** LCP Thermoplastic, 30% glass fiber filled.
- **Male contact:** Brass alloy machined alloy, with gold over nickel plating.
- **Female contacts housing:** Brass alloy machined alloy, with tin lead or lead free plating. Press-fit terminations are tin lead plated, according to ammendment N° C(2005)-4054 of the 2002/95/EC directive, relative to lead presence in electronic equipments.

- **Clip:** CuBe2, with gold over Nickel plating.
- **Guiding devices:** Brass Alloy, with electroless nickel plating.

All the hereabove platings are in accordance with the MIL-DTL-55302F specifications.



DRAWINGS SECTION

MOTHER BOARD HDAS E 77 YD-000

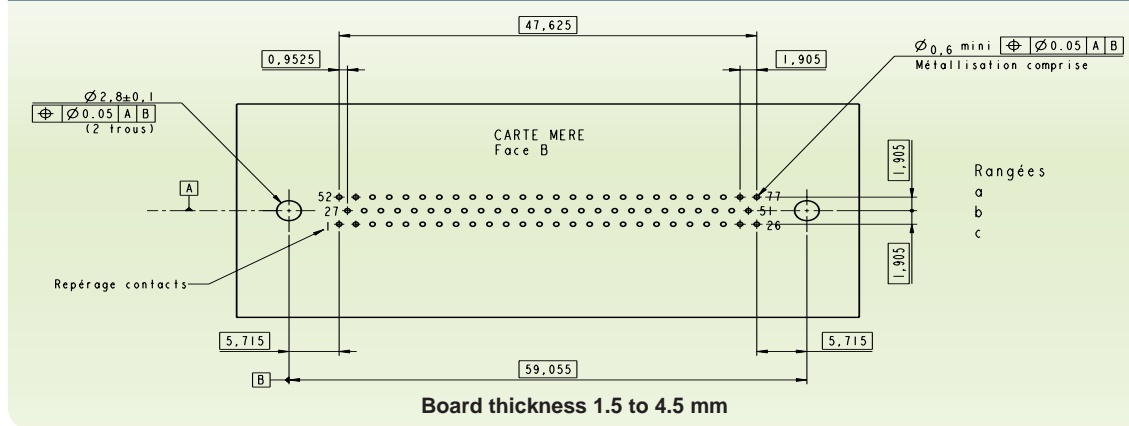

Please note that the dimensions on this page highlight a configuration with 77 contacts in 3 rows.

OVERALL DIMENSIONS HDAS E 77 YD-000

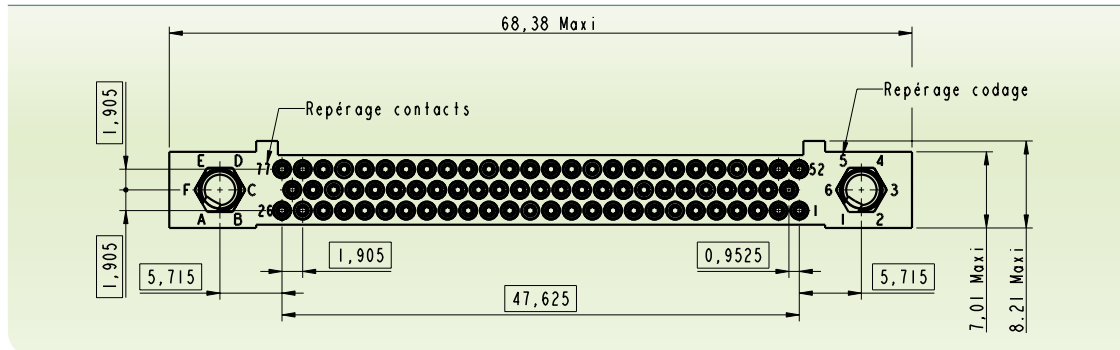

DAUGHTER BOARD HDAS F 77 YC-000

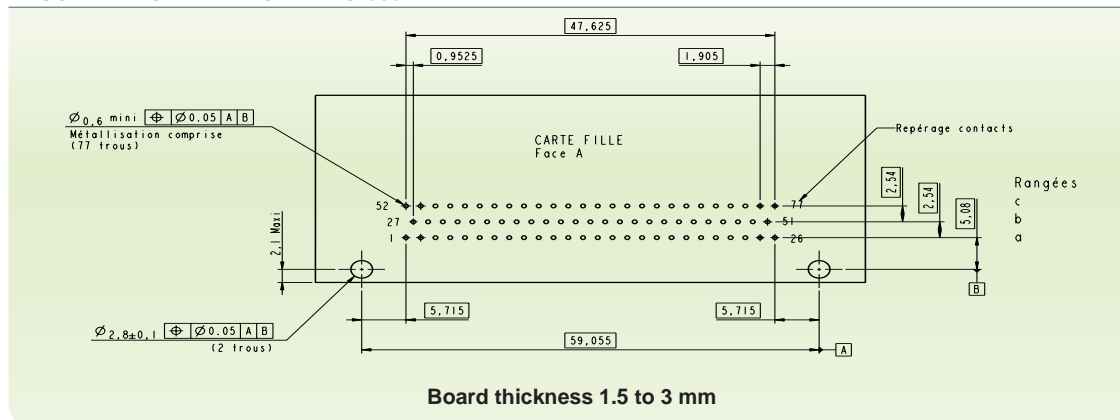

OVERALL DIMENSIONS HDAS F 77 YC-000

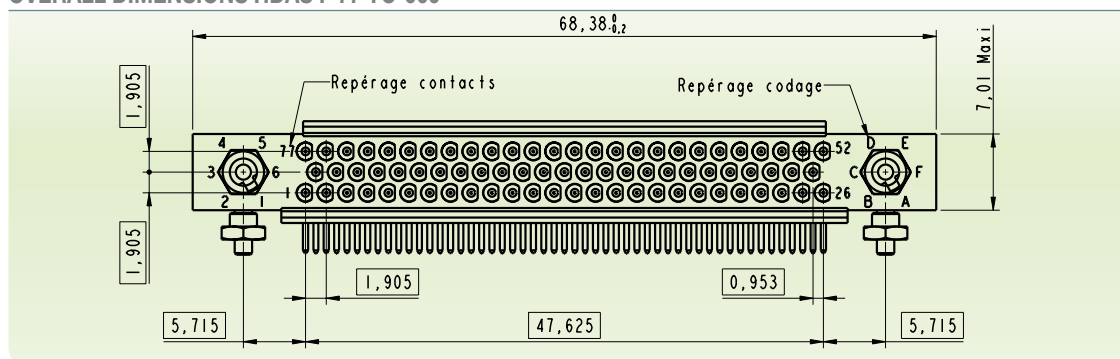



DAUGHTER BOARD HDAS F 102 YC-000

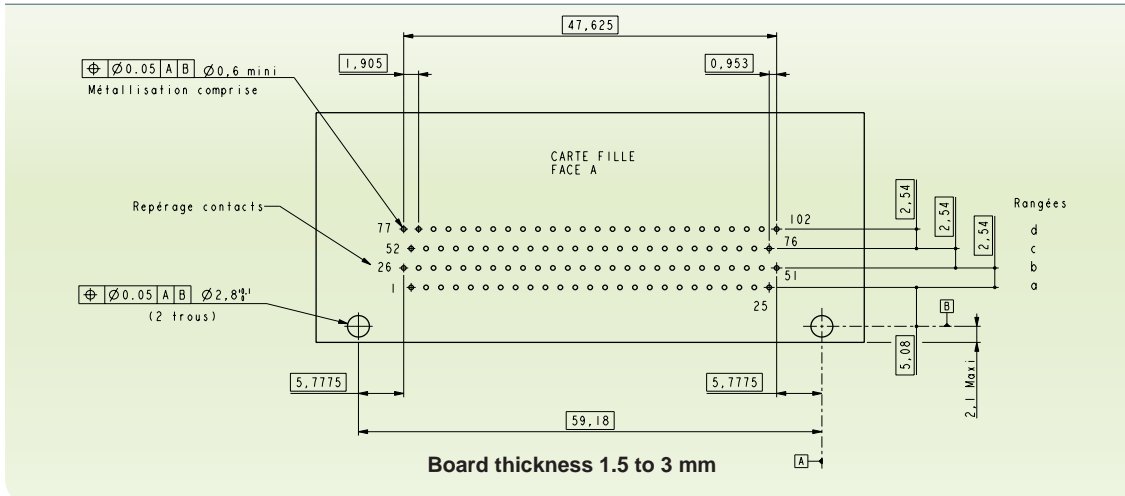

! 102

Please note that the dimensions on this page highlight a configuration with 102 contacts in 4 rows.

OVERALL DIMENSIONS HDAS F 102 YC-000

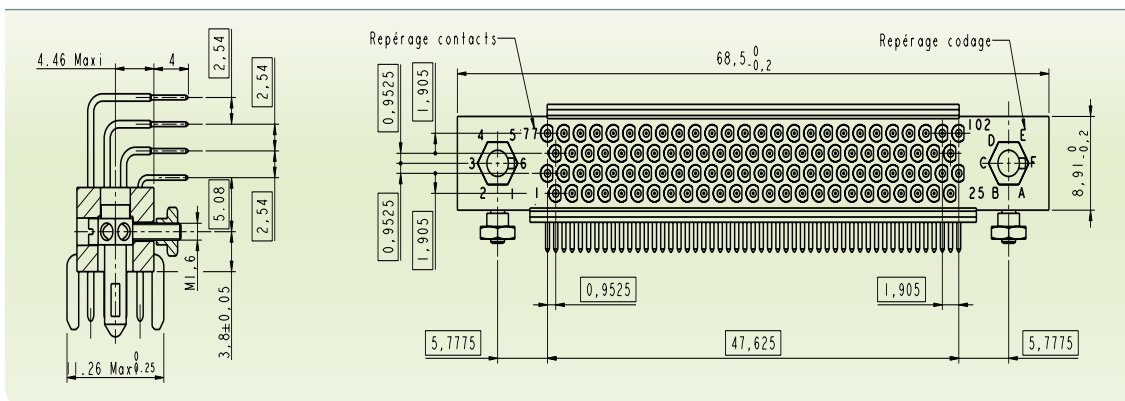

MOTHER BOARD HDAS E 102 YD-000 & HDAS F 102 YD-000

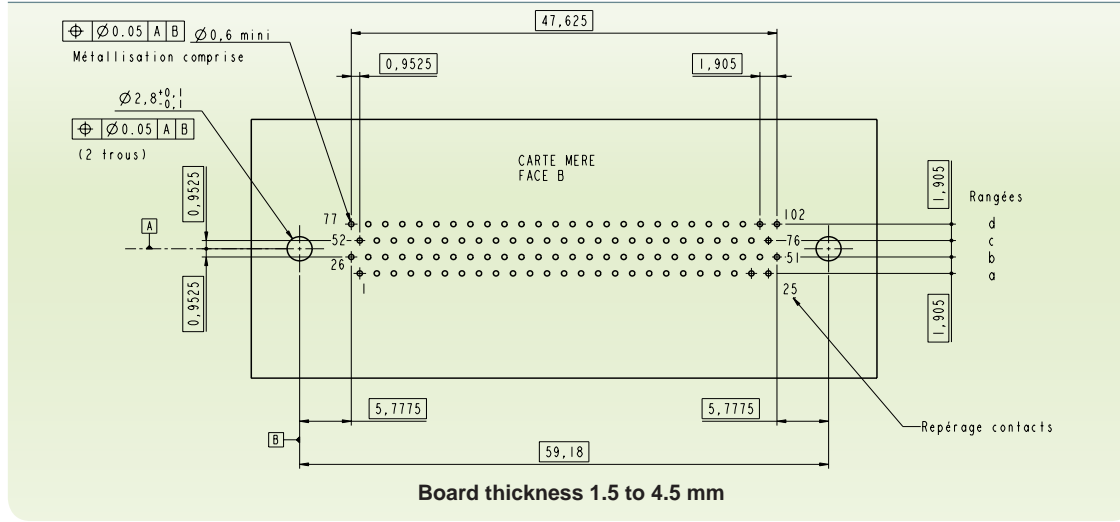

102

Please note that the dimensions on this page highlight a configuration with 102 contacts in 4 rows.

OVERALL DIMENSIONS HDAS E 102 YD-000

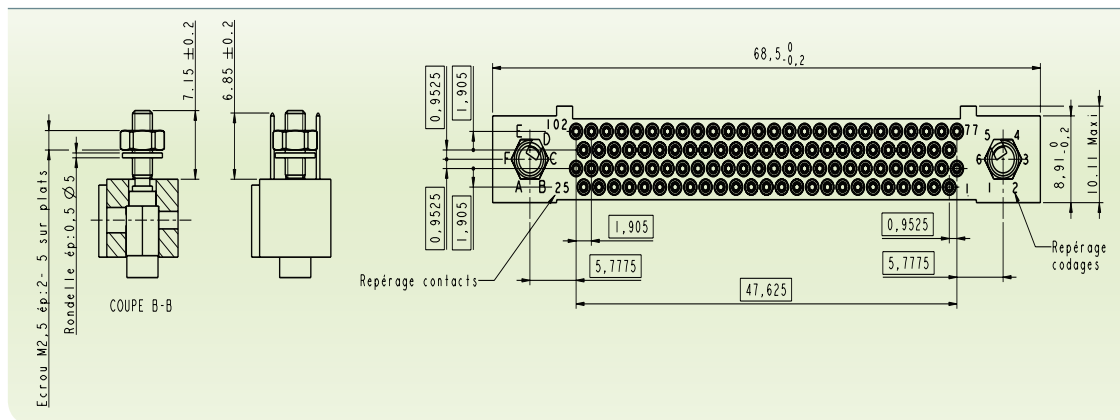



MOTHER BOARD HDAS E 119 YD-000

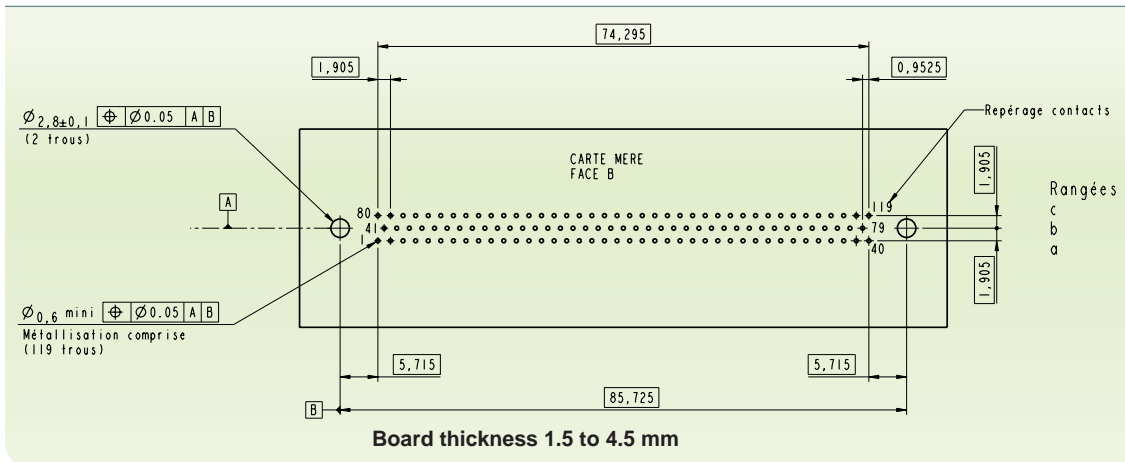

! 119
Please note that the dimensions on this page highlight a configuration with 119 contacts in 3 rows.

OVERALL DIMENSIONS HDAS E 119 YD-000

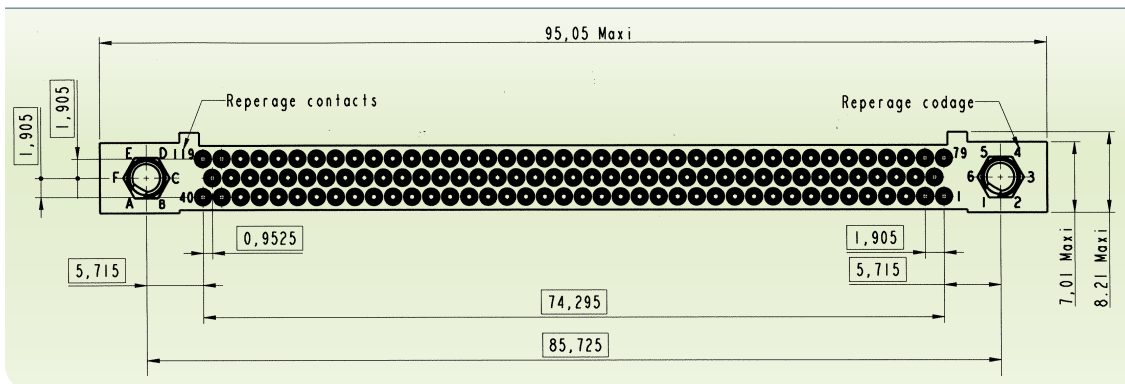



DAUGHTER BOARD HDAS F 119 YC-000

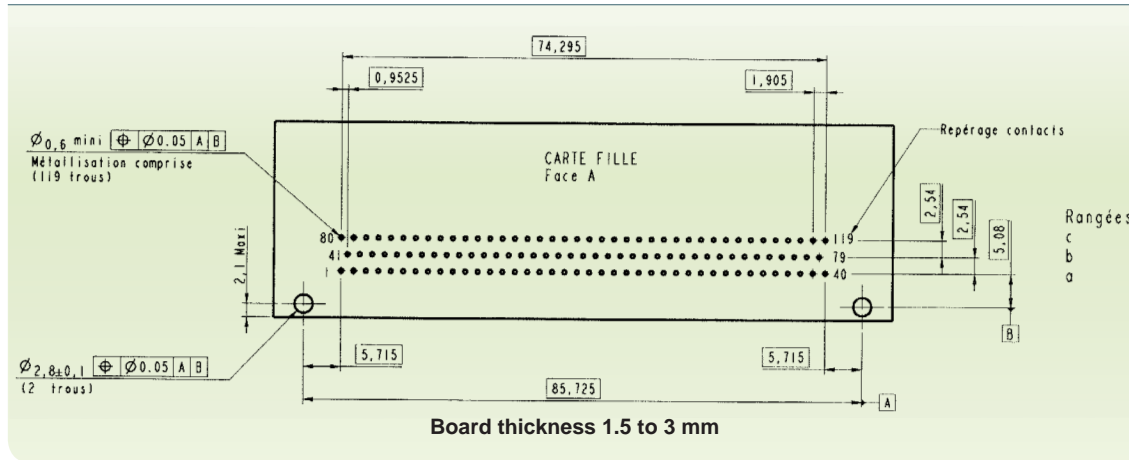

! 119

Please note that the dimensions on the left highlight a configuration with 119 contacts in 3 rows.

OVERALL DIMENSIONS HDAS F 119 YC-000

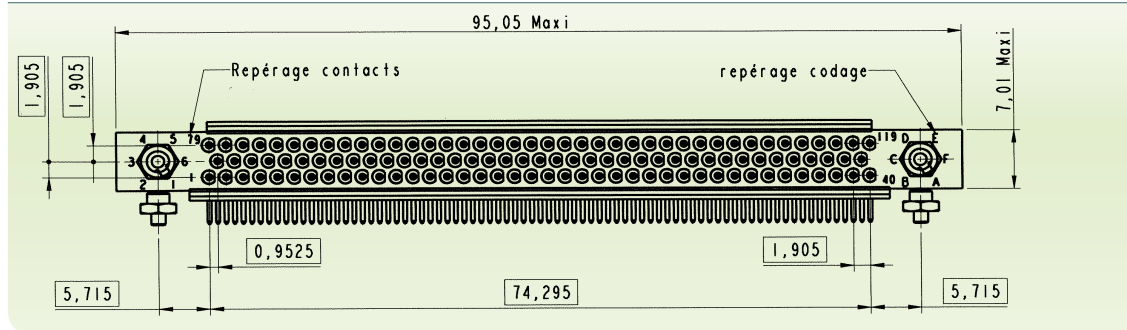

DAUGHTER BOARD HDAS E 202 YD-000 & F 202 YD 000

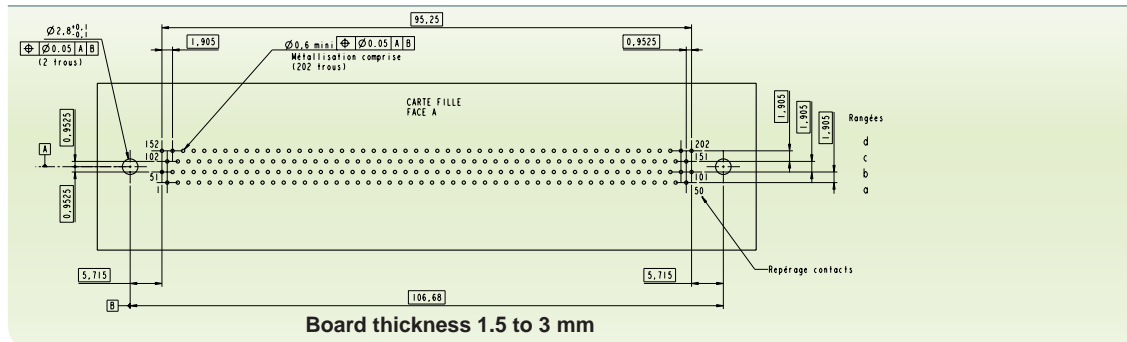

! 202

Please note that the dimensions on the left highlight a configuration with 202 contacts in 4 rows.

OVERALL DIMENSIONS HDAS E 202 YD-000

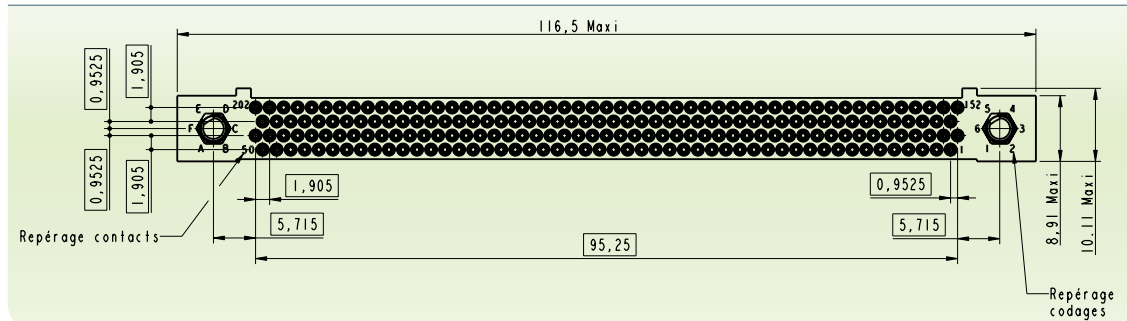



DAUGHTER BOARD HDAS F 202 YC-000 & HDAS F 202 YD-000

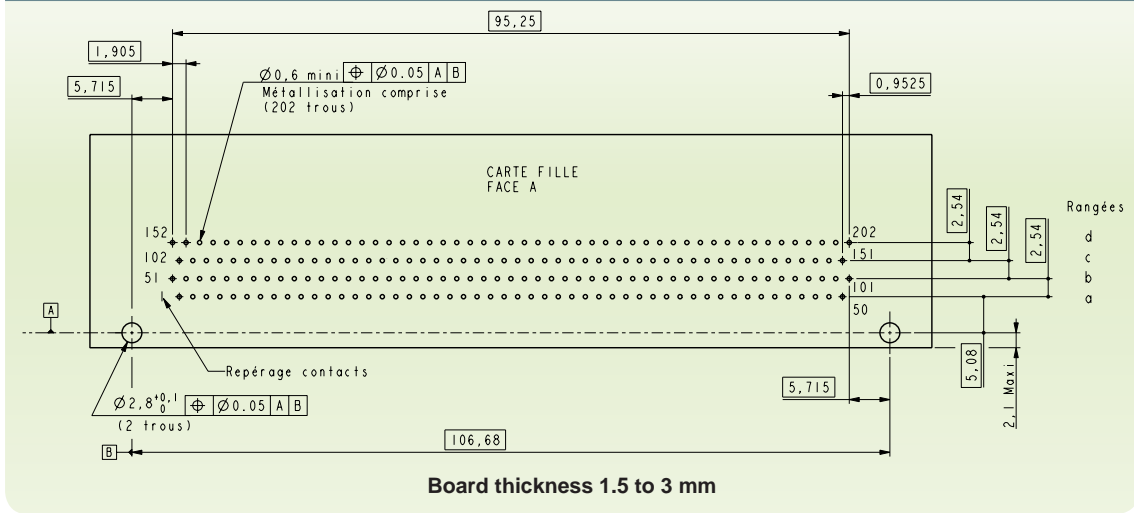

202
Please note that the dimensions on this page highlight a configuration with 202 contacts in 4 rows.

DAUGHTER BOARD HDAS F 202 YC-000

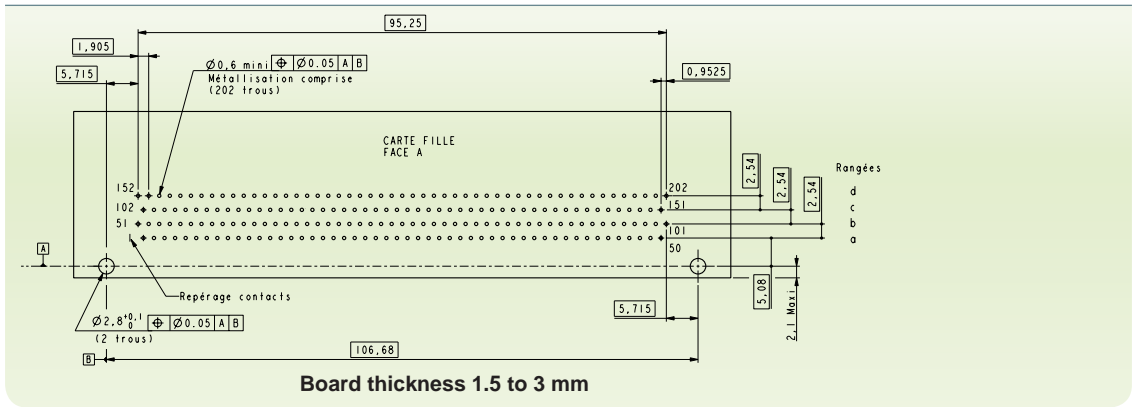

OVERALL DIMENSIONS HDAS F 202 YC-000

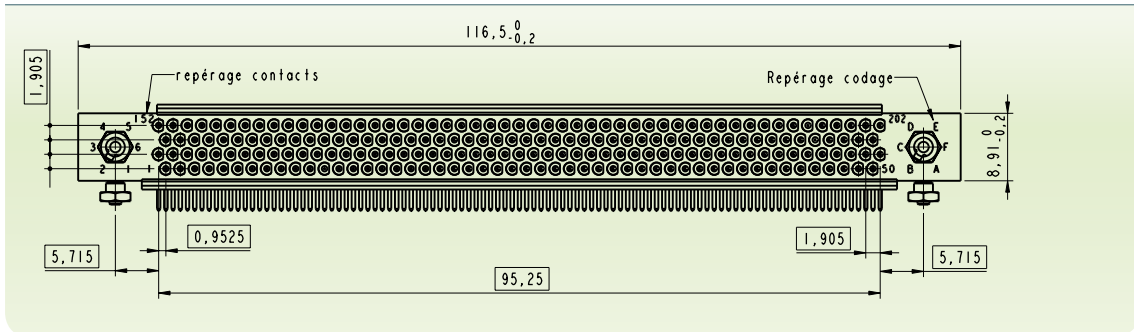



DAUGHTER BOARD HDAS E 253 YD-000 & F 253 YD 000

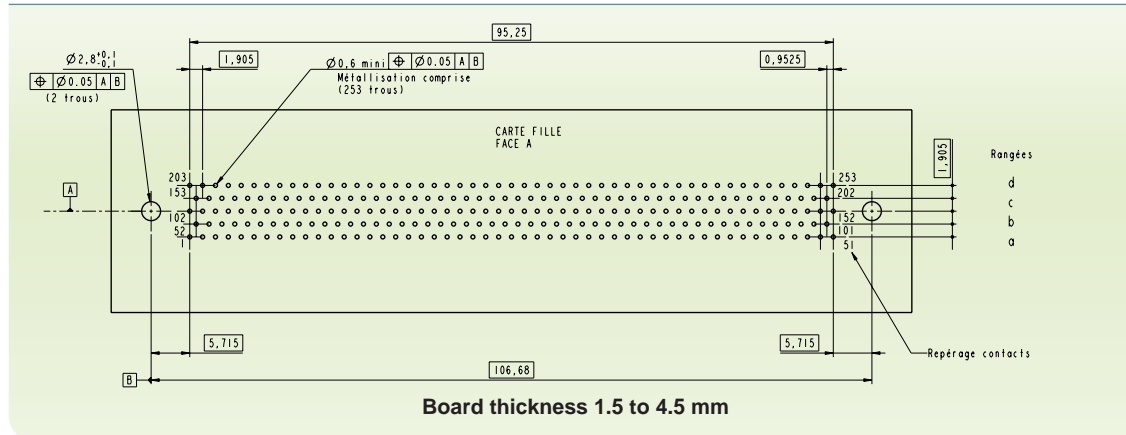

⚠️ 253

Please note that the dimensions on this page highlight a configuration with 253 contacts in 4 rows.

OVERALL DIMENSIONS HDAS E 253 YD-000

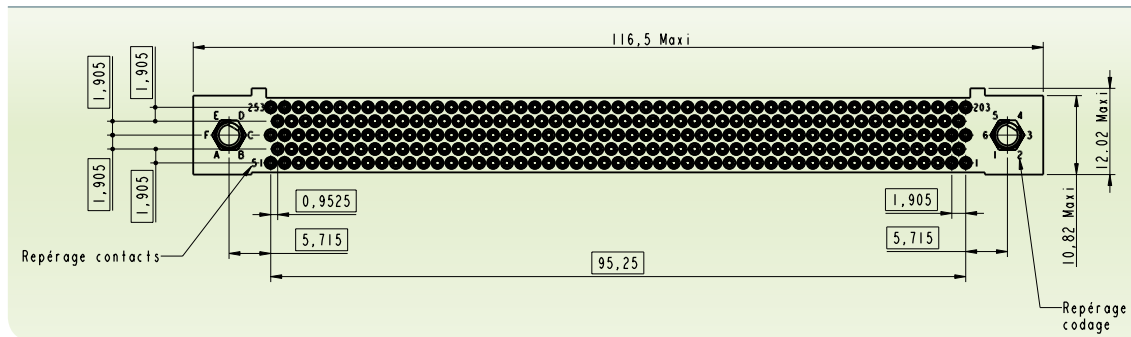

DAUGHTER BOARD HDAS F 253 YC-000

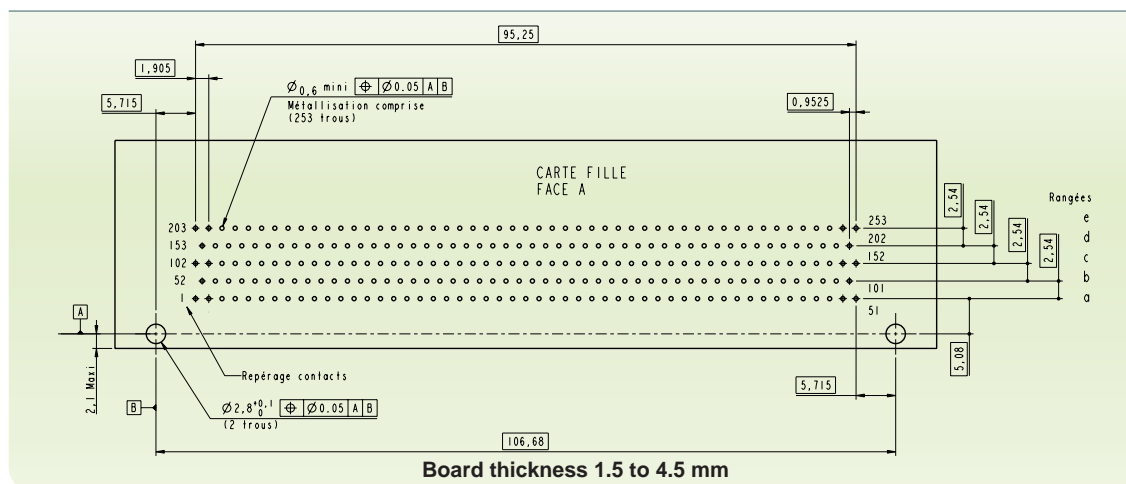

OVERALL DIMENSIONS HDAS F 253 YC-000

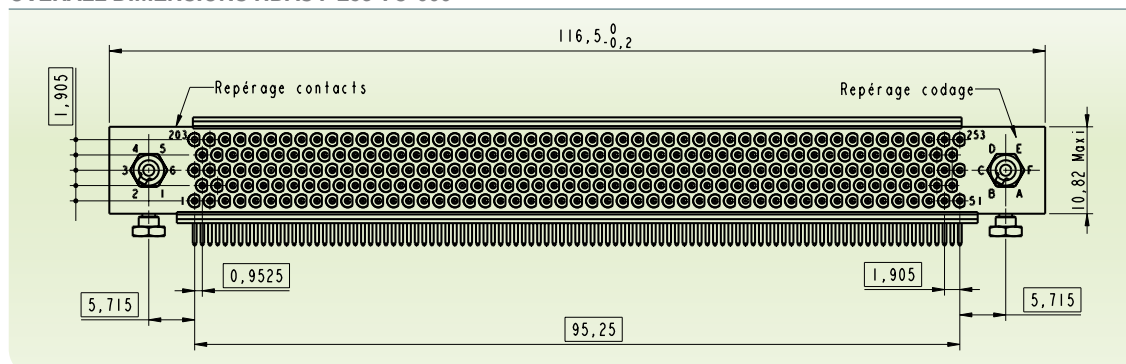



MOTHER BOARD HDAS E 253 YP-000

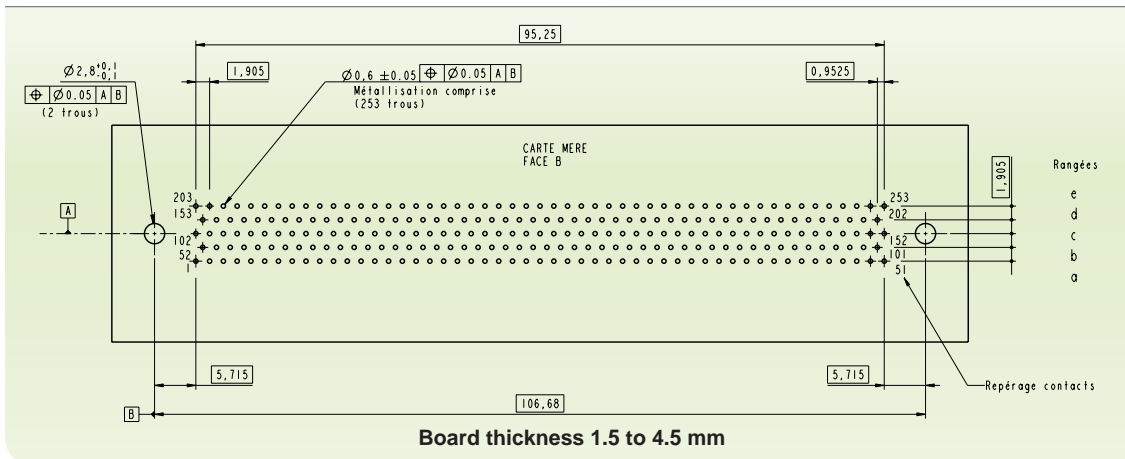

! 253

Please note that the dimensions on this page highlight a configuration with 253 contacts in 4 rows.





HDAS

DESIGNATION - HOW TO ORDER

Serie	HDAS	F	-	YC	-000
E: Female receptacle F: Male Plug					
Number of signals contacts 50 - 77 - 102 - 119 - 152 - 202 - 253 - 303					
YC for right angle PC tail YD for straight PC tail YP for press fit termination					
Deviations : -000: standards -XXX: for specific please consult us					

50 - 77 - 119 - 152 - 303 : soon available

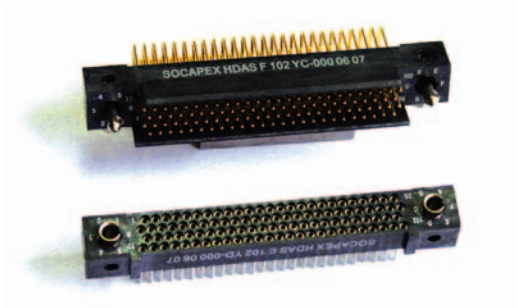

Do not hesitate to contact us for any additional information:



Amphenol Socapex

Olivier GAVARD – Product Manager

Tel : + 33 4 50 89 28 11

Cell: + 33 6 82 83 45 73

Email: olivier.gavard@amphenol-socapex.fr

Your local Contact:

Amphenol

The information given in this document are as a guideline only.
We reserve the right to modify our products in any way we deem necessary.
Any duplication is prohibited, unless approved in writing.
Realisation: wanagen:studios - Steven Kigallon - 08/2006

DOC-000067-ANG/A

For more information, please visit our websites:
www.amphenol-socapex.com