



# LED SPECIFICATION

Part No.: 599LW7C



**ATTENTION**  
OBSERVE PRECAUTIONS  
FOR HANDLING  
ELECTROSTATIC  
DISCHARGE  
SENSITIVE  
DEVICES

## Features:

- Single color
- High bright output
- Low power consumption
- High reliability and long life

## Descriptions:

- Dice material: GaInN
- Emitting Color: Super Bright White
- Device Outline:  $\phi$  5mm Round Flat Type
- Lens Type: Water Clear

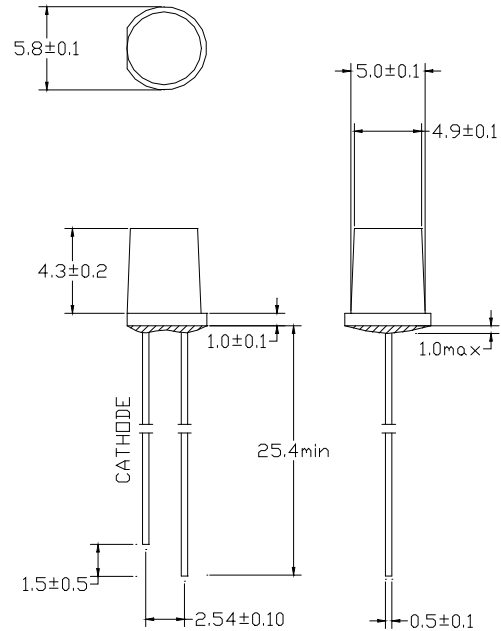

## NOTE:

- All dimensions are millimetres.
- Tolerance is +/-0.25mm unless otherwise noted

## HALF LIGHT PATTERN:

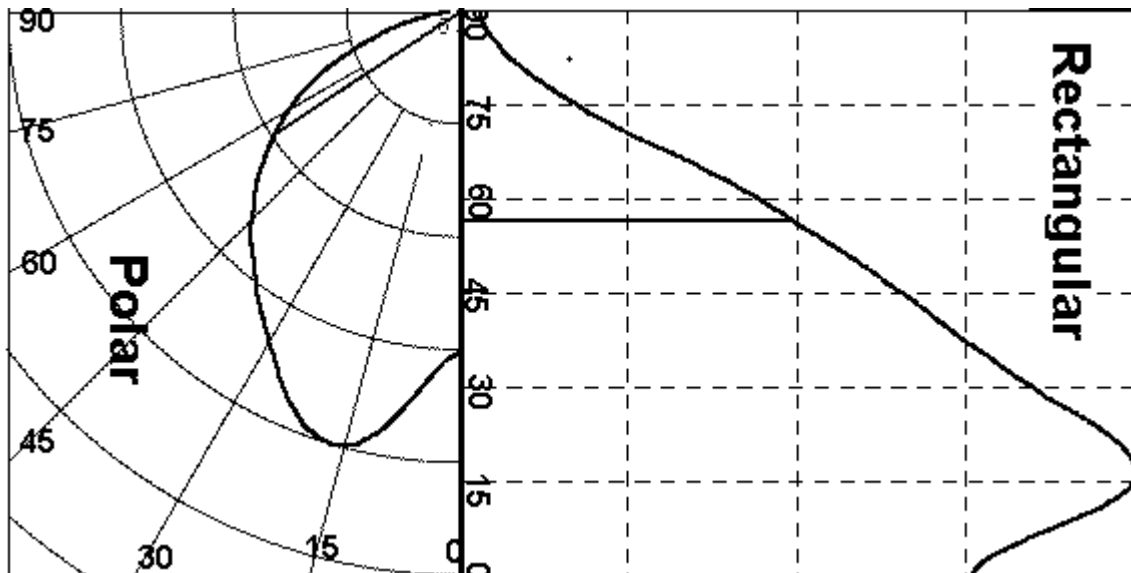



# LED SPECIFICATION

**Part No.:** 599LW7C

## **Absolute maximum ratings (Ta = 25°C)**

Parameter	Symbol	Test Condition	Value		Unit
			Min.	Max.	
Reverse Voltage	V <sub>R</sub>	I <sub>R</sub> = 30 μA	5	--	V
Forward Current	I <sub>F</sub>	----	----	30	mA
Power Dissipation	P <sub>d</sub>	----	----	108	mW
Pulse Current	I <sub>peak</sub>	Duty=0.1mS, 1kHz	----	100	mA
Operating Temperature	T <sub>opr</sub>	----	-20	+85	°C
Storage Temperature	T <sub>str</sub>	----	-25	+100	°C

## **Electrical and optical characteristics (Ta = 25°C)**

Parameter	Symbol	Test Condition	Value			Unit
			Min.	Typ.	Max.	
Forward Voltage	V <sub>F</sub>	I <sub>F</sub> = 20mA	----	3.2	3.6	V
Reverse Current	I <sub>R</sub>	V <sub>R</sub> = 5V	----	----	30	μA
Luminous Intensity	I <sub>V</sub>	I <sub>F</sub> = 20mA	----	BIN	---	mcd
Viewing Angle	2θ 1/2	I <sub>F</sub> = 20mA	----	100	----	Deg.

## **Luminous Intensity Bins Chart (Ta = 25°C)**

Bin	N	P	Q	R	S	T
Min	200	300	400	600	800	1000
Max	300	400	600	800	1000	1500



# LED SPECIFICATION

Part No.: 599LW7C

## Chromaticity Coordinates Ranks (IF=20mA Ta=25°C)

Wa1	X	0.243	0.215	0.230	0.263	Wa2	X	0.263	0.246	0.264	0.280
	Y	0.200	0.230	0.250	0.220		Y	0.220	0.236	0.267	0.248
Wa3	X	0.246	0.230	0.248	0.264	Wb1	X	0.280	0.264	0.283	0.296
	Y	0.236	0.250	0.286	0.267		Y	0.248	0.267	0.305	0.276
Wb2	X	0.264	0.248	0.275	0.283	Wc1	X	0.296	0.287	0.330	0.330
	Y	0.267	0.286	0.321	0.305		Y	0.276	0.295	0.339	0.318
Wc2	X	0.287	0.283	0.330	0.330	Wc3	X	0.283	0.275	0.298	0.306
	Y	0.295	0.305	0.360	0.339		Y	0.305	0.321	0.350	0.332
Wc4	X	0.306	0.298	0.321	0.330	Wd1	X	0.330	0.330	0.361	0.356
	Y	0.332	0.350	0.379	0.360		Y	0.318	0.360	0.385	0.351
Wd2	X	0.330	0.321	0.366	0.361	Wf	X	0.356	0.366	0.391	0.380
	Y	0.360	0.379	0.419	0.385		Y	0.351	0.419	0.436	0.381

## CIE 1931 Chromaticity diagram

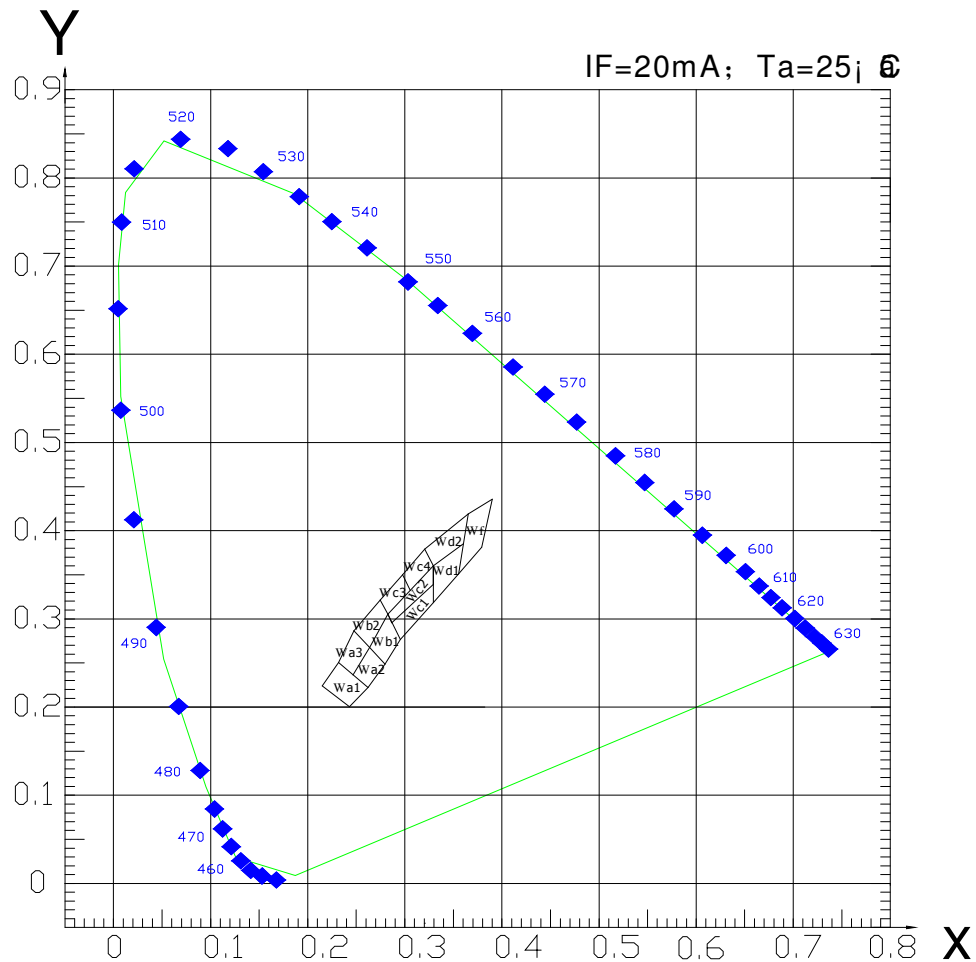



# LED SPECIFICATION

Part No.: 599LW7C

Typical electrical/optical characteristic curves:

