

CMM 220 with LF contacts

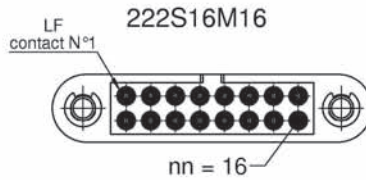
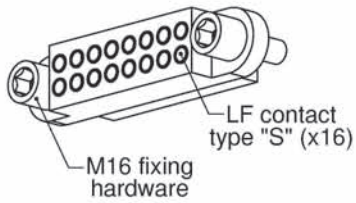
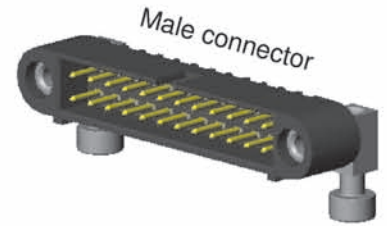
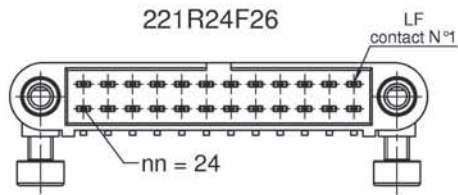
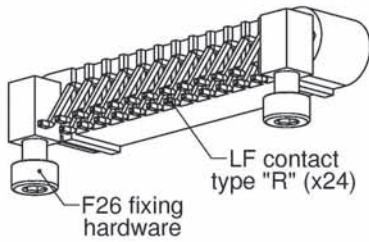

PART NUMBERING REMINDER

Code with Low Frequency contacts only					
Series	Gender	Termination Style	Number of LF contacts	Fixing Hardware	
■ ■ ■	■	■	n n	■ ■ ■	
2 rows	22	1 male	Refer to table on page 7	04 to 60	Refer to pages 43, 44, 45
		2 female			

CMM 220 Configuration

CONNECTOR SPACING

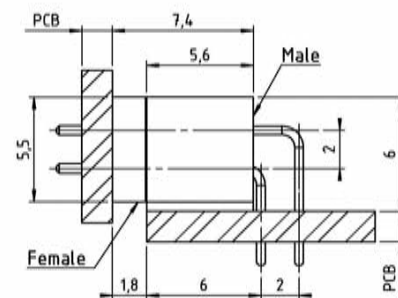
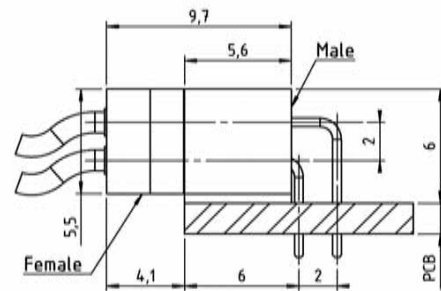
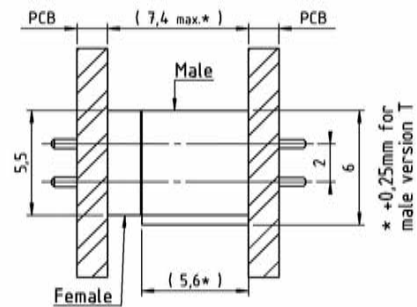
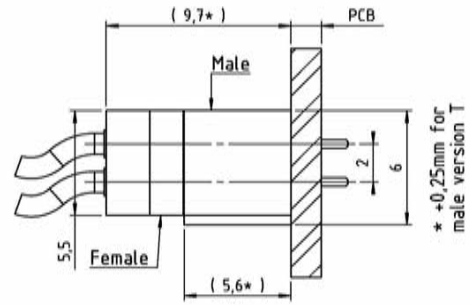
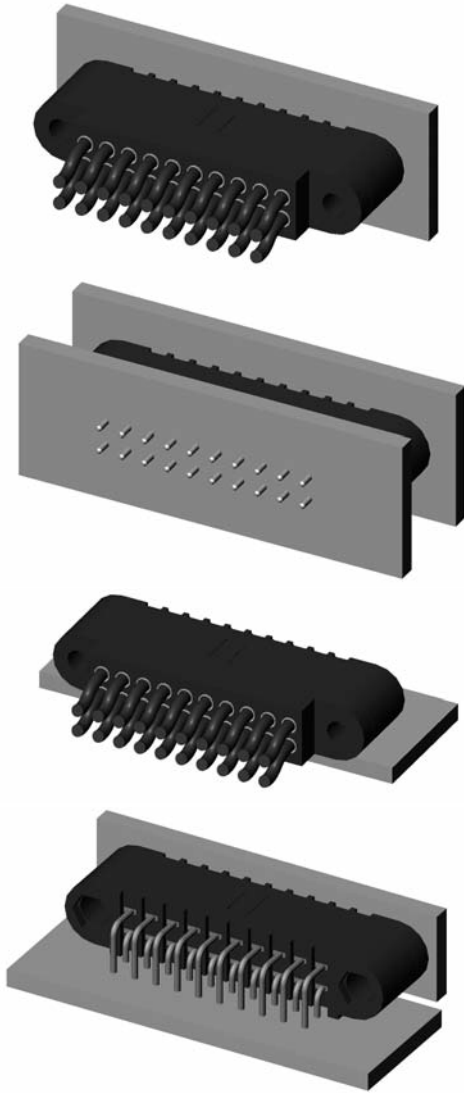

CONTACTS POSITIONS



Female connectors
(shown looking onto mating face)

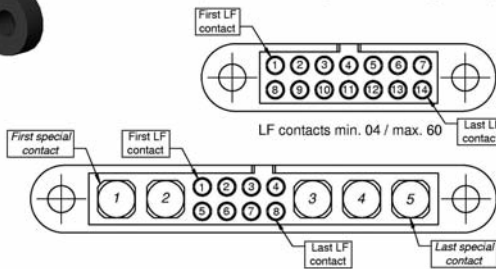

Mixed layout max. configuration depends on the total LF contacts number

Special contacts min. 02 / max. 15



Male connectors
(shown looking onto mating face)

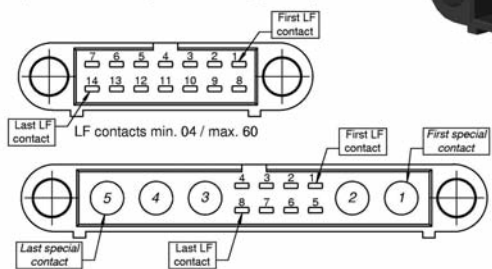

Mixed layout max. configuration depends on the total LF contacts number

Special contacts min. 02 / max. 15

CMM 220 male

STRAIGHT PCB

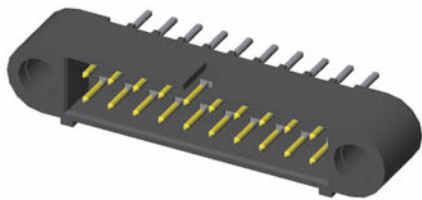

nn min = 04 nn max = 60

Part numbering :

Type :Y-YL

2 2 | n n

See Fixing on page 43, 44
"Fxx" without fixing

nn = number of LF contacts

Type	L
Y	3
YL	4,5

Calculation :

$$A = nn - 2$$

$$B = A + 7$$

$$C = A + 12$$

Refer to dimension table on cover page

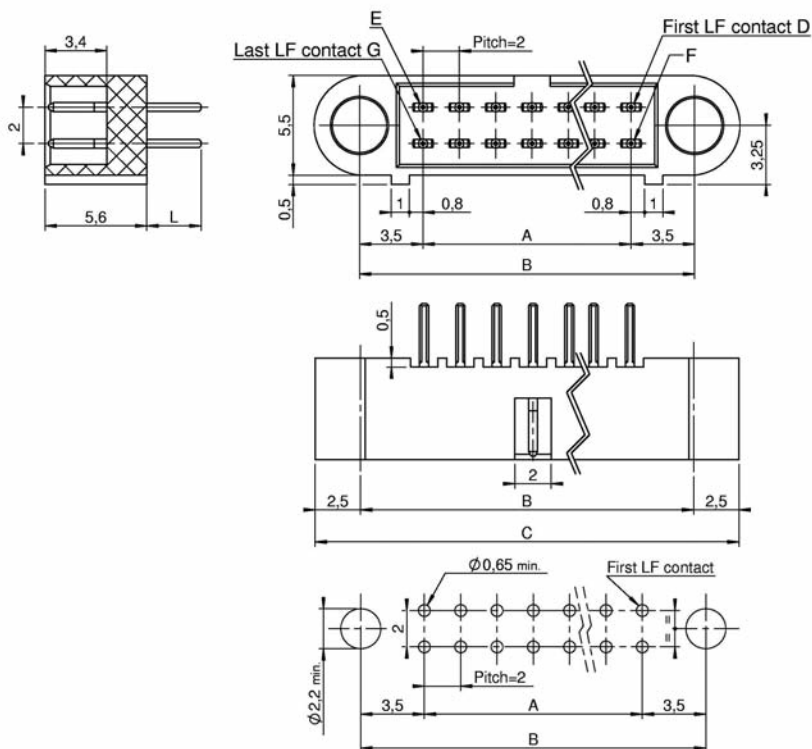

90° PCB

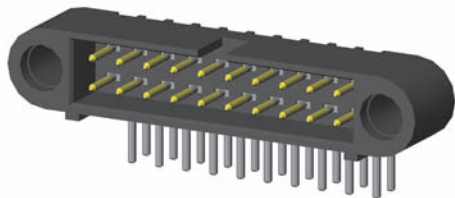

nn min = 04 nn max = 60

Part numbering :

Type :V-VL

2 2 | n n

See Fixing on page 43, 44
"Fxx" without fixing

nn = number of LF contacts

Type	L
V	3
VL	4,5

Calculation :

$$A = nn - 2$$

$$B = A + 7$$

$$C = A + 12$$

Refer to dimension table on cover page

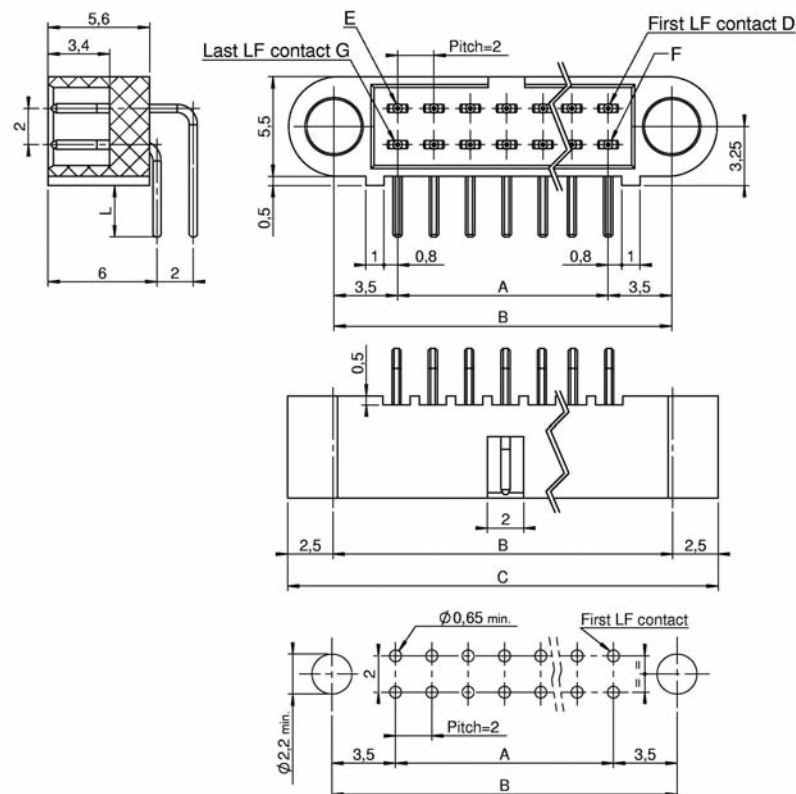

CMM 220 male

STRAIGHT SMT

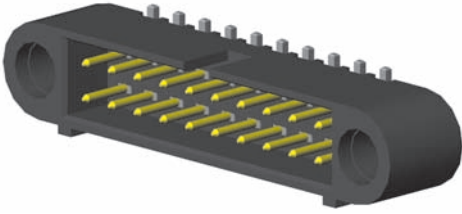

nn min = 04 nn max = 60

Part numbering :

Type : T-TL

2 2 1 n n

See Fixing on page 43, 44
"Fxx" without fixing

nn = number of LF contacts

Calculation :

A	= nn - 2
----------	----------

B	= A + 7
----------	---------

C	= A + 12
----------	----------

Refer to dimension table on cover page

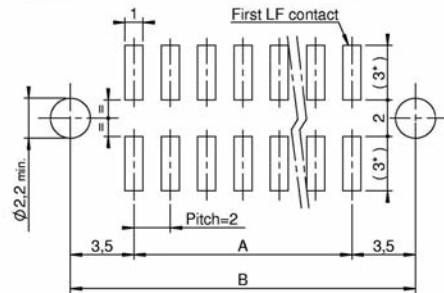
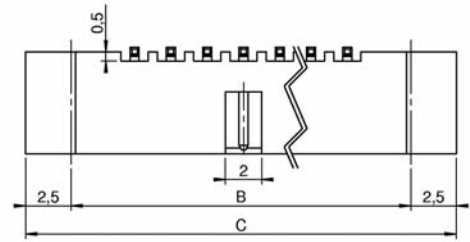
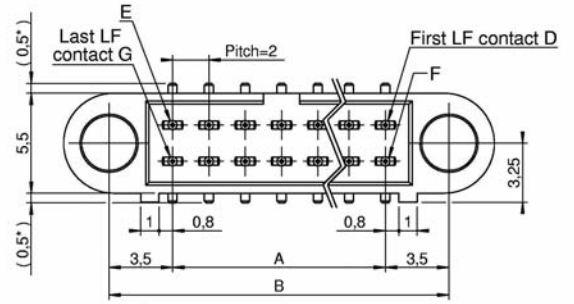
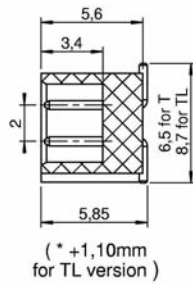

90° SMT

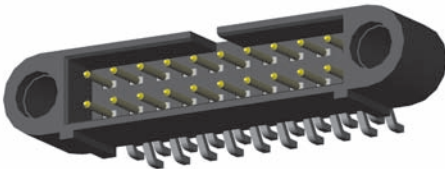

nn min = 04 nn max = 60

Part numbering :

2 2 1 R n n

See Fixing on page 43, 44
"Fxx" without fixing

nn = number of LF contacts

Calculation :

A	= nn - 2
----------	----------

B	= A + 7
----------	---------

C	= A + 12
----------	----------

Refer to dimension table on cover page

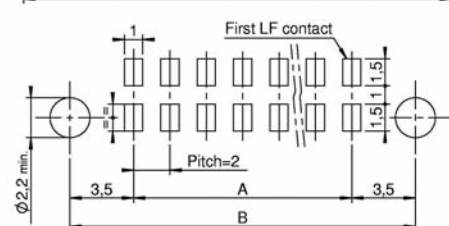
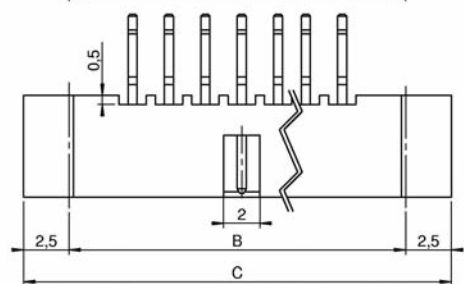
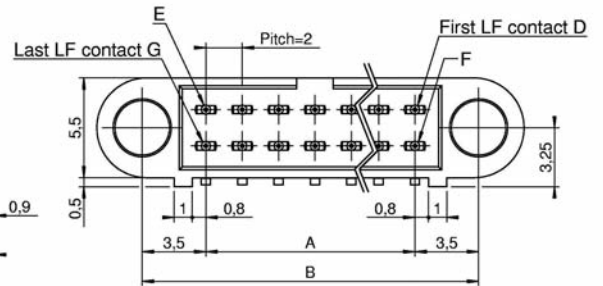
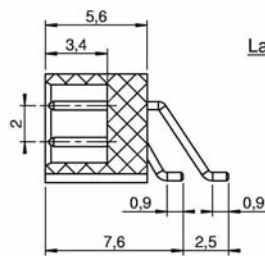

CMM 220 male

CRIMP

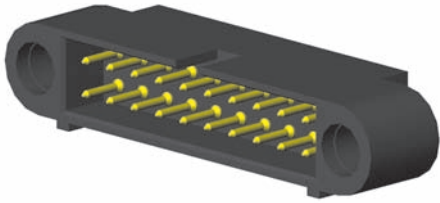

nn min = 04 nn max = 60

Part numbering :

Type : S-C

2 2 | n n

See Fixing on page 43, 44
"Fxx" without fixing

nn = number of LF contacts

Type	Gauge
S	24-28
C	22

Calculation :

$$A = nn - 2$$

$$B = A + 7$$

$$C = A + 12$$

Refer to dimension table on cover page

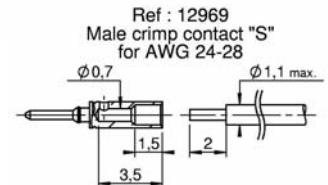
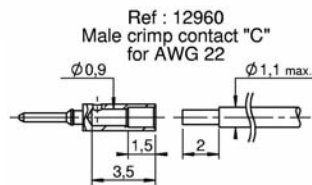
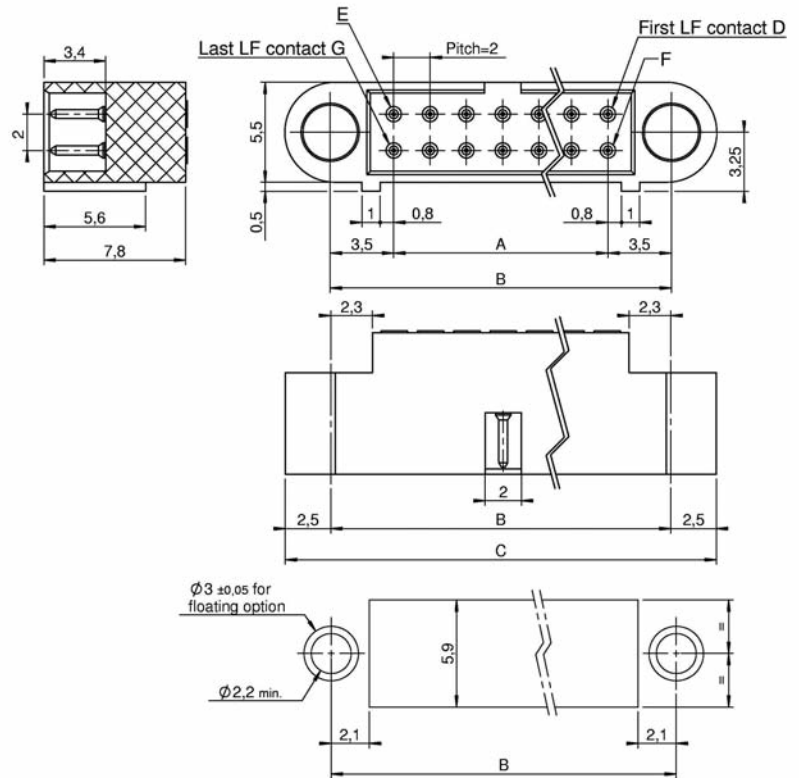

CMM 220 female

STRAIGHT PCB

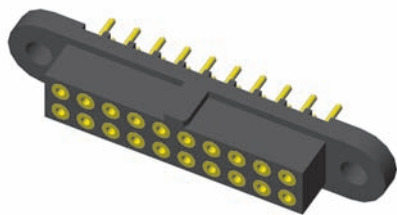

nn min = 04 nn max = 60

Part numbering :

Type :Y-YL

2 2 2 n n

See Fixing on page 45-46
"Mxx" without fixing

nn = number of LF contacts

Type	L
Y	3
YL	4,5

Calculation :

$$A = nn - 2$$

$$B = A + 7$$

$$C = A + 12$$

Refer to dimension table on cover page

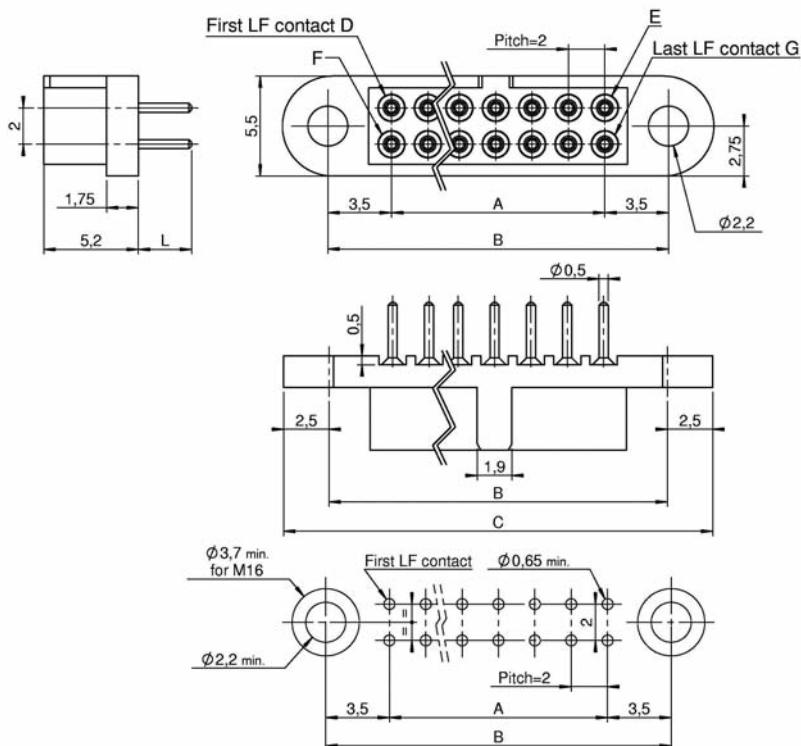

90° PCB

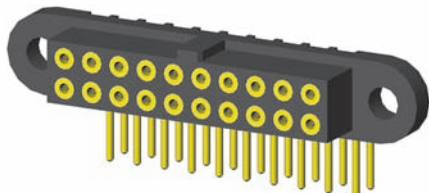

nn min = 04 nn max = 60

Part numbering :

Type :V-VL

2 2 2 n n

See Fixing on page 45
"Mxx" without fixing

nn = number of LF contacts

Type	L
V	3
VL	4,5

Calculation :

$$A = nn - 2$$

$$B = A + 7$$

$$C = A + 12$$

Refer to dimension table on cover page

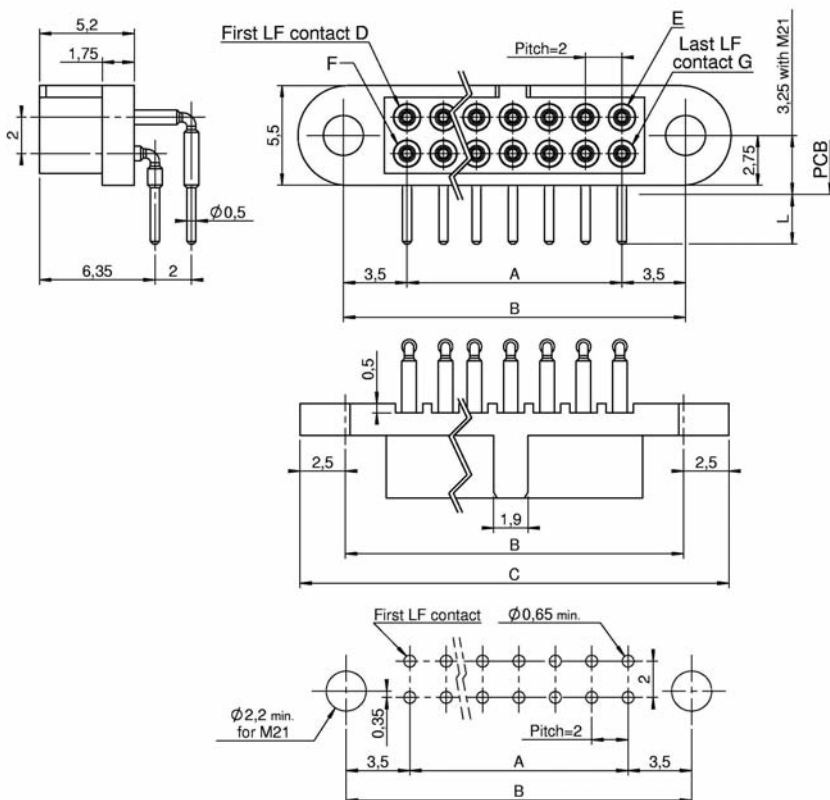

CMM 220 female

STRAIGHT SMT

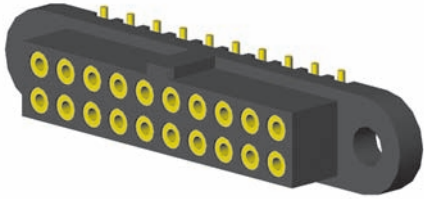

nn min = 04 nn max = 60

Part numbering :

Type : T-TL

2 2 2 n n

See Fixing on page 45-46
"Mxx" without fixing

nn = number of LF contacts

Calculation :

$$A = nn - 2$$

$$B = A + 7$$

$$C = A + 12$$

Refer to dimension table on cover page

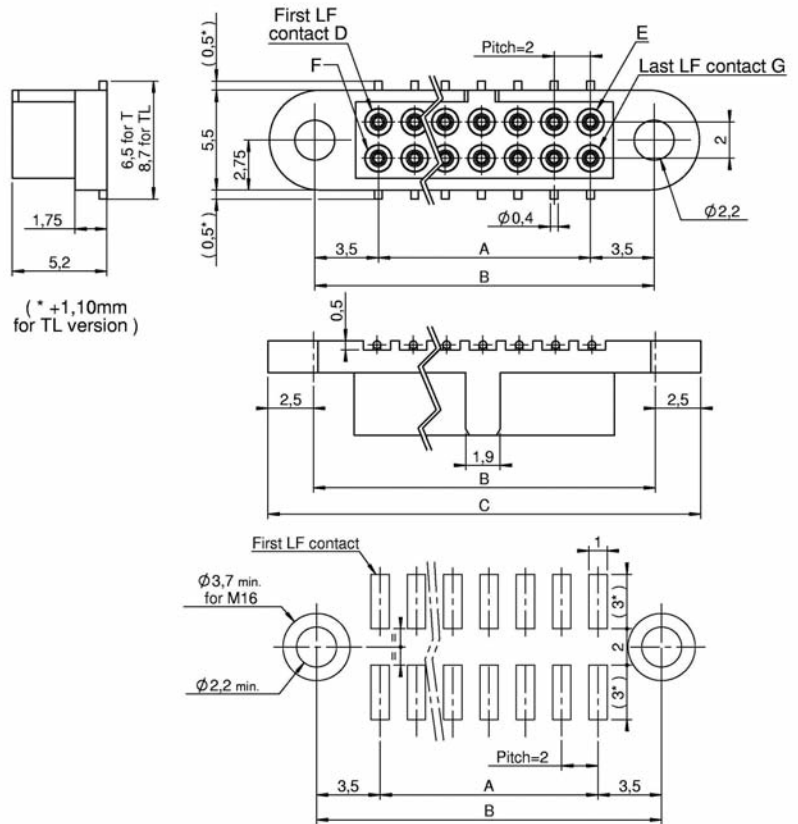

90° SMT

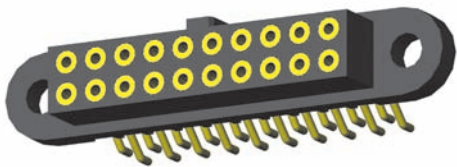

nn min = 04 nn max = 60

Part numbering :

2 2 2 R n n

See Fixing on page 45
"Mxx" without fixing

nn = number of LF contacts

Calculation :

$$A = nn - 2$$

$$B = A + 7$$

$$C = A + 12$$

Refer to dimension table on cover page

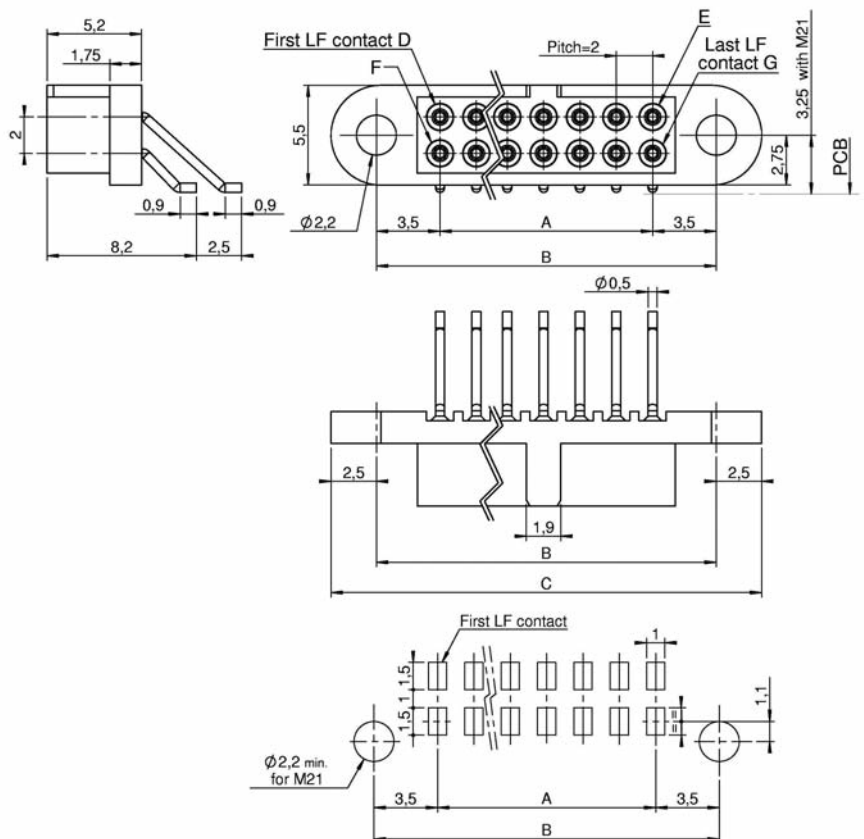

CMM 220 female

STRAIGHT PRESS FIT

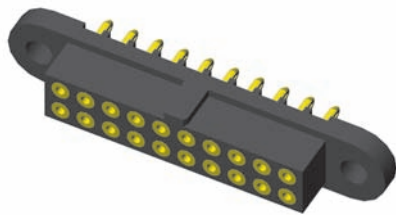

nn min = 04 nn max = 60

Part numbering :

2 2 2 PF n n

See Fixing on page 45-46
"Mxx" without fixing

nn = number of LF contacts

Calculation :

$$A = nn - 2$$

$$B = A + 7$$

$$C = A + 12$$

Refer to dimension table on cover page

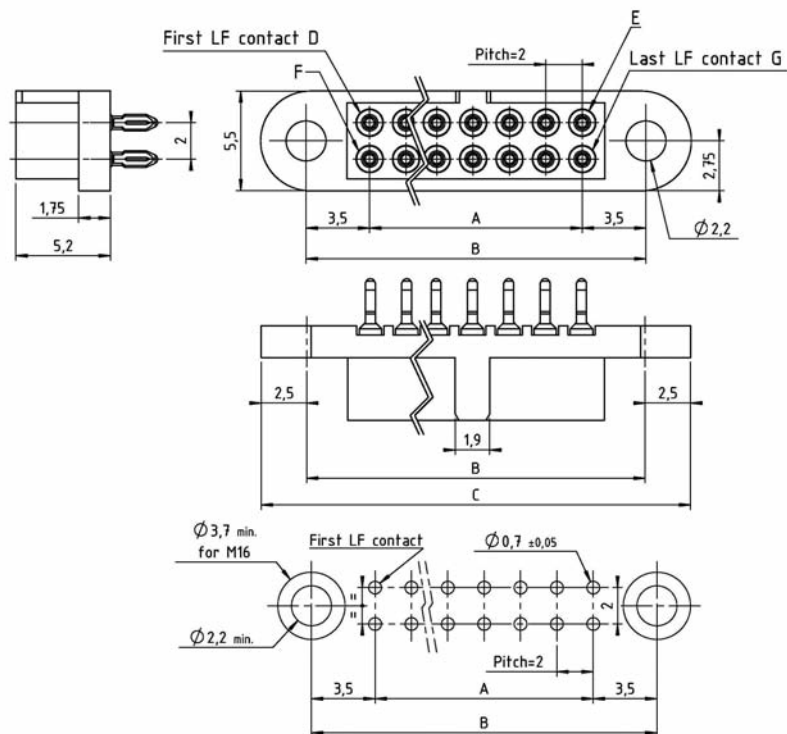

CRIMP



nn min = 04 nn max = 60

Part numbering :

Type : S-C

2 2 2 n n

See Fixing on page 45-46
"Mxx" without fixing

nn = number of LF contacts

Type	Gauge
S	24-28
C	22

Calculation :

$$A = nn - 2$$

$$B = A + 7$$

$$C = A + 12$$

Refer to dimension table on cover page

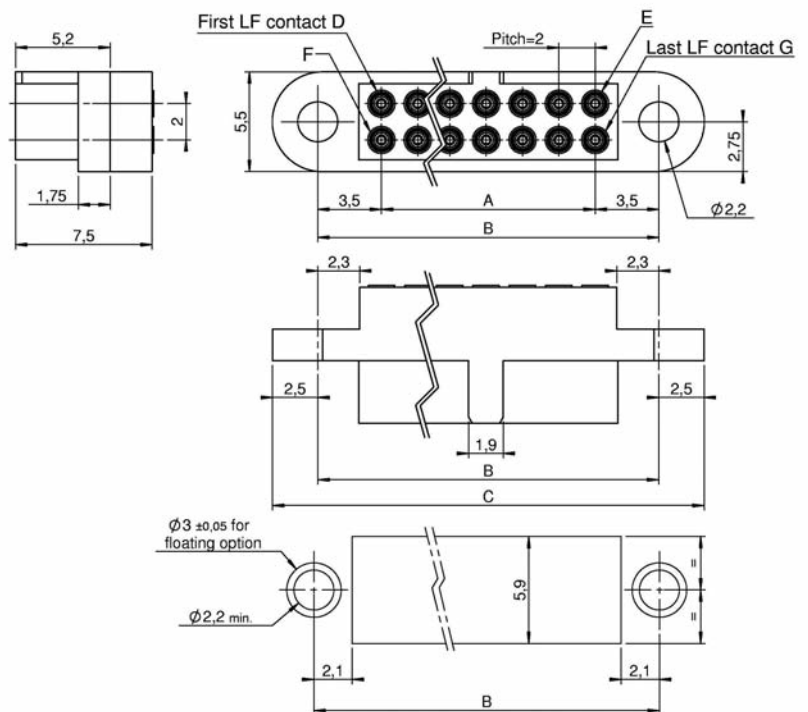

Ref : C13064-P
Female crimp contact "C"
for AWG 22 cable

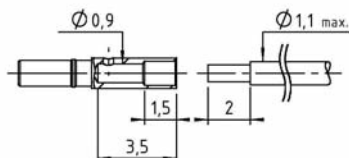

Ref : C12468
Female crimp contact "S"
for AWG 24-28

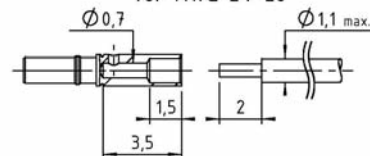

CMM 220 mixed-layout

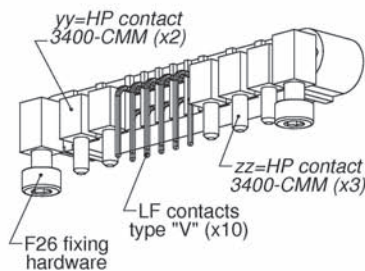

221V10F26-0203-3400CMM

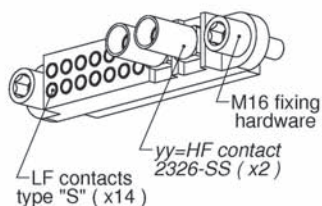
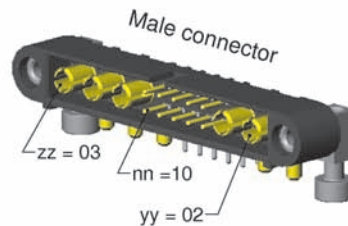
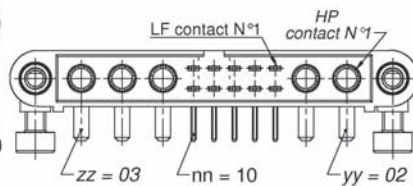

222S14M16-0200-2326SS

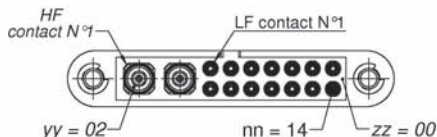

(HF contacts are supplied -not fitted- under P/N 30-2326-SS)

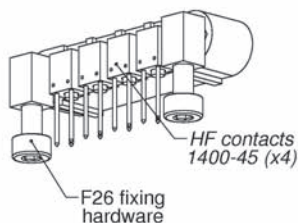
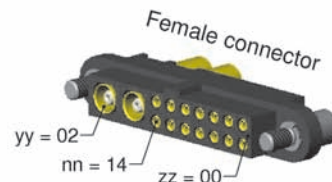

221D00F26-0004-140045

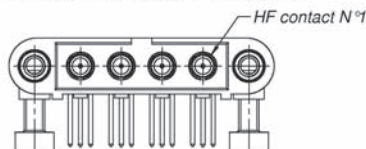

"D" stated in P/N for connectors on PCB with only special contacts.

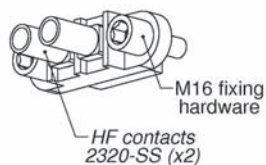
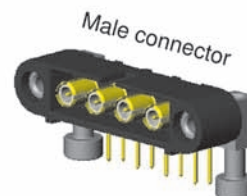

222E00M16-0002-2320SS

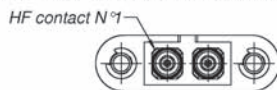

(HF contacts are supplied -not fitted- under P/N 30-2320-SS)

"E" stated in P/N for connectors on cable with only special contacts.

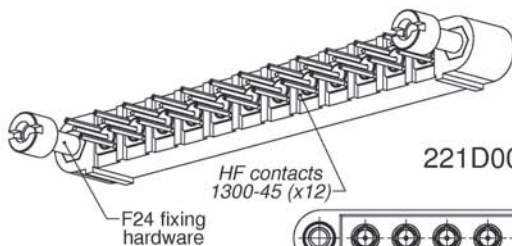

221D00F24-0012-130045

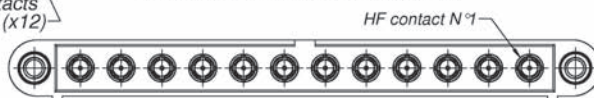

"D" stated in P/N for connectors on PCB with only special contacts.

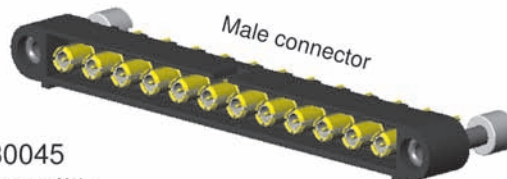

PART NUMBERING REMINDER

Code with Low Frequency contacts only					Additional code for mixed-layout connector (HF/HP)		
Series	Gender	Termination Style	Number of LF contacts	Fixing Hardware	Number of HF/HP contacts pin 1 side (LF contact number 1)	Number of HF/HP contacts opposite to LF contact number 1	HF/HP Contact Type
22	1 male 2 female	Refer to table on page 7	04 to 60	Refer to pages 43, 44, 45	Depends upon the number of LF contacts If use with shifted central key, please refer to page 42 HF / HP : 15 contacts max. Type of HF/HP contact : please refer to pages 8-9	HP/HP 30 please refer to pages 75 to 92	

CMM 220

Male mixed-layout

STRAIGHT PCB



Part numbering :

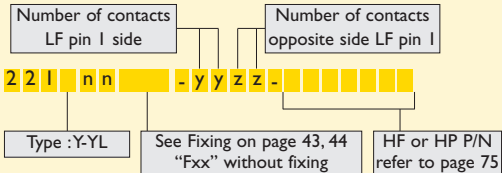

nn = number of LF contacts

Type	L
Y	3
YL	4,5

Pattern for special contact :

HF 30-1300-xx PCB lay-out

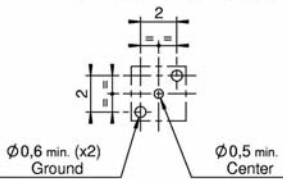

HP 30-3300-xx PCB lay-out

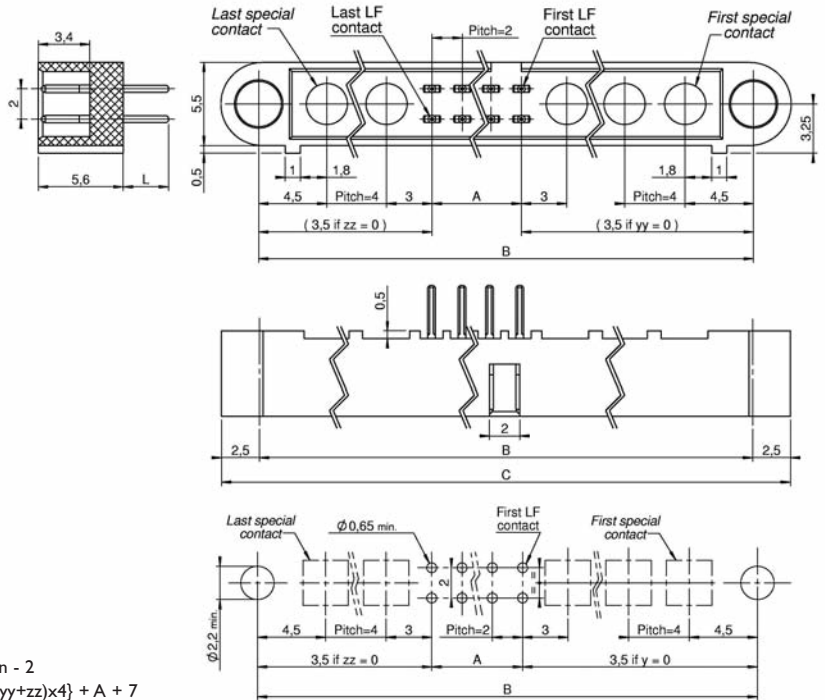
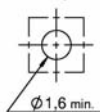

$$A = nn - 2$$

$$B = \{(yy+zz) \times 4\} + A + 7$$

$$B_{max.} = 65 \text{ mm}$$

$$C = B + 5$$

STRAIGHT PCB FOR HP/HF CONTACTS ONLY

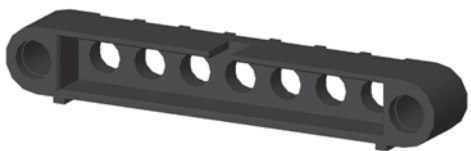

Part numbering :

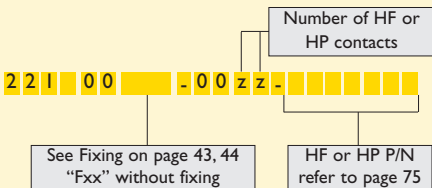

Pattern for special contact :

HF 30-1300-xx PCB lay-out

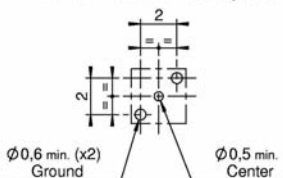

HP 30-3300-xx PCB lay-out

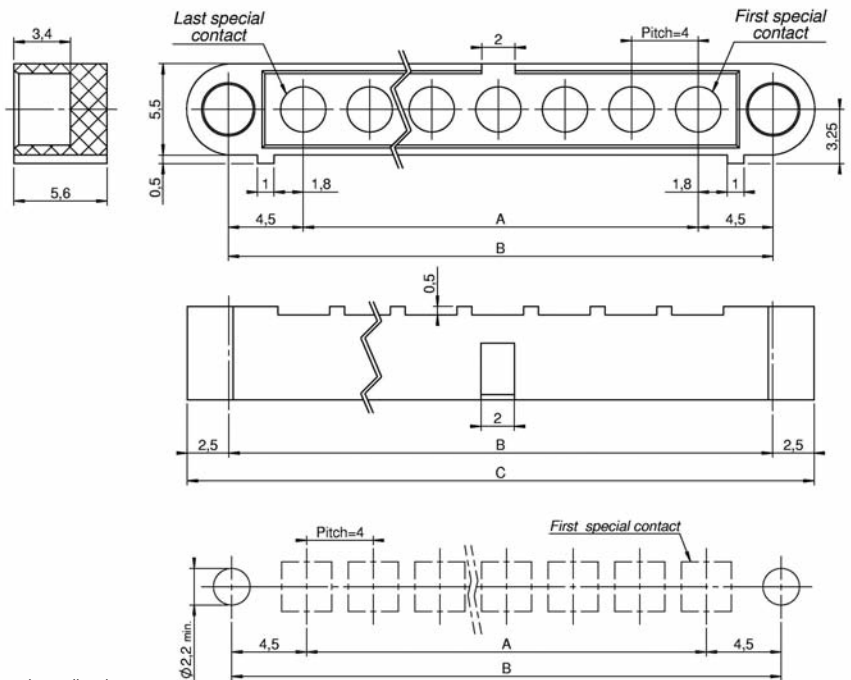
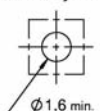

$$A = (zz \times 4) - 4$$

$$B = A + 9$$

$$C = B + 5$$

Special contacts min. : 02
max. : 15

Refer to dimension table on cover page

CMM 220

Male mixed-layout

90° PCB

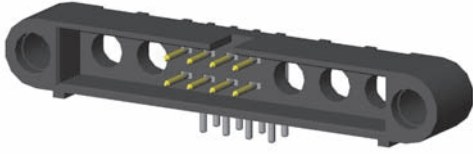

Part numbering :

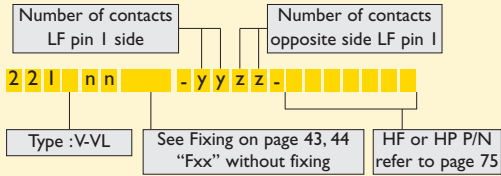

nn = number of LF contacts

Type	L
V	3
VL	4,5

Pattern for special contact :

HF 30-1400-xx PCB lay-out

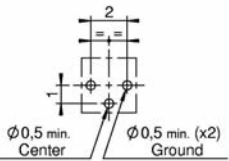

HP 30-3400-xx PCB lay-out

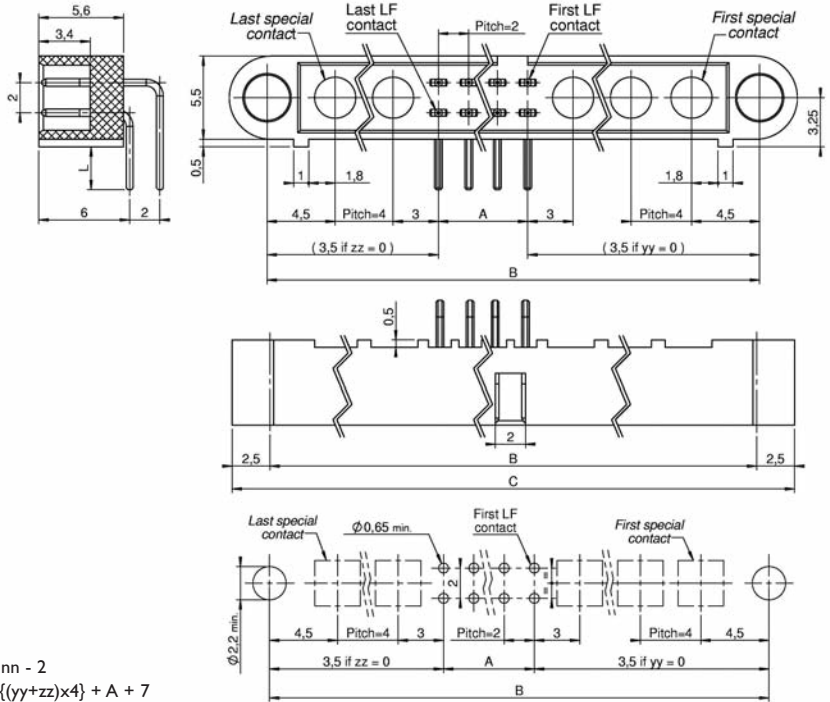
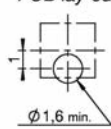

$$A = nn - 2$$

$$B = \{(yy+zz) \times 4\} + A + 7$$

$$B_{max.} = 65 \text{ mm}$$

$$C = B + 5$$

90° PCB FOR HP/HF CONTACTS ONLY

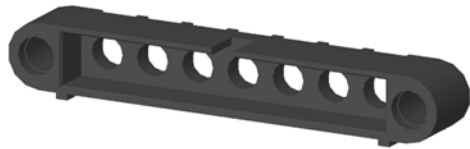

Part numbering :

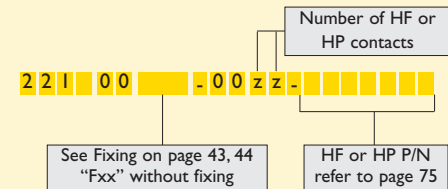

Pattern for special contact :

HF 30-1400-xx PCB lay-out

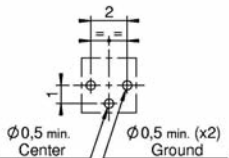

HP 30-3400-xx PCB lay-out

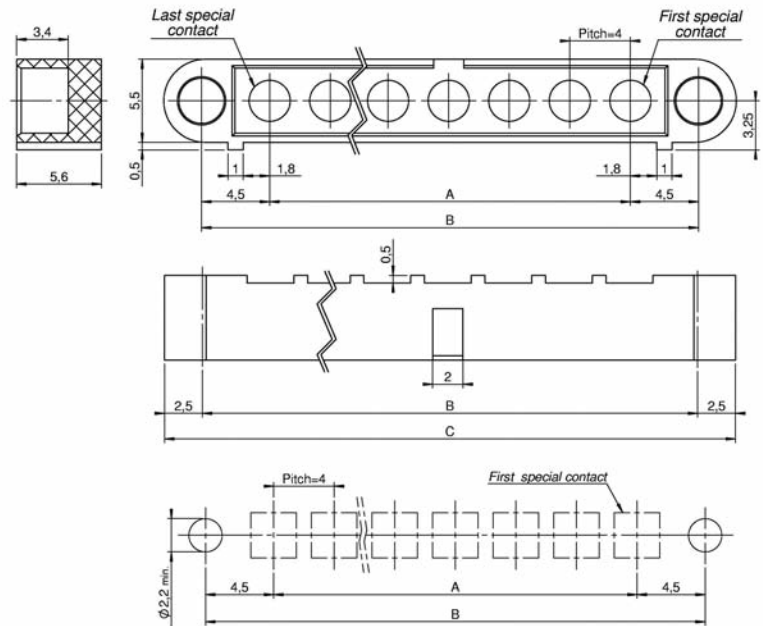
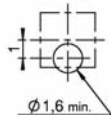

$$A = (zz \times 4) - 4$$

$$B = A + 9$$

$$C = B + 5$$

Special contacts min. : 02
max. : 15

Refer to sizes information table on cover page

CMM 220

Male mixed-layout

CRIMP

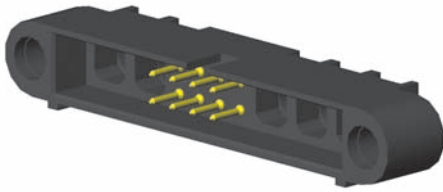

Part numbering :

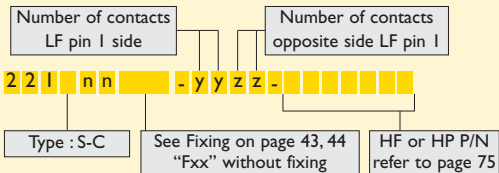

nn = number of LF contacts

Type	Gauge
S	24-28
C	22

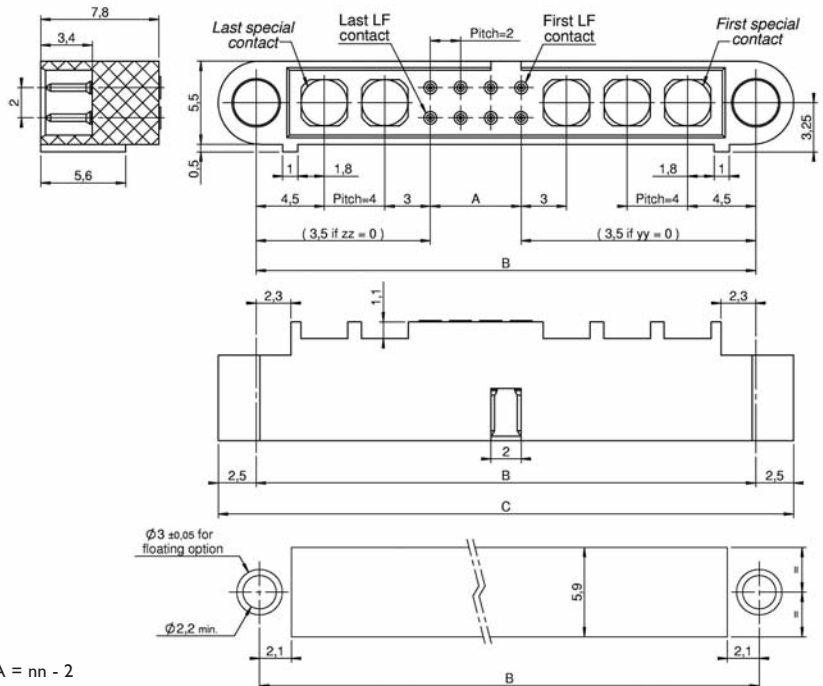
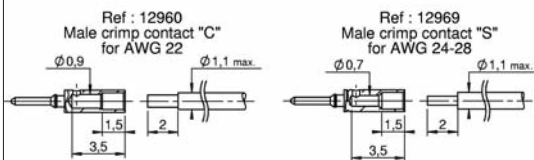

$$A = nn - 2$$

$$B = \{(yy+zz) \times 4\} + A + 7$$

$$B_{max} = 65 \text{ mm}$$

$$C = B + 5$$

CRIMP FOR HP/HF CONTACTS ONLY

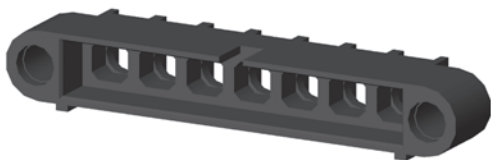

Part numbering :

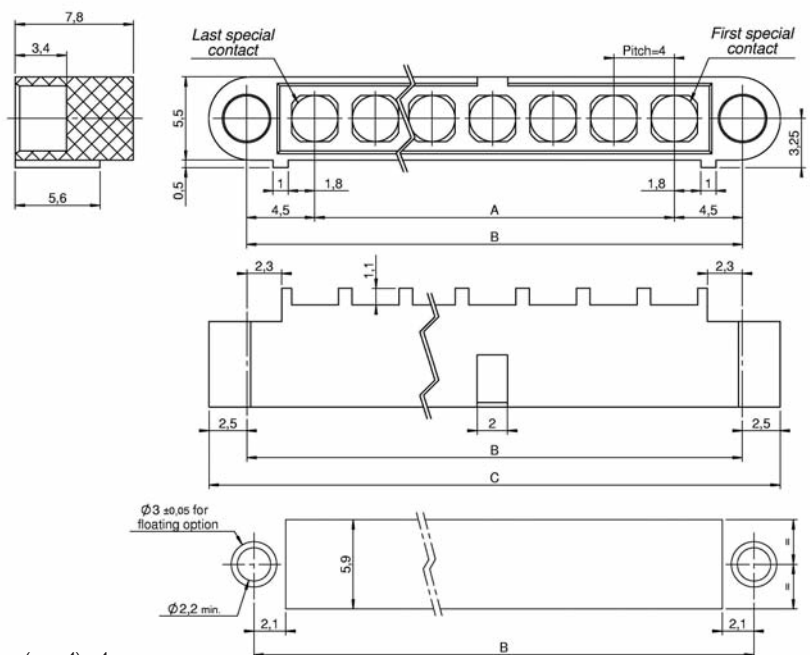
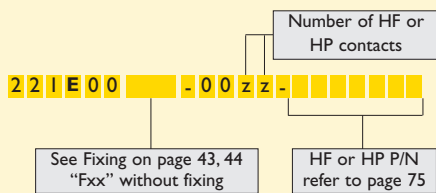

$$A = (zz \times 4) - 4$$

$$B = A + 9$$

$$C = B + 5$$

Special contacts min. : 02
max. : 15

Refer to dimension table on cover page

CMM 220

Female mixed-layout

STRAIGHT PCB



Part numbering :

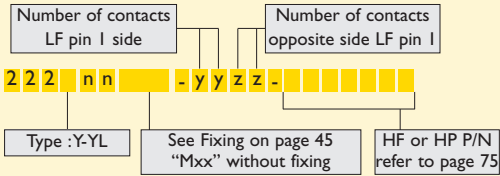

nn = number of LF contacts

Type	L
Y	3
YL	4,5

Pattern for special contact :

HF 30-2300-xx PCB lay-out

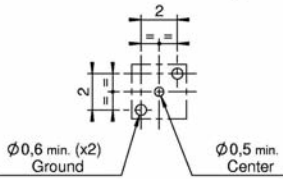

HP 30-4300-xx PCB lay-out

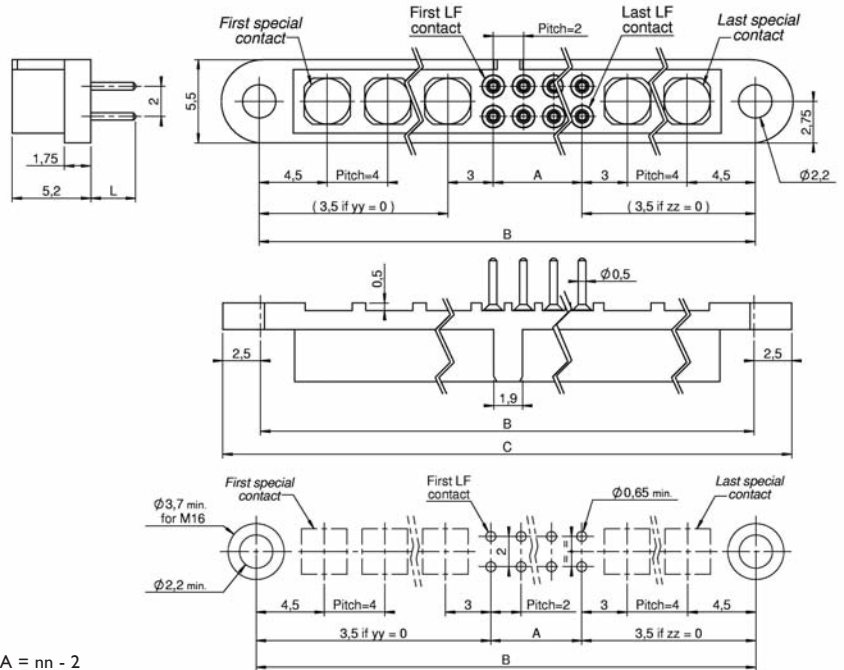
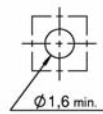

$$A = nn - 2$$

$$B = ((yy+zz) \times 4) + A + 7$$

$$B_{max.} = 65 \text{ mm}$$

$$C = B + 5$$

STRAIGHT PCB FOR HP/HF CONTACTS ONLY

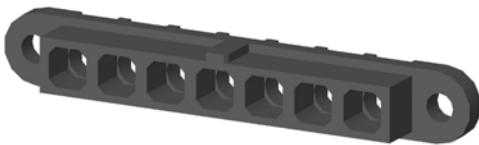

Part numbering :

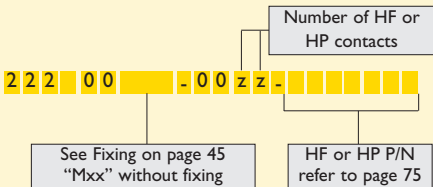

Pattern for special contact :

HF 30-2300-xx PCB lay-out

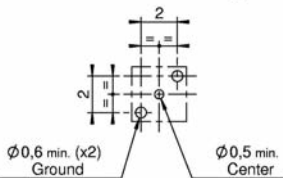

HP 30-4300-xx PCB lay-out

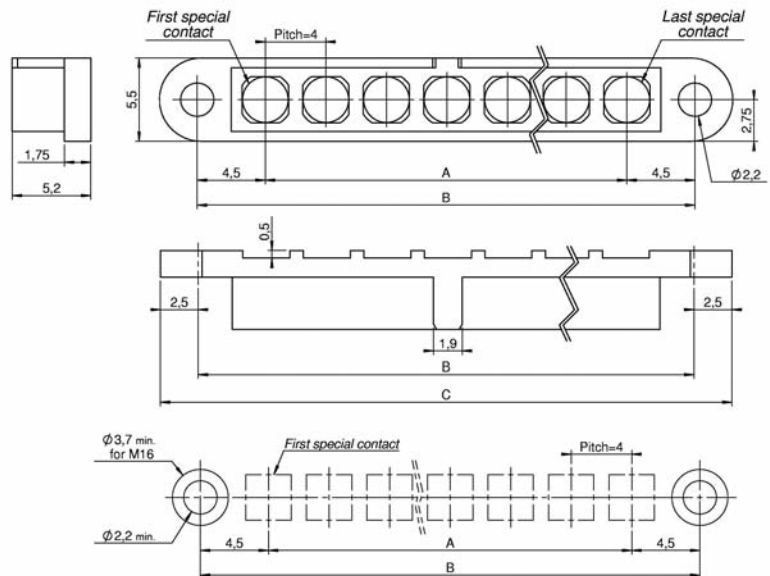
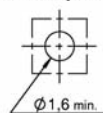

Special contacts min.: 02
max.: 15

$$A = (zz \times 4) - 4$$

$$B = A + 9$$

$$C = B + 5$$

Refer to dimension table on cover page

CMM 220

Female mixed-layout

90° PCB

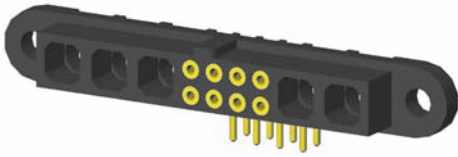

Part numbering :

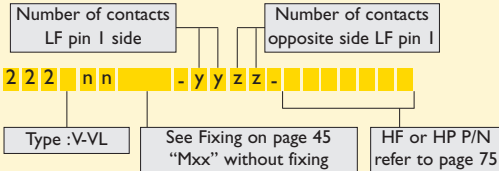

nn = number of LF contacts

Type	L
V	3
VL	4,5

Pattern for special contact :

HF 30-2400-xx PCB lay-out

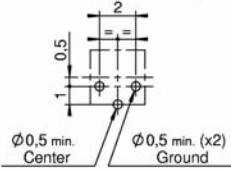

HP 30-4400-xx PCB lay-out

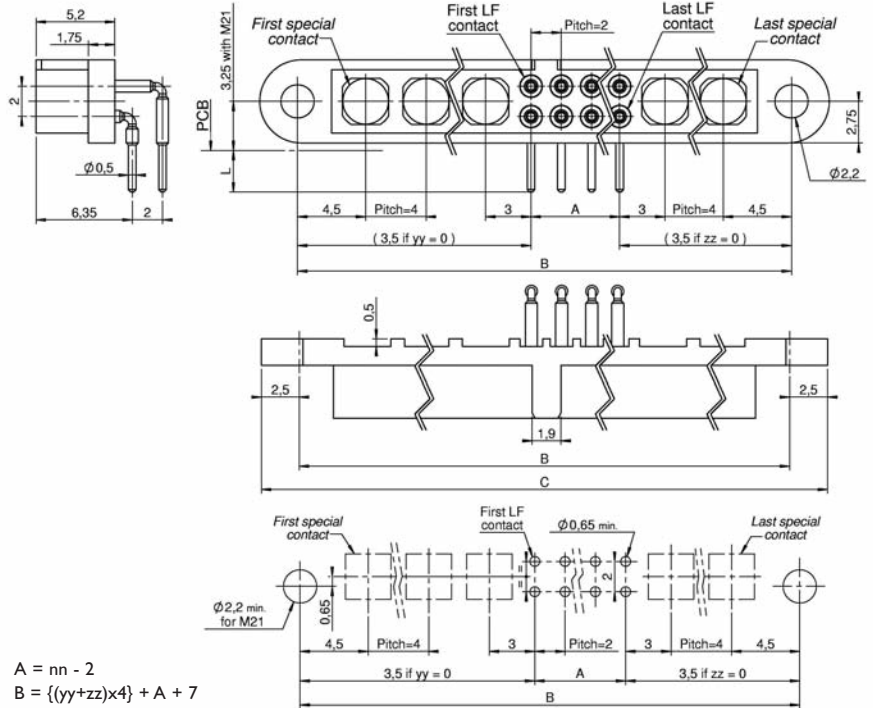
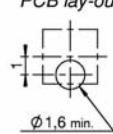

$$A = nn - 2$$

$$B = \{(yy+zz) \times 4\} + A + 7$$

$$B_{max} = 65 \text{ mm}$$

$$C = B + 5$$

90° PCB FOR HP/HF CONTACTS ONLY

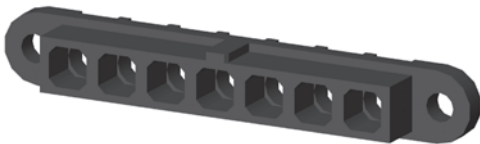

Part numbering :

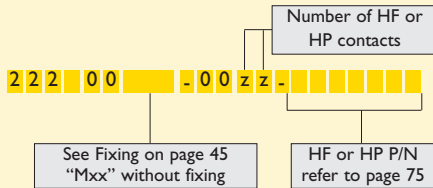

Pattern for special contact :

HF 30-2400-xx PCB lay-out

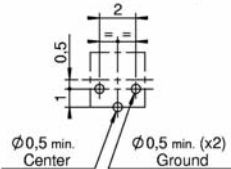

HP 30-4400-xx PCB lay-out

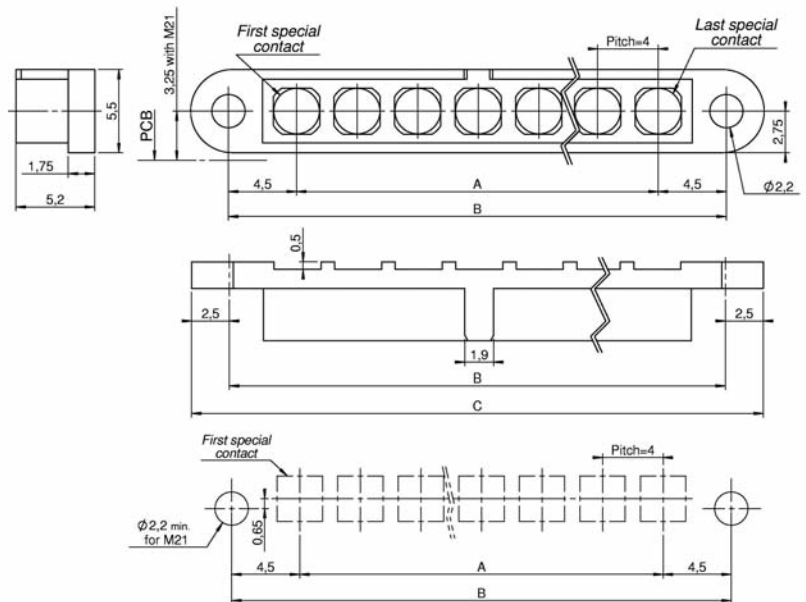
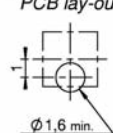

$$A = (zz \times 4) - 4$$

$$B = A + 9$$

$$C = B + 5$$

Special contacts min. : 02
max. : 15

Refer to dimension table on cover page

CMM 220

Female mixed-layout

CRIMP

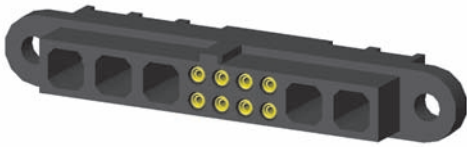

Part numbering :

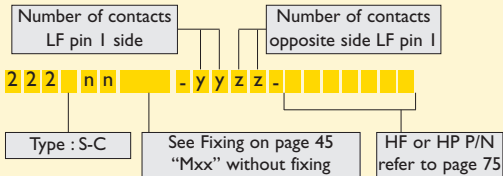

nn = number of LF contacts

Type	Gauge
S	24-28
C	22

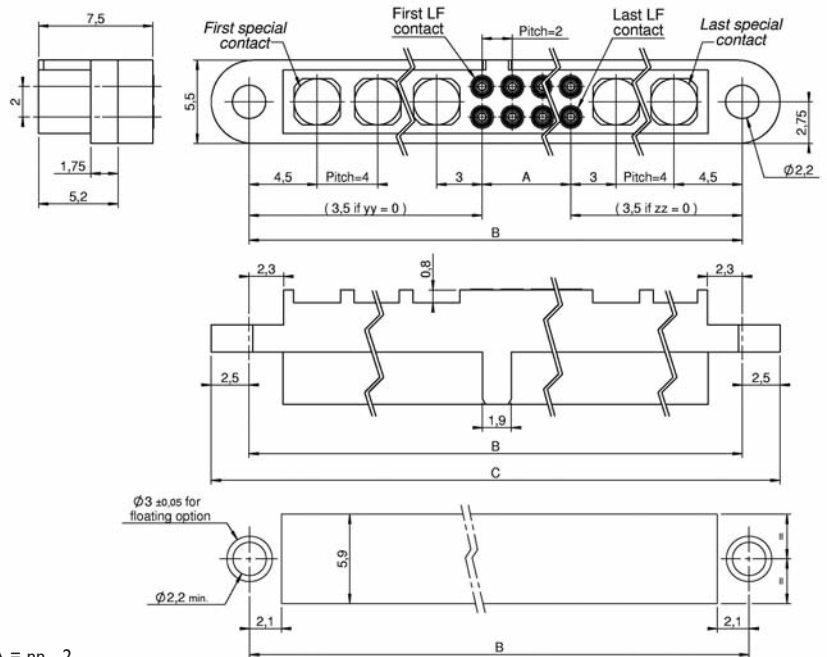
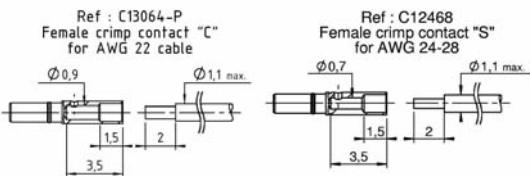

$$A = nn - 2$$

$$B = ((yy+zz) \times 4) + A + 7$$

$$B_{max} = 65 \text{ mm}$$

$$C = B + 5$$

CRIMP FOR HP/HF CONTACTS ONLY

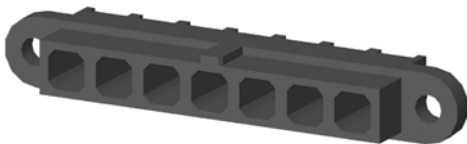

Part numbering :

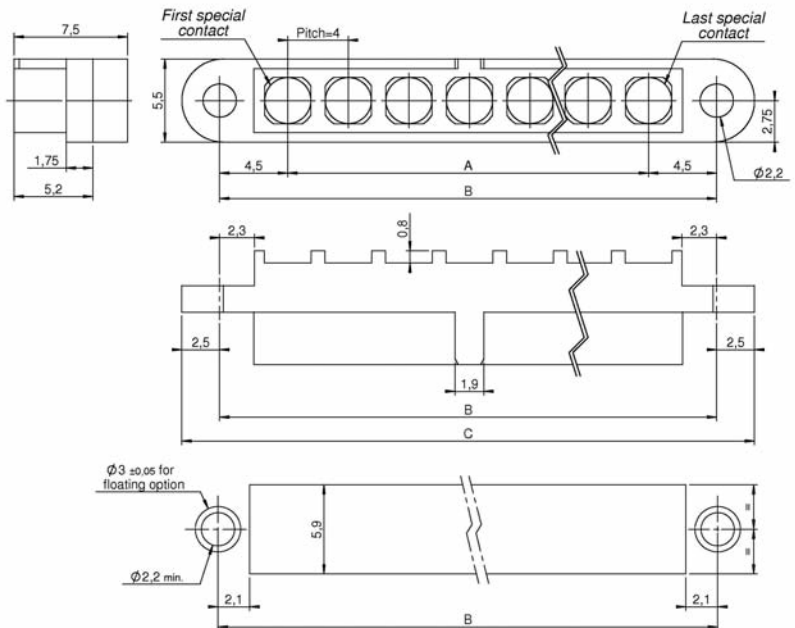
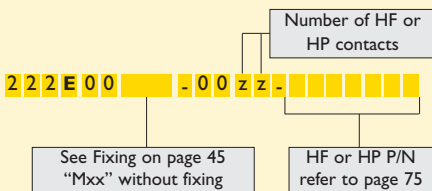

$$A = (zz \times 4) - 4$$

$$B = A + 9$$

$$C = B + 5$$

Special contacts min. : 02
max. : 15

Refer to dimension table
on cover page

Part numbering with shifted polarization key position

PART NUMBERING

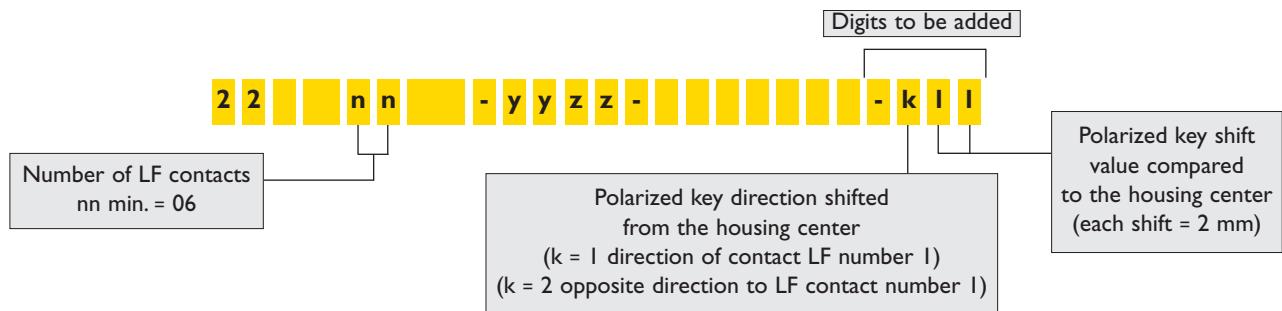

EXPLANATION

Shown looking onto mating face (Example with Male housing)

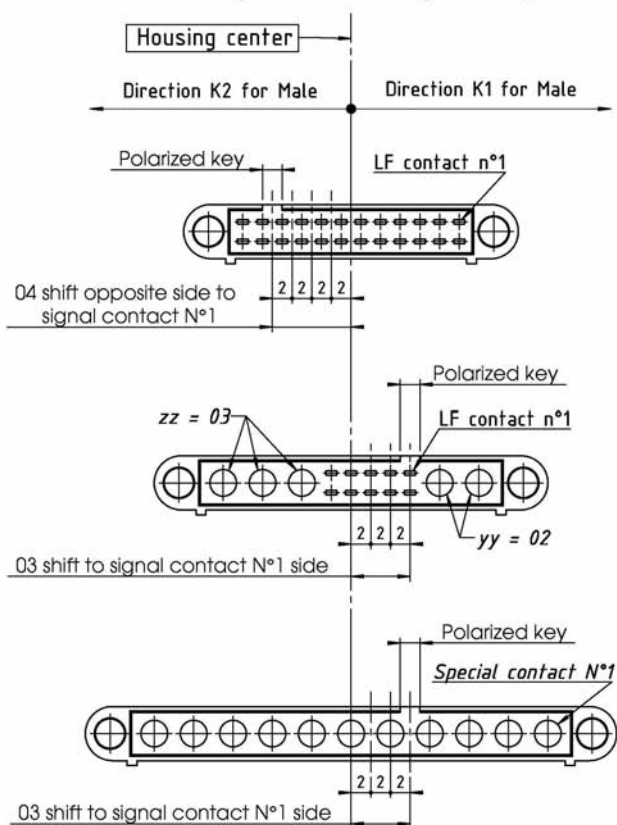

CMM220 with LF contacts only with shifted polarized key.

Example : 2 2 | 1 | 2 4 Fxx - 2 0 4

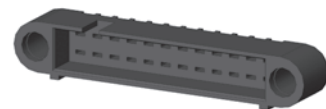

CMM220 with LF contacts and Special contacts with shifted polarized key.

Example : 2 2 | 1 | 1 0 Fxx - 0 2 0 3 - - - - - - - - - - - 1 0 3



CMM220 with Special contacts only with shifted polarized key.

Example : 2 2 | 1 | 0 0 Fxx - 0 0 1 1 - - - - - - - - - - - 1 0 3



EXAMPLES

Connectors Male & Female CMM series 220 LF and special contacts mixed

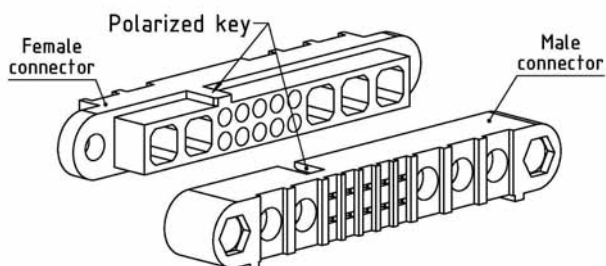

Male : 2 2 | 1 | 1 0 Fxx - 0 2 0 3 - - - - - - - - - - - 1 0 3
Female : 2 2 | 2 | 1 0 Mxx - 0 2 0 3 - - - - - - - - - - - 1 0 3

Connectors Male & Female CMM series 220 special contacts only

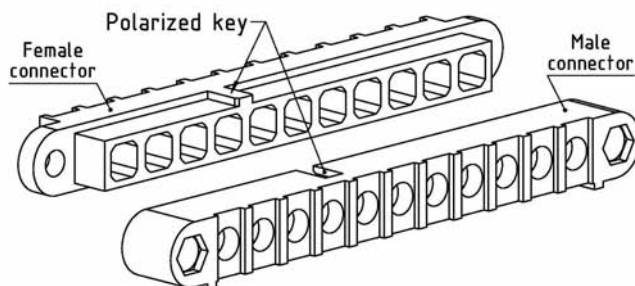

Male : 2 2 | 1 | 0 0 Fxx - 0 0 1 1 - - - - - - - - - - - 1 0 3
Female : 2 2 | 2 | 0 0 Mxx - 0 0 1 1 - - - - - - - - - - - 1 0 3

Fixing hardware interconnection table for CMM 220

MALE CONNECTORS CMM SERIES 220

Type of contact in connector		PCB Contacts																			Contacts on cable							
		Type of PCB mount		Straight			90°			Card edge only HF			Card edge HF & LF			No fixing on PCB			Straight		90°			Floating	No fixing on PCB		With cover	
		PCB thickness (mm)	0,8 min. 2 max.	1,5 min. 4 max.	4 max.	2,5 max.	4,5 max.	F27	F34	F21	F60	F61	F22	F24	F25	F26 F23	F30	F30H	F31	F31H	F2xx	F21	F60	F61	F28			
PCB Contacts	Smooth	Straight	0,8 min. 2 max. M12	OK	OK	OK	OK	OK	OK	OK	OK	OK	OK	OK	OK	OK	OK	OK	OK	OK	OK	OK	OK	OK	OK	OK		
			M12H	OK	OK	OK	OK	OK	OK	OK	OK	OK	OK	OK	OK	OK	OK	OK	OK	OK	OK	OK	OK	OK	OK	OK	OK	
			1,5 min. 4 max. M12L	OK	OK	OK	OK	OK	OK	OK	OK	OK	OK	OK	OK	OK	OK	OK	OK	OK	OK	OK	OK	OK	OK	OK	OK	
			M12LH	OK	OK	OK	OK	OK	OK	OK	OK	OK	OK	OK	OK	OK	OK	OK	OK	OK	OK	OK	OK	OK	OK	OK	OK	
	Locked	Straight	1,5 min. 2,5 max. M46																									
			M46H																									
			1,5 min. 4 max. M47																									
			M47H																									
		90°	1,6 M21	OK	OK	OK	OK	A	A	A	A	A		OK	OK		A	A	A	A	A	OK	OK			B		
			3,2 M21L	OK	OK	OK	OK	A	A	A	A	A		OK	OK		A	A	A	A	A	OK	OK			B		
			1,6 M48											OK													OK	
			2 M48M											OK													OK	
Without	3,2 M48L											OK													OK			
	M16	OK	OK	OK	OK	OK	OK	OK	OK	OK	OK	OK	OK		OK	OK		OK	OK	OK	OK			OK				
	M11	OK	OK	OK	OK	OK	OK	OK	OK	OK	OK	OK	OK		OK	OK		OK	OK	OK	OK			OK				
	M11	OK	OK	OK	OK	OK	OK	OK	OK	OK	OK	OK	OK		OK	OK		OK	OK	OK	OK			OK				
Contacts on cable	Smooth	Straight	0,8 min. 2 max. M12	OK	OK	OK	OK	OK	OK	OK	OK	OK	OK	OK	OK	OK	OK	OK	OK	OK	OK	OK	OK	OK	OK			
			M12L	OK	OK	OK	OK	OK	OK	OK	OK	OK	OK	OK	OK	OK	OK	OK	OK	OK	OK	OK	OK	OK	OK	OK		
			M1xx	OK	OK	OK	OK	OK	OK	OK	OK	OK	OK	OK	OK		OK	OK		OK	OK	OK	OK			OK		
	Locked	Straight	1,5 min. 2,5 max. M46																									
			M47																									
			1,6 M21	OK	OK	OK	OK	A	A	A	A	A		OK	OK		A	A	A	A	A	OK	OK			B		
		90°	3,2 M21L	OK	OK	OK	OK	A	A	A	A	A		OK	OK		A	A	A	A	A	OK	OK			B		
			1,6 M48											OK													OK	
			2 M48M											OK													OK	
			3,2 M48L											OK													OK	
		Without	M16	OK	OK	OK	OK	OK	OK	OK	OK	OK	OK	OK	OK		OK	OK		OK	OK	OK	OK			OK		
			M18	OK	OK	OK	OK	B	B	B	B	B	OK	OK	OK		OK	OK		B	B	B	B	B	OK	OK	OK	

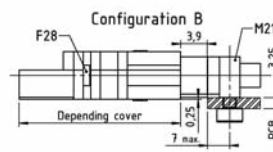
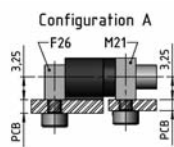

Recommended Torque : 0,2 N/m







FIXING HARDWARE FOR CMM 220 MALE

REFERENCE	ASSEMBLY ON PCB	OVERALL DIMENSIONS	RECOMMENDATION
F27			F27 : CMM male : Card edge for HF contact 30-1500-CMM
F34			F34 : CMM male : Card edge LF contact or mixed
F28			F28 : CMM male : S-C (E : straight)

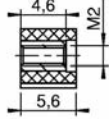
Please refer to the CMM Catalogue Guidelines for any other fixing not listed here.

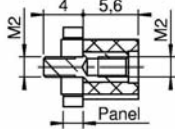
Fixing for CMM 220 male

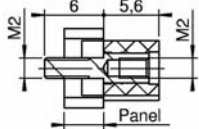
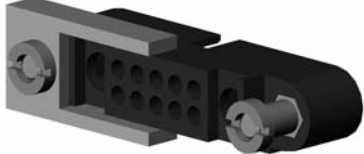
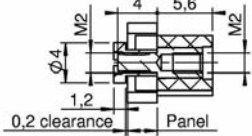
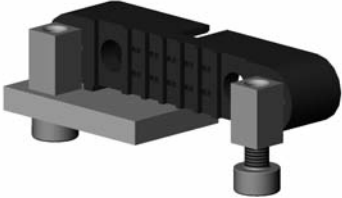
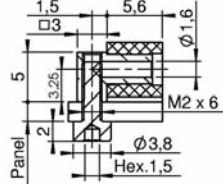
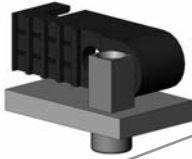
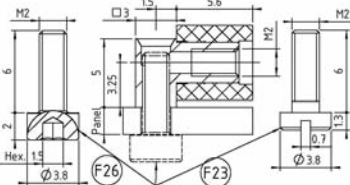
FIXING HARDWARE FOR CMM 220 MALE

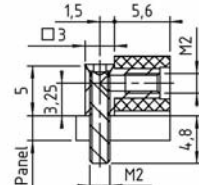
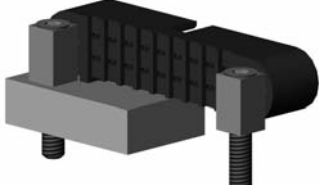
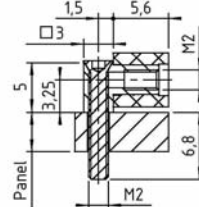
REFERENCE	ASSEMBLY ON PCB	OVERALL DIMENSIONS	RECOMMENDATION
F21	Straight on PCB 		F21 : CMM male : Y-YL-TS-C (D-E : straight)
F22	Straight on PCB 0,8 min / 2 max 		F22 : CMM male : Y-TS-C (D-E : straight)
F22H			F22H : CMM male : Y-T (D : straight)
F24	Straight on PCB 1,5 min / 4 max 		F24 : CMM male : YL-TS-C (D-E : straight)
F24H			F24H : CMM male : YL-T (D : straight)
F2xx xx = (PCB thickness + 0,2 mm) x 10 Example : for 3 mm PCB, the reference is F232 (3 + 0,2) x 10 = 32 xx = 32	Straight on PCB with floating option 		F2xx : CMM male : S-C (E : straight)
F25	90° on PCB 		F25 : CMM male : V-VL-R-S-C-E (D : 90°)
F26	90° on PCB 		F26/F23 : CMM male : V-VL-R-S-C-E (D : 90°)
F23			
F30	90° on PCB 2,5 max. 		F30 & F30H: CMM male : V-R-C-S-E (D : 90°)
F30H			
F31	90° on PCB 4,5 max. 		F31 & F31H: CMM male : VL-R-C-S-E (D : 90°)
F31H			

Please refer to the CMM Catalogue Guidelines for any other fixing not listed here.

Fixing for CMM 220 female

FIXING HARDWARE FOR CMM 220 FEMALE

HEXAGONAL NUT

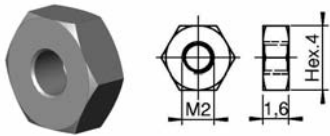

STANDARD NUT

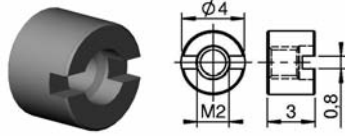

REFERENCE	ASSEMBLY ON PCB	OVERALL DIMENSIONS	RECOMMENDATION
M16 M11	Straight on PCB 		M16/M11 : CMM Female : Y-YL-TS-C-E (D : straight)
M12 M12H	Straight on PCB 0,8 min / 2 max 		M12 : CMM female : Y-TS-C (D-E : straight) M12H : CMM female : Y-T (D : straight)
M12L M12LH	Straight on PCB 1,5 min / 4 max 		M12L : CMM female : Y-TS-C (D-E : straight) M12LH : CMM female : YL-T (D : straight)
M1xx xx = (PCB thickness + 0,2 mm) x 10 Example : for 3 mm PCB, the reference is M132 (3 + 0,2) x 10 = 32 xx = 32	Straight on PCB with floating option 		M1xx : CMM female : S-C (E : straight)
M21 for PCB 1,6 mm (L = 4 mm) M21L for PCB 3,2 mm (L = 5 mm)	90° on PCB 		M21 : CMM Female : V-R-S-C-E (D : 90°) M21L : CMM Female : VL-R-S-C-E (D : 90°)
M18	Cover option 		M18 : CMM female : S-C (E : straight)

Please refer to the CMM Catalogue Guidelines for any other fixing not listed here.

Other fixing hardware for CMM 220

FIXING HARDWARE FOR CMM 220 FEMALE/MALE

HEXAGONAL NUT

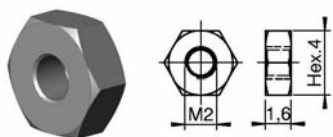

STANDARD NUT

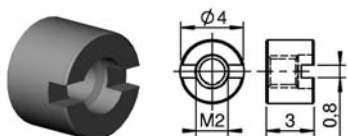

REFERENCE	ASSEMBLY ON PCB	OVERALL DIMENSIONS	RECOMMENDATION
M46	Straight on PCB 1,5 min. / 2,5 max. 		M46 : CMM female : Y-TS-C (D-E : straight) M46H : CMM female : Y-T (D : straight)
M46H			
M47	Straight on PCB 1,5 min. / 4 max. 		M47 : CMM female : YL-TS-C (D-E : straight) M47H : CMM female : YL-T (D : straight)
M47H			
M48 for PCB 1,6 mm (L = 3 mm)	90° on PCB 		M48 / M48M / M48L : CMM female : V-VL-R-S-C-E (D : 90°)
M48M for PCB 2 mm (L = 4 mm)			
M48L for PCB 3,2 mm (L = 5 mm)			
F60	Straight on PCB 		F60 : CMM male : Y-YL-TS-C-E (D : straight)
F61	Straight on PCB 		F61 : CMM male : Y-YL-TS-C-E (D : straight)

M46 M46H M47 M47H
fixing hardware PCB layout

2 holes $\varnothing 2,8 \pm 0,05$

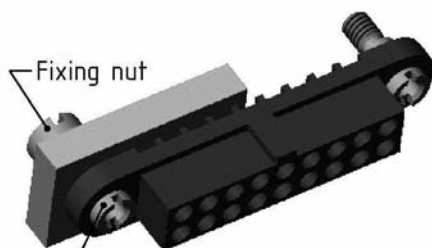
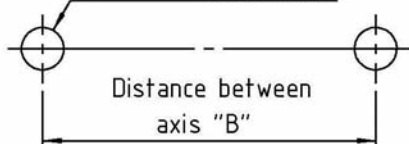

While screwing the fixing nut
maintain the insert with screwdriver