



UM608

Preliminary

LINEAR INTEGRATED CIRCUIT

CONSTANT VOLTAGE AND CONSTANT CURRENT CONTROLLER FOR BATTERY CHARGERS

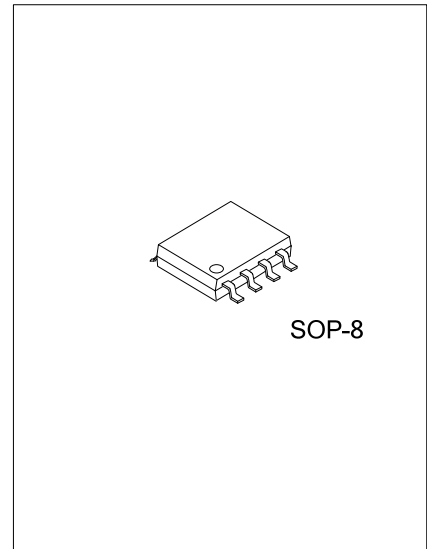

DESCRIPTION

The UTC **UM608** is a highly integrated solution for a constant voltage/constant current mode SMPS application.

The UTC **UM608** contains one 2.5V voltage reference, one operational amplifier for voltage control loop, one operational amplifier for current control loop and two operational amplifiers for charge status. It is suitable for battery charger and other battery systems.

FEATURES

- * Constant Voltage and Constant Current Control
- * Precision Internal Voltage Reference
- * Few External Components
- * Easy Compensation
- * Charge status output for LED
- * build-in overvoltage protection for battery

ORDERING INFORMATION

Ordering Number		Package	Packing
Lead Free	Halogen Free		
UM608L-S08-R	UM608G-S08-R	SOP-8	Tape Reel
UM608L-S08-T	UM608G-S08-T	SOP-8	Tube

Note: xx: Output Voltage, refer to Marking Information.

<p>UM608L-S08-R</p> <ul style="list-style-type: none"> (1) Packing Type (2) Package Type (3) Lead Free 	<ul style="list-style-type: none"> (1) R: Tape Reel, T: Tube (2) S08: SOP-8 (3) G: Halogen Free, L: Lead Free
---	--

■ PIN CONFIGURATION

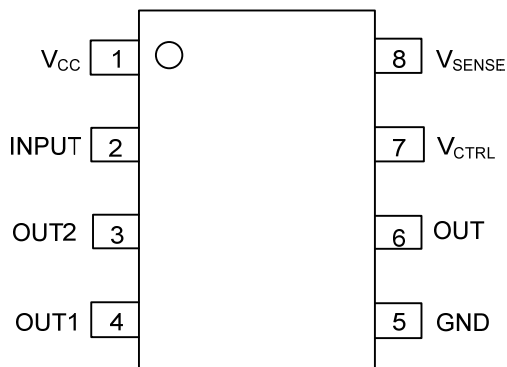

■ PIN DESCRIPTION

PIN NO.	PIN NAME	DESCRIPTION
1	V _{CC}	Power supply
2	INPUT	Input of charge status amplifier
3	OUT2	Charge status output
4	OUT1	Charge status output
5	GND	Ground
6	OUT	Output pin. Sinking current only
7	V _{CTRL}	Input pin of the voltage control loop
8	V _{SENSE}	Input pin of the current control loop

■ BLOCK DIAGRAM

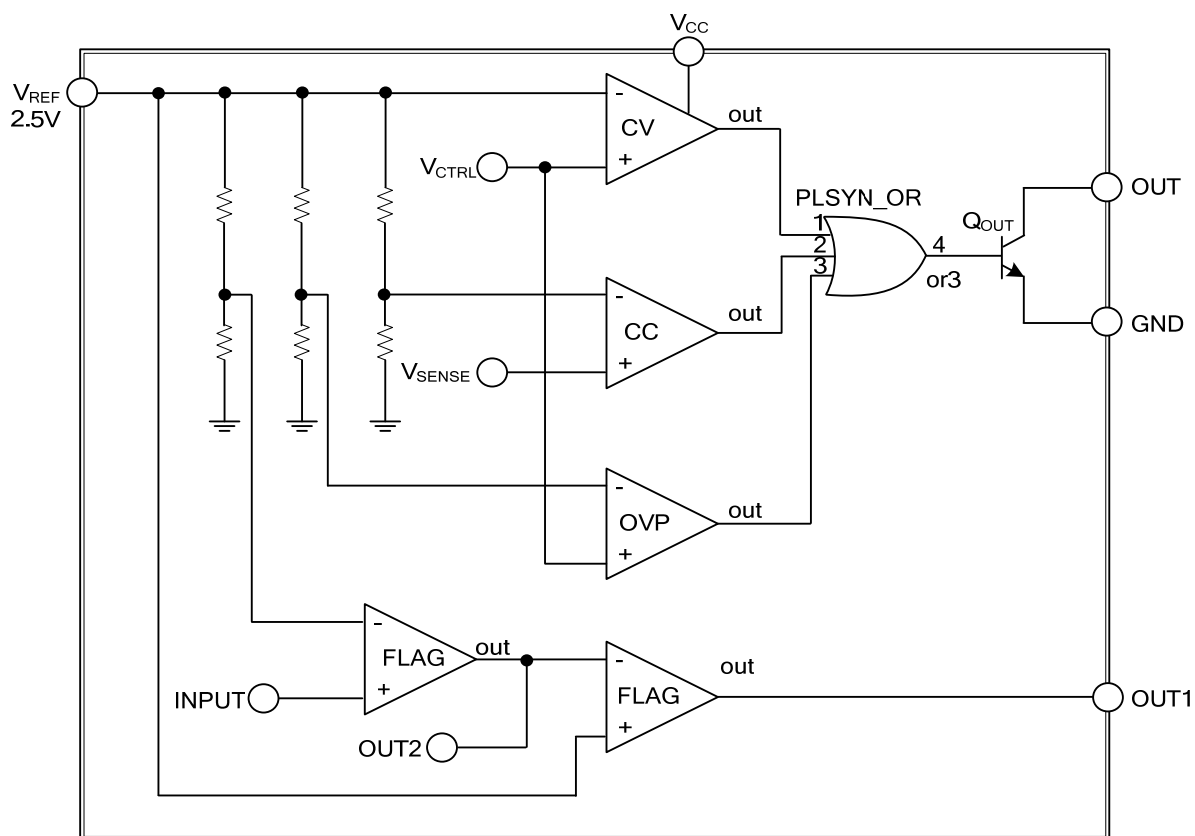

■ ABSOLUTE MAXIMUM RATING

PARAMETER	SYMBOL	RATINGS	UNIT
Power Supply Voltage	V_{CC}	35	V
Junction Temperature	T_J	150	°C
Operating Temperature	T_{OPR}	-40~+105	°C
Storage Temperature	T_{STG}	-65 ~ +150	°C

Note: Absolute maximum ratings are those values beyond which the device could be permanently damaged. Absolute maximum ratings are stress ratings only and functional device operation is not implied.

■ THERMAL DATA

PARAMETER	SYMBOL	RATINGS	UNIT
Junction to Ambient	θ_{JA}	150	°C/W

■ RECOMMENDED OPERATING CONDITIONS

PARAMETER	SYMBOL	RATINGS	UNIT
Voltage Operating	V_{CC}	5 ~ 32	V

■ ELECTRICAL CHARACTERISTICS ($V_{CC}=15V$, $T_A=25^\circ C$, unless otherwise specified)

PARAMETER	SYMBOL	TEST CONDITIONS	MIN	TYP	MAX	UNIT
DEVICE SUPPLY						
Supply Current	I_{CC}	$V_{CC}=15V$		2	4	mA
VOLTAGE CONTROL LOOP						
Transconductance Gain (V_{CTRL})	G_{MV}	$I/(V1-V2)$	1	3.5		mA/mV
Voltage Control Loop Reference	V_{REF}			1.25		V
Input Bias Current	I_{IBV}			50		nA
CURRENT CONTROL LOOP						
Transconductance Gain (V_{SENSE})	G_{MI}	$I/(V1-V2)$	1.5	7		mA/mV
Current Control Loop Reference	V_{SENSE}			190		mV
OUTPUT OF VOLTAGE AND CURRENT CONTROL LOOP						
Low Output Voltage at 10mA Sinking Current	V_{OL}			200		mV
Max Output Current	I_{OM}	Output to V_{CC} sink current only		27	50	mA
OUTPUT OF CHARGE SUTUS						
High Output Voltage at 10mA Source Current	V_{OH}		13	13.5	14	V
Max Output Current	I_{OM}	Output to GND source current only		20	40	mA
Sense charge status	V_{REF}	Input of charge status amplifier		65		mV

■ TYPICAL APPLICATION CIRCUIT

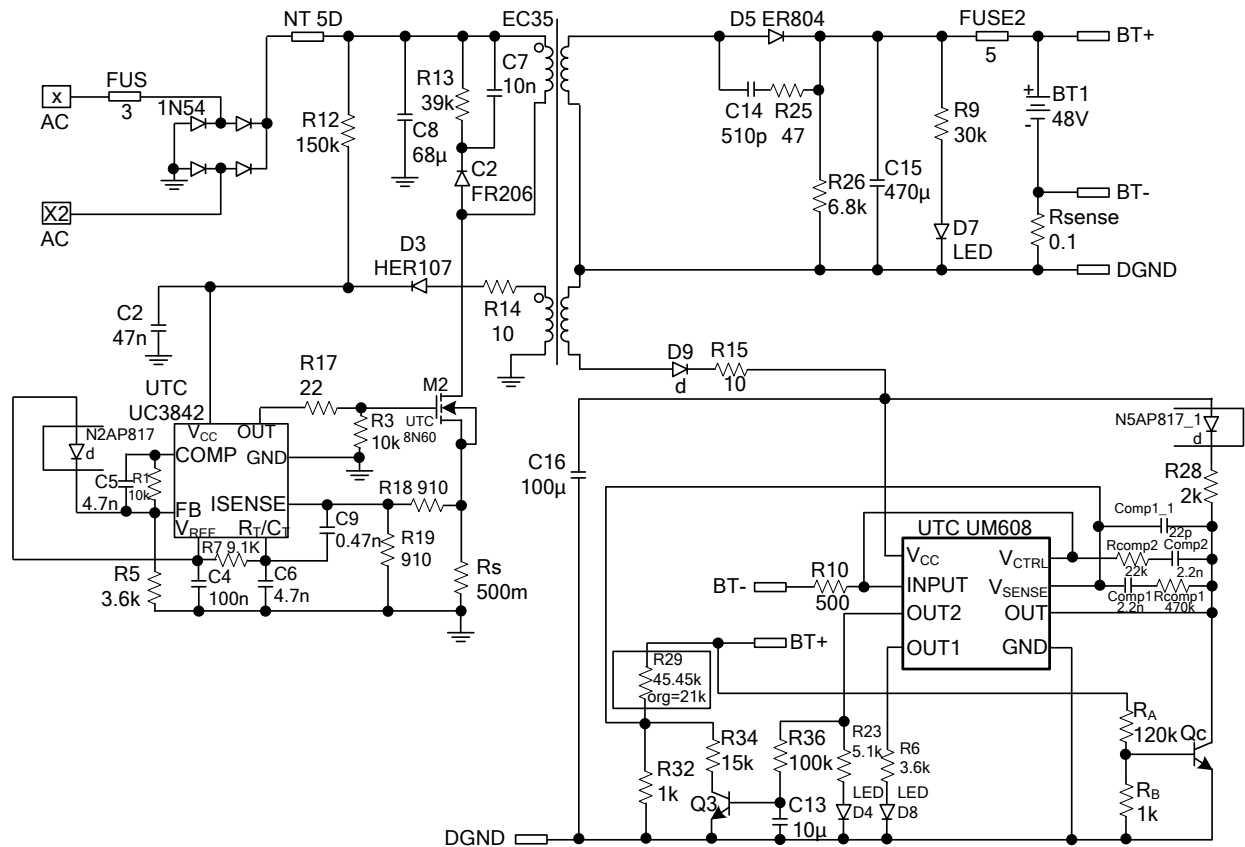

UTC assumes no responsibility for equipment failures that result from using products at values that exceed, even momentarily, rated values (such as maximum ratings, operating condition ranges, or other parameters) listed in products specifications of any and all UTC products described or contained herein. UTC products are not designed for use in life support appliances, devices or systems where malfunction of these products can be reasonably expected to result in personal injury. Reproduction in whole or in part is prohibited without the prior written consent of the copyright owner. The information presented in this document does not form part of any quotation or contract, is believed to be accurate and reliable and may be changed without notice.