

Thermatel® Model TD1/TD2

Installation and Operating Manual

Thermal Dispersion Flow/Level/Interface Switch



Model TD1
with twin-tip probe



Model TD2
with spherical probe



Model TD2
with low flow body



Model TD2
with hygienic stainless
steel enclosure
& spherical tip probe

Read this Manual Before Installing

This manual provides information on the Thermatel Thermal Dispersion Flow/Level Switch. It is important that all instructions are read carefully and followed in sequence. The *QuickStart Installation* instructions are a brief guide to the sequence of steps for experienced technicians to follow when installing the equipment. Detailed instructions are included in the *Complete Installation* section of this manual.

Conventions Used in this Manual

Certain conventions are used in this manual to convey specific types of information. General technical material, support data, and safety information are presented in narrative form. The following styles are used for notes, cautions, and warnings.

NOTES

Notes contain information that augments or clarifies an operating step. Notes do not normally contain actions. They follow the procedural steps to which they refer.

Cautions

Cautions alert the technician to special conditions that could injure personnel, damage equipment, or reduce a component's mechanical integrity. Cautions are also used to alert the technician to unsafe practices or the need for special protective equipment or specific materials. In this manual, a caution box indicates a potentially hazardous situation which, if not avoided, may result in minor or moderate injury.

WARNINGS

Warnings identify potentially dangerous situations or serious hazards. In this manual, a warning indicates an imminently hazardous situation which, if not avoided, could result in serious injury or death.

Safety Messages

The Thermatel system is rated by the IEC for use in Installation Category II, Pollution Degree 2. Follow all standard industry procedures for servicing electrical and computer equipment when working with or around high voltage. Always shut off the power supply before touching any components.

Electrical components are sensitive to electrostatic discharge. To prevent equipment damage, observe safety procedures when working with electrostatic sensitive components.

WARNING! Explosion hazard. Do not connect or disconnect equipment unless power has been switched off or the area is known to be non-hazardous.

Low Voltage Directive

For use in Installation Category II. If equipment is used in a manner not specified by the manufacturer, protection provided by equipment may be impaired.

Notice of Copyright and Limitations

Magnetrol & Magnetrol logotype, and Thermatel are registered trademarks of Magnetrol International.

Copyright © 2010 Magnetrol International, Incorporated. All rights reserved.

Performance specifications are effective with date of issue and are subject to change without notice. Magnetrol reserves the right to make changes to the product described in this manual at any time without notice. Magnetrol makes no warranty with respect to the accuracy of the information in this manual.

Warranty

All Magnetrol electronic level and flow controls are warranted free of defects in materials or workmanship for one full year from the date of original factory shipment. If returned within the warranty period; and, upon factory inspection of the control, the cause of the claim is determined to be covered under the warranty; then, Magnetrol will repair or replace the control at no cost to the purchaser (or owner) other than transportation.

Magnetrol shall not be liable for misapplication, labor claims, direct or consequential damage or expense arising from the installation or use of equipment. There are no other warranties expressed or implied, except special written warranties covering some Magnetrol products.

Quality Assurance

The quality assurance system in place at Magnetrol guarantees the highest level of quality throughout the company. Magnetrol is committed to providing full customer satisfaction both in quality products and quality service.

Magnetrol's quality assurance system is registered to ISO 9001 affirming its commitment to known international quality standards providing the strongest assurance of product/service quality available.





Thermatel Model TD1/TD2 Thermal Dispersion Flow/Level Switch

Table of Contents

1.0 Quick Start	
2.0 Installation	
2.1 Unpacking	4
2.2 Electrostatic Discharge (ESD) Handling Procedure	4
2.3 Mounting	5
2.4 Wiring	6
2.4.1 Relay Connections	7
2.4.2 Remote Electronics Wiring (TD2 only)	8
2.4.3 mA Output Wiring (TD2 only)	8
2.5 Setup	9
2.5.1 Switch Settings	9
2.5.2 LED Operation	10
2.5.3 LED Initialization	10
2.5.4 Time Delay (TD2 only)	10
2.6 Calibration	11
2.6.1 Adjustment Procedure for LEVEL Applications	11
2.6.1.1 Unable to Change Level	13
2.6.2 Adjustment Procedure LOW FLOW/NO FLOW	13
2.6.3 Adjustment Procedure for HIGH FLOW Detection	14
2.6.3.1 Unable to Change Flow Rate	14
2.6.4 Advanced Calibration Procedure (TD2)	15
3.0 Reference Information	
3.1 Description	16
3.2 Theory of Operation	16
3.3 Fault Detection	17
3.4 Resistance Values	17
3.5 Troubleshooting	18
3.6 Maintenance	19
3.6.1 Cleaning	19
3.6.2 Probe Replacement	19
3.6.2.1 Integral Electronics	19
3.6.2.2 Remote Electronics (TD2)	20
3.7 Agency Approvals	21
3.8 Replacement Parts	22
3.8.1 Model TD1	22
3.8.2 Model TD2	23
3.9 Specifications	24
3.9.1 Performance	24
3.9.2 Probe	25
3.9.3 Physical	26
3.10 Model Numbers	27
3.10.1 Model TD1	27
3.10.2 Model TD2	27
3.10.3 Standard Probe	28
3.10.4 High Temperature Probe	29
3.10.5 Low Flow Body	30
3.10.6 Mini Sensor	30
3.10.7 Connecting Cable	31

1.0 Quick Start

Unless ordered with factory calibration, the set point of the unit must be adjusted for your application.

To calibrate, adjust the alarm set point potentiometer. Turn the potentiometer clockwise to go out of alarm. Turn potentiometer counterclockwise to cause the switch to go into alarm (red LED on). Refer to the Calibration section on page 11 for detailed procedure.

2.0 Installation

2.1 Unpacking

Unpack the instrument carefully, making sure all components have been removed from the packing material. Inspect all components for damage, and report any concealed damage to the carrier within 24 hours.

Check the contents of the carton, making sure it agrees with the packing slip and the purchase order. Verify that the model number imprinted on the nameplate matches the number on the packing slip and the purchase order. Report any discrepancies to the factory. Check and record the serial number for future reference when ordering parts.

Serial Number

2.2 Electrostatic Discharge (ESD) Handling Procedure

Magnetrol's electronic instruments are manufactured to the highest quality standards. These instruments utilize electronic components which may be damaged by static electricity present in most work environments. The following steps are recommended to reduce the risk of component failure due to electrostatic discharge:

1. Ship and store circuit boards in anti-static bags. If an anti-static bag is not available, wrap board in aluminum foil. Do not place boards on foam packing materials.
2. Use a grounding wrist strap when installing and removing circuit boards. A grounded workstation is also recommended.
3. Handle printed circuit boards only by the edges. Do not touch components or connector pins.
4. Ensure that all electrical connections are completely made and none are partial or floating. Ground all equipment to a good, earth ground.

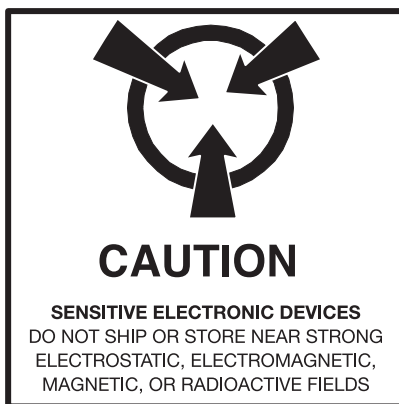

2.3 Mounting

Thermatel Flow/Level Switches are shipped assembled to the sensor. Units may be mounted in any position or orientation. Refer to Figures 1 and 2.

Thermatel Flow/Level Switches should be located to allow easy access for service. During operation the electronics should not be exposed to ambient temperature above +158° F (+70° C) or below -40° F (-40° C). Special precaution should be taken to prevent exposure to corrosive atmosphere, excessive vibration, shock or physical damage. The switch can be exposed to storage temperature of -58° F (-50° C).

NOTE: All wiring, conduit and electrical fittings must conform to local electrical codes for the location selected.

The Thermatel Flow/Level Switch has a standard $\frac{3}{4}$ " NPT mount designed for easy installation through a threaded connection. Optional threaded and flanged connections are also available.

1. Apply thread sealant to the sensor and insert the sensor into the threaded connection.

Caution: Tighten unit only at the wrench flats on the sensor using an open-end wrench. DO NOT use the instrument head to tighten the switch to the mounting port. Rotation of the instrument head with respect to the sensor assembly can cause internal wiring damage.

2. Make sure the sensor is properly oriented to the flow (refer to Figures 3 and 4) or level (refer to Figure 5).

Caution: The switch body must be oriented so that the flow arrow is in the direction of the flow/level being detected. Proper orientation is marked on the wrench flats or on the top of the flange for reference.

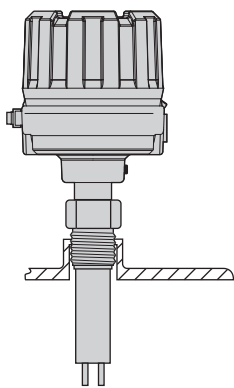

Figure 1
Mounting

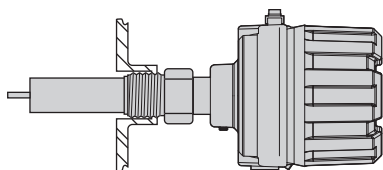

Figure 2
Mounting

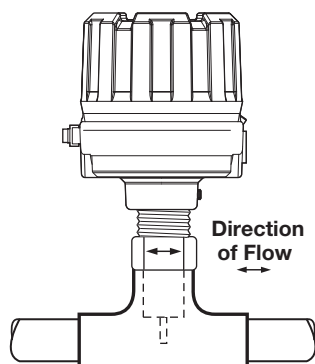
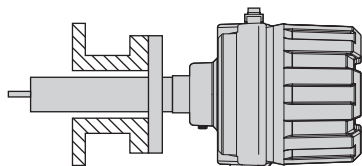

Figure 3
Tee Connection

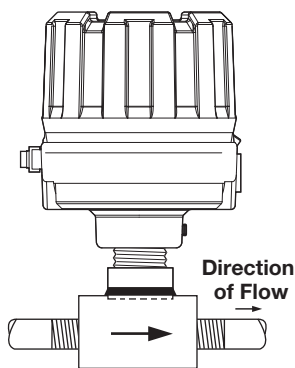

Figure 4
Low Flow Body

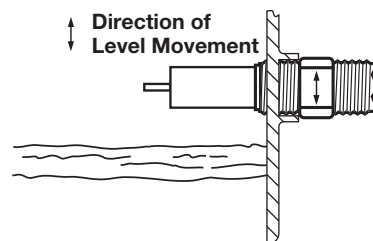

Figure 5
Level

2.4 Wiring

The wiring connections for the power and relay are suitable for 12–24 AWG wire.

Caution: OBSERVE ALL APPLICABLE ELECTRICAL CODES AND PROPER WIRING PROCEDURES.

1. Make sure the power source is turned off.
2. Unscrew and remove housing cover.
3. Pull power supply and control wires through conduit connection.
4. Connect power leads to proper terminals. Refer to Figure 6 for TD1 or Figure 7 for TD2 electronics. Note that the TD1 is only available with 24 VDC input power. The TD2 is available for AC power (100 to 260 VAC) or as a DC power (19.2 to 28.8 VDC).
 - a. AC power – Connect “hot” wire to terminal marked L1 and the “neutral” wire to the terminal marked L2/N (TD2 Only). The green screw should be used for grounding.
 - b. DC Power – Connect wires to terminals (+) and (-) on the terminal block. Unshielded cable can be utilized.
5. Perform Relay Connections (refer to Figure 6 for TD1 or Figure 7 for TD2 electronics).
6. Prevent moisture seepage into housing by installing an approved seal drain fitting in the conduit run leading to the unit.
7. Installation is complete. Replace housing cover.

Caution: In hazardous areas, do not power the unit until the conduit is sealed and enclosure cover is screwed down securely.

NOTE: For supply connections use wire with a minimum rating of +75° C, as required by process conditions. Use a minimum of 12–16 AWG wire for power and ground field wires.

NOTE: An approved disconnect device and current limiting device or circuit breaker, maximum 15A shall be installed in close proximity to equipment and within easy reach of operator. It shall be marked as the disconnecting device for the equipment.

NOTE: Housing must be grounded via protective ground screw in the base of the housing.

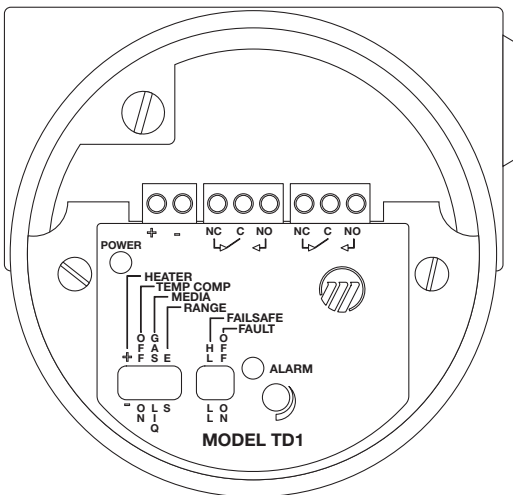

Figure 6
TD1 Wiring

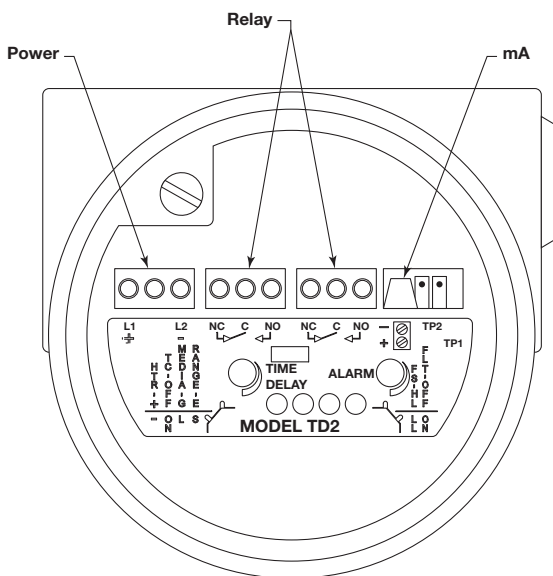

Figure 7
TD2 Wiring

2.4.1 Relay Connections

TD1/TD2:

DPDT

8 amp at 120–250 VAC

8 amp at 30 VDC, 0.5 amp at 125 VDC resistive

TD2 with Hermetically sealed relay:

DPDT 1 amp at 28 VDC, 0.5 amp at 125 VDC resistive

The switch may be configured so that the relay either energizes or de-energizes when the set point is reached. Locating the fail-safe switch in the LL position places the switch in a low level fail-safe (LLFS) position. This causes the relay to energize when the flow rate is higher than the set point or when the sensor is immersed. Locating the fail-safe switch in the HL position places the switch in a high level fail-safe (HLFS) position. This causes the relay to energize when the flow rate is less than the set point or when the sensor is dry. Refer to the following chart.

Power	Flow Level	Fail-Safe Position	Relay Coil	Relay Terminal	
				NC to CO	NO to CO
On	High	HLFS	De-energized	Closed	Open
		LLFS	Energized	Open	Closed
On	Low	HLFS	Energized	Open	Closed
		LLFS	De-energized	Closed	Open
Fail	High	HLFS	De-energized	Closed	Open
		LLFS	De-energized	Closed	Open
Fail	Low	HLFS	De-energized	Closed	Open
		LLFS	De-energized	Closed	Open

Chart Notes and Definitions

1. Equipment controlled by the Thermatel relay is assumed to be powered from one source, while the Thermatel unit itself is assumed to be powered from a different source.
2. “Fail” means a loss of power to the Thermatel unit.
3. HL means a flow rate or level which is above the adjusted set point.
4. LL means a flow rate or level which is less than the adjusted set point.
5. When the relay coil is de-energized, a connection is made between the terminals CO (common) and NC (normally closed), and there is no connection between CO and NO (normally open).
6. When the relay coil is energized, a connection is made between the terminals CO and NO, and there is no connection between CO and NC.

2.4.2 Remote Electronics Wiring (TD2 only)

When using remote electronics, the sensor and electronic circuit board are contained in separate enclosures. A six conductor shielded cable is required for connection between the enclosures.

The cable is routed to the electronic circuit board and connected to the green, 6-position terminal block (TB4). The cable's six conductors are connected to terminals 1 through 6. The cable shield should be connected to the green ground screw in the sensor housing. If the cable is supplied by Magnetrol, then this connection is pre-wired at the circuit board. The user only needs to connect the wiring at the terminal connection on the sensor enclosure.

If cable is supplied by user, remove bezel by placing screwdriver blade in slot in center of bezel and gently pull the handle away from the terminal strips. Then remove screws and lift out the electronic module. Attach the cable wiring as shown in Figure 8.

The sensor enclosure includes a 6-position terminal block for connecting a shielded 6-conductor cable. The cable's six conductors are connected to terminals 1 through 6 in the sensor enclosure. The cable shield is connected to the green ground screw. Refer to Figure 8 for the pin numbers.

NOTE: The six conductors must be wired so that each terminal on the sensor terminal block TB4 (see Figure 8) is connected to its corresponding terminal on the electronic circuit board. Failure to do so will cause improper switch operation.

2.4.3 mA Output Wiring (TD2 only)

The TD2 will output a mA signal which can be used for diagnostics or to provide trend indication from the switch. This mA output represents the sensor signal. The signal cannot be scaled by the user. The output is proportional to the flow rate. The range of outputs will vary for each unit due to differences in probes. The range of the mA output is also dependent upon the switch setting (section 2.5).

The mA output can also be used for fault detection. In the event of a fault, the mA output will be greater than 22 mA if HLFS is selected or less than 3.6 mA if LLFS is selected.

The mA output is isolated from the input power.

Wiring of the mA output is shown in Figure 7 on page 6. Wiring should be 16 to 26 AWG.

NOTE: Due to ATEX requirements, the mA output is not provided on the TD2-XD0X-XCX.

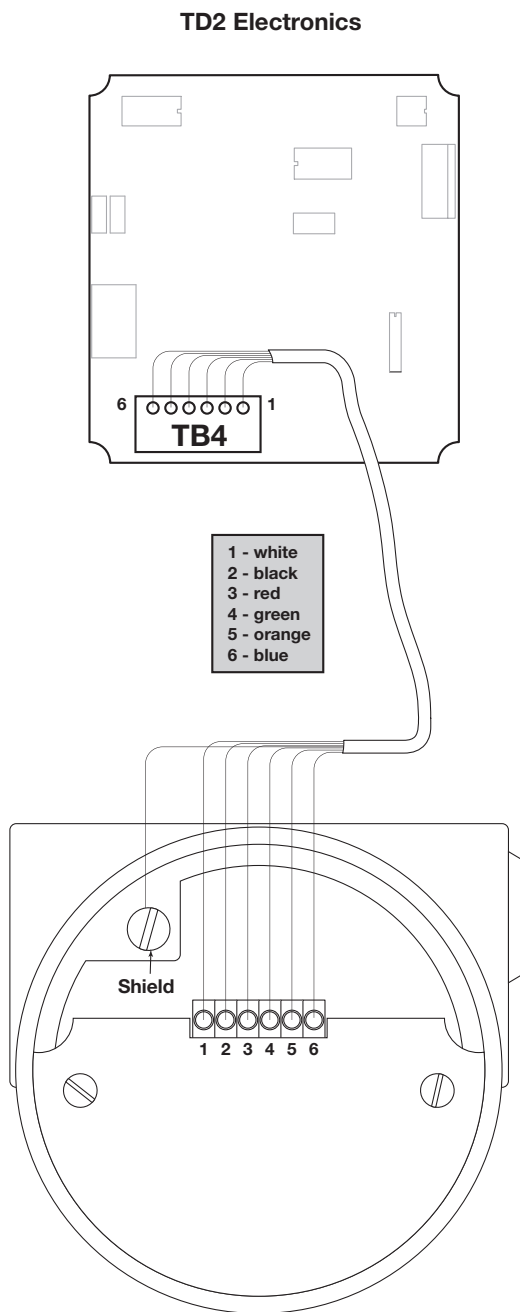

Sensor Enclosure
Figure 8

2.5 Setup

2.5.1 Switch Settings

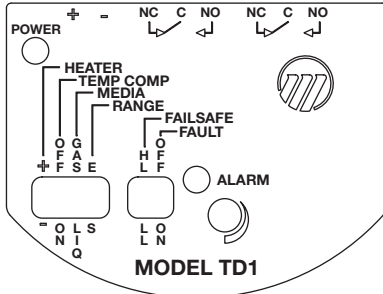

Figure 9
TD1

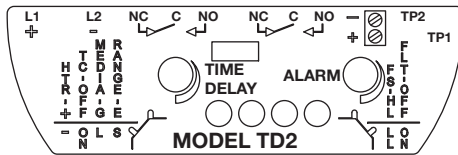

Figure 10
TD2

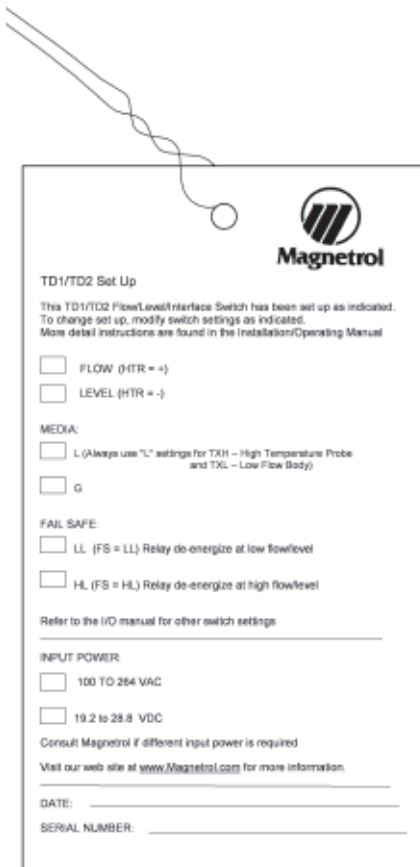

Figure 11
TD1/TD2 Setup Tag

The TD1 and TD2 have a series of switches which may require field adjustment depending upon the application. Switch position for the TD1 is shown in Figure 9 and switch position of the TD2 is shown in Figure 10.

There are two sets of switches on the TD1/TD2. One set has 4 switches, the second set has two switches.

The switch settings are set at Magnetrol during setup. Changes in the positions may be required in the field depending upon the application. There is a tag wired onto the switch which indicates the default settings. See Figure 11. Use the following table for recommended switch settings.

Four-position Switch

Switch	Purpose	Options	
Heater	Control heat to sensor	See sensor table below	Default is "+"
Temperature Compensation	ON/OFF	See sensor table below	Default is "on"
Media	Gas/liquid	Select	Default is liquid "L" Use gas "G" position only for gas flow applications
Range	Expand sensitivity for water flow applications	Switch to "E" position for water flow applications to improve sensitivity	Default is "S"

Two-position Switch

Fail-safe	HL = High Level Fail-safe LL = Low Level Fail-safe
Fault detection	Should be on (some applications may require that this be turned off, see Section 3.5).

Sensor

Sensor	Application	Heater	TempComp	Media
Spherical Tip (TXA, TXB)	Liquid Flow	+	on	L
	Gas Flow	+*	on	G
	Level	-	on	L
Twin Tip (TXC, TXD)	Liquid Flow	+	on	L
	Gas Flow	+*	on	G
	Level	-	on	L
HTHP (TXH)	Liquid Flow	+	on	L
	Gas Flow	+	on	L**
	Level	-	on	L
Flow Body (TXL)	Liquid Flow	+	on	L
	Gas Flow	+	on	L*

* Applications at no flow or low flow should be set with heater to "-".

** For best results use "L" setting for HTHP probe and low flow body.

2.5.2 LED Operation

TD1 – Two LEDs (Green & Red)

- Green LED glows when power is on.
- Red LED, glows when an alarm condition exists. The LED operation is independent of relay operation.
- The red LED will blink rapidly if the switch detects a fault. It will blink slowly during initial power-on.

TD2 – Four LEDs (Red, Yellow, & 2 Green)

LEDs indicate alarm status and fault indication. The LED operation is independent of relay operation.

- Red LED glows when an alarm condition exists. It will blink if the switch detects a fault.
- Yellow LED glows when approaching an alarm condition
- Green LEDs glow as the actual condition is further away from the alarm set point. This represents a safe mode.

2.5.3 LED Initialization

The TD1/TD2 has an initializing period to allow the sensor to heat up.

TD1 – The red LED will blink slowly during the initialization period.

TD2 – All LEDs will turn on then individually turn off. When complete the TD2 will resume normal operation.

2.5.4 Time delay (TD2 only)

Turning the time delay potentiometer clockwise increases response time. This adjustment adds time delay in addition to the sensor response time. Generally this is set to full counterclockwise position unless additional time delay is required due to pulsating flow, turbulence, or splashing.

If time delay is used, the red alarm LED will first illuminate when an alarm condition occurs, the relay activation will occur after the appropriate time delay. Time delay occurs while going into alarm. There is no time delay (other than sensor response time) coming out of alarm.

2.6 Calibration

Calibration must be performed using the actual fluid. The switch detects the cooling capabilities of the media. Calibrating the switch in a different media may change the set point.

NOTE: Set the switches (Section 2.5.1) to the desired position before performing the calibration. Changing the Heater, Range, Fail-safe, or Temperature Compensation settings will affect the set point.

Select the fail-safe mode (HL or LL) before performing the calibration. The fail-safe selection does affect the calibration set point.

Turning the alarm potentiometer clockwise to go from an alarm condition to the normal (safe) condition. Turn the alarm potentiometer counterclockwise to go into alarm.

NOTE: The LED operation changes with the fail-safe mode selection. The red LED is illuminated when an alarm condition exists.

High Level Fail-safe

HLFS – The switch goes into alarm under a wet (high level) condition or if the flow rate has increased above the set point. On the TD2, the green and yellow LEDs will be on at low flows or low level indicating a normal condition. The number of green LEDs illuminated will decrease as the flow rate increases.

Low Level Fail-safe

LLFS – The switch goes into alarm under a dry (low level) condition or if the flow rate has dropped below the set point. On the TD2, the green and yellow LEDs will be on at high flow rates or high level indicating a normal condition. The number of green LEDs illuminated will decrease as the flow rate decreases.

2.6.1 Adjustment Procedure for LEVEL Applications

1. Place HTR Switch in "-" position (↖).
2. Set desired fail-safe condition.
3. Ensure time delay potentiometer (TD2 only) is fully counterclockwise (rotate 30 turns or until clicks are heard).
4. Immerse in still liquid. Wait a minimum of 3 minutes for the sensor to stabilize. (On the TD2, the mA output can be monitored to determine when stable).

Follow procedure below for either High Level, Low Level, or interface applications.

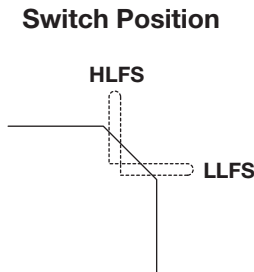
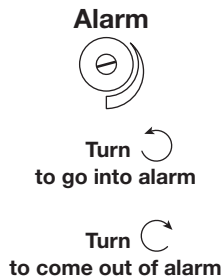

**High Level Adjustment
(High Level Fail-safe)**



Turn 
for faster response to detect
a high level (wet) condition

5a. High Level Applications

- a. Set fail-safe switch to the “HL” position (switch up ).
- b. Turn alarm potentiometer counterclockwise until red LED turns on.
- c. Turn alarm potentiometer clockwise until red LED turns off.
- d. Repeat steps b and c several times leaving the red LED on.
- e. Turn alarm potentiometer counterclockwise one additional turn.
- f. Remove from the liquid. The switch will reset.
- g. Put back in liquid. If response time to detect level is too long then turn one half turn counterclockwise and retest.

Turn alarm potentiometer counterclockwise for the switch to respond quicker to detect level. Turn alarm potentiometer clockwise to decrease time to detect dry condition.

5b. Low Level applications

- a. Set fail-safe switch to the “LL” position (switch down ).
- b. Turn alarm potentiometer counterclockwise until red LED turns on.
- c. Turn alarm potentiometer clockwise until red LED turns off.
- d. Repeat steps b and c several times leaving the red LED off.
- e. Turn alarm potentiometer clockwise $\frac{1}{2}$ additional turn.
- f. Remove from the liquid. If the response time to detect a dry condition is too long, turn the alarm potentiometer counterclockwise and retest.

**Low Level Adjustment
(Low Level Fail-safe)**



Turn 
for faster response to detect
a low level (dry) condition

5c. Interface applications

Follow either of the procedures above substituting the oil (or low thermal conductive fluid) for the dry condition and water (or high thermal conductivity fluid) for the wet condition.

6. The switch will typically detect level within 3 to 5 seconds and detect a dry condition within 5 to 10 seconds. This depends upon set point adjustment and type of sensor.

Typical Switch Settings:

(See page 9 for detail settings)

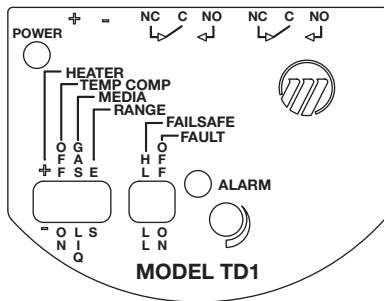

Figure 9
TD1

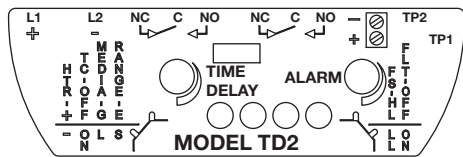



Figure 10
TD2

TD1	TD2		
Heater	HTR	+	Flow Applications
		-	Level Applications
Temp Comp	TC	ON	
Media	Media	G	Gas
		L	Liquid Flow and Level HTHP and low flow body
Range	Range	S	Standard (default)
		E	Expanded
Fail Safe	FS	HL	High Level
		LL	Low Level
Fault	FLT	OFF	
		ON	Default

Low Flow Adjustment (Low Level Fail-safe)



Turn 
Faster response to
low flow or decrease
alarm point

Turn 
Faster response to
reset or increase
alarm point

2.6.1.1 Unable to Change Level

- **Low Level:** Follow the procedures in Step 5b, steps a–e on page 12. Any change in media will cause a low level alarm indication.
- **High Level:**
 1. Ensure that the sensor is located above the level of the fluid.
 2. Set Fail-safe to the “HL” position (↖).
 3. Turn alarm potentiometer counterclockwise until the red LED goes on.
 4. Turn alarm potentiometer clockwise until red LED goes off. If unable to get the red LED to turn off, change the HTR position to “-”.
 5. Repeat steps 3 and 4 several times leaving the red LED off. Turn potentiometer ½ additional turn clockwise.
 6. Any change in media will cause the switch to go into alarm.

NOTE: The time to reset may be lengthy. This time can be decreased by turning the potentiometer clockwise.

2.6.2 Adjustment Procedure LOW FLOW/NO FLOW

1. Put HTR Switch in the “+” position (↖).
2. Place Fail-safe in the “LL” position (↙).
3. Reduce the flow rate to the desired alarm point. Allow 3 minutes for the sensor to stabilize.
4. Rotate alarm potentiometer clockwise until the red LED turns off.
5. Rotate alarm potentiometer counterclockwise until the red LED turns on.
6. Repeat steps 4 and 5 several times leaving the red LED in the “on” position.
7. Resume full flow. The alarm should reset.
8. Reduce flow to no flow or the desired alarm point. If the response time required to alarm is too long, rotate alarm potentiometer counterclockwise ½ turn and test again.
9. If the response time required to sense flow is too long, rotate the alarm potentiometer clockwise ½ turn and test again.
10. Repeat steps 8 and 9 until desired response times for flow and no flow are attained. Normal delays range from two seconds to over fifteen seconds, depending on the fluid and the flow rate.

2.6.3 Adjustment Procedure – HIGH FLOW Detection

1. Place Fail-safe in the “HL” position (↖).
2. Increase the flow rate to desired alarm point. Allow 3 minutes for the sensor to stabilize.
3. Rotate alarm potentiometer counterclockwise until the red LED turns on.
4. Rotate alarm potentiometer clockwise until the red LED goes out.
5. Repeat steps 4 and 5 several times leaving the red LED in the “on” position.
6. Reduce flow to normal condition, the alarm should reset.
7. Increase flow to the desired alarm point. If the response time required to detect high flow is too long, rotate alarm potentiometer counterclockwise ½ turn and test again.

2.6.3.1 Unable to Change Flow Rate

1. Maintain flow rate at normal operating conditions. Allow 3 minutes for the sensor to stabilize.
2. Follow the procedures below for Low Flow Alarm or High Flow Alarm.

Low Flow Alarm

- a. Set fail-safe to “LL” position (↘).
- b. Rotate alarm potentiometer counterclockwise until the red LED turns on.
- c. Rotate alarm potentiometer clockwise until the red LED goes out.
- d. Repeat steps b and c several times leaving the LED in the off position. Continue to rotate the potentiometer ½ turn clockwise. The set point is now just below the present flow rate. When the flow rate drops below the present flow rate the red LED will turn on and the relay will de-energize.

High Flow Alarm

- a. Set fail-safe to “HL” position (↖).
- b. Rotate alarm potentiometer counterclockwise until the red LED turns on.
- c. Rotate alarm potentiometer clockwise until the red LED goes out.
- d. Repeat steps b and c several times leaving the LED in the "off" position. Continue to rotate the potentiometer ½ turn clockwise. The set point is now just higher than the present flow rate. When the flow rate increases above the present flow rate the red LED will turn on and the relay will de-energize.

High Flow Adjustment (High Level Fail-safe)



Turn ↺
Faster alarm or
decrease alarm point

Turn ↻
Faster reset or
increase alarm point

2.6.4 Advanced Calibration Procedure (TD2 only)

Measure and record the voltage between TP1 and TP2. This voltage will change as the set point potentiometer is adjusted. Voltage readings will be between 0 and 5 VDC. This value may be used for future reference or adjustment of set point. This value can be recorded and checked in the future to ensure that the set point has not changed since last calibration.

NOTE: Due to ATEX requirements, these test points (TP1 and TP2) are not provided on the TD2-XD0X-XCX.

3.0 Reference Information

3.1 Description

Thermatel TD1/TD2 switches are used for flow, level, and interface detection and control. Level detection is accomplished by sensing changes in the heat transfer characteristics of the media. Flow detection is accomplished by sensing changes in heat transfer caused by the flowing media.

The TD1 is the basic version while the TD2 offers advanced options including LED indication of flow/level, optional remote electronics, mA output representing the sensor signal, time delay, and a voltage signal representing the set point of the unit.

Sensors are available in 316/316L stainless steel, Hastelloy® C, or Monel® welded construction. The easy to install and adjust units provide reliable, low maintenance performance in the most demanding applications.

Both switches have continuous diagnostics to detect a failure of the sensor. This is accomplished by continuously monitoring the signal from the sensor which must remain within set levels. In the event the switch detects a fault, the relay will de-energize and the red LED will blink.

3.2 Theory of Operation

The Thermatel Flow/Level Switch consists of a dual element sensing assembly mounted integrally to the electronics, or the sensor may be remote mounted up to 500 feet (150 meters) from the electronics (TD2 only).

Each element of the sensor is a miniature RTD (Resistance Temperature Detector). One element measures the temperature of the process, providing a reference temperature. The second RTD is self-heated to establish a temperature differential above the reference temperature. The cooling effect on the heated RTD, caused by the presence of flow or level, decreases the differential temperature between the two RTDs. When the temperature difference reaches the set point, the relay will change state. Sensor designs are suitable for operation in temperatures of -100° to +850° F (-73° to +454° C).

3.3 Fault Detection

The TD1 and TD2 have continuous self diagnostics to ensure the signal from the sensor is within a select range. If the electronics detect an out of range signal, the switch will go into fault mode.

In the event of a fault, the red LED will blink and the relay will de-energize. In the TD2, the mA output will go to less than 3.6 mA if low level fail-safe is selected or greater than 22 mA if high level fail-safe is detected.

If a fault is detected, refer to *3.5 Troubleshooting*.

3.4 Resistance Values

The following tables provide the expected resistance values for the sensor. Refer to the indicated figures for pin locations.

Refer to *3.6.2 Probe Replacement* for removing bezel and circuit boards.

TD1 (see Figure 12)

Pin	Expected Resistance
1 to 3	90 to 180 ohms (275 ohms with high temperature probe)
2 to 4	90 to 180 ohms (275 ohms with high temperature probe)

TD2 – Integral Electronics (see Figure 13)

TD2 – Remote Electronic Enclosure (see Figure 14)

Pin	Expected Resistance
1 to 3 or 4	90 to 180 ohms (90 to 275 ohms with high temperature probe)
2 to 5 or 6	90 to 180 ohms (90 to 275 ohms with high temperature probe)
1 to 2, 3 to 4, 5 to 6	0 to 12 ohms

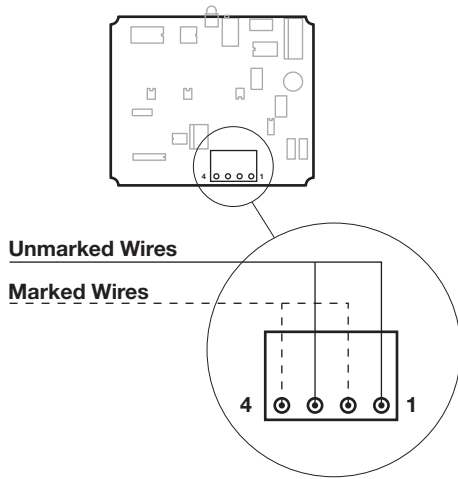

Figure 12
TD1 Probe Connections

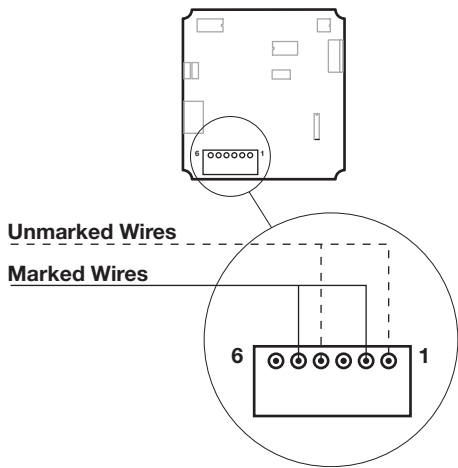

Figure 13
TD2 Probe Connections

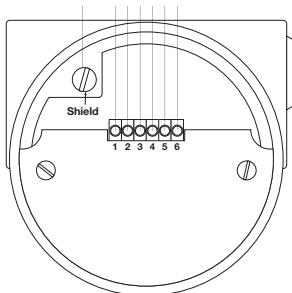

Figure 14
TD2 Remote Probe Connections

3.5 Troubleshooting

The TD1/TD2 switches have various settings to handle a wide variety of flow and level applications. If the switch is not performing properly, check the switch settings on page 9 or the following:

Symptom	Application	Action
Unable to adjust set point to obtain alarm Fault LED blinks	Air Flow Detection	Ensure that the probe is extended into the flow Change HEATER (Model TD1) / HTR (Model TD2) to “-”
Switch indicates a fault (red LED will blink)	Liquid Level – Sensor Wet	Verify HEATER (TD1) / HTR (TD2) is set to “-” Change HEATER/HTR to “+” Light goes off—contact factory to discuss application Light stays on—check resistance to determine if a problem exists with the probe or electronics. Refer to Section 3.4, Resistance Values on page 17. Probe and/or electronics may need to be replaced.
	Liquid Level – Sensor Dry	Verify HEATER (TD1) / HTR (TD2) is set to “-” Turn off FAULT (TD1) / FLT (TD2) Light goes off—operate in this mode Light stays on—check resistance to determine if a problem exists with the probe or electronics. Refer to Section 3.4, Resistance Values on page 17. Probe and/or electronics may need to be replaced.
	Liquid Flow – Sensor Dry or Air Flow – None	Turn off FAULT (TD1) / FLT (TD2) Light goes off—run HEATER/HTR at “+” and FAULT/FLT “off” or run HEATER/HTR at “-” Light stays on—check resistance to determine if a problem exists with the probe or electronics. Refer to Section 3.4, Resistance Values on page 17. Probe and/or electronics may need to be replaced.
	Liquid Flow – Sensor Wet No Flow	Switch HEATER/HTR to “-” Light goes off—run HEATER/HTR at “+” and FAULT/FLT “off” or run HEATER/HTR at “-” Light stays on—check resistance to determine if a problem exists with the probe or electronics. Refer to Section 3.4, Resistance Values on page 17. Probe and/or electronics may need to be replaced.
	Liquid Flow – Flow Present	Turn off TEMP COMP (TD1) / TC (TD2) Light goes off—operate in this mode Light stays on—check resistance to determine if a problem exists with the probe or electronics. Refer to Section 3.4, Resistance Values on page 17. Probe and/or electronics may need to be replaced.
	Air Flow – Flow Present	Switch HEATER/HTR to “-” Light goes off—Operate at lower heater power (with less sensitivity). Turn TEMP COMP/TC off if problem continues (requires re-calibration) or operate at HEATER/HTR “+” and make sure FAULT/FLT switch is “off” Light stays on—Turn TEMP COMP/TC “off”. If light goes off then recalibrate and operate in this mode. If light stays on check resistance to determine if a problem exists with the probe or electronics. Refer to Section 3.4, Resistance Values on page 17. Probe and/or electronics may need to be replaced.

3.6 Maintenance

3.6.1 Cleaning

The probe may be cleaned by soaking, spraying solvents or detergent and water onto the sensor tubes, or by ultrasonic cleaning. Lime deposits may be safely removed by soaking in 20% hydrochloric acid. Warming to +150° F (+66° C) is permissible to speed this process.

For unusual cleaning problems, contact the factory and determine the exact materials of construction and chemical compatibility before using strong acids or unusual cleansers.

3.6.2 Probe Replacement

NOTE: The switch will require recalibration (section 2.6) following probe replacement.

3.6.2.1 Integral Electronics

Removal of probe

1. Make sure the power source is turned off.
2. Unscrew and remove housing cover.
3. Remove the bezel by:
 - a. TD1 – removing the fastening screws.
 - b. TD2 – put a screwdriver blade through hole in center and gently pull the handle away from the terminal strips.
4. Remove the fastening screws for the bracket. Remove bracket and attached circuit boards.
5. Loosen the screws on the terminal block to remove the four leads from the probe. Note that the TD1 uses a four position terminal block and the TD2 uses a six position terminal block.
6. Unscrew probe from enclosure.

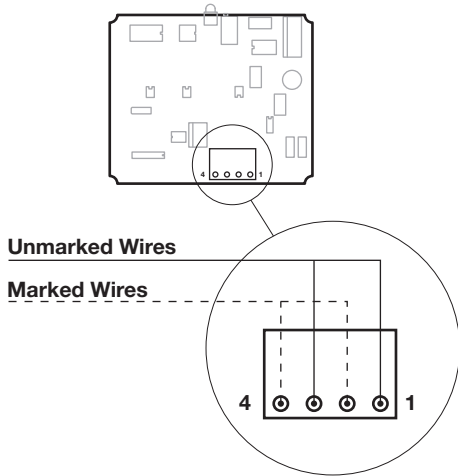

Figure 15
TD1 Probe Connections

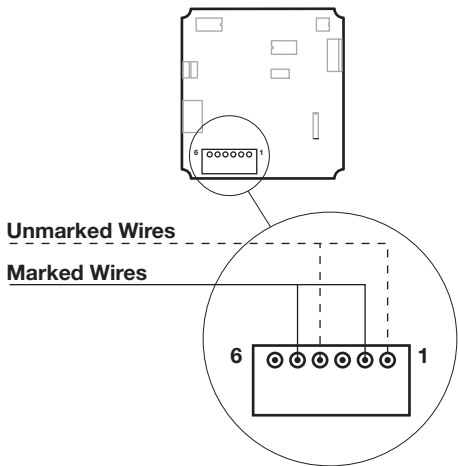

Figure 16
TD2 Probe Connections

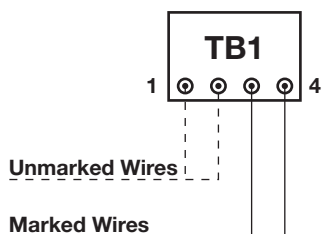

Figure 17
TD2 Remote Probe Connections

Installation of replacement probe





(Refer to Figures 15 & 16).

1. The probe's leads have been separated at the factory. One set of leads is marked with a "1," the second set is unmarked. Connect leads from RTD #1:
 - TD1 – Connect between terminals 1 and 3.
 - TD2 – Connect between terminals 2 and 5.
2. Connect the second set of leads:
 - TD1 – Connect between terminals 2 and 4.
 - TD2 – Connect between terminals 1 and 4.
3. Replace bezel and housing cover.
 - TD1 – Replace bezel and refasten screws.
 - TD2 – Reinstall bracket assembly. Ensure that the tab at the bottom of the bracket engages in the hole in the bottom of housing. Reinstall bracket mounting screws. Replace bezel by gently pressing down on the center of the bezel. Ensure that the outer edge of bezel is evenly seated in the housing.
4. Replace housing cover.
5. Apply power.
6. Recalibrate as described in Section 2.6.

3.6.2.2 Remote Electronics (TD2 only)

1. Make sure the power source is turned off.
2. Remove the cover from the sensor enclosure.
3. Loosen the screws on the four position terminal block (TB1) to remove the leads from the probe.
4. Unscrew probe from enclosure.
 - a. The probe's leads have been separated at the factory. Connect leads from RTD #1, which are grouped and marked, to pins 3 & 4 (the two terminals on TB1 closest to the sensor label) refer to Figure 17.
 - b. Connect the other pair of leads, which are not marked, to pins 1 & 2 (the remaining two positions on TB1).
5. Replace housing cover.
6. Apply power.
7. Recalibrate as described in Section 2.6.

3.7 Agency Approvals

AGENCY	MODEL APPROVED	APPROVAL CATEGORY	APPROVAL CLASSES	
FM  APPROVED	TD1-2D00-0XX TD2-XX0X-Xab a = 3, C, G b = 0, 1, 2, 3	Explosion Proof	Class I, Div 1; Groups B, C, D TD1=T6 TD2=T5 Class II & III, Div 1; Groups E, F, G Type 4X and IP66	
	TD1-2D00-0XX TD2-XX0X-XXX	Non-Incendive	Class I, Div 2; Groups A, B, C, D Class II & III, Div 2; Groups E, F, G T4 Type 4X and IP66	
	PROBE MODEL TXX-XXXX-XXX	Explosion Proof	Class I, Div 1; Groups B, C, D T4 Class II & III, Div 1; Groups E, F, G Type 4X and IP 66	
CSA  <i>These probes comply with Canadian Electrical code requirements of ANSI/ISA 12.27.01-2003 as a single seal device</i>	TD1-2D00-0XX TD2-XX0X-Xab a = 3, C, G b = 0, 1, 2, 3	Explosion Proof	Class I, Div 1; Groups B, C, D T6 Class II & III, Div 1; Groups E, F, G Type 4X and IP66	
	TD1-2D00-0XX TD2-XX0X-XXX	Suitable for	Class I, Div 2; Groups A, B, C, D Class II & III, Div 2; Groups E, F, G T4 Type 4X and IP66	
	TD1-2D00-0X0 TD2-XX0X-Xab a = 3, C, G b = 0, 1, 2, 3	Explosion Proof	Class I, Zone 1, Ex d IIC T6	
	PROBE MODEL TXX-XXX0-XXX	Explosion Proof	Class I, Div 1; Groups B, C, D T4 Class II & III, Div 1; Groups E, F, G Type 4X and IP66	
ATEX 	Zone 0 Service TXX-XDXX-XCX	EEx d Explosion Proof w/IS probe	⊕ II 1/2G EEx d+ib d{ib} IIC T5/T4 IP66	
	TXX-XHXX-XCX	EEx d Explosion Proof (requires 1 mm probe provided when fourth digit of probe model number is B, C, or D)	⊕ II 1/2G EEx d IIC T5/T4 IP66	
	Zone 1 Service TXX-XXXX-XGX	EEx d Explosion Proof	⊕ II 2G EEx d IIC T5/T4 IP66	
INMETRO 	TD1-2D00-0XX TD2-XD0X-XCX TXX-XHXX-XCX	Ex d Explosion Proof w/IS probe circuit EEx d Explosion Proof (requires 1 mm probe provided when fourth digit of probe model number is B, C, or D)	BR-Ex d[ib] IIC T5/T4 IP66 - Electronics BR-Ex d+ib IIC T5/T4 IP66 - Probe BR-Ex d IIC T5/T4 IP66	
	Zone 1 Service TXX-XXXX-XGX	EEx d Explosion Proof	BR-Ex d IIC T5/T4 IP66	
RosTEch/FSTS	TDX-XXXX-XCX TDX-XXXX-XGX	Russian Authorisation Standards <i>Consult Magnetrol for details.</i>		
CCOE	TDX-XXXX-XCX TDX-XXXX-XGX	Hazardous Approvals - India <i>Consult Magnetrol for details.</i>		

 These units have been tested to EN 61326 and are in compliance with the EMC Directive 89/336/EEC.

3.8 Replacement Parts

3.8.1 Model TD1

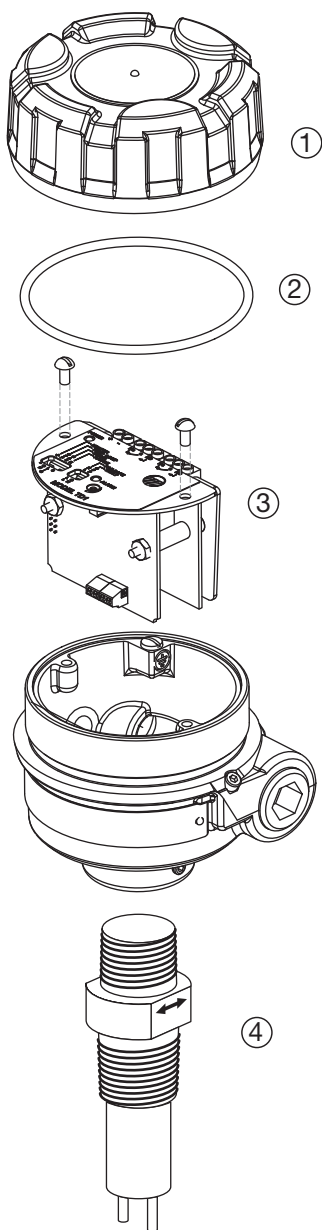

Model TD1

Item	Description	Part Number
1	Aluminum Cover	004-9193-002
2	O-ring	012-2201-237
3	Electronic module with bracket	089-7250-001
4	Probe	See Probe Model Number

3.8.2 Model TD2

Model TD2

Item	Description	Part Number
1	Aluminum Cover (without window)	004-9192-009
	Aluminum Cover (with window)	036-4410-010
2	O-Ring	012-2201-237
3	Remote Housing Cover	004-9193-002
4	Bezel	003-1230-004
5	Electronic Module	see table below
6	Probe	See Probe Model Number
7	Remote Circuit Board	030-3586-001

Electronic Module – 8 amp DPDT relay (use with TD2-XX0X-X3X and TD2-XX0X-XGX)

	Integral (8th digit = 0)	Remote (8th digit = 1)
AC (4th digit = 7)	089-7250-002	089-7250-004
DC (4th digit = 8)	089-7250-003	089-7250-005

Electronic Module – 1 amp Hermetically Sealed Relay (use with TD2-XH0X-XXX)

	Integral (8th digit = 0)	Remote (8th digit = 1)
AC (4th digit = 7)	089-7250-006	089-7250-008
DC (4th digit = 8)	089-7250-007	089-7250-009

Electronic Module – 8 amp DPDT Zone 0 Service (use with TD2-XX0X-XCX)

	Integral (8th digit = 0)	Remote (8th digit = 1)
AC (4th digit = 7)	089-7250-010	089-7250-012
DC (4th digit = 8)	089-7250-011	089-7250-013

NOTE: Contact Magnetrol for Modules for Hygienic Enclosure (digit 10 = 4 or 5).

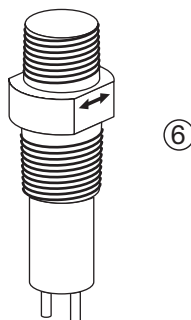
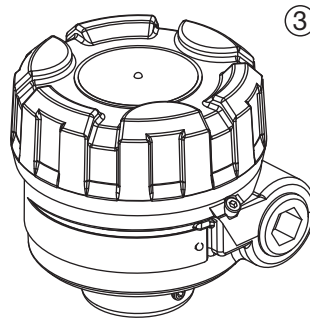
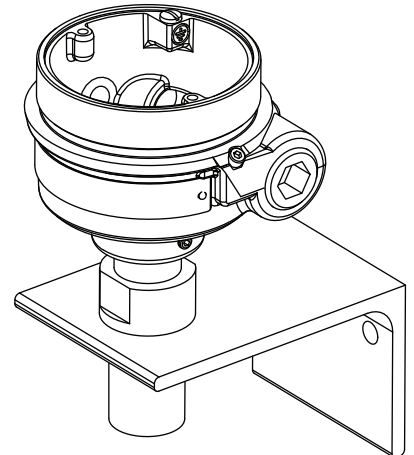
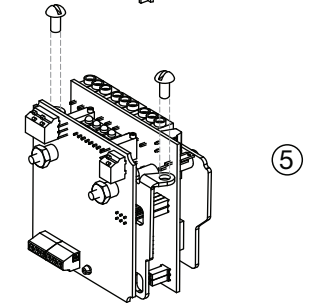
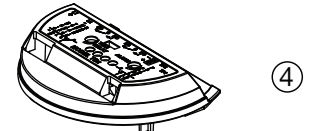
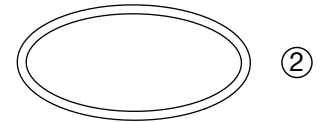
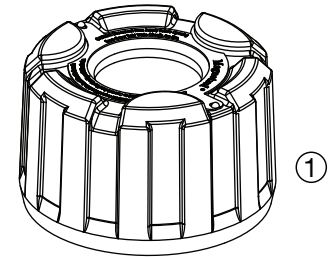

3.9 Specifications

3.9.1 Performance

Supply Voltage	TD1	19.2 to 28.8 VDC ===
	TD2	19.2 to 28.8 VDC or 100 to 264 VAC ~, 50–60 Hz
Power Consumption	TD1:	3.5 Watts at 24 VDC, 4.5 Watts at 30 VDC
	TD2:	4 Watts at 24 VDC, 4.5 Watts at 30 VDC, 5 Watts at 100 to 264 VAC
Power to Probe		Less than 1 Watt
Output Relay	TD1 Electronics:	DPDT, 8 Amp, 120 VAC, 250 VAC 8 Amp at 30 VDC, 0.5 Amp at 125 VDC
	TD2 Electronics:	DPDT, 8 Amp at 120 VAC, 250 VAC 8 Amp at 30 VDC, 0.5 Amp at 125 VDC or Hermetically Sealed DPDT 1 Amp at 28 VDC, 0.5 Amp at 125 VDC
Ambient Temperature	Electronics:	-40° to +158° F (-40° to +70° C)
Storage Temperature	Electronics:	-58° to +170° F (-50° to +76° C)
Operating Temperature	Sensor:	-100° to +400° F (-73° to +200° C) ①
High Temperature Sensor		-100° to +850° F (-73° to +454° C)
Response Time		1–10 seconds (typical – dependent upon sensor type, application, and set point adjustment)
Set Point Range	Water:	0.01 to 5.0 fps (0.003 to 1.5 m/s) (spherical tip and twin tip sensors) 0.01 to 1.0 fps (0.003 to 0.3 m/s) (HTHP, Hastelloy®, Monel sensors)
	Air:	0.1 to 500 fps (0.3 to 150 m/s)
Time Delay (TD2 only)		0–100 seconds adjustable (time delay in addition to sensor response)
Repeatability		<1% at constant temperature
Enclosure Material		Cast aluminum A356 containing less than 0.2% copper, 316 stainless steel or 304 stainless steel

① Use a probe with heat extension or remote electronics for process temperatures greater than +250° F (+120° C)

3.9.2 Probe

Probe Materials of Construction	Twin Tip	All wetted parts of 316/316L stainless steel, Hastelloy C, or Monel
	Mini Sensor	316/316L stainless steel
	Spherical Tip	316/316L stainless steel
	Low Flow Body	316/316L stainless steel
Process Connection		Refer to part number construction
TXA, TXB, TXC, TXD Probe Insertion Length		2" (5 cm) minimum. Available in lengths from 2 to 130" in 1" increments ② (5 to 330 cm in 1 cm increments)
TEM, TMM sensor		1" (2.5 cm) minimum. Available insertion lengths 1" to 60" (5 to 152 cm)
TEH, TMH Sensor		2" (5 cm) minimum Available in lengths from 2 to 36" in 1" increments ② (5 to 91 cm in 1 cm increments)
TEL, TML, Low Flow Body		¼" and ½" NPT and G (BSP) threads.
Cable Length		500 feet (150 meters) maximum
Shipping Weight		4.6 lbs. (with 2" probe)

② Longer lengths available. Consult factory.

Pressure/Temperature Rating (DEPENDENT ON PROCESS CONNECTION)

Probe Style	Insertion Length	Pressure/Temperature Rating		
		+100° F (+38° C)	+400° F (+204° C)	+850° F (+454° C)
Twin Tip (TXC, TXD) (stainless steel)	2" (5 cm)	3000 psig (206 bar)	2280 psig (157 bar)	—
	3–130" (7–330 cm)	1850 psig (127 bar)	1680 psig (115 bar)	—
Twin Tip (TXC, TXD) (Hastelloy C)	2" (5 cm)	3000 psig (206 bar)	2340 psig (161 bar)	—
	3–130" (7–330 cm)	1500 psig (103 bar)	1170 psig (80 bar)	—
Twin Tip (TXC, TXD) (Monel)	2" (5 cm)	2500 psig (172 bar)	1980 psig (136 bar)	—
	3–130" (7–330 cm)	1200 psig (82 bar)	950 psig (65 bar)	—
Spherical (TXA, TXB)	2–130" (5–330 cm)	600 psig (41 bar)	415 psig (28 bar)	—
Mini Sensor (TXM)	1" (2.5 cm)	3000 psig (206 bar)	2280 psig (157 bar)	—
	2–130" (5–330 cm)	1850 psig (127 bar)	1680 psig (115 bar)	—
Low flow body (TEL)	—	5800 psig (400 bar)	4100 psig (285 bar)	—
High temperature (TXH)	2–36" (5–90 cm)	6000 psig (413 bar)	4280 psig (295 bar)	3380 psig (233 bar)

3.9.3 Physical – inches (mm)

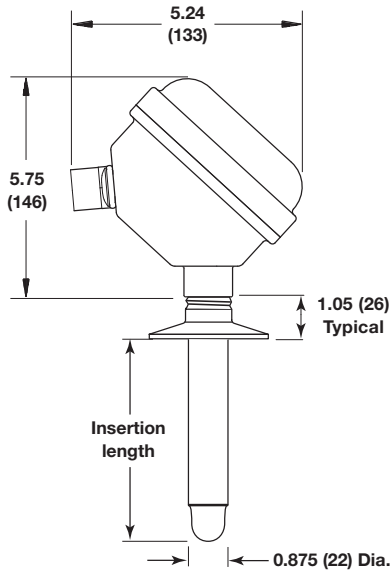

**Model TD2
with Hygienic Housing
16-Amp Fitting**

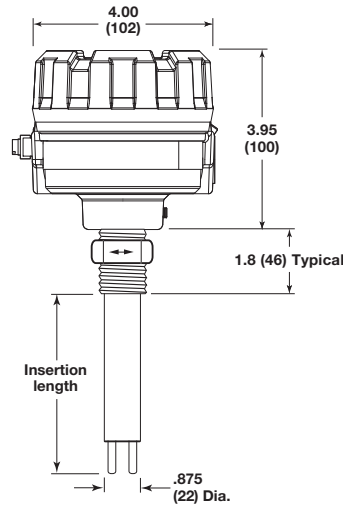

**Model TD1
with Twin Tip Probe**

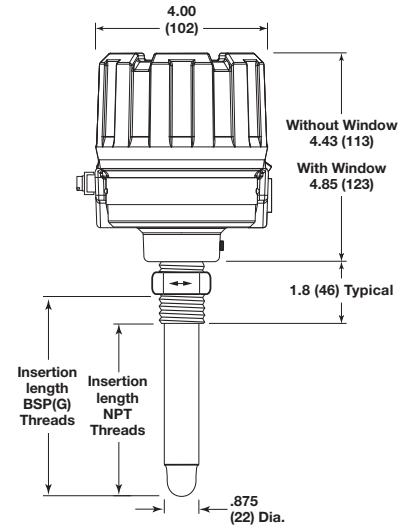

**Model TD2 Integral Electronics
with Spherical Tip Probe**

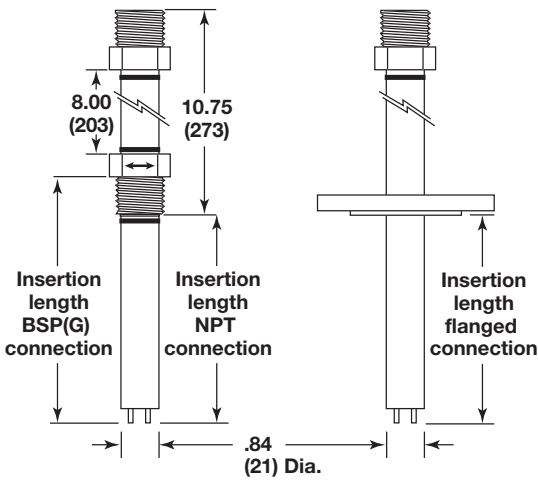

**High Temp/Pressure Sensor
(TXH)**

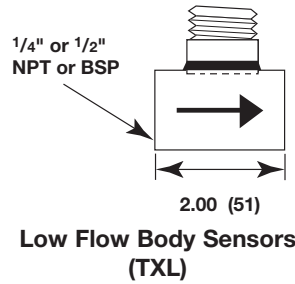

**Low Flow Body Sensors
(TXL)**

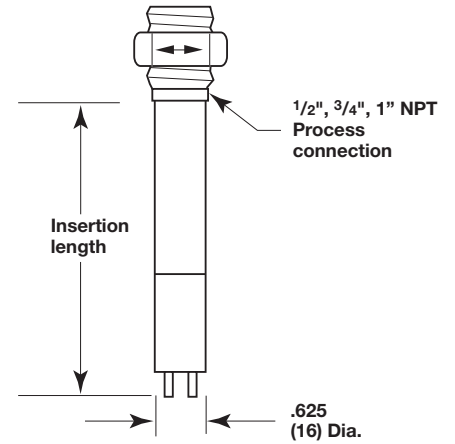

**Mini Sensor
(TXM)**

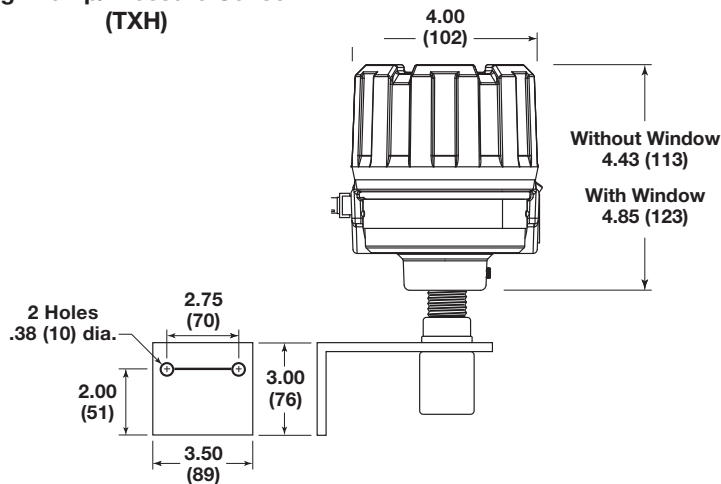

**Model TD2
with Remote Electronics**

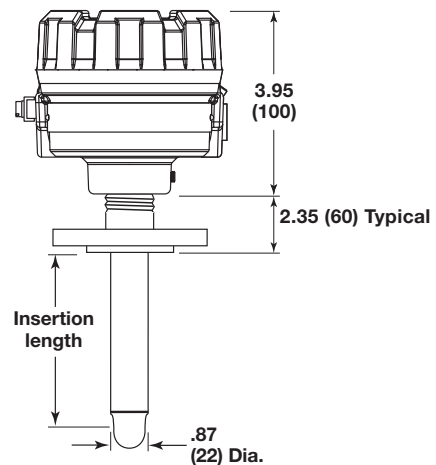

**Remote Spherical Tip Probe
with Flange Connection**

3.10 Model Numbers

3.10.1 Model TD1

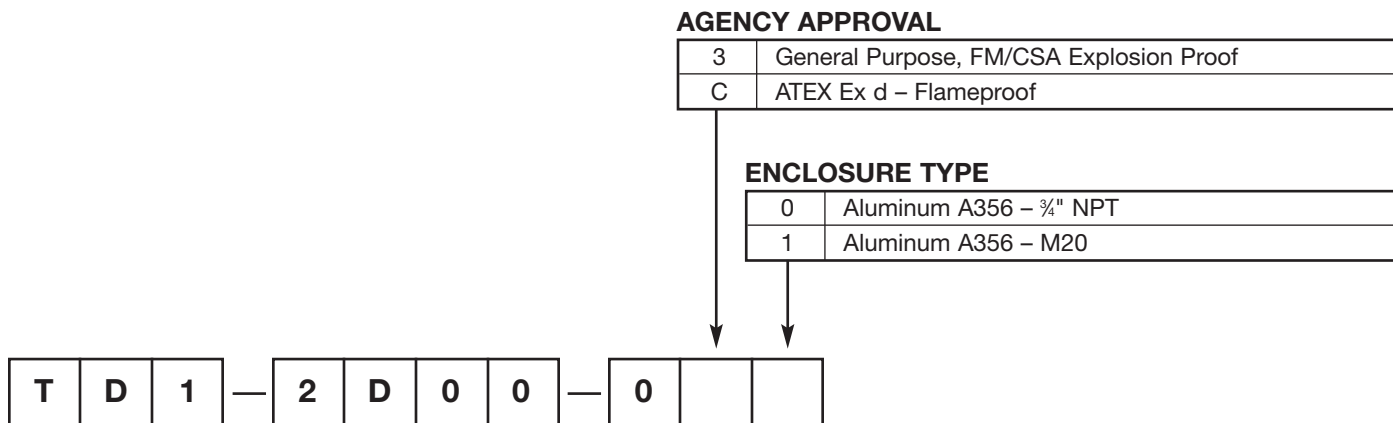

3.10.2 Model TD2

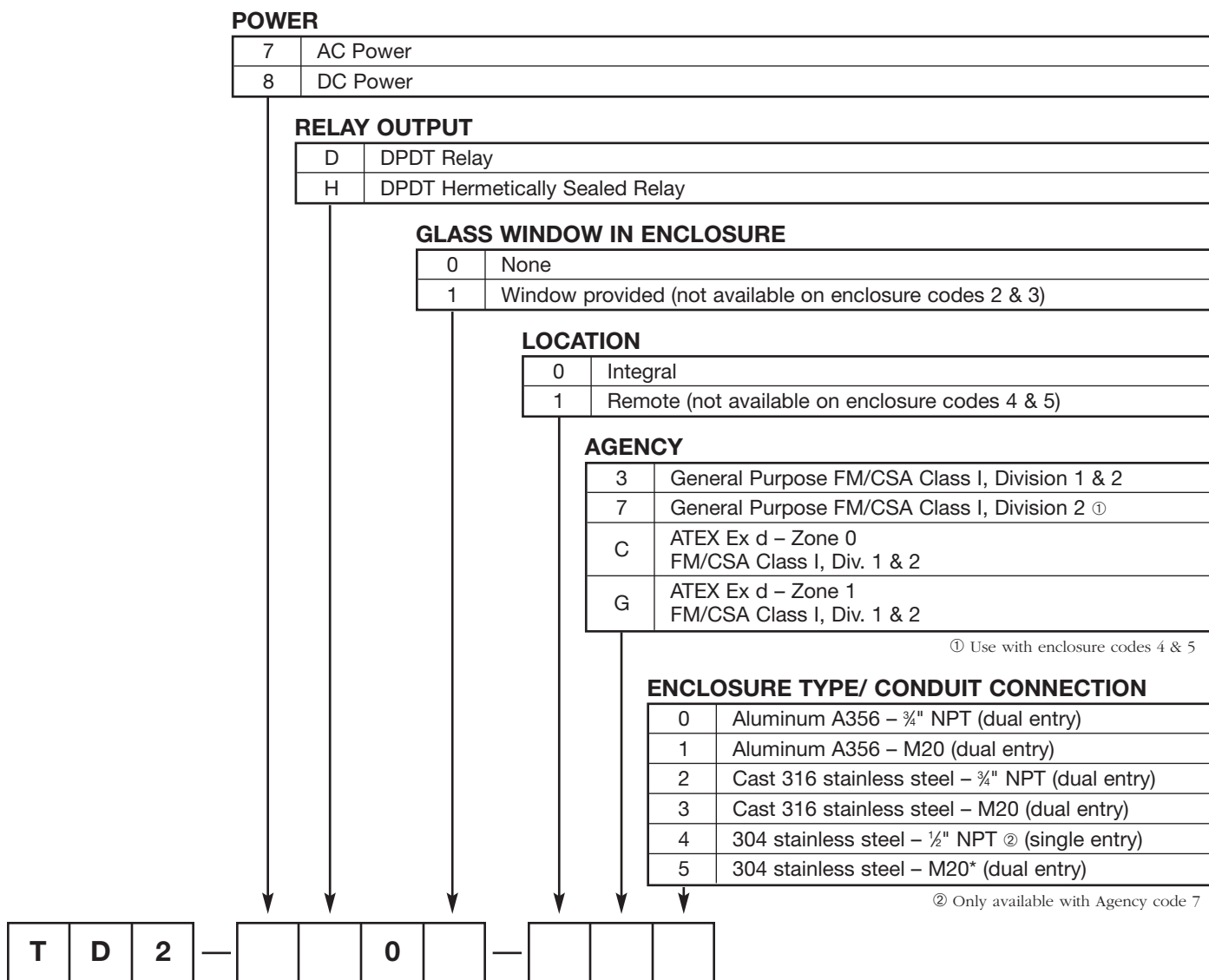

3.10.3 Standard Probe

MODEL

TE	Probe length in inches
TM	Probe length in centimeters

TIP STYLE

A	Spherical tip ①	max. +250° F (+121° C)/max. 600 psi (41 bar)
B	Spherical tip – with 6" (15 cm) heat extension ①	max. +400° F (+204° C)/max. 600 psi (41 bar)
C	Twin tip	max. +250° F (+121° C)/max. 3000 psi (207 bar) ②
D	Twin tip – with 6" (15 cm) heat extension	max. +400° F (+204° C)/max. 3000 psi (207 bar) ②

① Available only with stainless steel construction

② Consult pressure/temperature chart on page 25 for pressure rating on extended length probe.

MATERIAL OF CONSTRUCTION

A	316/316L stainless steel
B	Hastelloy® C
C	Monel®
D	316/316L stainless steel with 1 mm probe thickness ③

③ Available only with TMX probes

PROCESS CONNECTION SIZE/TYPE

11	¾" NPT Thread
21	1" NPT Thread
22	G1 (1" BSP) Thread

ANSI RAISED FACE FLANGE CONNECTIONS

23	1"	150#	ANSI RF Flange	35	1½"	600#	ANSI RF Flange
24	1"	300#	ANSI RF Flange	43	2"	150#	ANSI RF Flange
25	1"	600#	ANSI RF Flange	44	2"	300#	ANSI RF Flange
33	1½"	150#	ANSI RF Flange	45	2"	600#	ANSI RF Flange
34	1½"	300#	ANSI RF Flange				

EN/DIN FLANGED CONNECTIONS ④

BA	DN 25	PN 16	EN 1092-1 Type A	CC	DN 40	PN 64/100	EN 1092-1 Type B2
BB	DN 25	PN 25/40	EN 1092-1 Type A	DA	DN 50	PN 16	EN 1092-1 Type A
BC	DN 25	PN 64/100	EN 1092-1 Type B2	DB	DN 50	PN 25/40	EN 1092-1 Type A
CA	DN 40	PN 16	EN 1092-1 Type A	DD	DN 50	PN 64	EN 1092-1 Type B2
CB	DN 40	PN 25/40	EN 1092-1 Type A	DE	DN 50	PN 100	EN 1092-1 Type B2

④ DIN flanges only available in metric length (TMX) probes.

HYGIENIC FLANGE CONNECTIONS

3T	1" and 1½"	3A compatible	Tri-Clamp® ⑤
4T	2"	3A compatible	Tri-Clamp® ⑤
VV	DN65	Varivent® ⑥	

⑤ Only available for Spherical Sensor (TMA/TMB) Contact Magnetrol for other hygienic fittings including Neumo, G1A, and DIN 11.851.

⑥ Only available for TXA TipStyle.

INSERTION LENGTH

2" to 130" in 1" increments ⑦
 Example: 4 inches = code 004
 Note: minimum 3" with flanges and G1 (BSP) threads

005	Minimum length 50 mm with NPT threads
008	Minimum length 80 mm with G1 (BSP) and flange connections
Extended lengths in 10 mm increments to length 3300 mm ⑦	
Examples: 50 mm = code 005, 3300 mm = code 330	

⑦ Longer lengths available — consult factory

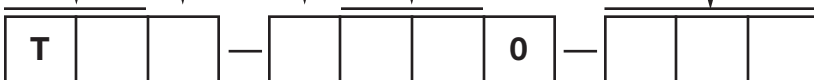

3.10.4 High Temperature Probe

MODEL

TE	Probe length in inches
TM	Probe length in centimeters

TIP STYLE

H	High temperature/high pressure twin tip	max. +850° F (+450° C)/max. 6000 psi (413 bar)
---	---	--

MATERIAL OF CONSTRUCTION

A	316/316L stainless steel
B	Hastelloy® C
D	316/316L stainless steel with 1 mm probe thickness ①

① Available only with TMX probes

PROCESS CONNECTION SIZE/TYPE

11	3/4" NPT Thread
21	1" NPT Thread
22	G1 (1" BSP) Thread

ANSI RAISED FACE FLANGE CONNECTIONS

23	1"	150#	ANSI RF Flange	37	1 1/2"	900/1500#	ANSI RF Flange
24	1"	300#	ANSI RF Flange	38	1 1/2"	2500#	ANSI RF Flange
25	1"	600#	ANSI RF Flange	43	2"	150#	ANSI RF Flange
27	1"	900/1500#	ANSI RF Flange	44	2"	300#	ANSI RF Flange
33	1 1/2"	150#	ANSI RF Flange	45	2"	600#	ANSI RF Flange
34	1 1/2"	300#	ANSI RF Flange	47	2"	900/1500#	ANSI RF Flange
35	1 1/2"	600#	ANSI RF Flange	48	2"	2500#	ANSI RF Flange

EN/DIN FLANGED CONNECTIONS ②

BA	DN 25	PN 16	EN 1092-1 Type A	DA	DN 50	PN 16	EN 1092-1 Type A
BB	DN 25	PN 25/40	EN 1092-1 Type A	DB	DN 50	PN 25/40	EN 1092-1 Type A
BC	DN 25	PN 64/100	EN 1092-1 Type B2	DD	DN 50	PN 64	EN 1092-1 Type B2
BG	DN 25	PN 250	DIN 2527, Form E	DE	DN 50	PN 100	EN 1092-1 Type B2
CA	DN 40	PN 16	EN 1092-1 Type A	DG	DN 50	PN 250	DIN 2527, Form E
CB	DN 40	PN 25/40	EN 1092-1 Type A	DJ	DN 50	PN 400	DIN 2527, Form E
CC	DN 40	PN 64/100	EN 1092-1 Type B2				
CG	DN 40	PN 250	DIN 2527, Form E				
CJ	DN 40	PN 400	DIN 2527, Form E				

② DIN flanges only available on metric length (TMH) probes.

INSERTION LENGTH

2" to 36" in 1" increments ③
 Example: 6 inch probe = 006
 Note: minimum 3" with Flanges and G1 (BSP) threads

005	Minimum length 50 mm with NPT Threads
007	Minimum length 70 mm with G1 (BSP) or flange connections
Extended lengths in 10 mm increments to 910 mm ③	
Examples: 50 mm = code 005, 910 mm = code 091	

③ Longer lengths available — consult factory



3.10.5 Low Flow Body

MODEL

TEL	Low Flow Body
-----	---------------

MATERIAL OF CONSTRUCTION

A	316/316L stainless steel
---	--------------------------

PROCESS CONNECTION SIZE/TYPE

T1	¼" NPT Thread
V1	½" NPT Thread
T0	G ¼ (¼" BSP) Thread
V0	G ½ (½" BSP) Thread

MOUNTING BRACKET

000	None
100	With mounting bracket

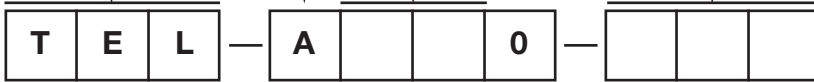

3.10.6 Mini Sensor

MODEL

TE	Probe length in inches
TM	Probe length in centimeters

BODY STYLE

M	Mini twin tip	max. +400° F (+204° C)/max. 3000 psi (207 bar) for standard sensor length max. +400° F (+204° C)/max. 1850 psi (127 bar) for sensors ≥ 2" (50 mm)
---	---------------	--

MATERIAL OF CONSTRUCTION

A	316/316L stainless steel
---	--------------------------

PROCESS CONNECTION SIZE/TYPE

01	½" NPT Thread
11	¾" NPT Thread
21	1" NPT Thread

INSERTION LENGTH

1" to 130" in 1" increments Example: 6 inch probe = code 006

50 mm to 3300 mm in 10 mm increments Examples: 50 mm = code 005, 3300 mm = code 330 Note: Use code 003 for minimum length of 25 mm
--



3.10.7 Connecting Cable (General Purpose, FM/CSA)

CONNECTING CABLE IN FEET

Cable length in feet; 10 feet minimum to 500 feet maximum length
Example: 12 feet = code 012

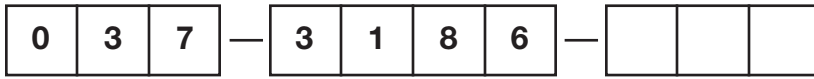

CONNECTING CABLE IN METERS

3 meters minimum to 152 meters maximum length
Example: 3 meters = code 003

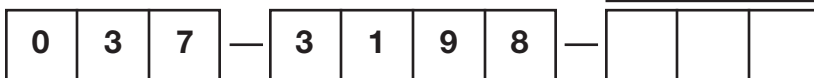

Service Policy

Owners of Magnetrol may request the return of a control or any part of a control for complete rebuilding or replacement. They will be rebuilt or replaced promptly. Controls returned under our service policy must be returned by Prepaid transportation. Magnetrol will repair or replace the control at no cost to the purchaser (or owner) other than transportation if:

1. Returned within the warranty period; and
2. The factory inspection finds the cause of the claim to be covered under the warranty.

If the trouble is the result of conditions beyond our control; or, is NOT covered by the warranty, there will be charges for labor and the parts required to rebuild or replace the equipment.

In some cases it may be expedient to ship replacement parts; or, in extreme cases a complete new control, to replace the original equipment before it is returned. If this is desired, notify the factory of both the model and serial numbers of the control to be replaced. In such cases, credit for the materials returned will be determined on the basis of the applicability of our warranty.

No claims for misapplication, labor, direct or consequential damage will be allowed.

Return Material Procedure

So that we may efficiently process any materials that are returned, it is essential that a "Return Material Authorization" (RMA) number be obtained from the factory, prior to the material's return. This is available through Magnetrol's local representative or by contacting the factory. Please supply the following information:

1. Company Name
2. Description of Material
3. Serial Number
4. Reason for Return
5. Application

Any unit that was used in a process must be properly cleaned in accordance with OSHA standards, before it is returned to the factory.

A Material Safety Data Sheet (MSDS) must accompany material that was used in any media.

All shipments returned to the factory must be by prepaid transportation.

All replacements will be shipped F.O.B. factory.

NOTE: See Electrostatic Discharge Handling Procedure on page 4.



5300 Belmont Road • Downers Grove, Illinois 60515-4499 • 630-969-4000 • Fax 630-969-9489 • www.magnetrol.com
 145 Jardin Drive, Units 1 & 2 • Concord, Ontario Canada L4K 1X7 • 905-738-9600 • Fax 905-738-1306
 Heikensstraat 6 • B 9240 Zele, Belgium • 052 45.11.11 • Fax 052 45.09.93
 Regent Business Ctr., Jubilee Rd. • Burgess Hill, Sussex RH15 9TL U.K. • 01444-871313 • Fax 01444-871317

Copyright © 2010 Magnetrol International, Incorporated. All rights reserved. Printed in the USA.

CSA logotype is a registered trademark of Canadian Standards Association
 Hastelloy® and C22® are registered trademarks of Haynes International, Inc.
 Monel® is a registered trademark of Special Metals Corporation (Formerly Inco Alloys International)
 Varivent® is a registered trademark of Tuchenhagen GmbH LTD

BULLETIN: 54-610.7
EFFECTIVE: November 2010
SUPERSEDES: April 2010