



SB160

Preliminary

DIODE

1.0A SCHOTTKY BARRIER RECTIFIER

DESCRIPTION

The UTC **SB160** is a Schottky Rectifier with high current capacity and low forward voltage.

The UTC **SB160** is suitable for polarity protection ,low voltage and high frequency inverters and free wheeling applications

FEATURES

- * High Current Capability
- * Low Forward Voltage

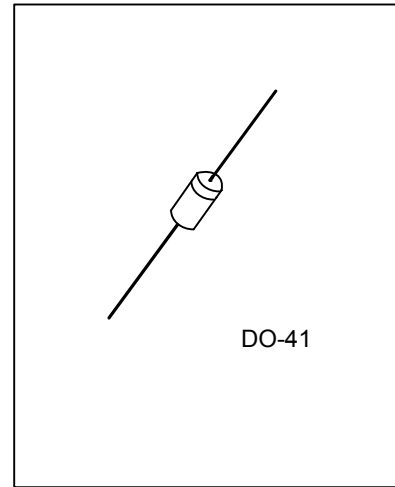

ORDERING INFORMATION

Ordering Number		Package	Pin Assignment		Packing
Lead Free	Halogen Free		1	2	
SB160L-Z41-R	SB160G-Z41-R	DO-41	K	A	Tape Reel

Note: Pin Assignment: A: Anode, K: Cathode

<p>SB160L-Z41-R</p> <p>(1)Packing Type (2)Package Type (3)Lead Free</p>	<p>(1) R: Tape Reel (2) Z41: DO-41 (3) Halogen Free, L: Lead Free</p>
---	---

■ ABSOLUTE MAXIMUM RATINGS ($T_A=25^{\circ}\text{C}$ unless otherwise specified.)

PARAMETER	SYMBOL	RATINGS	UNIT
Peak Repetitive Reverse Voltage	V_{RRM}	60	V
Working Peak Reverse Voltage	V_{RWM}	60	V
DC Blocking Voltage	V_R	60	V
RMS Reverse Voltage	$V_{R(RMS)}$	42	V
Forward Voltage ($I_F=1.0A$) (Note 3)	V_{FM}	0.7	V
Non-Repetitive Peak Forward Surge Current 8.3ms single half sine-wave superimposed on rated load (JEDEC Method)	I_{FSM}	40	A
Average Rectified Output Current (Note 2)	I_O	1.0	A
Peak Reverse Current at Rated DC Blocking Voltage (Note 3)	$T_A=25^{\circ}\text{C}$	0.5	mA
	$T_A=100^{\circ}\text{C}$	5.0	mA
Operating Temperature	T_J	-65~+150	$^{\circ}\text{C}$
Storage Temperature	T_{STG}	-65~+150	$^{\circ}\text{C}$

Note: 1. Absolute maximum ratings are those values beyond which the device could be permanently damaged.

Absolute maximum ratings are stress ratings only and functional device operation is not implied.

2. Measured at ambient temperature at a distance of 9.5mm from the case.
3. Short duration test pulse used to minimize self-heating effect.

■ THERMAL DATA

PARAMETER	SYMBOL	RATINGS	UNIT
Junction to Ambient	θ_{JA}	50	$^{\circ}\text{C}/\text{W}$

UTC assumes no responsibility for equipment failures that result from using products at values that exceed, even momentarily, rated values (such as maximum ratings, operating condition ranges, or other parameters) listed in products specifications of any and all UTC products described or contained herein. UTC products are not designed for use in life support appliances, devices or systems where malfunction of these products can be reasonably expected to result in personal injury. Reproduction in whole or in part is prohibited without the prior written consent of the copyright owner. The information presented in this document does not form part of any quotation or contract, is believed to be accurate and reliable and may be changed without notice.