

GPN2222A NPN EPITAXIAL PLANAR TRANSISTOR

Description

The GPN2222A is designed for general purpose amplifier and high speed, medium-power switching applications.

Features

- *Low Collector Saturation Voltage
- *High Speed Switching
- *For Complementary Use with PNP Type GPN2907A

Package Dimensions

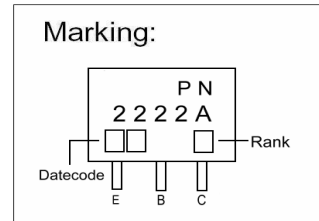
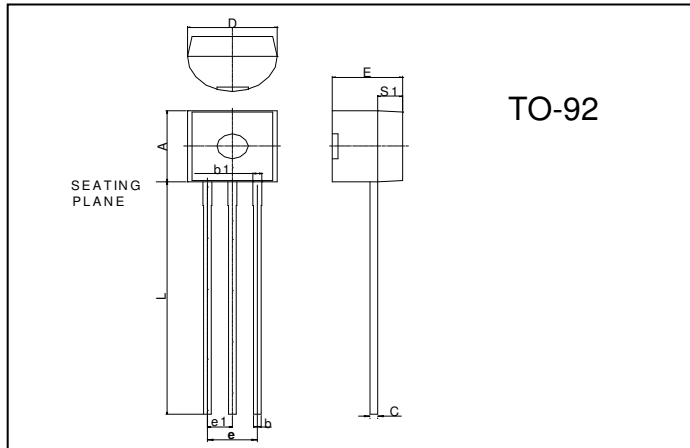

REF.	Millimeter		REF.	Millimeter	
	Min.	Max.		Min.	Max.
A	4.45	4.7	D	4.44	4.7
S1	1.02	-	E	3.30	3.81
b	0.36	0.51	L	12.70	-
b1	0.36	0.76	e1	1.150	1.390
C	0.36	0.51	e	2.42	2.66

Absolute Maximum Ratings at Ta = 25°C

Parameter	Symbol	Ratings	Unit
Junction Temperature	Tj	+150	°C
Storage Temperature	Tstg	-55 ~ +150	°C
Collector to Base Voltage	VCBO	75	V
Collector to Emitter Voltage	VCEO	40	V
Emitter to Base Voltage	VEBO	6	V
Collector Current	Ic	600	mA
Total Power Dissipation	PD	625	mW

Characteristics at Ta = 25°C

Symbol	Min.	Typ.	Max.	Unit	Test Conditions
BVCBO	75	-	-	V	Ic=10uA, IE=0
BVCEO	40	-	-	V	Ic=10mA, IB=0
BVEBO	6	-	-	V	IE=10uA, Ic=0
ICBO	-	-	10	nA	VCE=60V, IE = 0
ICEX	-	-	10	nA	VCE=60V, VBE(OFF)=3V
IEBO	-	-	50	nA	VEB=3V, Ic = 0
*VCE(sat)1	-	-	0.3	V	Ic=150mA, IB=15mA
*VCE(sat)2	-	-	1.0	V	Ic=500mA, IB=50mA
*VBE(sat)1	-	-	1.2	V	Ic=150mA, IB=15mA
*VBE(sat)2	-	-	2	V	Ic=500mA, IB=50mA
*hFE1	35	-	-		VCE=10V, Ic=100uA
*hFE2	50	-	-		VCE=10V, Ic=1mA
*hFE3	75	-	-		VCE=10V, Ic=10mA
*hFE4	100	-	300		VCE=10V, Ic=150mA
*hFE5	40	-	-		VCE=10V, Ic=500mA
*hFE6	50	-	-		VCE=1V, Ic=150mA
fT	300	-	-	MHz	VCE=20V, Ic=20mA, f=100MHz
Cob	-	-	8	pF	VCB=10V, IE = 0, f=1MHz

* Pulse Test: Pulse Width ≤ 380us, Duty Cycle ≤ 2%

Characteristics Curve

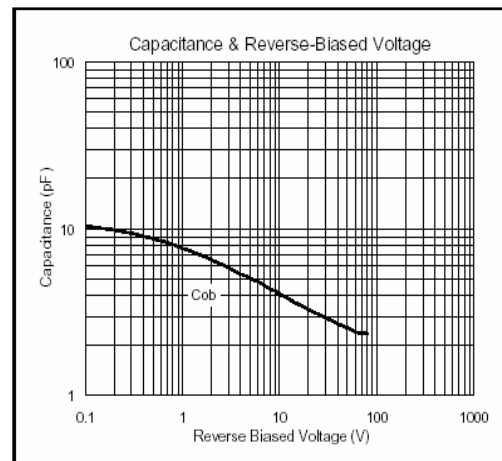
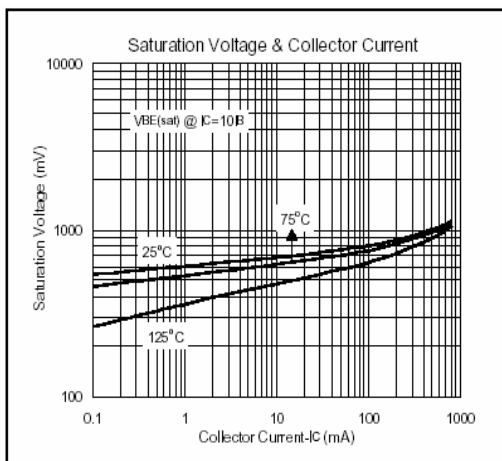
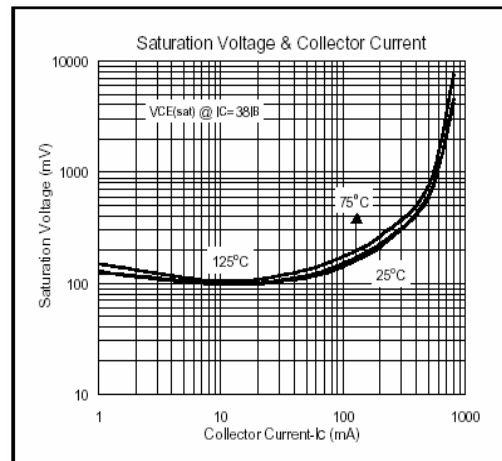
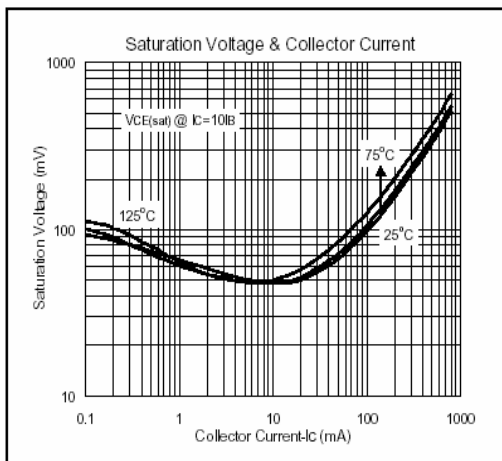
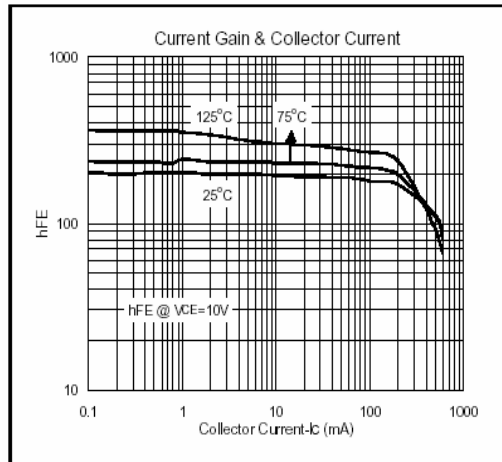
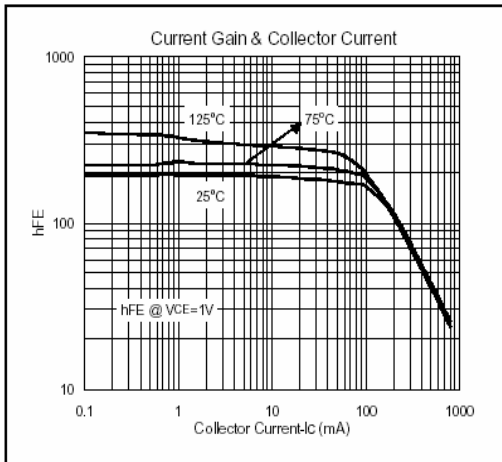

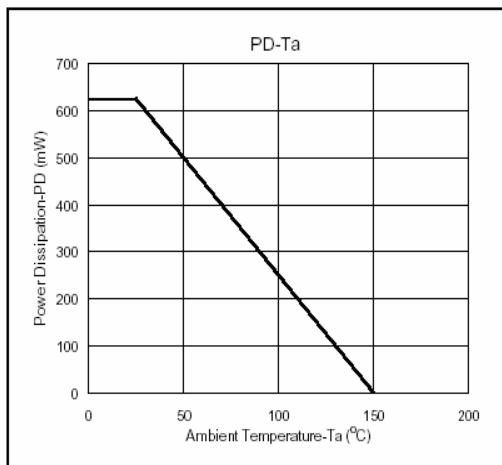
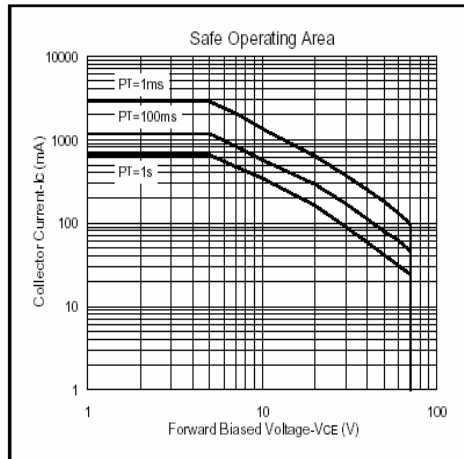
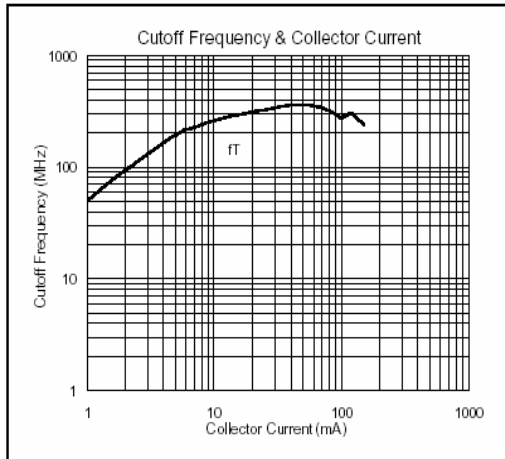

Important Notice:

- All rights are reserved. Reproduction in whole or in part is prohibited without the prior written approval of GTM.
- GTM reserves the right to make changes to its products without notice.
- GTM semiconductor products are not warranted to be suitable for use in life-support Applications, or systems.
- GTM assumes no liability for any consequence of customer product design, infringement of patents, or application assistance.

Head Office And Factory:

- **Taiwan:** No. 17-1 Tatung Rd. Fu Kou Hsin-Chu Industrial Park, Hsin-Chu, Taiwan, R. O. C.
 TEL : 886-3-597-7061 FAX : 886-3-597-9220, 597-0785
- **China:** (201203) No.255, Jang-Jiang Tsai-Lueng RD. , Pu-Dung-Hsin District, Shang-Hai City, China
 TEL : 86-21-5895-7671 ~ 4 FAX : 86-21-38950165