



20N60

Power MOSFET

20A, 600V N-CHANNEL POWER MOSFET

■ DESCRIPTION

The UTC **20N60** is an N-channel enhancement mode power MOSFET using UTC's advanced technology to provide customers with planar stripe and DMOS technology. This technology is specialized in allowing a minimum on-state resistance and superior switching performance. It also can withstand high energy pulse in the avalanche and commutation mode.

The UTC **20N60** is universally applied in motor control, UPS, DC choppers and switch-mode and resonant-mode power supplies.

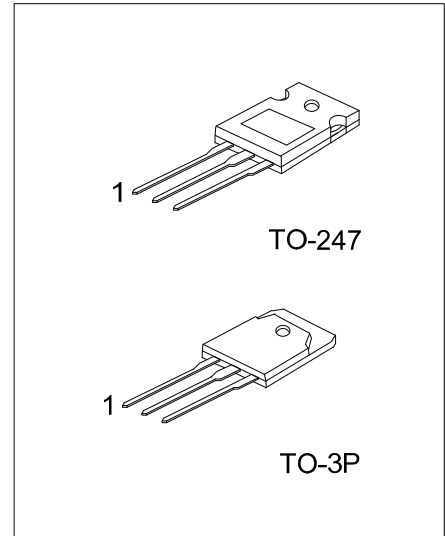

■ FEATURES

* $R_{DS(ON)} = 0.45\Omega @ V_{GS} = 10V$

* High switching speed

■ SYMBOL

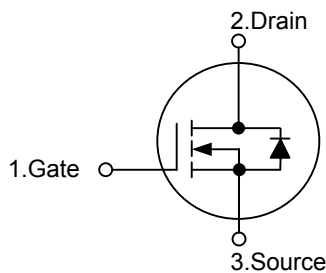

■ ORDERING INFORMATION

Ordering Number		Package	Pin Assignment			Packing
Lead Free	Halogen Free		1	2	3	
20N60L-T3P-T	20N60G-T3P-T	TO-3P	G	D	S	Tube
20N60L-T47-T	20N60G-T47-T	TO-247	G	D	S	Tube

Note: Pin Assignment: G: Gate D: Drain S: Source

<p>20N60L-T3P-T</p> <p>(1)Packing Type</p> <p>(2)Package Type</p> <p>(3)Lead Free</p>	<p>(1) T: Tube</p> <p>(2) T3P: TO-3P, T47: TO-247</p> <p>(3) G: Halogen Free, L: Lead Free</p>
---	--

■ ABSOLUTE MAXIMUM RATINGS ($T_C = 25^\circ\text{C}$, unless otherwise specified)

PARAMETER		SYMBOL	RATINGS	UNIT
Drain-Source Voltage		V_{DSS}	600	V
Gate-Source Voltage		V_{GSS}	± 20	V
Drain Current	Continuous	I_D	20	A
	Pulsed	I_{DM}	80	A
Avalanche Energy	Single Pulsed(Note 2)	E_{AS}	1200	mJ
Power Dissipation	TO-3P	P_D	300	W
	TO-247		370	
Junction Temperature		T_J	+150	$^\circ\text{C}$
Storage Temperature		T_{STG}	-55~+150	$^\circ\text{C}$

Note: 1. Absolute maximum ratings are those values beyond which the device could be permanently damaged.

Absolute maximum ratings are stress ratings only and functional device operation is not implied.

2. $V_{DD}=50\text{V}$, Starting $T_J=25^\circ\text{C}$, Peak $I_{AS}=20\text{A}$, $L=6\text{mH}$

■ THERMAL DATA

PARAMETER		SYMBOL	RATINGS	UNIT
Junction to Case	TO-3P	θ_{JC}	0.42	$^\circ\text{C}/\text{W}$
	TO-247		0.34	

■ ELECTRICAL CHARACTERISTICS ($T_J=25^\circ\text{C}$, unless otherwise specified)

PARAMETER	SYMBOL	TEST CONDITIONS	MIN	TYP	MAX	UNIT
OFF CHARACTERISTICS						
Drain-Source Breakdown Voltage	BV_{DSS}	$I_D=250\mu\text{A}$, $V_{GS}=0\text{V}$	600			V
Drain-Source Leakage Current	I_{DSS}	$V_{DS}=600\text{V}$, $V_{GS}=0\text{V}$			10	μA
Gate- Source Leakage Current	Forward	I_{GSS}			+100	nA
	Reverse				-100	nA
ON CHARACTERISTICS						
Gate Threshold Voltage	$V_{GS(TH)}$	$V_{DS}=V_{GS}$, $I_D=250\mu\text{A}$	2		4.0	V
Static Drain-Source On-State Resistance	$R_{DS(ON)}$	$V_{GS}=10\text{V}$, $I_D=10\text{A}$, Pulse test, $t \leq 300\mu\text{s}$, duty cycle $d \leq 2\%$		0.32	0.45	Ω
DYNAMIC PARAMETERS						
Input Capacitance	C_{ISS}	$V_{GS}=0\text{V}$, $V_{DS}=25\text{V}$, $f=1\text{MHz}$		4500		pF
Output Capacitance	C_{OSS}			420		pF
Reverse Transfer Capacitance	C_{RSS}			140		pF
SWITCHING PARAMETERS						
Total Gate Charge	Q_G	$V_{GS}=10\text{V}$, $V_{DS}=300\text{V}$, $I_D=10\text{A}$ (Note 1, 2)		150	170	nC
Gate to Source Charge	Q_{GS}			29	40	nC
Gate to Drain Charge	Q_{GD}			60	85	nC
Turn-ON Delay Time	$t_{D(ON)}$	$V_{GS}=10\text{V}$, $V_{DS}=300\text{V}$, $I_D=10\text{A}$, $R_G=2\Omega$, (Note 1, 2)		20	40	ns
Rise Time	t_R			43	60	ns
Turn-OFF Delay Time	$t_{D(OFF)}$			70	90	ns
Fall-Time	t_F			40	60	ns
SOURCE- DRAIN DIODE RATINGS AND CHARACTERISTICS						
Maximum Body-Diode Continuous Current	I_S	$V_{GS}=0\text{V}$			20	A
Maximum Body-Diode Pulsed Current	I_{SM}	Repetitive			80	A
Drain-Source Diode Forward Voltage	V_{SD}	$I_F=I_S$, $V_{GS}=0\text{V}$, Pulse test, $t \leq 300\mu\text{s}$, duty cycle $d \leq 2\%$			1.5	V
Body Diode Reverse Recovery Time	t_{rr}	$I_F=I_S$, $V_R=100\text{V}$, $-di/dt=100\text{A}/\mu\text{s}$ (Note 1)		600		ns

Notes: 1. Pulse Test: Pulse width $\leq 300\mu\text{s}$, Duty cycle $\leq 2\%$

2. Essentially independent of operating temperature

TYPICAL CHARACTERISTICS

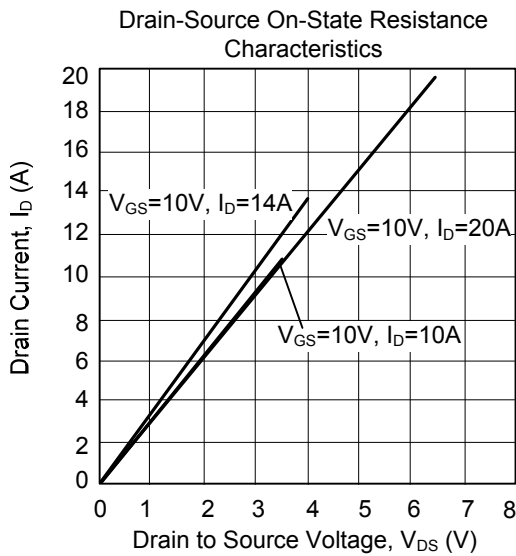
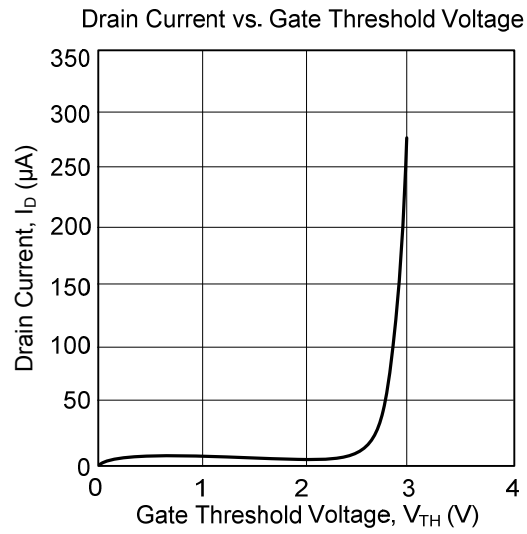
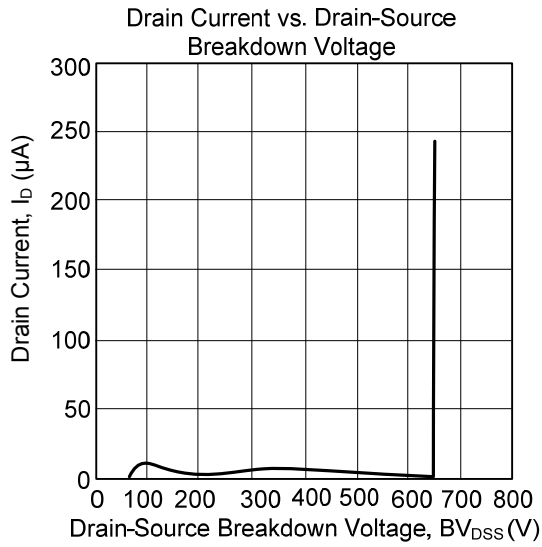

UTC assumes no responsibility for equipment failures that result from using products at values that exceed, even momentarily, rated values (such as maximum ratings, operating condition ranges, or other parameters) listed in products specifications of any and all UTC products described or contained herein. UTC products are not designed for use in life support appliances, devices or systems where malfunction of these products can be reasonably expected to result in personal injury. Reproduction in whole or in part is prohibited without the prior written consent of the copyright owner. The information presented in this document does not form part of any quotation or contract, is believed to be accurate and reliable and may be changed without notice.