

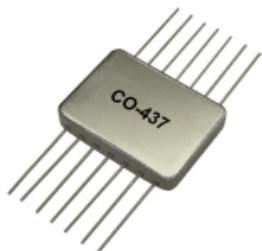

Helping Customers Innovate, Improve & Grow

Search [XOs > CO-437/457](#)**CO-437/457 ECL/PECL Clock Oscillators****Features:**

- Frequencies from 5 MHz to 700 MHz
- Low profile 14 Pin Flatpack
- 10K, 10KH, 100K, ECLinPS, 10E/EL and 100E/EL Logic

SPECIFICATIONS		
Part	CO-437	CO-457
Series	14 Pin Flatpack	
Frequency	5 MHz-700 MHz	
Output	Output taken directly from 10K, 10KH, ECLinPS or ECLinPS Lite gate, depending on temperature and frequency range. Complementary outputs optional.	Output taken directly from 100K, ECLinPS or ECLinPS Lite gate, depending on temperature and frequency range. Complementary outputs optional.
Supply	-5.2 Vdc \pm 5% <45 mA to 110 MHz <70 mA above 110 MHz	-4.5 Vdc \pm 5% at <60 mA
Accuracy (at 25°C)	CO-437E: \pm 1 ppm E = set to \pm 1 ppm via external capacitor (\leq MHz in CO-432 and \leq 240MHz in CO-434/37 package)	CO-457E: \pm 1 ppm
Temperature Stability	STANDARD: 0°C to +70°C: \pm 25 ppm Option 1: -55°C to +85°C: \pm 50 ppm Option 2: -55°C to +125°C: \pm 50 ppm Option 5: 0°C to +50°C: \pm 5 ppm Option 6: 0°C to +50°C: \pm 10 ppm Option 7: -55°C to +125°C: \pm 100 ppm <small>Improved accuracy/stability available on some models. For example, for \pm7 ppm over 0°C to +50°C and for \pm10ppm over 0°C to +70°C. Improvement is also available over wider temperature ranges. Please contact factory.</small>	
Aging Rate (typical after 30 days)	3 ppm first year 2 ppm/year thereafter	3 ppm first year <2 ppm/year thereafter

[top of page](#)

How to Order Hybrid XO's - CO-400 Series

(Note: Not all combinations possible. See above for appropriate options.)

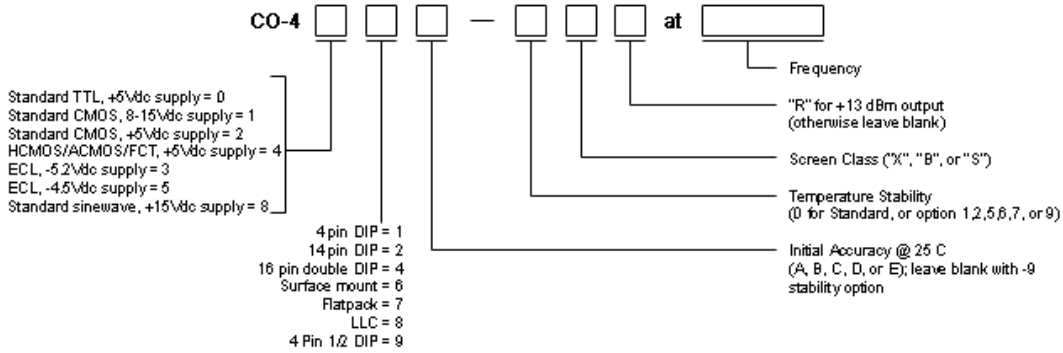

SCREEN TESTING OF ABOVE MODELS					
SCREEN TEST	MIL-STD-883 METHOD	Standard Options			
		CLASS X	CLASS D	CLASS B	CLASS S
Stabilization Bake (150°C)	—	X	X	X	Class S screen test requirements include 24 hour additional bake-out, 80 hour additional burn-in, thermal shock, PIND test and radiographic inspection in addition to Class B Screening. Has major cost impact.
Seal Test (Gross and Fine)	1014, Cond A2	X	X	X	
Temperature Cycling (Thermal Shock)	1010, Cond B		X	X	
Burn-in, operating 160 hours @125°C	—		X	X	
Acceleration (5000g in Y ₁ axis)	2001, Cond A			X	

[top of page](#)

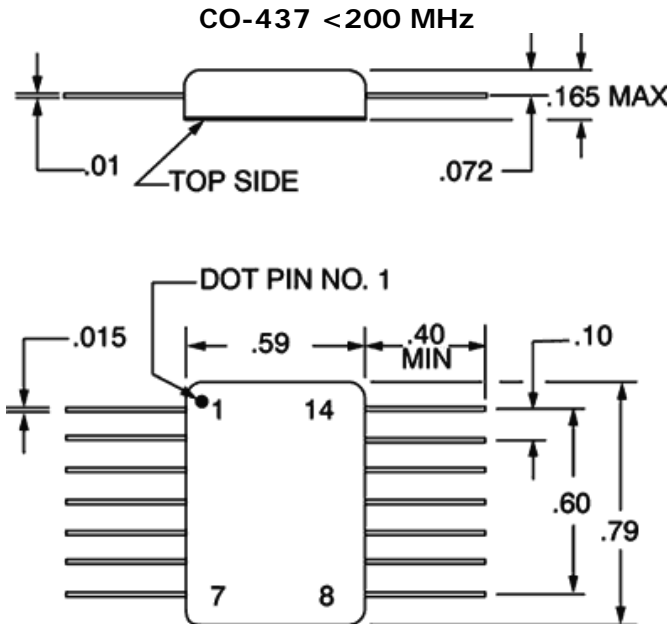

Pinouts

Pin	Function
7	Supply (-)
8	Output

14 OV, case
Other N/C

[top of page](#)

Copyright © 1997-2009 by Vectron International, Inc., [A Dover Company](#).
Vectron International's [Terms and Conditions](#).
The most recent change to this page occurred 02/11/2009