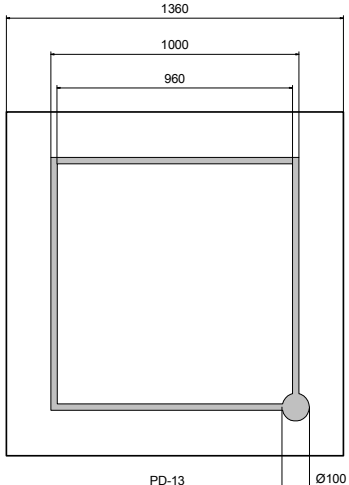

Wavelength range	Type	Technology	Electrodes
Infrared, selective	Integrated filter	AlGaAs/GaAs	P (anode) up

	typ. dimensions (μm)	
	typ. thickness 300 μm anode gold alloy, 1.5 μm cathode gold alloy, 0.5 μm	Description Infrared-selective photo-diode with narrow response range (810 - 950 nm) Applications Optical communications, safety equipment, light barriers

Miscellaneous Parameters

$T_{\text{amb}} = 25^\circ\text{C}$, unless otherwise specified

Parameter	Test conditions	Symbol	Value	Unit
Active area		A	1.79	mm^2
Operating temperature range		T_{amb}	-40 to +125	$^\circ\text{C}$
Storage temperature range		T_{stg}	-40 to +125	$^\circ\text{C}$

Optical and Electrical Characteristics

$T_{\text{amb}} = 25^\circ\text{C}$, unless otherwise specified

Parameter	Test conditions	Symbol	Min	Typ	Max	Unit
Dark current	$V_R = 1\text{ V}$	I_D		1.0	2.5	nA
Peak sensitivity	$V_R = 0\text{ V}$	λ_P		890		nm
Spectral range at 50 %	$V_R = 0\text{ V}$	$\lambda_{0.5}$	820		935	nm
Spectral bandwidth at 50%	$V_R = 0\text{ V}$	$\Delta\lambda_{0.5}$		115		nm
Responsivity at λ_P^1	$V_R = 0\text{ V}$	S_λ		0.27		A/W
Switching time	$V_R = 1\text{ V}$	t_r, t_f		200		ns

¹Measured on bare chip on TO-18 header

Labeling

Type	Typ. I_D [pA]	Typ. S_λ [A/W]	Lot N°	Quantity
EPC-880-1.4				

Packing: Chips on adhesive film with wire-bond side on top

*Note: All measurements carried out with *EPIGAP* equipment

