



DESCRIPTION

The WM8711 is a low power stereo DAC with an integrated headphone driver. The WM8711 is designed specifically for portable MP3 audio and speech players. The WM8711 is also ideal for MD, CD machines and DAT players.

Stereo 24-bit multi-bit sigma delta DACs are used with oversampling digital interpolation filters. Digital audio input word lengths from 16-32 bits and sampling rates from 8KHz to 96KHz are supported.

Stereo audio outputs are buffered for driving headphones from a programmable volume control, line level outputs are also provided along with anti-thump mute and power up/down circuitry.

The device is controlled via a 2 or 3 wire serial interface. The interface provides access to all features including volume controls, mutes, de-emphasis and extensive power management facilities. The device is available in a small 28-pin SSOP package.

A USB mode is provided where all audio rates can be derived from a single 12MHz MCLK, saving on the need for a PLL or multiple crystals.

FEATURES

- Audio Performance
 - 100dB SNR ('A' weighted @ 48kHz) DAC
 - 1.42 – 3.6V Digital Supply Operation
 - 2.7 – 3.6V Analogue Supply Operation
- DAC Sampling Frequency: 8KHz – 96KHz
- 2 or 3-Wire MPU Serial Control Interface
- Programmable Audio Data Interface Modes
 - I²S, Left, Right Justified or DSP
 - 16/20/24/32 bit Word Lengths
 - Master or Slave Clocking Mode
- Stereo Audio Outputs
- Output Volume and Mute Controls
- Highly Efficient Headphone Driver
- Playback Mode Power Consumption < 18mW
- 28-Pin SSOP Package

APPLICATIONS

- Portable MP3 Players
- CD and Minidisc Players

BLOCK DIAGRAM

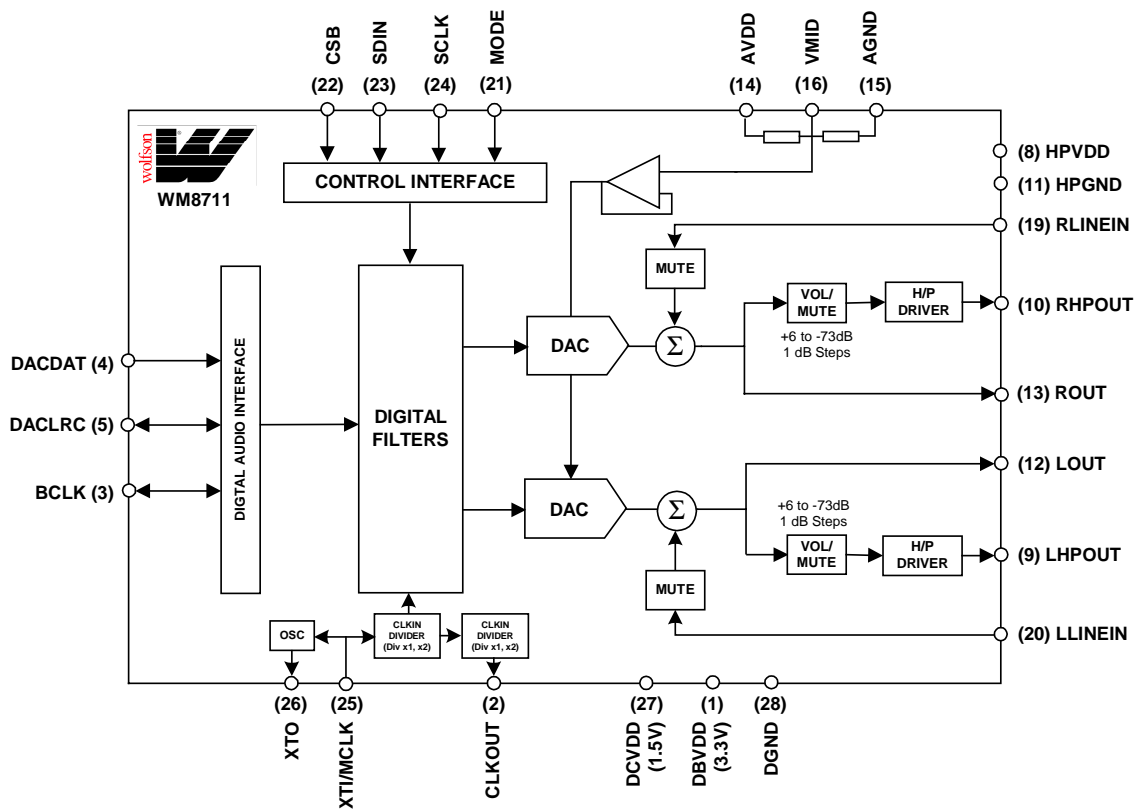

PIN CONFIGURATION

DBVDD	<input type="checkbox"/>	1 ●	28	<input type="checkbox"/>	DGND
CLKOUT	<input type="checkbox"/>	2	27	<input type="checkbox"/>	DCVDD
BCLK	<input type="checkbox"/>	3	26	<input type="checkbox"/>	XTO
DACDAT	<input type="checkbox"/>	4	25	<input type="checkbox"/>	XTI/MCLK
DACLRC	<input type="checkbox"/>	5	24	<input type="checkbox"/>	SCLK
NC	<input type="checkbox"/>	6	23	<input type="checkbox"/>	SDIN
NC	<input type="checkbox"/>	7	22	<input type="checkbox"/>	CSB
HPVDD	<input type="checkbox"/>	8	21	<input type="checkbox"/>	MODE
LHPOUT	<input type="checkbox"/>	9	20	<input type="checkbox"/>	LLINEIN
RHPOUT	<input type="checkbox"/>	10	19	<input type="checkbox"/>	RLINEIN
HPGND	<input type="checkbox"/>	11	18	<input type="checkbox"/>	NC
LOUT	<input type="checkbox"/>	12	17	<input type="checkbox"/>	NC
ROUT	<input type="checkbox"/>	13	16	<input type="checkbox"/>	VMID
AVDD	<input type="checkbox"/>	14	15	<input type="checkbox"/>	AGND

ORDERING INFORMATION

DEVICE	TEMP. RANGE	PACKAGE
XWM8711EDS	-10 to +70°C	28-pin SSOP

PIN DESCRIPTION

PIN	NAME	TYPE	DESCRIPTION
1	DBVDD	Supply	Digital Buffers VDD
2	CLKOUT	Digital Output	Buffered Clock Output
3	BCLK	Digital Input/Output	Digital Audio Bit Clock, Pull Down (see Note 1)
4	DACDAT	Digital Input	DAC Digital Audio Data Input
5	DACLRC	Digital Input/Output	DAC Sample Rate Left/Right Clock, Pull Down (see Note 1)
6		NC	No Connection
7		NC	No Connection
8	HPVDD	Supply	Headphone VDD
9	LHPOUT	Analogue Output	Left Channel Headphone Output
10	RHPOUT	Analogue Output	Right Channel Headphone Output
11	HPGND	Ground	Headphone GND
12	LOUT	Analogue Output	Left Channel Line Output
13	ROUT	Analogue Output	Right Channel Line Output
14	AVDD	Supply	Analogue VDD
15	AGND	Ground	Analogue GND
16	VMID	Analogue Output	Mid-rail reference decoupling point
17		NC	No Connection
18		NC	No Connection
19	RLINEIN	Analogue Input	Right Channel Line Input (AC coupled)
20	LLINEIN	Analogue Input	Left Channel Line Input (AC coupled)
21	MODE	Digital Input	Control Interface Selection, Pull up (see Note 1)
22	CSB	Digital Input	3-Wire MPU Chip Select/ 2-Wire MPU interface address selection, active low, Pull up (see Note 1)
23	SDIN	Digital Input	3-Wire MPU Data Input / 2-Wire MPU Data Input
24	SCLK	Digital Input	3-Wire MPU Clock Input / 2-Wire MPU Clock Input
25	XTI/MCLK	Digital Input	Crystal Input or Master Clock Input (MCLK)
26	XTO	Digital Output	Crystal Output
27	DCVDD	Supply	Digital Core VDD
28	DGND	Ground	Digital GND

Note:

1. Pull Up/Down only present when Control Register Interface ACTIVE=0 to conserve power.

ABSOLUTE MAXIMUM RATINGS

Absolute Maximum Ratings are stress ratings only. Permanent damage to the device may be caused by continuously operating at or beyond these limits. Device functional operating limits and guaranteed performance specifications are given under Electrical Characteristics at the test conditions specified.



ESD Sensitive Device. This device is manufactured on a CMOS process. It is therefore generically susceptible to damage from excessive static voltages. Proper ESD precautions must be taken during handling and storage of this device.

CONDITION	MIN	MAX
Digital supply voltage	-0.3V	+3.63V
Analogue supply voltage	-0.3V	+3.63V
Voltage range digital inputs	DGND -0.3V	DVDD +0.3V
Voltage range analogue inputs	AGND -0.3V	AVDD +0.3V
Master Clock Frequency (see Note 4)		40MHz
Operating temperature range, T _A	-10°C	+70°C
Storage temperature	-65°C	+150°C
Package body temperature (soldering 10 seconds)		+240°C
Package body temperature (soldering 2 minutes)		+183°C

Notes:

1. Analogue and digital grounds must always be within 0.3V of each other.
2. The digital supply core voltage (DCVDD) must always be less than or equal to the analogue supply voltage (AVDD) or digital supply buffer voltage (DBVDD).
3. The digital supply buffer voltage (DBVDD) must always be less than or equal to the analogue supply voltage (AVDD).
4. When CLKIDIV2 = 1.

RECOMMENDED OPERATING CONDITIONS

PARAMETER	SYMBOL	TEST CONDITIONS	MIN	TYP	MAX	UNIT
Digital supply range (Core)	DCVDD		1.42		3.6	V
Digital supply range (Buffer)	DBVDD		2.7		3.6	V
Analogue supply range	AVDD, HPVDD		2.7		3.6	V
Ground	DGND,AGND,HPGND			0		V
Total analogue supply current	IAVDD, IHPVDD	DCVDD, DBVDD, AVDD, HPVDD= 3.3V		8		mA
Digital supply current	IDCVDD, IDBVDD	DCVDD, DBVDD, AVDD, HPVDD= 3.3V		3		mA
Standby Current Consumption				10		uA

ELECTRICAL CHARACTERISTICS

Test Conditions

AVDD, HPVDD, DBVDD = 3.3V, AGND = 0V, DCVDD = 1.5V, DGND = 0V, T_A = +25°C, Slave Mode, fs = 48kHz, MCLK = 256fs unless otherwise stated.

PARAMETER	SYMBOL	TEST CONDITIONS	MIN	TYP	MAX	UNIT
Digital Logic Levels (CMOS Levels)						
Input LOW level	V _{IL}				.3 x DBVDD	V
Input HIGH level	V _{IH}		.7 x DBVDD			V
Output LOW	V _{OL}				0.10 x DBVDD	V
Output HIGH	V _{OH}		.9 x DBVDD			V
Power On Reset Threshold (DCVDD)						
DCVDD Threshold On -> Off	V _{th}		0.7	0.9	1.2	V
Hysteresis	V _{IH}			0.3		V
DCVDD Threshold Off -> On	V _{OL}			0.6		V
Analogue Reference Levels						
Reference voltage	V _{VMID}		AVDD/2 – 50mV	AVDD/2	AVDD/2 + 50mV	V
Potential divider resistance	R _{VMID}		40K	50K	60K	Ohms
Line Output for DAC Playback Only (Load = 10K ohms. 50pF)						
0dBfs Full scale output voltage		At LINE outputs		1.0 x AVDD/3.3		V _{rms}
SNR (Note 1,2)		A-weighted, @ fs = 48KHz	90	100		dB
SNR (Note 1,2)		A-weighted @ fs = 96KHz		98		dB
SNR (Note 1,2)		A-weighted, @ fs = 48KHz, AVDD = 2.7V		93		dB
Dynamic Range (Note 2)	DNR	A-weighted, -60dB full scale input	85	90		dB
THD		1KHz, 0dBfs		-88	-80	dB
		1kHz, -3dBfs		-92	-86	dB
Power Supply Rejection Ratio	PSSR	1kHz 100mVpp		50		dB
		20Hz to 20kHz 100mVpp		45		dB
DAC channel separation				100		dB

Test Conditions

AVDD, HPVDD, DBVDD = 3.3V, AGND = 0V, DCVDD = 1.5V, DGND = 0V, T_A = +25°C, Slave Mode, fs = 48kHz, MCLK = 256fs unless otherwise stated.

PARAMETER	SYMBOL	TEST CONDITIONS	MIN	TYP	MAX	UNIT
Stereo Headphone Output						
0dB Full scale output voltage				1.0 x AVDD/3.3		Vrms
Max Output Power RL = 32 ohms	P _O			30		mW
Max Output Power RL = 16 ohms	P _O			40		mW
SNR (Note 1,2)		A-weighted	90	97		dB
THD		1kHz, R _L = 32 ohms @ P _O = 10mW rms		0.1 60	0.1 60	% dB
		1kHz, R _L = 32 ohms @ P _O = 20mW rms		1.0 40	1.0 40	% dB
Power Supply Rejection Ratio	PSSR	1kHz 100mVpp		50		dB
		20Hz to 20kHz 100mVpp		45		dB
Programmable Gain Maximum		1kHz		6		dB
Programmable Gain Minimum				-73		
Programmable Gain Step Size		1kHz		1		dB
Mute attenuation		1kHz, 0dB		80		dB

Notes:

- Ratio of output level with 1kHz full scale input, to the output level with all zeros into the digital input, measured 'A' weighted over a 20Hz to 20kHz bandwidth.
- All performance measurements done with 20kHz low pass filter, and where noted an A-weight filter. Failure to use such a filter will result in higher THD+N and lower SNR and Dynamic Range readings than are found in the Electrical Characteristics. The low pass filter removes out of band noise; although it is not audible it may affect dynamic specification values.
- VMID decoupled with 10uF and 0.1uF capacitors (smaller values may result in reduced performance).

TERMINOLOGY

- Signal-to-noise ratio (dB) - SNR is a measure of the difference in level between the full scale output and the output with no signal applied. (No Auto-zero or Automute function is employed in achieving these results).
- Dynamic range (dB) - DNR is a measure of the difference between the highest and lowest portions of a signal. Normally a THD+N measurement at 60dB below full scale. The measured signal is then corrected by adding the 60dB to it. (e.g. THD+N @ -60dB = -32dB, DR = 92dB).
- THD+N (dB) - THD+N is a ratio, of the rms values, of (Noise + Distortion)/Signal.
- Stop band attenuation (dB) - Is the degree to which the frequency spectrum is attenuated (outside audio band).
- Channel Separation (dB) - Also known as Cross-Talk. This is a measure of the amount one channel is isolated from the other. Normally measured by sending a full scale signal down one channel and measuring the other.
- Pass-Band Ripple - Any variation of the frequency response in the pass-band region.

POWER CONSUMPTION

MODE DESCRIPTION	POWEROFF	CLKOUTPD	OSCPD	OUTPD	DACPD	CURRENT CONSUMPTION			
						MIN	TYP	MAX	UNITS
Playback	0	0	0	0	0		7		mA
Playback Oscillator and CLKOUT disabled	0	1	1	0	0		6		mA
Standby	0	1	1	1	1		0.05		mA
Power Down	1	X	X	X	1		0.01		mA

Table 1 Powerdown Mode Current Consumption Examples

Notes:

1. AVDD, HPVDD, DBVDD = 3.3V, AGND = 0V, DCVDD = 1.5V, DGND = 0V, T_A = +25°C. Slave Mode, fs = 48kHz, MCLK = 256fs (12.288MHz).
2. All figures are quiescent, with no signal.
3. The power dissipation in the headphone itself not included in the above table.

MASTER CLOCK TIMING

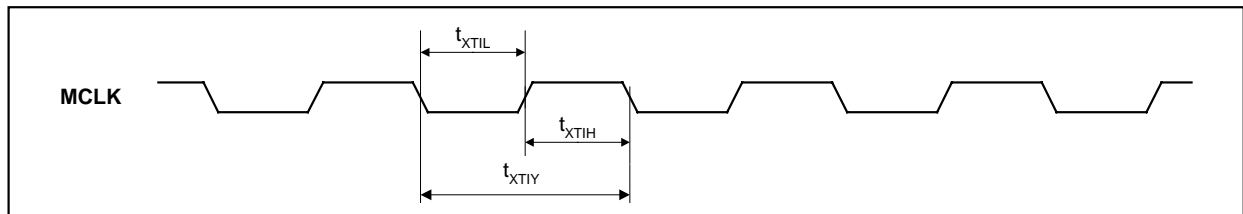

Figure 1 System Clock Timing Requirements

Test Conditions

AVDD, HPVDD, DBVDD = 3.3V, AGND = 0V, DCVDD = 1.5V, DGND = 0V, T_A = +25°C, Slave Mode fs = 48kHz, MCLK = 256fs unless otherwise stated.

PARAMETER	SYMBOL	TEST CONDITIONS	MIN	TYP	MAX	UNIT
System Clock Timing Information						
MCLK System clock pulse width high	T _{XTIH}		18			ns
MCLK System clock pulse width low	T _{XTIL}		18			ns
MCLK System clock cycle time	T _{XTIY}		54			ns
MCLK Duty cycle			40:60		60:40	

DIGITAL AUDIO INTERFACE – MASTER MODE

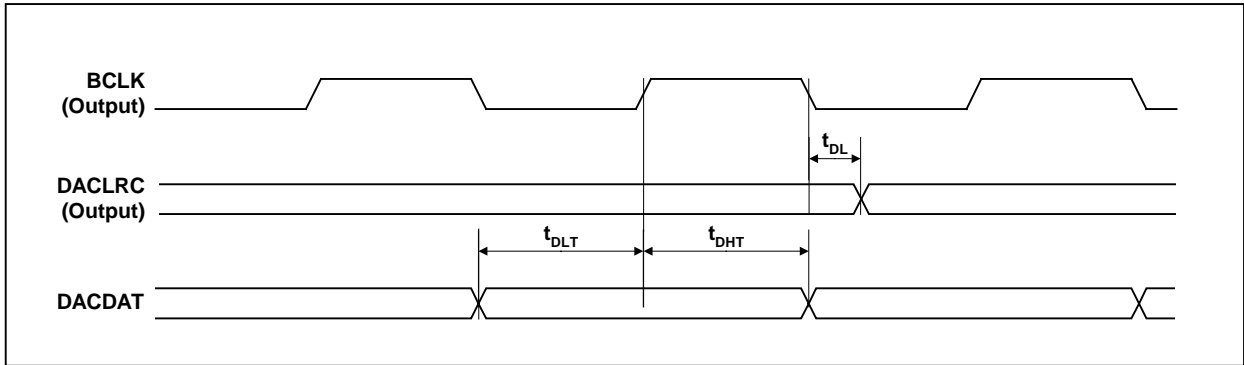

Figure 2 Digital Audio Data Timing - Master Mode

Test Conditions

AVDD, HPVDD, DVDD = 3.3V, AGND = 0V, DCVDD = 1.5V, DGND = 0V, T_A = +25°C, Slave Mode, fs = 48kHz, XT1/MCLK = 256fs unless otherwise stated.

PARAMETER	SYMBOL	TEST CONDITIONS	MIN	TYP	MAX	UNIT
Audio Data Input Timing Information						
DACLRC propagation delay from BCLK falling edge	t _{DL}		0		10	ns
DACDAT setup time to BCLK rising edge	t _{DST}		10			ns
DACDAT hold time from BCLK rising edge	t _{DHT}		10			ns

DIGITAL AUDIO INTERFACE – SLAVE MODE

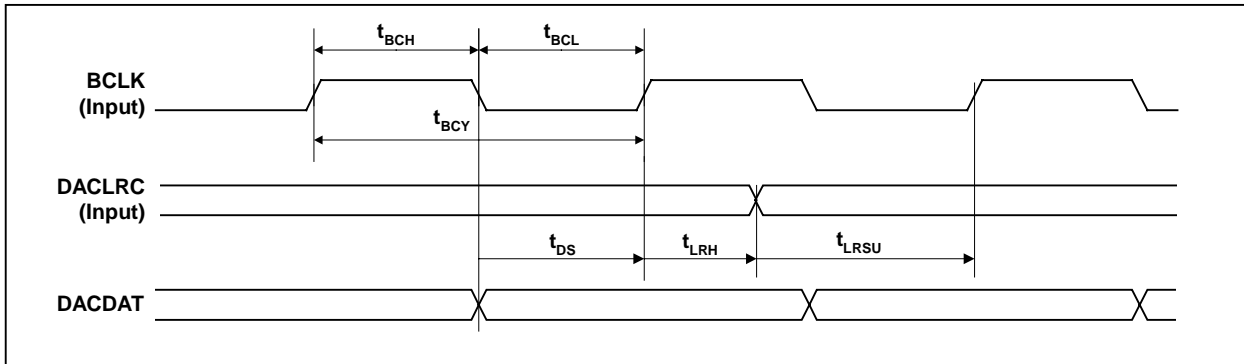

Figure 3 Digital Audio Data Timing – Slave Mode

Test Conditions

AVDD, HPVDD, DVDD = 3.3V, AGND = 0V, DCVDD = 1.5V, DGND = 0V, T_A = +25°C, slave mode, fs = 48kHz, MCLK = 256fs unless otherwise stated.

PARAMETER	SYMBOL	TEST CONDITIONS	MIN	TYP	MAX	UNIT
Audio Data Input Timing Information						
BCLK cycle time	t _{BCY}		50			ns
BCLK pulse width high	t _{BCH}		20			ns
BCLK pulse width low	t _{BCL}		20			ns
DACLRC set-up time to BCLK rising edge	t _{LRSU}		10			ns
DACLRC hold time from BCLK rising edge	t _{LRH}		10			ns
DACDAT set-up time to BCLK rising edge	t _{DS}		10			ns

Test Conditions

AVDD, HPVDD, DVDD = 3.3V, AGND = 0V, DCVDD = 1.5V, DGND = 0V, T_A = +25°C, slave mode, fs = 48kHz, MCLK = 256fs unless otherwise stated.

PARAMETER	SYMBOL	TEST CONDITIONS	MIN	TYP	MAX	UNIT
DACDAT hold time from BCLK rising edge	t _{DH}		10			ns

MPU INTERFACE TIMING

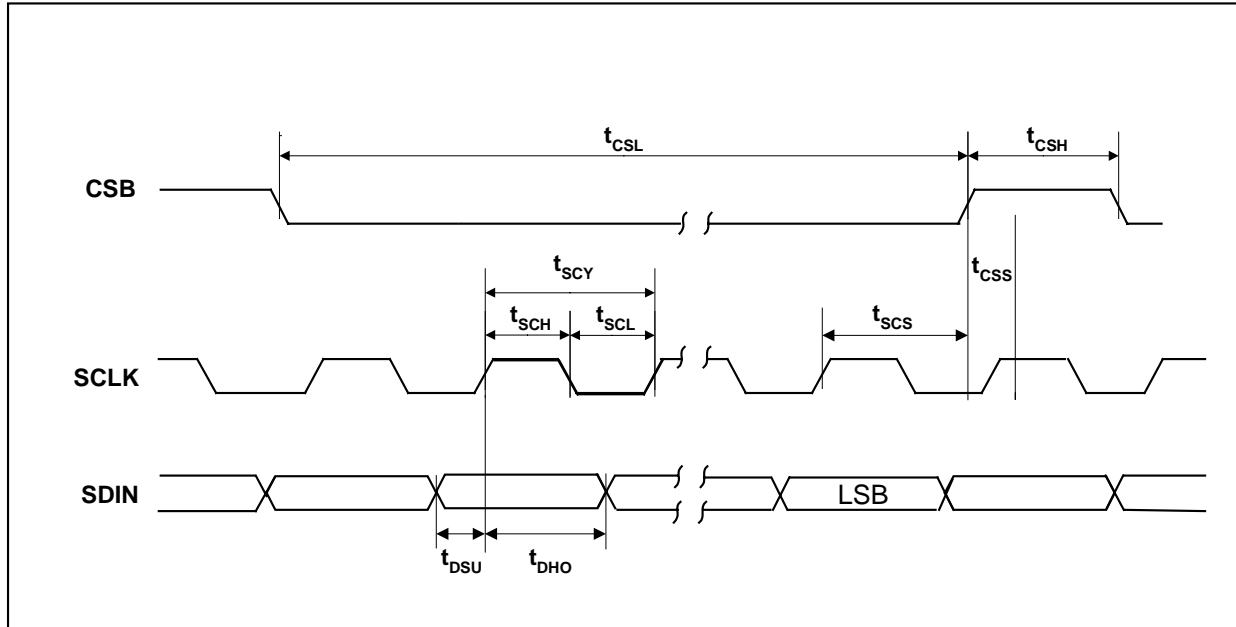

Figure 4 Program Register Input Timing - 3-Wire MPU Serial Control Mode

Test Conditions

AVDD, HPVDD, DBVDD = 3.3V, AGND = 0V, DCVDD = 1.5V, DGND = 0V, T_A = +25°C, Slave Mode, fs = 48kHz, MCLK = 256fs unless otherwise stated.

PARAMETER	SYMBOL	TEST CONDITIONS	MIN	TYP	MAX	UNIT
Program Register Input Information						
SCLK rising edge to CSB rising edge	t _{SCS}		60			ns
SCLK pulse cycle time	t _{SCY}		80			ns
SCLK pulse width low	t _{SCL}		20			ns
SCLK pulse width high	t _{SCH}		20			ns
SDIN to SCLK set-up time	t _{DSU}		20			ns
SCLK to SDIN hold time	t _{DHO}		20			ns
CSB pulse width low	t _{CSL}		20			ns
CSB pulse width high	t _{CSH}		20			ns
CSB rising to SCLK rising	t _{CSS}		20			ns

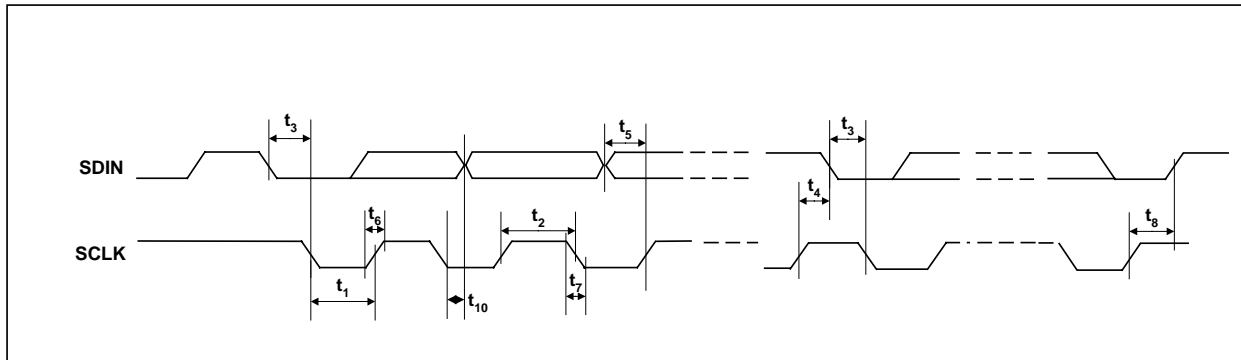

Figure 5 Program Register Input Timing – 2-Wire MPU Serial Control Mode

Test Conditions

AVDD, HPVDD, DBVDD = 3.3V, AGND = 0V, DCVDD = 1.5V, DGND = 0V, T_A = +25°C, Slave Mode, fs = 48kHz, MCLK = 256fs unless otherwise stated.

PARAMETER	SYMBOL	TEST CONDITIONS	MIN	TYP	MAX	UNIT
Program Register Input Information						
SCLK Frequency			0		400	kHz
SCLK Low Pulsewidth	t ₁		600			ns
SCLK High Pulsewidth	t ₂		1.3			us
Hold Time (Start Condition)	t ₃		600			ns
Setup Time (Start Condition)	t ₄		600			ns
Data Setup Time	t ₅		100			ns
SDIN, SCLK Rise Time	t ₆				300	ns
SDIN, SCLK Fall Time	t ₇				300	ns
Setup Time (Stop Condition)	t ₈		600			ns
Data Hold Time	t ₁₀				900	ns

DEVICE DESCRIPTION

INTRODUCTION

The WM8711 is a low power audio DAC designed specifically for portable audio products. Its features, performance and low power consumption make it ideal for portable MP3, CD and mini-disc players.

The WM8711 includes line and headphone outputs from the on-board DAC, configurable digital audio interface and a choice of 2 or 3 wire MPU control interface. It is fully compatible and an ideal partner for a range of industry standard microprocessors, controllers and DSPs.

The on-board digital to analogue converter (DAC) accepts digital audio from the digital audio interface. Digital filter de-emphasis at 32kHz, 44.1kHz and 48kHz can be applied to the digital data under software control. The DAC employs a high quality multi-bit high-order oversampling architecture to again deliver optimum performance with low power consumption.

The DAC outputs and Line Inputs (BYPASS) are available both at line level and through a headphone amplifier capable of efficiently driving low impedance headphones. The headphone output volume is adjustable in the analogue domain over a range of +6dB to -73dB and can be muted.

The design of the WM8711 minimises power consumption without compromising performance. It includes the ability to power off selective parts of the circuitry under software control, thus conserving power. Separate power save modes can be configured under software control including a standby and power off mode.

Special techniques allow the audio to be muted and the device safely placed into standby, sections of the device powered off, volume levels adjusted without any audible clicks, pops or zipper noises. Therefore standby and power off modes may be used dynamically under software control, whenever playback is not required.

The device caters for a number of different sampling rates including industry standard 8kHz, 32kHz, 44.1kHz, 48kHz, 88.2kHz and 96kHz. The WM8711 has two schemes to support the programmable sample rates: Normal industry standard 256/384 fs sampling mode may be used. A special USB mode is included, where all audio sampling rates can be generated from a 12.00MHz USB clock. The digital filters used for playback are optimised for each sampling rate used.

The digital audio interface can support a range of audio data formats including I2S, DSP Mode (a burst mode in which frame sync plus 2 data packed words are transmitted), MSB-First, left justified and MSB-First, right justified. The digital audio interface can operate in both master or slave modes.

The software control uses either a 2 or 3-wire MPU interface.

AUDIO SIGNAL PATH

DAC FILTERS

The DAC filters perform true 24 bit signal processing to convert the incoming digital audio data from the digital audio interface at the specified sample rate to multi-bit oversampled data for processing by the analogue DAC. Figure 6 illustrates the DAC digital filter path.

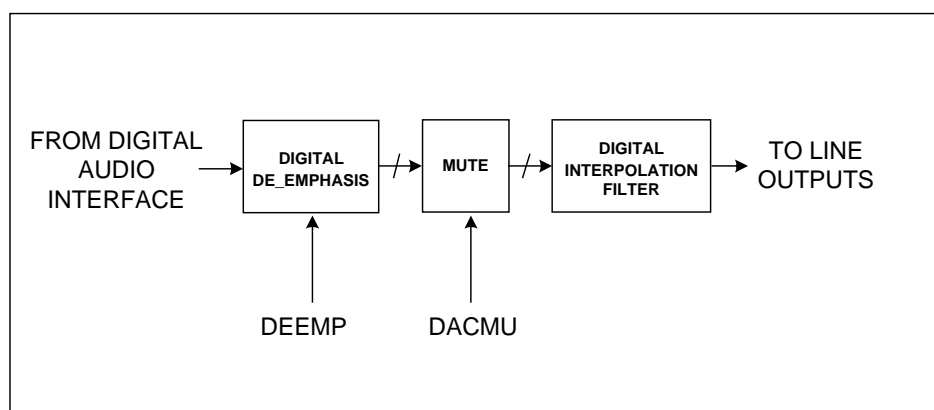

Figure 6 DAC Filter Schematic

The DAC digital filter can apply digital de-emphasis under software control, as shown in Table 2. The DAC can also perform a soft mute where the audio data is digitally brought to a mute level. This removes any abrupt step changes in the audio that might otherwise result in audible clicks in the audio outputs.

REGISTER ADDRESS	BIT	LABEL	DEFAULT	DESCRIPTION
0000101 Digital Audio Path Control	2:1	DEEMP[1:0]	00	De-emphasis Control (Digital) 11 = 48KHz 10 = 44.1KHz 01 = 32KHz 00 = Disable
	3	DACMU	1	DAC Soft Mute Control (Digital) 1 = Enable soft mute 0 = Disable soft mute

Table 2 DAC Software Control

DAC

The WM8711 employs a multi-bit sigma delta oversampling digital to analogue converter. The scheme for the converter is illustrated in Figure 7.

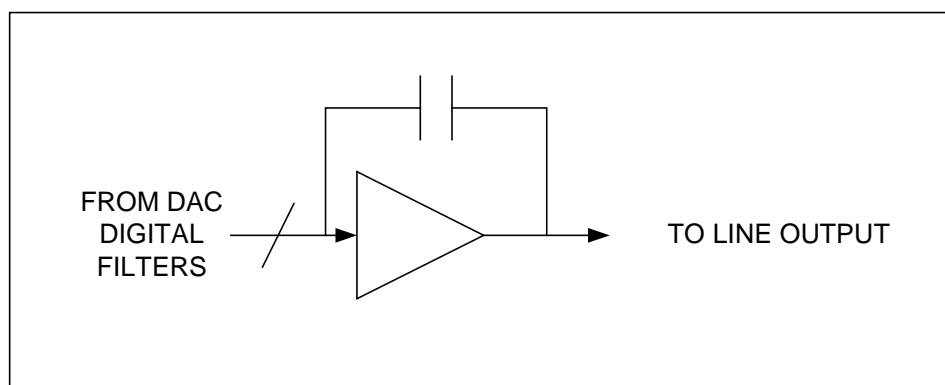

Figure 7 Multi-Bit Oversampling Sigma Delta Schematic

The DAC converts the multi-level digital audio data stream from the DAC digital filters into high quality analogue audio.

LINE OUTPUTS

The WM8711 provides two low impedance line outputs LLINEOUT and RLINEOUT, suitable for driving typical line loads of impedance 10K and capacitance 50pF.

The LLINEOUT and RLINEOUT outputs are only available at a line output level and are not level adjustable in the analogue domain, having a fixed gain of 0dB. The level is fixed such that at the DAC full scale level the output level is V_{rms} at $AVDD = 3.3$ volts. Note that the DAC full scale level tracks directly with $AVDD$. The scheme is shown in Figure 8. The line output includes a low order audio low pass filter for removing out-of band components from the sigma-delta DAC. Therefore no further external filtering is required in most applications.

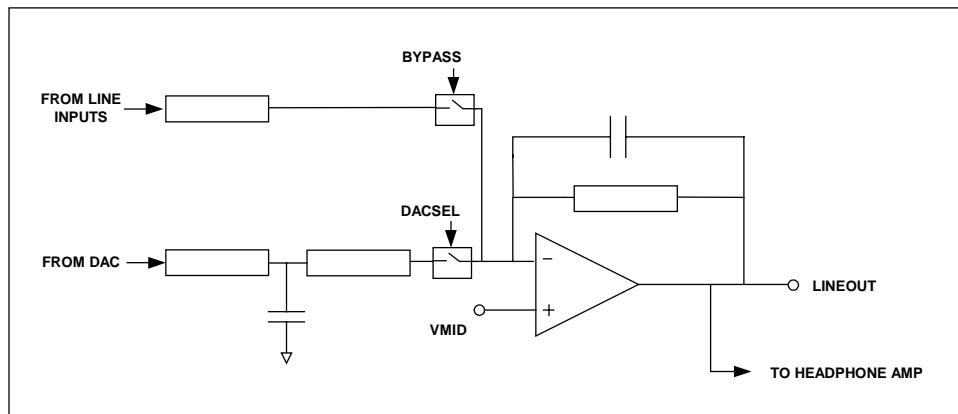

Figure 8 Line Output Schematic

The line output is muted by either muting the DAC (analogue) or Soft Muting (digital) and disabling the BYPASS path. Refer to the DAC section for more details. Whenever the DAC is muted or the device placed into standby mode the DC voltage is maintained at the line outputs to prevent any audible clicks from being present.

The software control for the line outputs is shown in Table 3.

REGISTER ADDRESS	BIT	LABEL	DEFAULT	DESCRIPTION
0000100 Analogue Audio Path Control	3	BYPASS	1	Bypass Switch 1 = Enable Bypass 0 = Disable Bypass
	4	DACSEL	0	DAC Select 1 = Select DAC 0 = Don't select DAC

Table 3 Output Software Control

The recommended external components are shown in Figure 9.

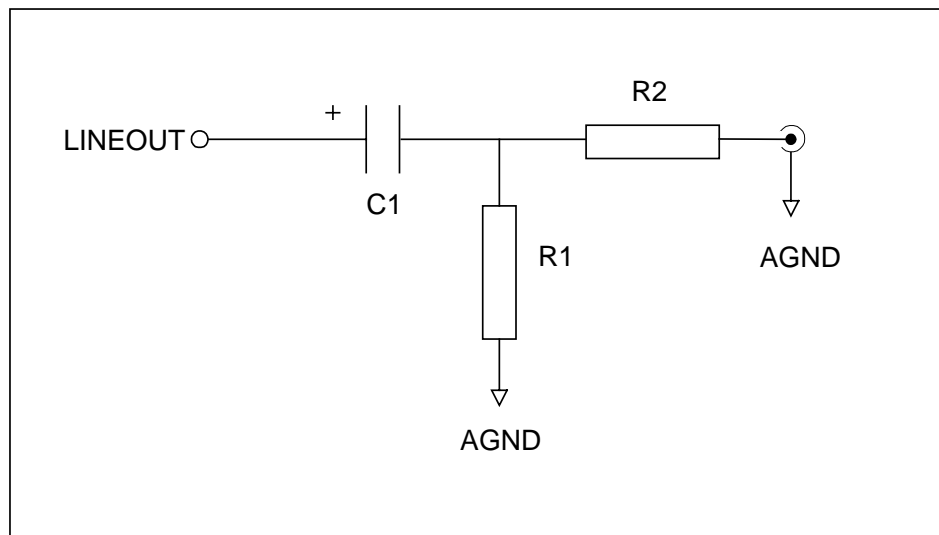

Figure 9 Line Outputs Application Drawing

Recommended values are C1 = 470nF (10V npo type), R1 = 47KOhms, R2 = 100 Ohms

C1 forms a DC blocking capacitor to the line outputs. R1 prevents the output voltage from drifting so protecting equipment connected to the line output. R2 forms a de-coupling resistor preventing abnormal loads from disturbing the device. Note that poor choice of dielectric material for C1 can have dramatic effects on the measured signal distortion at the output.

HEADPHONE AMPLIFIER

The WM8711 has a stereo headphone output available on LHPOUT and RHPOUT. The output is designed specifically for driving 16 or 32 ohm headphones with maximum efficiency and low power consumption. The headphone output includes a high quality volume level adjustment and mute function.

The scheme of the circuit is shown in Figure 10.

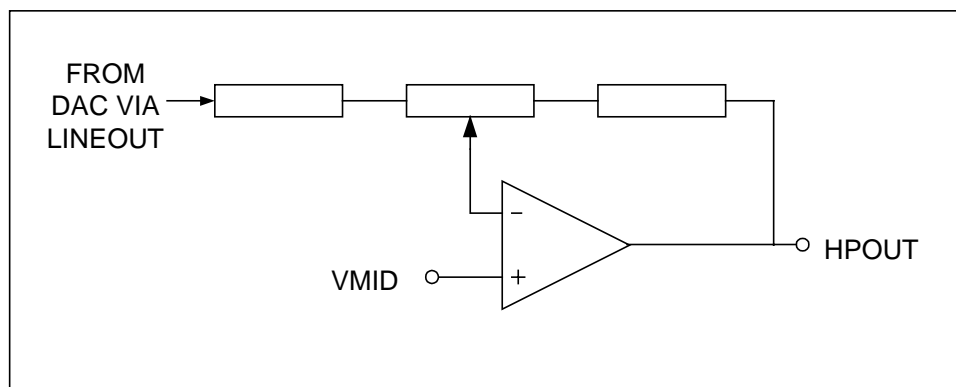

Figure 10 Headphone Amplifier Schematic

LHPOUT and RHPOUT volumes can be independently adjusted under software control using the LHPVOL[6:0] and RHPVOL[6:0] bits respectively of the headphone output control registers. The adjustment is logarithmic with an 80dB range in 1dB steps from +6dB to -73dB.

The headphone outputs can be separately muted by writing codes less than 0110000 to LHPVOL[6:0] or RHPVO[6:0]L bits. Whenever the headphone outputs are muted or the device placed into standby mode, the DC voltage is maintained at the line outputs to prevent any audible clicks from being present.

A zero cross detect circuit is provided at the input to the headphones under the control of the LZCEN and RZCEN bits of the headphone output control register. Using these controls the volume control values are only updated when the input signal to the gain stage is close to the analogue ground level. This minimises and audible clicks and zipper noise as the gain values are changed or the device muted. Note that this circuit has no time out so if only DC levels are being applied to the gain stage input of more than approximately 20mv, then the gain will not be updated. This zero cross function is enabled when the LZCEN and RZCEN bit is set high during a volume register write. If there is concern that a DC level may have blocked a volume change (one made with LZCEN or RZCEN set high) then a subsequent volume write of the same value, but with the LZCEN or RZCEN bit set low will force a volume update, regardless of the DC level.

LHPOUT and RHPOUT volume and zero-cross setting can be changed independently. Alternatively, the user can lock the two channels together, allowing both to be updated simultaneously, halving the number of serial writes required, provided that the same gain is needed for both channels. This is achieved through writing to the HPBOTH bit of the control register. Setting LRHPBOTH whilst writing to LHPVOL and LZCEN will simultaneously update the Right Headphone controls similarly. The corresponding effect on updating RLHPBOTH is also achieved.

The software control is given in Table 4.

REGISTER ADDRESS	BIT	LABEL	DEFAULT	DESCRIPTION
0000010 Left Headphone Out	6:0	LHPVOL[6:0]	1111001 (0dB)	Left Channel Headphone Output Volume Control 1111111 = +6dB .. 1dB steps down to 0110000 = -73dB 0000000 to 0101111 = MUTE
	7	LZCEN	1	Left Channel Zero Cross detect Enable 1 = Enable 0 = Disable
	8	LRHPBOTH	0	Left to Right Channel Headphone Volume, Mute and Zero Cross Data Load Control 1 = Enable Simultaneous Load of LHPVOL[6:0] and LZCEN to RHPVOL[6:0] and RZCEN 0 = Disable Simultaneous Load
0000011 Right Headphone Out	6:0	RHPVOL[7:0]	1111001 (0dB)	Right Channel Headphone Output Volume Control 1111111 = +6dB .. 1dB steps down to 0110000 = -73dB 0000000 to 0101111 = MUTE
	7	RZCEN	1	Right Channel Zero Cross Detect Enable 1 = Enable 0 = Disable
	8	RLHPBOTH	0	Right to Left Channel Headphone Volume, Mute and Zero Cross Data Load Control 1 = Enable Simultaneous Load of RHPVOL[6:0] and RZCEN to LHPVOL[6:0] and LZCEN 0 = Disable Simultaneous Load

Table 4 Headphone Output Software Control

The recommended external components required to complete the application are shown in Figure 11.

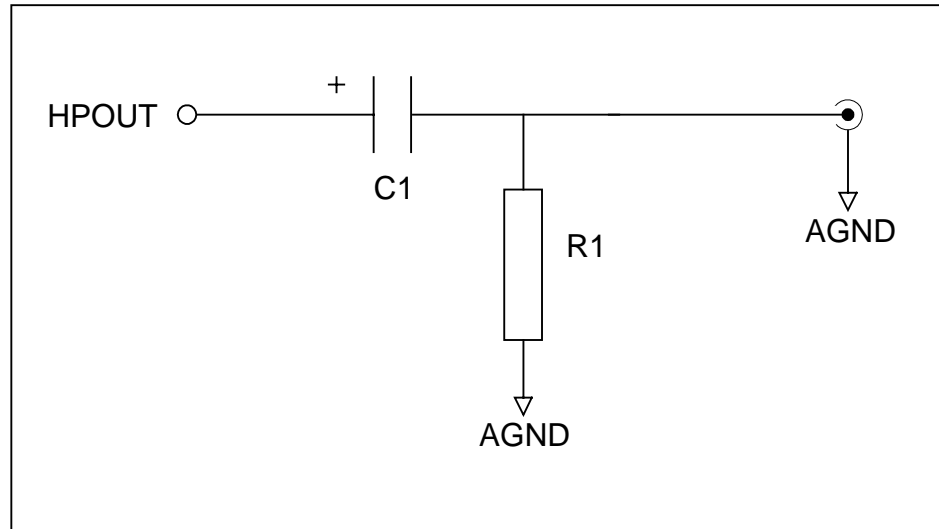

Figure 11 Headphone Output Application Drawing

Recommended values are C1 = 220uF (10V electrolytic), R1 = 47KOhms

C1 forms a DC blocking capacitor to isolate the dc of the HPOUT from the headphones. R1 form a pull down resistor to discharge C1 to prevent the voltage at the connection to the headphones from rising to a level that may damage the headphones. L1 (optional) forms a phase shifting network with the headphone load aiding overall performance, and increasing the protection of the WM8711 headphone amplifier from potentially destructive externally applied electrostatic discharge events.

DEVICE OPERATION

DEVICE RESETTING

The WM8711 contains a power on reset circuit that resets the internal state of the device to a known condition. The power on reset is applied as DCVDD powers on and released only after the voltage level of DCVDD crosses a minimum turn off threshold. If DCVDD later falls below a minimum turn on threshold voltage then the power on reset is re-applied. The threshold voltages and associated hysteresis are shown in the Electrical Characteristics table.

The user also has the ability to reset the device to a known state under software control as shown in the table below.

REGISTER ADDRESS	BIT	LABEL	DEFAULT	DESCRIPTION
0001111 Reset Register	8:0	RESET	not reset	Reset Register Writing 00000000 to register resets device

Table 5 Software Control of Reset

When using the software reset. In 3-wire mode the reset is applied on the rising edge of CSB and released on the next rising edge of SCLK. In 2-wire mode the reset is applied for the duration of the ACK signal (approximately 1 SCLK period, refer to Figure 20).

CLOCKING SCHEMES

In a typical digital audio system there is only one central clock source producing a reference clock to which all audio data processing is synchronised. This clock is often referred to as the audio system's Master Clock. To allow WM8711 to be used in a centrally clocked system, the WM8711 is capable of either generating this system clock itself or receiving it from an external source as will be discussed.

For applications where it is desirable that the WM8711 is the system clock source, then clock generation is achieved through the use of a suitable crystal connected between the XT1/MCLK input and XTO output pins (see CRYSTAL OSCILLATOR section).

For applications where a component other than the WM8711 will generate the reference clock, the external system Master Clock can be applied directly through the XTI/MCLK input pin with no software configuration necessary. Note that in this situation, the oscillator circuit of the WM8711 can be safely powered down to conserve power (see POWER DOWN section)

CORE CLOCK

The WM8711 DSP core can be clocked either by MCLK or MCLK divided by 2. This is controlled by software as shown in Table 6 below.

REGISTER ADDRESS	BIT	LABEL	DEFAULT	DESCRIPTION
0001000 Sampling Control	6	CLKIDIV2	0	Core Clock divider select 1 = Core Clock is MCLK divides by 2 0 = Core Clock is MCLK

Table 6 Software Control of Core Clock

Having a programmable MCLK divider allows the device to be used in applications where higher frequency master Clocks are available. For example the device can support 512Fs master clocks whilst fundamentally operating in a 256Fs mode.

CRYSTAL OSCILLATOR

The WM8711 includes a crystal oscillator circuit that allows the audio system's reference clock to be generated on the device. This is available to the rest of the audio system in buffered form on CLKOUT. The crystal oscillator is a low radiation type, designed for low EMI. A typical application circuit is shown Figure 12.

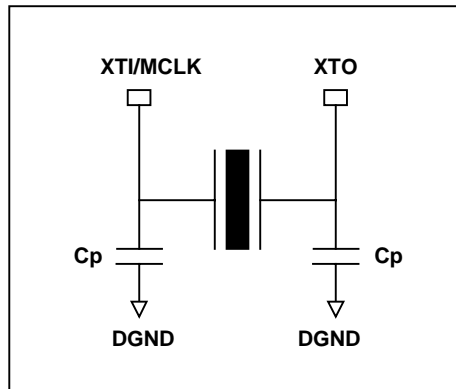

Figure 12 Crystal Oscillator Application Circuit

For crystal frequencies in the 12MHz range, a Cp of 10pF is recommended. For crystal frequencies in the 18MHz range, 15pF Cp is recommended.

The WM8711 crystal oscillator provides an extremely low jitter clock source. Low jitter clocks are a requirement for high quality audio DACs, regardless of the converter architecture. The WM8711 architecture is less susceptible than most converter techniques but still requires clocks with less than approximately 1ns of jitter to maintain performance. In applications where there is more than one source for the master clock, it is recommended that the clock is generated by the WM8711 to minimise such problems.

CLOCKOUT

The Core Clock is internally buffered and made available externally to the audio system on the CLKOUT output pin. CLKOUT provides a replication of the Core Clock, but buffered as suitable for driving external loads.

There is no phase inversion between XTI/MCLK, the Core Clock and CLOCKOUT but there will inevitably be some delay. The delay will be dependent on the load that CLOCKOUT drives. Refer to Electrical Characteristics.

CLKOUT can also be divided by 2 under software control, refer to Table 7. Note that if CLKOUT is not required then the CLKOUT buffer on the WM8711 can be safely powered down to conserve power (see POWER DOWN section). If the system architect has the choice between using $F_{CLKOUT} = F_{MCLK}$ or $F_{CLKOUT} = F_{MCLK}/2$ in the interface, the latter is recommended to conserve power. When the divide by two is selected CLKOUT changes on the rising edge of MCLK. Please refer to Electrical Characteristics for timing information.

REGISTER ADDRESS	BIT	LABEL	DEFAULT	DESCRIPTION
0001000 Sampling Control	7	CLKODIV2	0	CLKOUT divider select 1 = CLOCKOUT is Core Clock divides by 2 0 = CLOCKOUT is Core Clock

Table 7 Programming CLKOUT

CLKOUT is disabled and set low whenever the device is in reset.

DIGITAL AUDIO INTERFACES

WM8711 may be operated in either one of the 4 offered audio interface modes. These are:

- Right justified
- Left justified
- I2S
- DSP mode

All four of these modes are MSB first and operate with data 16 to 32 bits, except in right justified mode where 32 bit data is not supported.

The digital audio interface receives the digital audio data for the internal DAC digital filters on the DACDAT input. DACDAT is the formatted digital audio data stream output to the DAC digital filters with left and right channels multiplexed together. DACLRC is an alignment clock that controls whether Left or Right channel data is present on DATDAT. DACDAT and DACLRC are synchronous with the BCLK signal with each data bit transition signified by a BCLK transition. DACDAT is always an input. BCLK and DACLRC are either outputs or inputs depending whether the device is in master or slave mode. Refer to the MASTER/SLAVE OPERATION section

There are four digital audio interface formats accommodated by the WM8711. These are shown in the figures below. Refer to the Electrical Characteristic section for timing information.

Left Justified mode is where the MSB is available on the first rising edge of BCLK following a DACLRC transition.

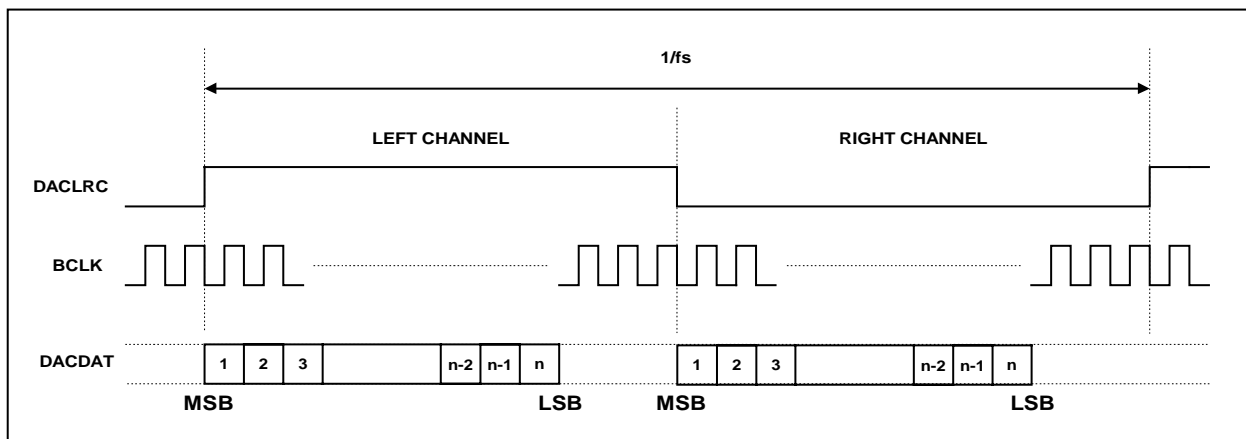

Figure 13 Left Justified Mode

I2S mode is where the MSB is available on the 2nd rising edge of BCLK following a LRCLK transition.

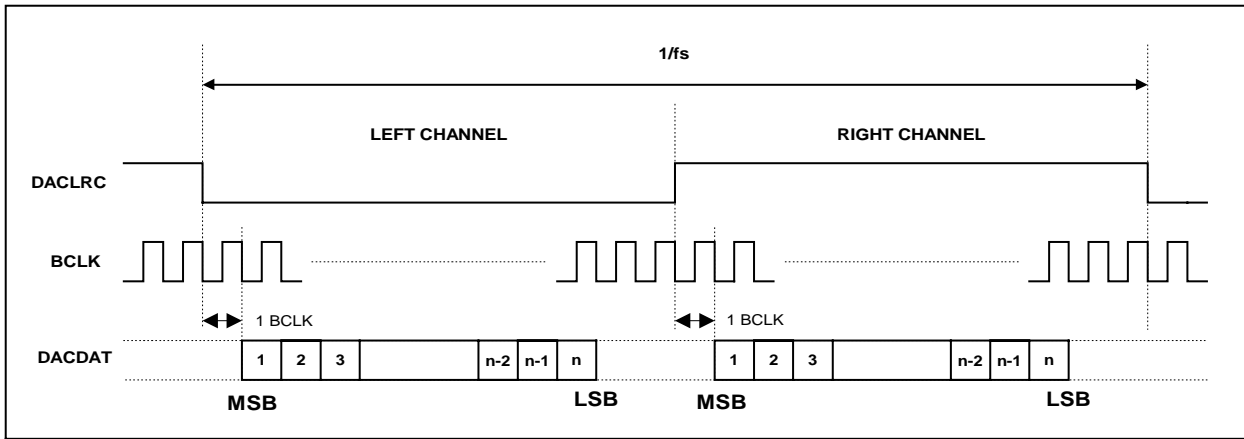

Figure 14 I2S Mode

Right Justified mode is where the LSB is available on the rising edge of BCLK preceding a LRCLK transition, yet MSB is still transmitted first.

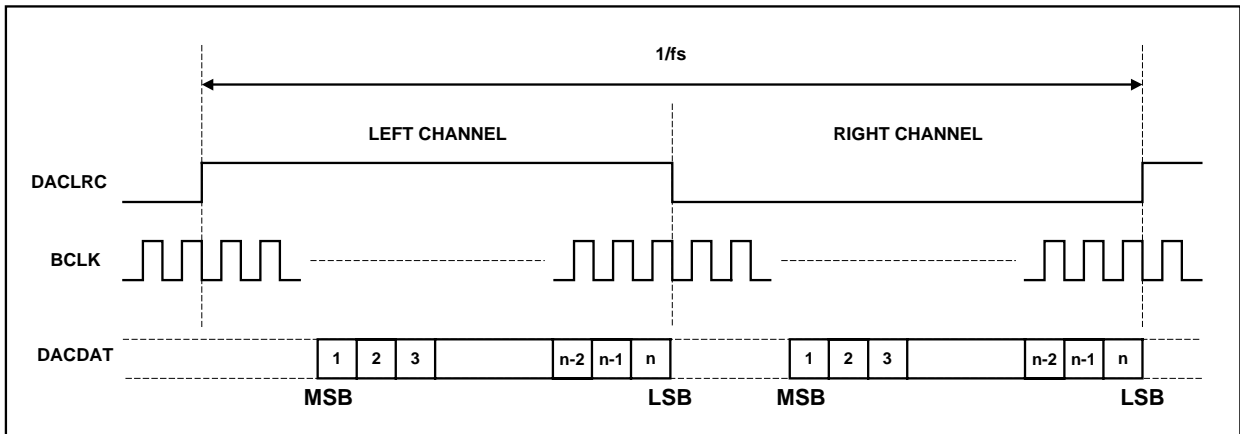

Figure 15 Right Justified Mode

DSP mode is where the left channel MSB is available on either the 1st or 2nd rising edge of BCLK (selectable by LRP) following an LRCLK transition high. Right channel data immediately follows left channel data.

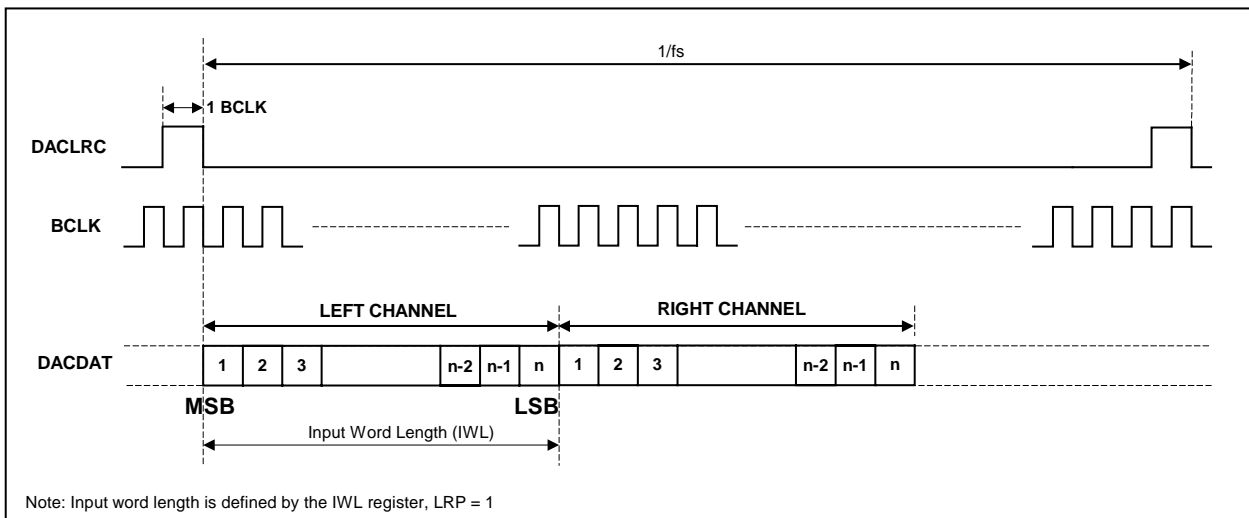

Figure 16 DSP Mode

In all modes DACLRC must always change on the falling edge of BCLK, refer to Figure 13, Figure 14, Figure 15 and Figure 16. Operating the digital audio interface in DSP mode allows ease of use for supporting the various sample rates and word lengths. The only requirement is that all data is transferred within the correct number of BCLK cycles to suit the chosen word length.

In order for the digital audio interface to offer similar support in the three other modes (Left Justified, I2S and Right Justified), the DACLRC and BCLK frequencies, continuity and mark-space ratios need more careful consideration.

In Slave mode, DACLRC inputs are not required to have a 50:50 mark-space ratio. BCLK input need not be continuous. It is however required that there are sufficient BCLK cycles for each DACLRC transition to clock the chosen data word length. The non-50:50 requirement on the LRC is of use in some situations such as with a USB 12MHz clock. Here simply dividing down a 12MHz clock within the DSP to generate LRC and BCLK will not generate the appropriate DACLRC since it will no longer change on the falling edge of BCLK. For example, with 12MHz/32k fs mode there are 375 MCLK per LRC. In these situations DACLRC can be made non 50:50.

In Master mode, DACLRC will be output with a 50:50 mark-space ratio with BCLK output at 64fs. The exception is in 96/88.2k mode where BCLK is MCLK and in USB mode where BCLK is always 12MHz. So for example in 12MHz/32k fs mode there are 375 master clocks per LRC period. Therefore the DACLRC output will have a mark space ratio of 187:188.

The DAC digital audio interface modes are software configurable as indicated in Table 8. Note that dynamically changing the software format may result in erroneous operation of the interfaces and is therefore not recommended.

The length of the digital audio data is programmable at 16/20/24 or 32 bits. Refer to the software control table below. The data is signed 2's complement. The DAC digital filters process data using 24 bits. If the DAC is programmed to receive 16 or 20 bit data, the WM8711 packs the LSBs with zeros. If the DAC is programmed to receive 32 bit data, then it strips the LSBs.

The DAC outputs can be swapped under software control using LRP and LRSWAP as shown in Table 8. Stereo samples are normally generated as a Left/Right sampled pair. LRSWAP reverses the order of that a Left sample goes to the right DAC output and a Right sample goes to the left DAC output. LRP swaps the phasing so that a Right/Left sampled pair is expected and preserves the correct channel phase difference, except in DSP mode, where LRP controls the positioning of the MSB relative to the rising edge of DACLRC.

To accommodate system timing requirements the interpretation of BCLK maybe inverted, this is controlled via the software shown in Table 8. This is especially appropriate for DSP mode.

REGISTER ADDRESS	BIT	LABEL	DEFAULT	DESCRIPTION
0000111 Digital Audio Interface Format	1:0	FORMAT[1:0]	10	Audio Data Format Select 11 = DSP Mode, frame sync + 2 data packed words 10 = I ² S Format, MSB-First left-1 justified 01 = MSB-First, left justified 00 = MSB-First, right justified
	3:2	IWL[1:0]	10	Input Audio Data Bit Length Select 11 = 32 bits 10 = 24 bits 01 = 20 bits 00 = 16 bits
	4	LRP	0	DACLRC phase control (in left, right or I ² S modes) 1 = Right Channel DAC data when DACLRC high 0 = Right Channel DAC data when DACLRC low (opposite phasing in I ² S mode) <i>or</i> DSP mode A/B select (in DSP mode only) 1 = MSB is available on 2 nd BCLK rising edge after DACLRC rising edge 0 = MSB is available on 1st BCLK rising edge after DACLRC rising edge
	5	LRSWAP	0	DAC Left Right Clock Swap 1 = Right Channel DAC Data Left 0 = Right Channel DAC Data Right
	6	MS	0	Master Slave Mode Control 1 = Enable Master Mode 0 = Enable Slave Mode
	7	BCLKINV	0	Bit Clock Invert 1 = Invert BCLK 0 = Don't invert BCLK

Table 8 Digital Audio Interface Control

Note: If right justified 32 bit mode is selected then the WM8711 defaults to 24 bits.

MASTER AND SLAVE MODE OPERATION

The WM8711 can be configured as either a master or slave mode device. As a master mode device the WM8711 controls sequencing of the data and clocks on the digital audio interface. As a slave device the WM8711 responds with data to the clocks it receives over the digital audio interface. The mode is set with the MS bit of the control register as shown in Table 9.

REGISTER ADDRESS	BIT	LABEL	DEFAULT	DESCRIPTION
0000111 Digital Audio Interface Format	6	MS	0	Master Slave Mode Control 1 = Enable Master Mode 0 = Enable Slave Mode

Table 9 Programming Master/Slave Modes

As a master mode device the WM8711 controls the sequencing of data transfer (DACDAT) and output of clocks (BCLK, DACLRC) over the digital audio interface. It uses the timing generated from the MCLK input as the reference for the clock and data transitions. This is illustrated in Figure 17. DACDAT is always an input to the WM8711 independent of master or slave mode.

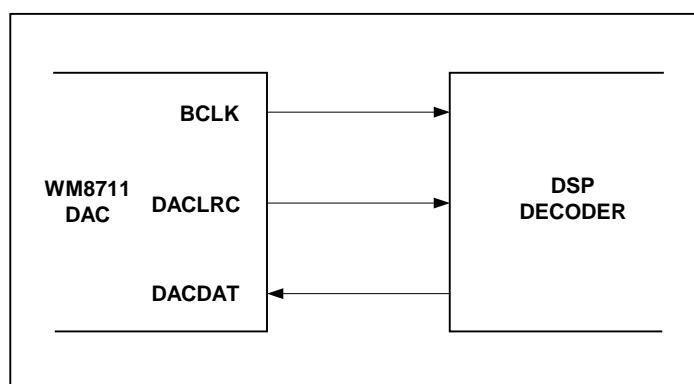

Figure 17 Master Mode

As a slave device the WM8711 sequences the data transfer (DACDAT) over the digital audio interface in response to the external applied clocks (BCLK, DACLRC). This is illustrated in Figure 18.

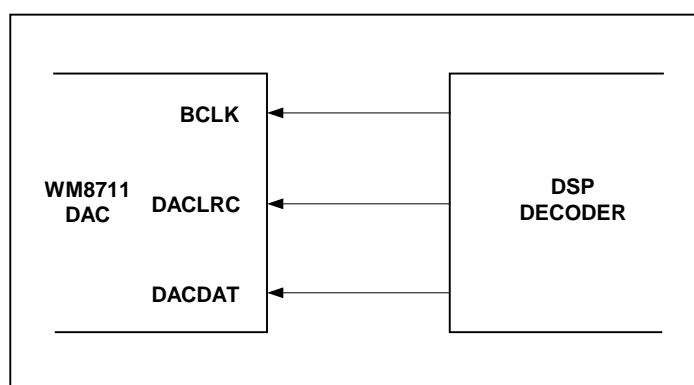

Figure 18 Slave Mode

Note that the WM8711 relies on controlled phase relationships between audio interface BCLK, DACLRC and the master MCLK or CLKOUT. To avoid any timing hazards, refer to the timing section for detailed information.

AUDIO DATA SAMPLING RATES

The WM8711 provides for two modes of operation (normal and USB) to generate the required DAC sampling rates. Normal and USB modes are programmed under software control according to the table below.

In Normal mode, the user controls the sample rate by using an appropriate MCLK frequency and the sample rate control register setting. The WM8711 can support sample rates from 8ks/s up to 96ks/s.

In USB mode, the user must use a fixed MCLK frequency of 12MHz to generate sample rates from 8ks/s to 96ks/s. It is called USB mode since the common USB (Universal Serial Bus) clock is at 12MHz and the WM8711 can be directly used within such systems. WM8711 can generate all the normal audio sample rates from this one Master Clock frequency, removing the need for different master clocks or PLL circuits.

REGISTER ADDRESS	BIT	LABEL	DEFAULT	DESCRIPTION
0001000 Sampling Control	0	USB/ NORMAL	0	Mode Select 1 = USB mode (250/272fs) 0 = Normal mode (256/384fs)
	1	BOSR	0	Base Over-Sampling Rate USB Mode 0 = 250fs 1 = 272fs Normal Mode 0 = 256fs 1 = 384fs
	5:2	SR[3:0]	0000	DAC sample rate control; See USB Mode and Normal Mode Sample Rate sections for operation

Table 10 Sample Rate Control

NORMAL MODE SAMPLE RATES

In normal mode MCLK is set up according to the desired sample rates of the DAC. For DAC sampling rates of 8, 32, 48 or 96KHz, MCLK frequencies of either 12.288MHz (256Fs) or 18.432MHz (384Fs) can be used. DAC sampling rates of 8, 44.1 or 88.2KHz from MCLK frequencies of either 11.2896MHz (256Fs) or 16.9344MHz (384Fs) can be used.

The table below should be used to set up the device to work with the various sample rate combinations. Refer to Digital Filter Characteristics section for an explanation of the different filter types.

SAMPLING RATE DAC	MCLK FREQUENCY	SAMPLE RATE REGISTER SETTINGS					DIGITAL FILTER TYPE
		BOSR	SR3	SR2	SR1	SR0	
KHz	MHz						
48	12.288	0	0	0	0	0	1
	18.432	1	0	0	0	0	
8	12.288	0	0	0	0	1	1
	18.432	1	0	0	0	1	
32	12.288	0	0	1	1	0	1
	18.432	1	0	1	1	0	
96	12.288	0	0	1	1	1	2
	18.432	1	0	1	1	1	
44.1	11.2896	0	1	0	0	0	1
	16.9344	1	1	0	0	0	
8 (Note 1)	11.2896	0	1	0	0	1	1
	16.9344	1	1	0	0	1	
88.2	11.2896	0	1	1	1	1	2
	16.9344	1	1	1	1	1	

Table 11 Normal Mode Sample Rate Look-up Table

Notes:

- 8k not exact, actual = 8.018kHz
- All other combinations of BOSR and SR[3:0] that are not in the truth table are invalid

The BOSR bit represents the base over-sampling rate. This is the rate that the WM8711 digital signal processing is carried out at. In Normal mode, with BOSR = 0, the base over-sampling rate is at 256Fs, with BOSR = 1, the base over-sampling rate is at 384Fs. This can be used to determine the actual audio data rate required by the DAC.

The exact sample rates achieved are defined by the relationships in Table 12 below.

TARGET SAMPLING RATE	ACTUAL SAMPLING RATE			
	BOSR=0 (256FS)		BOSR=1 (384FS)	
	MCLK=12.288	MCLK=11.2896	MCLK=18.432	MCLK=16.9344
KHz	KHz	KHz	KHz	KHz
8	8	8.018	8	8.018
	12.288MHz/256 x 1/6	11.2896MHz/256 x 2/11	18.432MHz/384 x 1/6	16.9344MHz/384 x 2/11
32	32	<i>not available</i>	32	<i>not available</i>
	12.288MHz/256 x 2/3		18.432MHz/384x 2/3	
44.1	<i>not available</i>	44.1	<i>not available</i>	44.1
		11.2896MHz/256		16.9344MHz /384
48	48	<i>not available</i>	48	<i>not available</i>
	12.288MHz/256		18.432MHz/384	
88.2	<i>not available</i>	88.2	<i>not available</i>	88.2
		11.2896MHz/384 x 2		16.9344MHz /384 x 2
96	96	<i>not available</i>	96	<i>not available</i>
	12.288MHz/256 x 2		18.432MHz/384 x 2	

Table 12 Normal Mode Actual Sample Rates

128/192FS NORMAL MODE

The Normal Mode sample rates are designed for standard 256Fs and 384Fs MCLK rates. However the WM8711 is also capable of being clocked from a 128/192Fs MCLK for application over limited sampling rates as shown in the table below.

SAMPLING RATE		MCLK FREQUENCY	SAMPLE RATE REGISTER SETTINGS					DIGITAL FILTER TYPE
ADC	DAC		BOSR	SR3	SR2	SR1	SR0	
KHz	KHz	MHz						
48	48	6.144	0	0	1	1	1	2
		9.216	1	0	1	1	1	
44.1	44.1	5.6448	0	1	1	1	1	2
		8.4672	1	1	1	1	1	

Table 13 128/192Fs Normal Mode Sample Rate Look-up Table

512/768FS NORMAL MODE

512 Fs and 768 Fs MCLK rates can be accommodated by using the CLKIDIV2 bit. The core clock to the DSP will be divided by 2 so an external 512/768 MCLK will become 256/384 Fs internally and the device otherwise operates as in Table 10 but with MCLK at twice the specified rate.

USB MODE SAMPLE RATES

In USB mode the MCLK input is 12MHz only.

SAMPLING RATE DAC	MCLK FREQUENCY	SAMPLE RATE REGISTER SETTINGS					DIGITAL FILTER TYPE
		BOSR	SR3	SR2	SR1	SR0	
KHz	MHz						
48	12.000	0	0	0	0	0	0
44.1 (Note 2)	12.000	1	1	0	0	0	1
8	12.000	0	0	0	0	1	0
8 (Note 1)	12.000	1	1	0	0	1	1
32	12.000	0	0	1	1	0	0
96	12.000	0	0	1	1	1	3
88.2 (Note 3)	12.000	1	1	1	1	1	2

Table 14 USB Mode Sample Rate Look-Up Table

Notes:

- 8k not exact, actual = 8.021kHz
- 44.1k not exact, actual = 44.118kHz
- 88.1k not exact, actual = 88.235kHz
- All other combinations of BOSR and SR[3:0] that are not in the truth table are invalid

The BOSR bit represents the base over-sampling rate. This is the rate that the WM8711 digital signal processing is carried out at and the sampling rate will always be a sub-multiple of this. In USB mode, with BOSR = 0, the base over-sampling rate is defined at 250Fs, with BOSR = 1, the base over-sampling rate is defined at 272Fs. This can be used to determine the actual audio sampling rate required by the DAC.

The exact sample rates supported for all combinations are defined by the relationships in Table 15 below.

TARGET SAMPLING RATE	ACTUAL SAMPLING RATE	
	BOSR=0 (250FS)	BOSR=1 (272FS)
KHz	KHz	KHz
8	8	8.021
	$12\text{MHz}/(250 \times 48/8)$	$12\text{MHz}/(272 \times 11/2)$
32	32	<i>not available</i>
	$12\text{MHz}/(250 \times 48/32)$	
44.1	<i>not available</i>	44.117
		$12\text{MHz}/272$
48	48	<i>not available</i>
	$12\text{MHz}/250$	
88.2	<i>not available</i>	88.235
		$12\text{MHz}/136$
96	96	<i>not available</i>
	$12\text{MHz}/125$	

Table 15 USB Mode Actual Sample Rates

ACTIVATING DSP AND DIGITAL AUDIO INTERFACE

To prevent any communication problems from arising across the Digital Audio Interface is disabled (tristate with weak 100k pulldown) at power on. Once the Audio Interface and the Sampling Control has been programmed it is activated by setting the ACTIVE bit under Software Control.

REGISTER ADDRESS	BIT	LABEL	DEFAULT	DESCRIPTION
0001001 Active Control	0	ACTIVE	0	Activate Interface 1 = Active 0 = Inactive

Table 16 Activating DSP and Digital Audio Interface

It is recommended that between changing any content of Digital Audio Interface or Sampling Control Register that the active bit is reset then set.

SOFTWARE CONTROL INTERFACE

The software control interface may be operated using either a 3-wire or 2-wire MPU interface. Selection of interface format is achieved by setting the state of the MODE pin.

In 3-wire mode, SDIN is used for the program data, SCLK is used to clock in the program data and CSB is used to latch in the program data. In 2-wire mode, SDIN is used for serial data and SCLK is used for the serial clock. In 2-wire mode, the state of CSB pin allows the user to select one of two addresses.

SELECTION OF SERIAL CONTROL MODE

The serial control interface may be selected to operate in either 2 or 3-wire modes. This is achieved by setting the state of the MODE pin.

MODE	INTERFACE FORMAT
0	2 wire
1	3 wire

Table 17 Control Interface Mode Selection

3-WIRE (SPI COMPATIBLE) SERIAL CONTROL MODE

The WM8711 can be controlled using a 3-wire serial interface. SDIN is used for the program data, SCLK is used to clock in the program data and CSB is use to latch in the program data. The 3-wire interface protocol is shown in Figure 19.

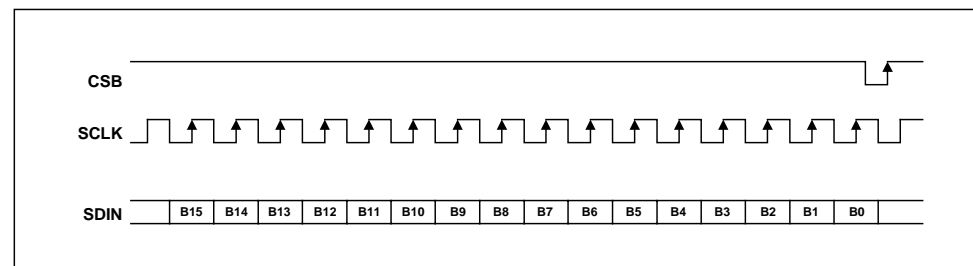

Figure 19 3-Wire Serial Interface

Notes:

1. B[15:9] are Control Address Bits
2. B[8:0] are Control Data Bits

2-WIRE SERIAL CONTROL MODE

The WM8711 supports a 2-wire MPU serial interface. The device operates as a slave device only. The WM8711 has one of two slave addresses that are selected by setting the state of pin 10, (CSB).

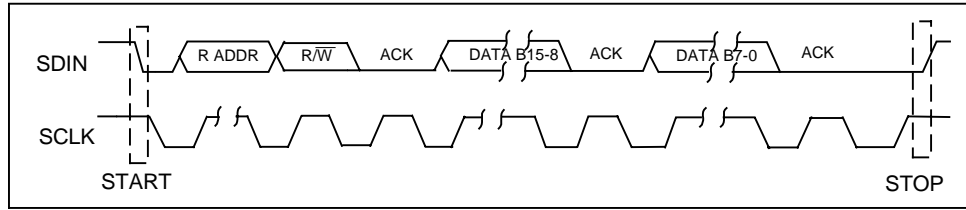

Figure 20 2-Wire Serial Interface

Notes:

1. B[15:9] are Control Address Bits
2. B[8:0] are Control Data Bits

CSB STATE (DEFAULT = LOW)	ADDRESS
0	0011010
1	0011011

Table 18 2-Wire MPU Interface Address Selection

To control the WM8711 on the 2-wire bus the master control device must initiate a data transfer by establishing a start condition, defined by a high to low transition on SDIN while SCLK remains high. This indicates that an address and data transfer will follow. All peripherals on the 2-wire bus respond to the start condition and shift in the next eight bits (7-bit address + R/W bit). The transfer is MSB first. The 7-bit address consists of a 6-bit base address + a single programmable bit to select one of two available addresses for this device (see Table 18). If the correct address is received and the R/W bit is '0', indicating a write, then the WM8711 will respond by pulling SDIN low on the next clock pulse (ACK). The WM8711 is a write only device and will only respond to the R/W bit indicating a write. If the address is not recognised the device will return to the idle condition and wait for a new start condition and valid address.

Once the WM8711 has acknowledged a correct address, the controller will send eight data bits (bits B[15]-B[8]). WM8711 will then acknowledge the sent data by pulling SDIN low for one clock pulse. The controller will then send the remaining eight data bits (bits B[7]-B[0]) and the WM8711 will then acknowledge again by pulling SDIN low.

A stop condition is defined when there is a low to high transition on SDIN while SCLK is high. If a start or stop condition is detected out of sequence at any point in the data transfer then the device will jump to the idle condition.

After receiving a complete address and data sequence the WM8711 returns to the idle state and waits for another start condition. Each write to a register requires the complete sequence of start condition, device address and R/W bit followed by the 16 register address and data bits.

POWER DOWN MODES

The WM8711 contains power conservation modes in which various circuit blocks may be safely powered down in order to conserve power. This is software programmable as shown in the table below.

REGISTER ADDRESS	BIT	LABEL	DEFAULT	DESCRIPTION
0000110 Power Down Control	0	LINEINPD	1	Line Input Power Down 1 = Enable Power Down 0 = Disable Power Down
	3	DACPD	1	DAC Power Down 1 = Enable Power Down 0 = Disable Power Down
	4	OUTPD	1	Line Output Power Down 1 = Enable Power Down 0 = Disable Power Down
	5	OSCPD	0	Oscillator Power Down 1 = Enable Power Down 0 = Disable Power Down
	6	CLKOUTPD	0	CLKOUT Power Down 1 = Enable Power Down 0 = Disable Power Down
	7	POWEROFF	1	Power Off Device 1 = Device Power Off 0 = Device Power On

Table 19 Power Conservation Modes Software Control

Note:

- When writing to register 0000110 bits 1 and 2 should be set to 1.

The power down control can be used to either a) permanently disable functions when not required in certain applications or b) to dynamically power up and down functions depending on the operating mode, e.g.: during playback or record. Please follow the special instructions below if dynamic implementations are being used.

DACPD: Powers down the DAC and DAC Digital Filters. If this is done dynamically then audible pops will result unless the following guidelines are followed. In order to prevent pops, the DAC should first be soft-muted (DACMU), the output should then be de-selected from the line and headphone output (DACSEL), then the DAC powered down (DACPD). This is of use when the device enters Pause or Stop modes. During DACPD the digital audio interface is remains active.

OUTPD: Powers down the Line Headphone Output. If this is done dynamically then audible pops may result unless the DAC is first soft-muted (DACMU). This is of use when the device enters Record, Pause or Stop modes.

The device can be put into a standby mode (STANDBY) by powering down all the audio circuitry under software control as shown in Table 20.

POWER OFF	CLKOUTPD	OSCPD	OUTPD	DACPD	LINEINPD	DESCRIPTION
0	0	0	1	1	1	STANDBY, but with Crystal Oscillator OS and CLKOUT available
0	1	0	1	1	1	STANDBY, but with Crystal Oscillator OS available, CLKOUT not-available
0	1	1	1	1	1	STANDBY, Crystal oscillator and CLKOUT not-available.

Table 20 Standby Mode

In STANDBY mode the Control Interface, a small portion of the digital and areas of the analogue circuitry remain active. The active analogue includes the analogue VMID reference so that the analogue line outputs and headphone outputs remain biased to VMID. This reduces any audible effects caused by DC glitches when entering or leaving STANDBY mode.

The device can be powered off by writing to the POWEROFF bit of the Power Down register. In POWEROFF mode the Control Interface and a small portion of the digital remain active. The analogue VMID reference is disabled. Refer to Table 21.

POWER OFF	CLKOUTPD	OSCPD	OUTPD	DACPD	LINEINPD	DESCRIPTION
1	0	0	X	1	1	POWEROFF, but with Crystal Oscillator OS and CLKOUT available
1	1	0	X	1	1	POWEROFF, but with Crystal Oscillator OS available, CLKOUT not-available
1	1	1	X	1	X	POWEROFF, Crystal oscillator and CLKOUT not-available.

Table 21 Poweroff Mode

REGISTER MAP

The complete register map is shown in Table 22. The detailed description can be found in the relevant text of the device description. There are 8 registers with 9 bits per register. These can be controlled using either the 2 wire or 3 wire MPU interface.

REGISTER ADDRESS	BIT	LABEL	DEFAULT	DESCRIPTION
0000010 Left Headphone Out	6:0	LHPVOL [6:0]	1111001 (0dB)	Left Channel Headphone Output Volume Control 1111111 = +6dB .. 1dB steps down to 0110000 = -73dB 0000000 to 0101111 = MUTE
	7	LZCEN	1	Left Channel Zero Cross detect Enable 1 = Enable 0 = Disable
	8	LRHPBOTH	0	Left to Right Channel Headphone Volume, Mute and Zero Cross Data Load Control 1 = Enable Simultaneous Load of LHPVOL[6:0] and LZCEN to RHPVOL[6:0] and RZCEN 0 = Disable Simultaneous Load

REGISTER ADDRESS	BIT	LABEL	DEFAULT	DESCRIPTION
0000011 Right Headphone Out	6:0	RHPVOL [6:0]	1111001 (0dB)	Right Channel Headphone Output Volume Control 1111111 = +6dB ... 1dB steps down to 0110000 = -73dB 0000000 to 0101111 = MUTE
	7	RZCEN	1	Right Channel Zero Cross detect Enable 1 = Enable 0 = Disable
	8	RLHPBOTH	0	Right to Left Channel Headphone Volume, Mute and Zero Cross Data Load Control 1 = Enable Simultaneous Load of RHPVOL[6:0] and RZCEN to LHPVOL[6:0] and LZCEN 0 = Disable Simultaneous Load
0000100 Audio Path Control	3	BYPASS	1	Bypass Switch 1 = Enable Bypass 0 = Disable Bypass
	4	DACSEL	0	DAC Select (Analogue) 1 = Select DAC 0 = Don't select DAC
0000101 Digital Audio Path Control	2:1	DEEMP[1:0]	00	De-emphasis Control (Digital) 11 = 48KHz 10 = 44.1KHz 01 = 32KHz 00 = Disable
	3	DACMU	1	DAC Soft Mute Control (Digital) 1 = Enable soft mute 0 = Disable soft mute
0000110 Power Down Control	0	LINEINPD	1	Line Input Power Down 1 = Enable Power Down 0 = Disable Power Down
	3	DACPD	1	DAC Power Down 1 = Enable Power Down 0 = Disable Power Down
	4	OUTPD	1	Outputs Power Down 1 = Enable Power Down 0 = Disable Power Down
	5	OSCPD	0	Oscillator Power Down 1 = Enable Power Down 0 = Disable Power Down
	6	CLKOUTPD	0	CLKOUT Power Down 1 = Enable Power Down 0 = Disable Power Down
	7	POWEROFF	1	POWEROFF mode 1 = Enable POWEROFF 0 = Disable POWEROFF

REGISTER ADDRESS	BIT	LABEL	DEFAULT	DESCRIPTION
0000111 Digital Audio Interface Format	1:0	FORMAT[1:0]	10	Audio Data Format Select 11 = DSP Mode, frame sync + 2 data packed words 10 = I2S Format, MSB-First left-1 justified 01 = MSB-First, left justified 00 = MSB-First, right justified
	3:2	IWL[1:0]	10	Input Audio Data Bit Length Select 11 = 32 bits 10 = 24 bits 01 = 20 bits 00 = 16 bits
	4	LRP	0	DACLRC phase control (in left, right or I ² S modes) 1 = Right Channel DAC data when DACLRC high 0 = Right Channel DAC data when DACLRC low (opposite phasing in I ² S mode) <i>or</i> DSP mode A/B select (in DSP mode only) 1 = MSB is available on 2 nd BCLK rising edge after DACLRC rising edge 0 = MSB is available on 1st BCLK rising edge after DACLRC rising edge
	5	LRSWAP	0	DAC Left Right Clock Swap 1 = Right Channel DAC Data Left 0 = Right Channel DAC Data Right
	6	MS	0	Master Slave Mode Control 1 = Enable Master Mode 0 = Enable Slave Mode
	7	BCLKINV	0	Bit Clock Invert 1 = Invert BCLK 0 = Don't invert BCLK
	0001000 Sampling Control	0	USB/ NORMAL	0
1		BOSR	0	Base Over-Sampling Rate
				USB Mode 0 = 250fs 1 = 272fs
5:2		SR[3:0]	0000	DAC sample rate control; See USB Mode and Normal Mode Sample Rate sections for operation
6		CLKIDIV2	0	Core Clock divider select 1 = Core Clock is MCLK divide by 2 0 = Core Clock is MCLK
7	CLKODIV2	0	CLKOUT divider select 1 = CLOCKOUT is MCLK divide by 2 0 = CLOCKOUT is MCLK	

REGISTER ADDRESS	BIT	LABEL	DEFAULT	DESCRIPTION
0001001 Active Control	0	ACTIVE	0	Activate Interface 1 = Active 0 = Inactive
0001111 Reset Register	8:0	RESET	not reset	Reset Register Writing 00000000 to register resets device
1110000 Test Failsafe	0	TESTFAIL SAFE	0	Test Mode Failsafe Bit 1 = Test Mode Allowed 0 = Test Mode Locked Out
1110001 Analogue Test Register 1	8:0	AATEST1[8:0]	0	Analogue Test Register 1
1110010 Analogue Test Register 2	8:0	AATEST2[8:0]	0	Analogue Test Register 2
1110011 Digital Test Register 1	8:0	DTEST1[8:0]	0	Digital Test Register 1
11100100 Digital Test Register 2	8:0	DTEST2[8:0]	0	Digital Test Register 2

Table 22 Register Map Description

Note:

All other bits not explicitly defined in the register table should be set to zero unless specified otherwise (see powerdown section).

DIGITAL FILTER CHARACTERISTICS

The DAC employ different digital filters. There are 4 types of digital filter, called Type 0, 1, 2 and 3. The performance of Types 0 and 1 is listed in the table below, the responses of all filters is shown in the proceeding pages.

PARAMETER	TEST CONDITIONS	MIN	TYP	MAX	UNIT
DAC Filter Type 0 (USB mode, 250fs operation)					
Passband	+/- 0.03dB	0		0.416fs	
	-6dB		0.5fs		
Passband Ripple				+/-0.03	dB
Stopband		0.584fs			
Stopband Attenuation	f > 0.584fs	-50			dB
DAC Filter Type 1 (USB mode, 272fs or Normal mode operation)					
Passband	+/- 0.03dB	0		0.4535fs	
	-6dB		0.5fs		
Passband Ripple				+/- 0.03	dB
Stopband		0.5465fs			
Stopband Attenuation	f > 0.5465fs	-50			dB

Table 23 Digital Filter Characteristics

DAC FILTER RESPONSES

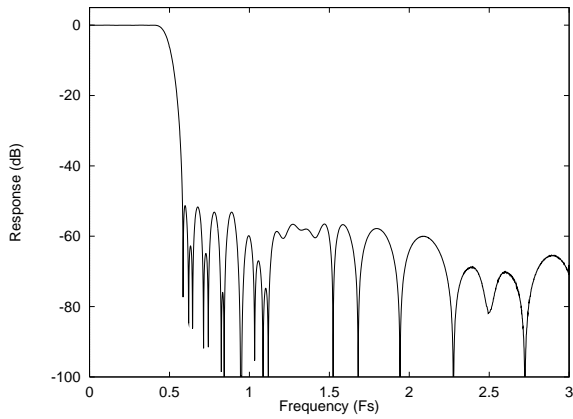

Figure 21 DAC Digital Filter Frequency Response-Type 0

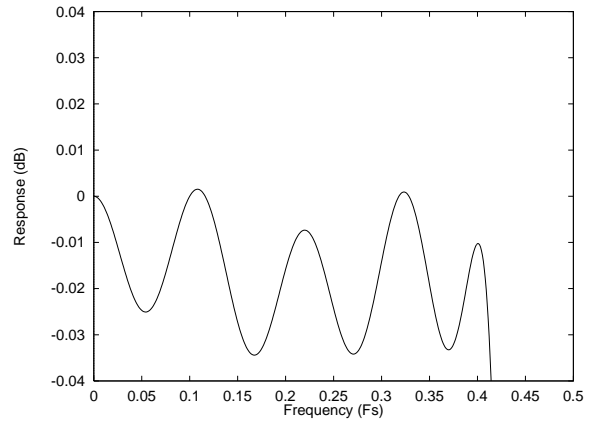

Figure 22 DAC Digital Filter Ripple-Type 0

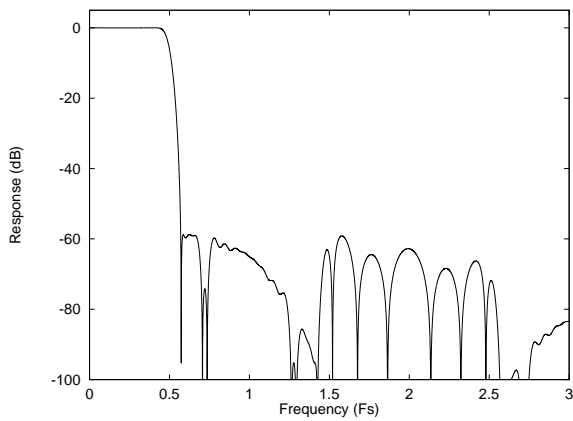

Figure 23 DAC Digital Filter Frequency Response-Type 1

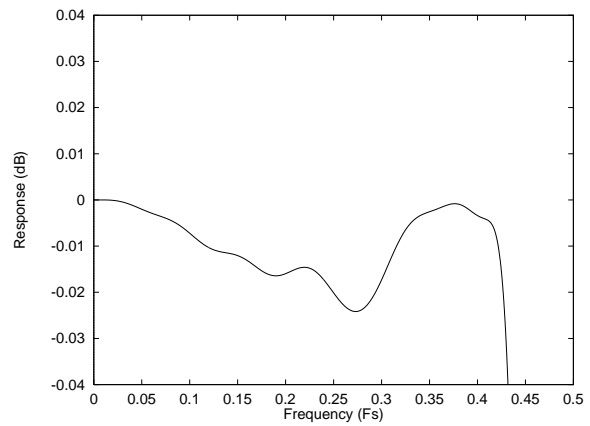

Figure 24 DAC Digital Filter Ripple-Type 1

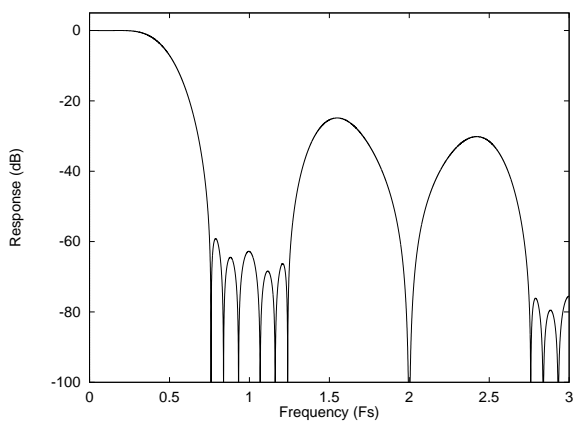

Figure 25 DAC Digital Filter Frequency Response-Type 2

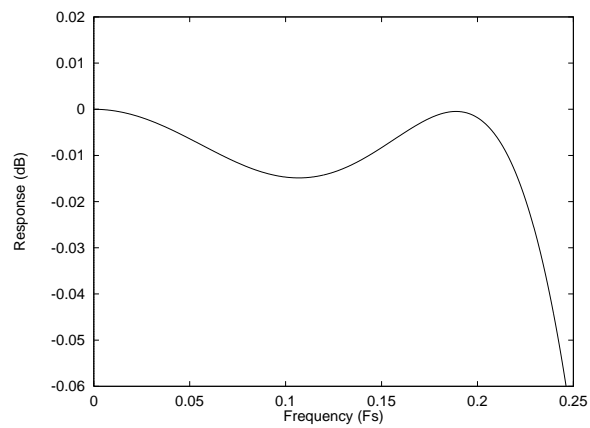

Figure 26 DAC Digital Filter Ripple-Type 2

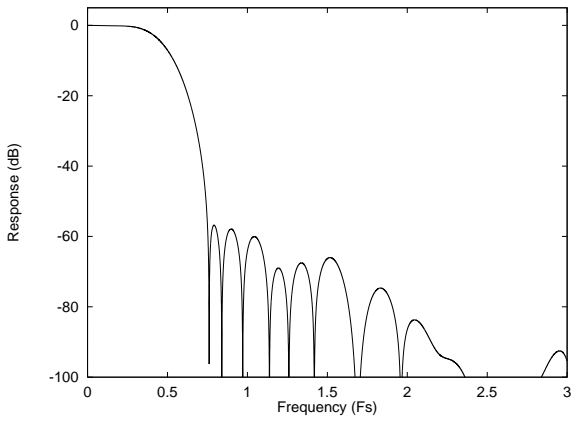

Figure 27 DAC Digital Filter Frequency Response–Type 3

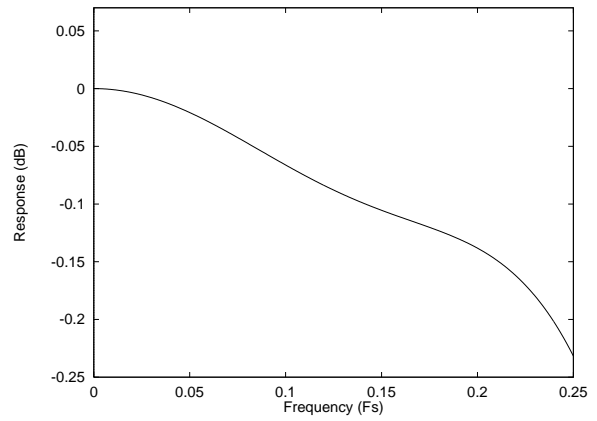

Figure 28 DAC Digital Filter Ripple–Type 3

DIGITAL DE-EMPHASIS CHARACTERISTICS

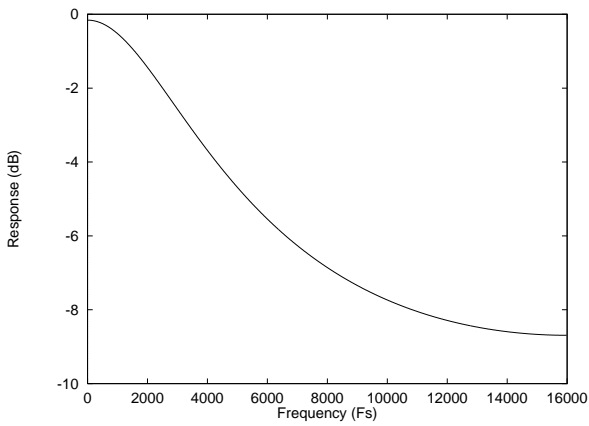

Figure 29 De-Emphasis Frequency Response (32kHz)

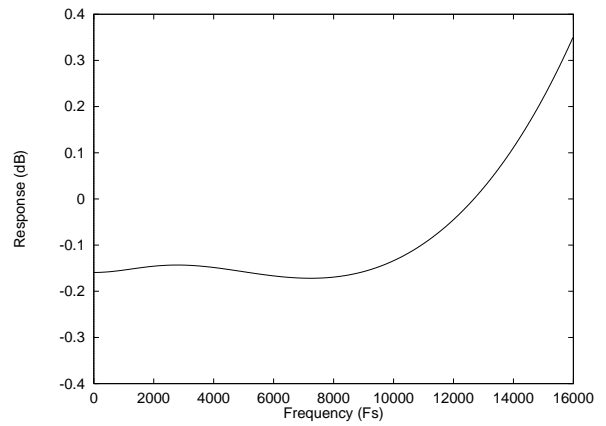

Figure 30 De-Emphasis Error (32kHz)

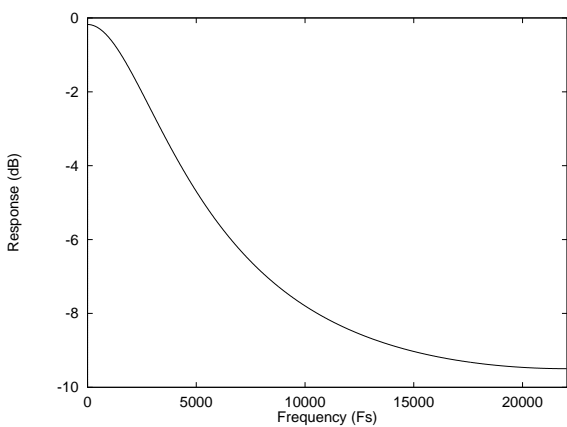

Figure 31 De-Emphasis Frequency Response (44.1kHz)

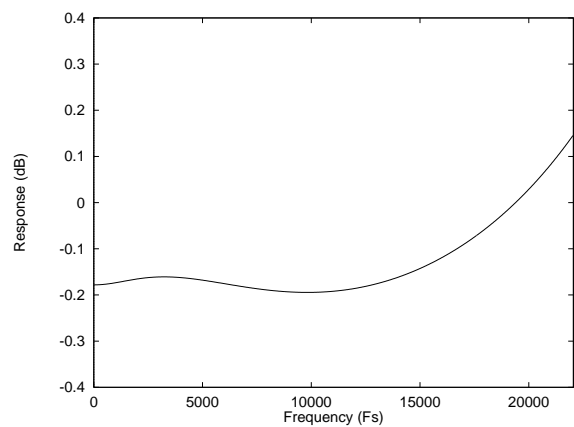

Figure 32 De-Emphasis Error (44.1kHz)

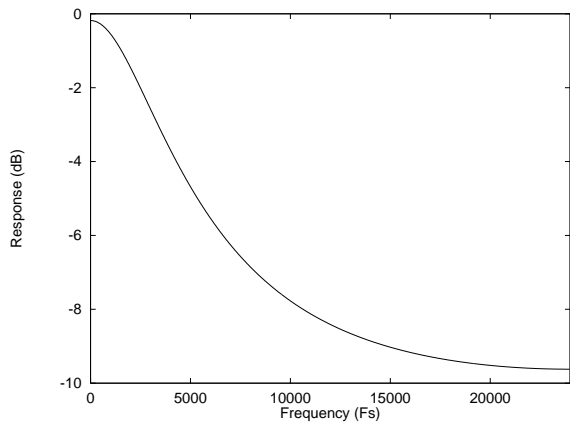

Figure 33 De-Emphasis Frequency Response (48kHz)

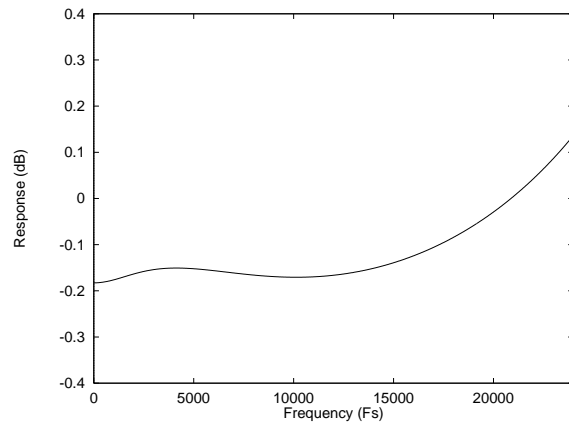

Figure 34 De-Emphasis Error (48kHz)

RECOMMENDED EXTERNAL COMPONENTS

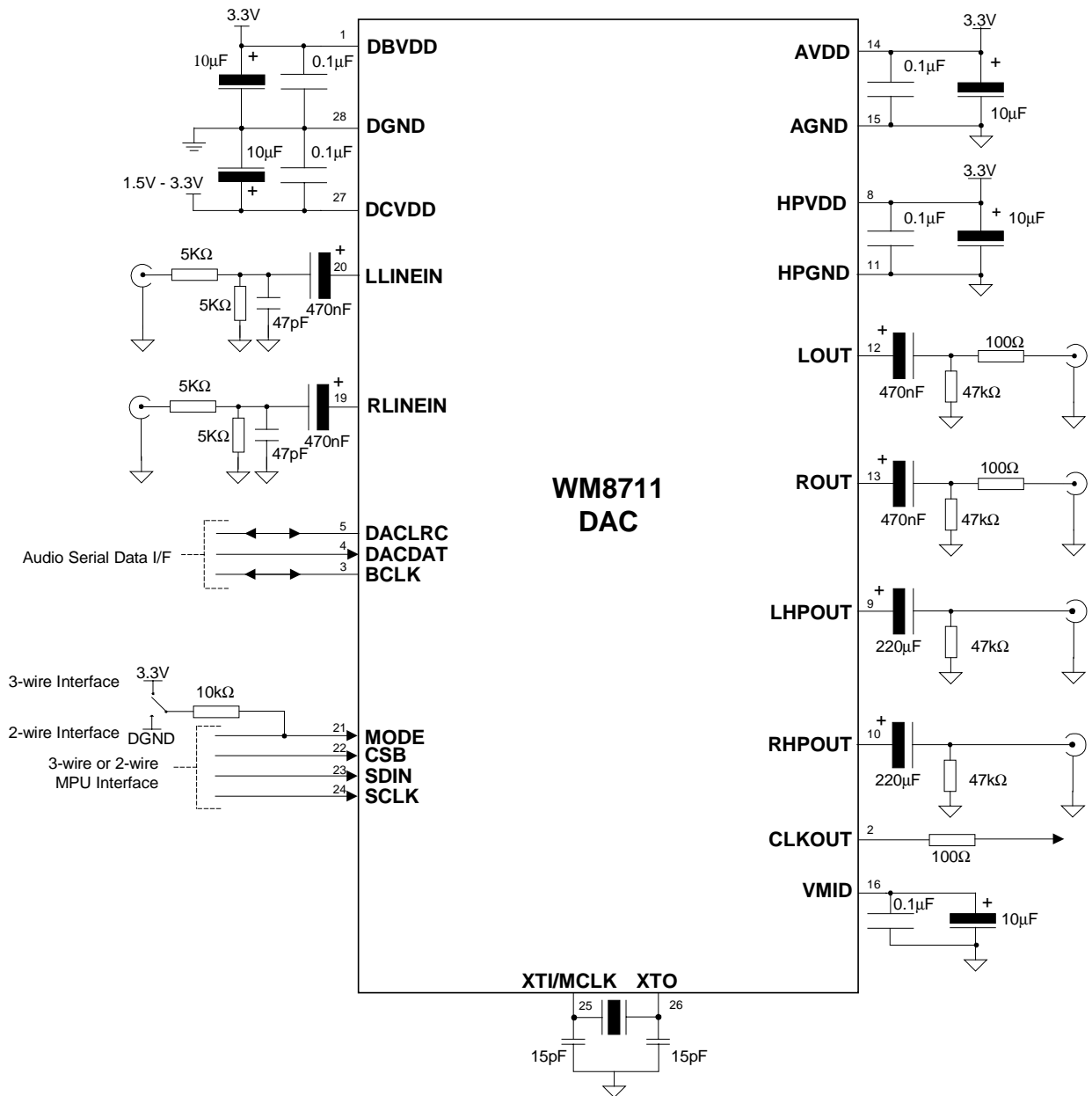
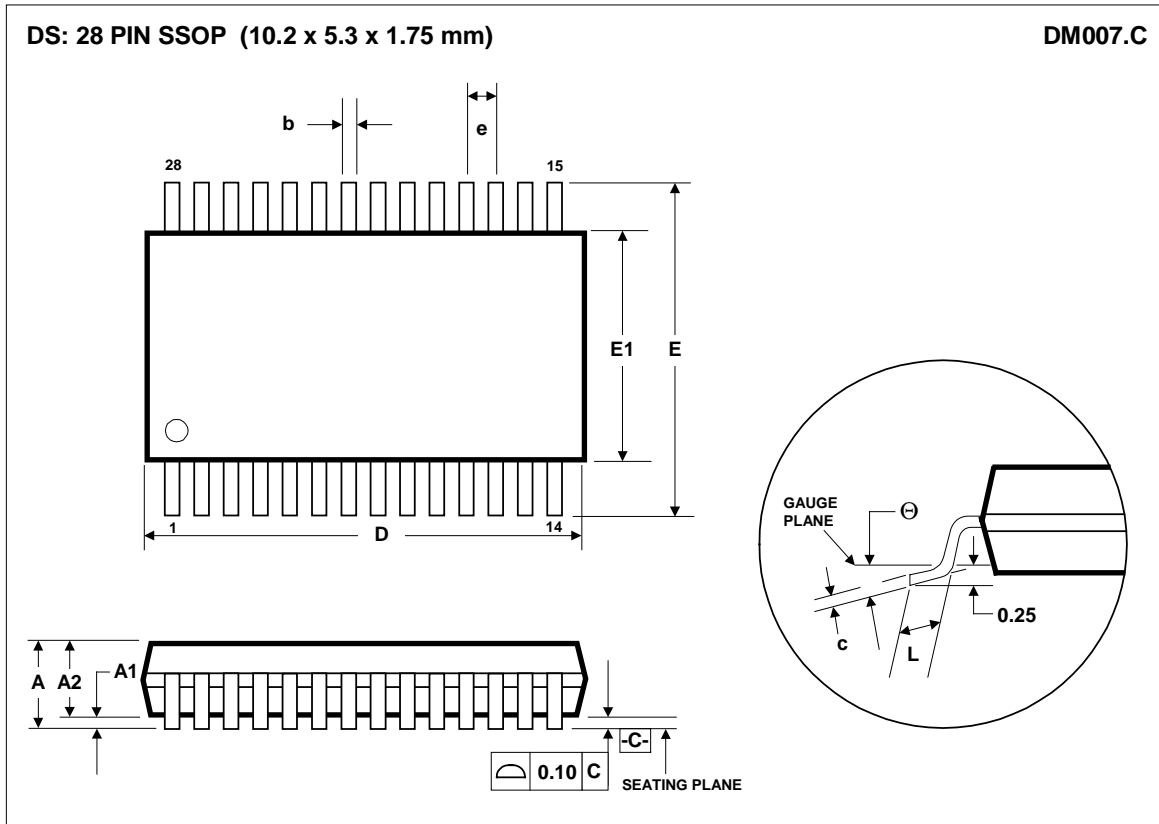

Figure 35 External Components Diagram

PACKAGE DIMENSIONS



Symbols	Dimensions (mm)		
	MIN	NOM	MAX
A	-----	-----	2.0
A ₁	0.05	-----	-----
A ₂	1.62	1.75	1.85
b	0.22	-----	0.38
c	0.09	-----	0.25
D	9.90	10.20	10.50
e	0.65 BSC		
E	7.40	7.80	8.20
E ₁	5.00	5.30	5.60
L	0.55	0.75	0.95
θ	0°	4°	8°
REF:	JEDEC.95, MO-150		

- NOTES:
 A. ALL LINEAR DIMENSIONS ARE IN MILLIMETERS.
 B. THIS DRAWING IS SUBJECT TO CHANGE WITHOUT NOTICE.
 C. BODY DIMENSIONS DO NOT INCLUDE MOLD FLASH OR PROTRUSION, NOT TO EXCEED 0.20MM.
 D. MEETS JEDEC.95 MO-150, VARIATION = AH. REFER TO THIS SPECIFICATION FOR FURTHER DETAILS.